

SERVICE & PARTS MANUAL

Snorkel



M-2032/2639-J
WORK PLATFORM

Local Distributor:

Distributeur local:

El Distribuidor local:

Snorkel International Inc.

P.O. Box 1160

St. Joseph, MO 64502-1160 USA

TEL: + 1-800-255-0317

Snorkel

www.snorkelusa.com

Serial number 501376-101

SERVICE AND PARTS MANUAL

PART NUMBER: 501376-101

SERIAL No. M-2032-J 220 - current

M-2639-J 350 - current

FOREWORD

This manual is divided into six main sections.

SECTION 1 INTRODUCTION

General description, including machine specifications and limitations.

SECTION 2 OPERATION AND SPECIFICATIONS

Information on how to operate the work platform and how to prepare it for operation.

SECTION 3 MAINTENANCE

Preventative maintenance and service information.

SECTION 4 TROUBLESHOOTING

Causes and solutions to typical problems.

SECTION 5 SCHEMATICS

Schematics and valve block diagram with description and location of components.

Large schematic drawings may be located in the pocket at back of the manual.

SECTION 6 ILLUSTRATED PARTS BREAKDOWN

Complete parts lists with illustrations.

Large parts drawings may be located in the back of the manual.

1. Introduction

1.1 INTRODUCTION

PURPOSE & LIMITATIONS

This Service & Parts Manual is designed to provide instructions and illustrations for the safe operation and maintenance of the MB20N & MB26 Work Platform manufactured by Upright Powered Access Ltd. The purpose of this machine is to provide fast and safe access to difficult to reach areas. The machine may only safely operated on firm level ground. Refer to the Specification section for the machines access limitations.

DO NOT use on soft ground or on slopes greater than 2 degrees.

DO NOT use the lifting mechanism to raise or lower goods or persons except within the cage and subject to the weight limitations.

DO NOT enter the platform from a structure, rack or other platform.

SCOPE

This manual includes the procedures and responsibilities for the inspection, transportation, safe operation, maintenance, and repair of this product. The Maintenance Section within the Parts & Service Manual also covers preventative maintenance and troubleshooting.

SPECIAL INFORMATION

Throughout this manual the users attention is drawn to these special warning boxes:

D A N G E R

Indicates an imminently hazardous situation which, if not avoided, will result in severe injury or death.

W A R N I N G

Indicates a potentially hazardous situation which, if not avoided, could result in severe injury or death.

C A U T I O N

Indicates a potentially hazardous situation which, if not avoided, may result in minor or moderate injury.

1.2 GENERAL DESCRIPTION

The MB20/26 are self propelled, fast acting aerial work platforms, designed to raise two operators with hand tools to a platform floor height of 6.00 m and 7.76 m respectively. The accessible height is approximately 2.00 m above these figures. It is designed to travel with safe working load and work tools up to an upper limit of 215 kg (475 lbs). The unit offers the ability to reach over obstacles but must be used on firm and level ground at all times.

PLATFORM

The MB20/26 platform is large enough for two operators and has a free-draining perforated floor with 150 mm toeboards. Hand-rails are constructed from aluminium tubing and a safety drop-bar is provided at the entrance. Safety harness anchor points are also fitted in the floor of the platform. These must be used at all times. The main controls are fitted to this platform.

W A R N I N G

DO NOT use the work platform without guardrails properly assembled and in place.

PLATFORM CONTROLLER

The primary (Upper) control box is permanently fitted to the front of the platform. It features a joystick which provides proportional control for raising or lowering the mast, raising or lowering the jib or rotating the complete mast assembly. The same joystick is also used to drive and steer the machine.

A safety Interlock Switch or 'deadman button' is incorporated into the Joystick. It must be activated at all times in order to operate any function. This feature allows for one-handed operation. A comprehensive explanation of control functions is given in the Operators Manual - a copy of which shall be located in the platform document wallet located just beneath the upper control station in the platform.

The secondary (Lower) control box is fitted to the mast cover at arm level. It features a 'deadman' enable button and selector buttons to provide pre-programmed speeds for all functions except drive and steering. This control station is used primarily for service-type operations including pre-operation inspection. It should never be used to position a manned or unmanned platform. It may be used in the event of emergency, however, to lower the manned platform.

W A R N I N G

NEVER operate the machine from the upper controls until the platform entrance drop-bar is in the fully lowered position and the safety harness is fitted.

ELEVATING ASSEMBLY

The platform is raised and lowered by a combination of a steel jib and a series of telescoping mast sections. The main hydraulic cylinder, mounted within the masts, lifts the first mast directly. The other masts are connected by a system of heavy duty plate chains and pulleys to ensure sequential lifting.

A parallel system of heavy duty straps ensures that the masts descend in the proper sequence and also ensure that a mast cannot be held in suspension by an obstacle during descent.

The jib cylinder provides a lifting arc to the jib and cage assembly. All hydraulic functions are carried out using solenoid operated control valves. Each cylinder features an integral holding valve to prevent uncontrolled descent in the case of a hose bursting.

ROTATION GEAR

The complete mast, jib and cage assembly can be rotated to provide a maximum outreach of 2.6m in the case of the MB20 and 2.96m in the case of the MB26 machine. This dimension is measured from the centreline of rotation and is carried out by means of an integral hydraulic motor driving a Worm Drive Unit, around a Slew Gear.

DRIVE & STEER SYSTEM

An electronic controller, mounted in the chassis, is pre-programmed to adjust the upper speed limit of each individual function. The controller limits the rotational speed of the electronic motor and oil pump, thereby limiting the maximum oil flow rate.

The following functions are controlled and driven by the electro-hydraulic system:

- Traction Drives (Fwd & Rev) mast stowed/mast raised.
- Steering and Jib elevation.
- Mast elevation, descent and rotation.
- The Jib descent function is gravity operated and is determined by built in flow regulators.

POWER SYSTEM

The Power System (Prime Mover) incorporates four 6V batteries driving a 4KW electro-hydraulic pump. The pump drives all hydraulic cylinders and the traction drive motors. A single multi-valve control block diverts the oil pressure to the individual actuators. The oil flow rate is limited by the pre-programmed speed setting on the motor but is determined by the position of the joystick in the Upper Control Box.

1.3 WORKSHOP PROCEDURES

All information contained in this manual is based on the latest product information available at the time of printing. We reserve the right to make changes at any time without notice.

No part of this publication may be reproduced, stored in retrieval system, or transmitted, in any form by any means, electronic, mechanical, photocopying, recording, or otherwise, without the prior written permission of the publisher. This includes text, figures, and tables.

CAUTION

Detailed descriptions of standard workshop procedures, safety principles and service operations are not included. Note that this manual does contain warnings and cautions against some specific service methods that could cause personal injury, or could damage a machine or make it unsafe.

Please understand that these warnings cannot cover all conceivable ways in which service, whether or not recommended by UpRight, might be done, or of the possible hazardous consequences of each conceivable way, nor could UpRight investigate all such ways.

Anyone using service procedures or tools, whether or not recommended by UpRight must satisfy themselves thoroughly that neither personal safety nor machine safety will be jeopardized. When in doubt, contact your local distributor or UpRight.

2. Operation & Specifications

2.1 INTRODUCTION

SPECIAL LIMITATIONS

The purpose of this machine is to provide fast and safe access to difficult to reach areas.

Refer to the Specification section for the machines access limitations.

Travel with the platform raised is limited to creep speed range.

MANUAL FORCE

Manual force is the force applied by the occupants to objects such as walls or other structures outside the work platform. The maximum allowable manual force is limited to 200 N (45 lbs.) of force per occupant, with a maximum of 400 N (90 lbs.)

! D A N G E R !

DO NOT exceed the maximum manual force.

NEVER exceed the platform capacity.

PLATFORM CAPACITY

The Platform is designed to travel with safe working load (**SWL**) including work tools to an upper limit of **215 kg (475 lbs)**.

BEAUFORT SCALE

Never operate the machine when wind speeds exceed 12.5m/s (28 m.p.h.) [Beaufort scale 6].

BEAUFORT RATING	WIND SPEED				GROUND CONDITIONS
	M/S	KM/H	FT./S	M.P.H.	
3	3,4~5,4	12,25~19,4	11.5~17.75	7.5~12.0	Papers and thin branches move. Flags wave.
4	5,4~8,0	19,4~28,8	17.75~26.25	12.0~18	Dust is raised, paper whirls up, and small branches sway.
5	8,0~10,8	28,8~38,9	26.25~35.5	18~24.25	Shrubs with leaves start swaying. Wave crests are apparent in ponds or swamps.
6	10,8~13,9	38,9~50,0	35.5~45.5	24.5~31	Tree branches move. Power lines whistle. It is difficult to open an umbrella.
7	13,9~17,2	50,0~61,9	45.5~56.5	31.~38.5	Whole trees sway. It is difficult to walk against the wind.

! D A N G E R !

DO NOT use on soft ground or on slopes greater than 2 degrees.

The work platform is **NOT** intended for use on uneven or rough terrain.

ONLY operate this machine on **FIRM** and **LEVEL** ground.

2. Operation & Specifications

2.2 GENERAL DESCRIPTION

The MB20/26 are self propelled, fast acting aerial work platforms, designed to raise two operators with hand tools to a platform floor height of 6.00m and 7.76m respectively. The accessible height is approximately 2.00m above these figures.

The unit offers the ability to reach over obstacles but **must** be used on firm and level ground at all times.

! D A N G E R !

DO NOT use the lifting mechanism to raise or lower goods or persons except within the cage and subject to the specified weight limitations.

! D A N G E R !

DO NOT enter the platform from any structure, rack or other platform.

Figure 3: Work Platform



! W A R N I N G !

DO NOT use the work platform without safety drop-bar in place and with the safety harness fitted.

2.3 SAFETY INSPECTION

This Safety Inspection shall be carried out by the owner immediately prior to transporting this machine.

This Safety Inspection shall also be carried out by the user **prior to use each day**.

The procedure is to carry out the following 14 checks in order as follows.

1. Remove the rear chassis covers by means of the two top twist-locks and the two lift-and-turn catches at the sides. The cover is removed by sliding it backwards and upwards. Use the central handle provided.
2. Ensure that the mast and jib are fully lowered. Remove the hydraulic oil filler cap and check that the hydraulic oil level is correct. Oil should be visible on the dip stick. Top up as necessary using hydraulic oil Viscosity Grade ISO 46.
3. Inspect the chassis area for oil leaks, loose parts, frayed cables and hoses and structural damage etc. Check that all cable connections to the solenoid valves are intact.
4. Open the Inspection hatches on both sides of the upper mast cover. Check that the AC mains cable is disconnected from the battery charger. Check the electrolyte level in each battery cell. Top up as necessary with distilled water only.
5. Use the automated battery top-up system fill the batteries to the correct electrolyte level. This is done by opening the shut off valve and pressing the green fill button for approximately 10 seconds, then re-closing the shut-off valve.

Batteries should be examined for cracks, acid leakage and terminal corrosion. Take corrective action immediately if either check fails.

Figure 3: Battery Fill Button & Valve

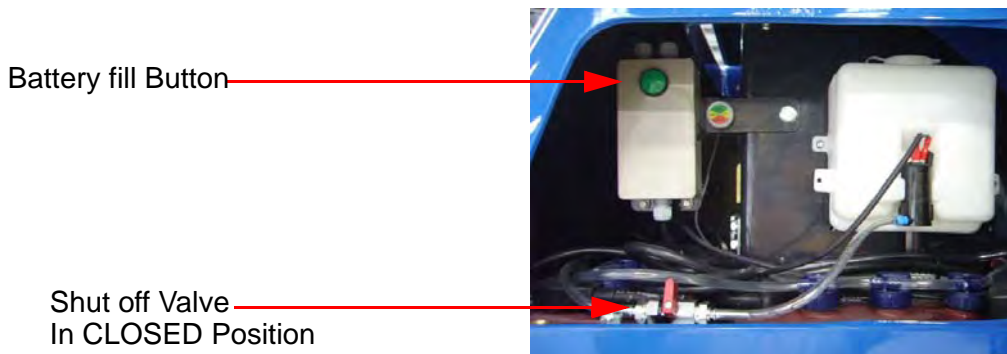

! CAUTION !

Vehicles fitted with the automated battery top-up system **with** shut off valve, top up the battery cells with distilled water using the electrolyte fill button, ensuring that the shut-off valve is open during the fill and closed after use.

This is the **only** time this valve should be opened.

Figure 4: Lower Control Panel

1. Enable Button
2. Analog Rocker
3. Mast Button
4. Jib Button
5. Rotate Button
6. Emergency Stop

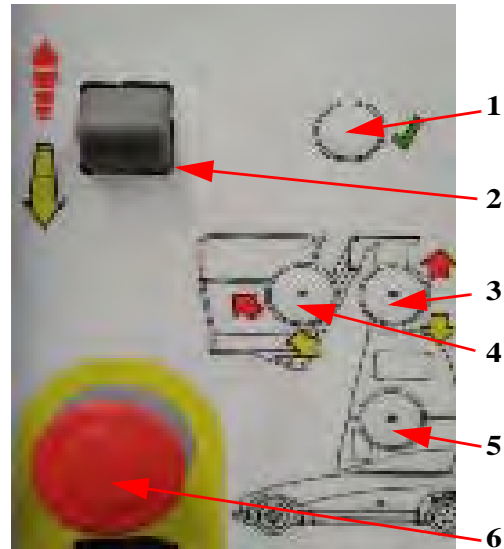

6. Prior to operating the functions, check that the upper and lower emergency stop buttons on each control station are retracted; turn clockwise if necessary. Carry out the following function from the Lower Control Station.

NOTE: DO NOT enter the platform at this stage.

7. Check jib operation by extending the jib to its fully elevated position. Check for correct routing of the hoses and cables. Check the Emergency Lowering feature of the jib. Ensure that when the Emergency Lowering lever/button is disengaged, the jib no longer descends. Return the jib to its rest position using the normal Lower Control Station.
8. Check mast chains by elevating the masts approximately 30cm above the rest position. Check for correct routing of the energy chain. Raise the masts to full height and check for correct adjustment of each lifting chain as follows. Each chain in the pair should bear load. Use a hand held spring balance or tensiometer apply a nominal load (approximately 10kgf.) to either chain in the pair. Apply the load about half way up the chain. Record the approximate deflection i.e. the offset distance from the mast. Repeat the measurement on the adjacent chain at the same location. Chains bearing equal load will deflect equal amounts. Carefully adjust the slack chain until the deflections are approximately equal. Torque up the locknuts to 70 Nm.

NOTE: Apply a thin layer of grease to the lifting chains with a small paintbrush.

! CAUTION !

Over-tensioning of either lifting chain will result in unnecessary lifting of the mast.

This will lead to a subsequent increase in machine stowed height.

2. Operation & Specifications

The function of the mast straps is to ensure that masts descend in the correct order and more importantly, that masts cannot continue to descend if the jib or platform meets an external obstacle. Raise the masts about 30cm. Check the external mast clamp screws for tightness. Pull on the short length of each strap and check that they are secure. Refer to the maintenance manual for instructions on more stringent periodic checks on these straps.

Check the Emergency Lowering feature of the mast. The lever is located in the upper mast over. Open the left hand battery inspection hatch and locate the 'Emergency Lowering' decal label. Check the wear pads for damage or heavy scoring. Replace as necessary.

9. Elevate the jib fully. Using the Lower Control Station, turn the mast assembly through about 90 degrees. Check the correct routing of the hoses and cables and the correct smooth operation of the energy chain in its chassis base slide. Continue rotating through 180 degrees in both directions. Confirm that the rotation stops are intact.
10. STANDARD PLATFORM CONTROLS Repeat the mast, jib and rotate functions from the Upper Control Station in the platform. Check that pressing the emergency stop button prevents subsequent operation of the joystick.
11. EMERGENCY OVER-RIDE While in the platform, ask a colleague to deflect the tilt alarm sensor body. This sensor is located on the chassis base. The alarm will sound and all normal function will become interrupted.

Figure 5: Joystick and Tilt Sensor

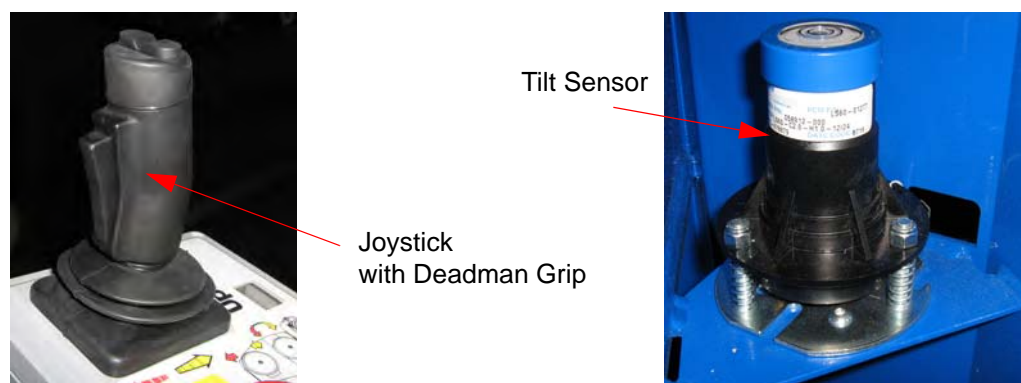

12. MACHINE TRAVEL - UNELEVATED Travel functions are possible only from the platform Upper Control Station. As with all such controls, the deadman handgrip switch must be depressed before any function can operate.

Select Drive on the upper control panel. Pushing back and forward on the joystick moves the machine backwards and forwards respectively.

The pothole protection will begin to retract immediately. However, full demand speed will not be realised until the bars are fully raised. This takes about 3 seconds. Check that the motion alarm DOES sound during travel. Check that the thumb operated switches on the top of the joystick operates the front wheel steering.

13. MACHINE TRAVEL-ELEVATED While the masts are raised, it is possible to drive and steer the machine at a much reduced speed. Also note that while the masts are raised, the pothole protection bars should be fully extended and should remain extended during slow speed motion of the machine.

W A R N I N G

The issue of reduced speed while elevated and deployment of the pothole protection bars is crucial to the safe operation of this machine.

The machine may not be released or operated unless these functions operate properly.

14. FINAL PREPARATION Configure the masts and jib to the stowed position. Replace all machine covers and secure.

NOTE: The machine is now ready for Operation or Transportation.

2.4 OPERATION OF THE PLATFORM CONTROLS

The primary (Upper) control box is permanently fitted to the front of the platform. It features a multi-use joystick which provides proportional control for all the machines functions. That includes, raising or lowering the mast, raising or lowering the jib, rotating the mast assembly, and also to drive and steer the machine.

A safety Interlock Switch or 'deadman button' is incorporated into the Joystick. It must be activated at all times in order to operate any function. This feature allows for one-handed operation.

The secondary (Lower) control box is fitted to the mast cover at arm level. It features an enable button and selector buttons to provide pre-programmed speeds for all functions except drive and steering. This control station is used primarily for service-type operations including pre-operation inspection. It should **never** be used to position a manned or un-maned platform.

NOTE: It may be used in the event of emergency to lower the manned platform.

W A R N I N G

NEVER operate the machine from the upper controls until the platform entrance drop-bar is in the fully lowered position and the safety harness is fitted.

CONTROLS AND INDICATORS

The pre-operation safety checks should be carried out prior to operation. These checks are detailed in the previous section. Operators who follow these guidelines will become familiar with the controls and indicators on the machine.

This section summarises the controls and indicators in tabular form and provides more detailed information.

! WARNING !

DO NOT operate the machine from the upper controls until the platform entrance drop-bar is in the fully lowered position and your safety harness has been fitted and attached.

UPPER CONTROL PANEL

Figure 3: Upper Control Panel

1. Joystick (forward/back)
2. Deadman Grip
3. Emergency Stop
4. Steering Switch (L/R)
5. Jib Select Button
6. Mast Select Button
7. Rotate Select Button
8. Drive (Slow)
9. Drive (Fast)
10. Key Switch

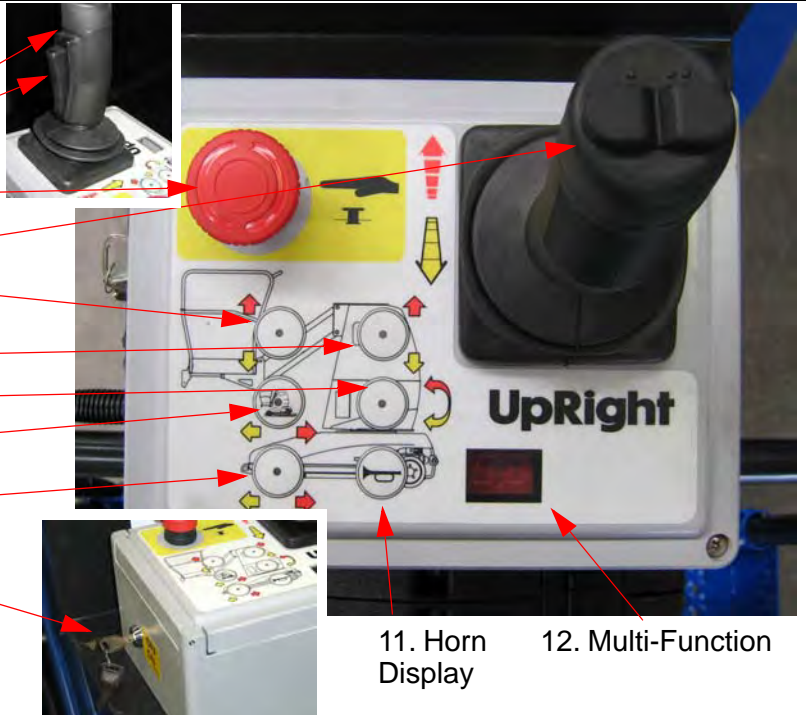

11. Horn Display

12. Multi-Function Display

CONTROL FUNCTIONS

ITEMS	NAMES	FUNCTION
1	Joystick	Refer to the decal logic diagrams for correct direction of motion. e.g. If Drive is preselected - pushing forward moves machine forward.
2	Deadman Grip	The 'Deadman' grip switch on the joystick must be grasped for any function to operate.
3	Emergency Stop	Push this red button at any time to isolate power. Turn clockwise to reset.

Table 1: Platform Controls and Indicators

2. Operation & Specifications

ITEMS	NAMES	FUNCTION
4	Steering Switch	Turns the wheels left or right.
5	Jib Select Button	Pre-selects the Jib function.
6	Mast Select Button	Pre-selects the Mast function.
7	Rotate Select Button	Per-selects the Mast Rotate function.
8	Drive (Mast Raised)	Pre-selects the drive function with the mast in the raised position and for high torque. (i.e. slow speed)
9	Drive (Mast Lowered)	Pre-selects the drive function with the mast in the lowered position. (i.e. maximum speed)
10	Key Switch	Activates (ON) and De-activates (OFF) all machine functions.
11	Horn Button	Use to warn bystanders or to attract attention.
12	Multi-Function Display	Displays the Percentage battery life. (99=Full, 01-Empty)

Table 1: Platform Controls and Indicators

LOWER CONTROL PANEL

ITEMS	NAMES	FUNCTION
1	Enable Button	This button enables the Rocker Switch, and must be held down during operation
2	Rocker Switch	Activates the pre-selected operation, in either direction
3	Mast Select Button	Pre-selects the Mast function.
4	Jib Select Button	Pre-selects the Jib function.
5	Rotate Select Button	Per-selects the Mast Rotate function.
6	Emergency Stop	Push this red button at any time to isolate power. Turn clockwise to reset.

Table 2: Chassis Controls and Indicators

Figure 4: Lower Control Panel

1. Enable button
2. Rocker switch
3. Mast selection button
4. Jib selection button
5. Rotate selection button
6. Emergency Stop

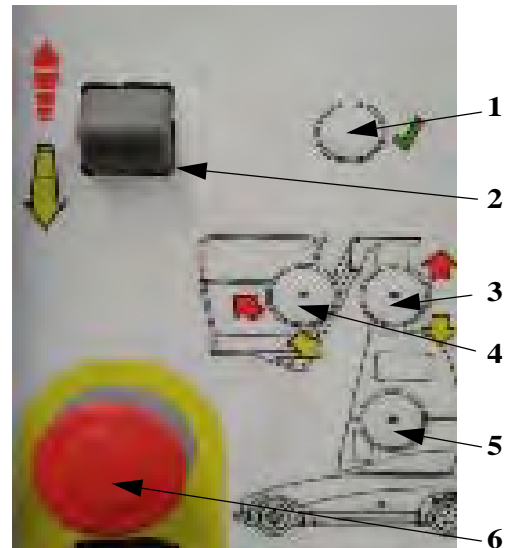

TYPICAL OPERATION

Raising the mast.

- The Keyswitch located on the Upper Control box must be turned on.
- Select Mast by pressing the Mast button (3)
- Press and hold the enable button (1),
- Activate the Rocker Switch (2) in the direction required.

ELEVATING & LOWERING THE WORK PLATFORM

Before operating the MB20 Work Platform it is imperative that the pre-operation Safety Inspection has been completed and any deficiencies have been corrected. The operator must also be fully trained in the use of this machine.

Before beginning any operation, the following checks should be carried out.

! WARNING !

ENSURE that no other persons are within 1 metre of the machine. Be aware of the pothole protection bar hazard on both sides of the machine.

LOOK up and around for obstructions before performing the lift or drive functions.

DO NOT overload the platform.

DO NOT operate within 3 metres of any electrical power cables.

THIS WORK PLATFORM IS NOT ELECTRICALLY INSULATED.

NOTE: Chassis controls are for service use only.

2. Operation & Specifications

1. Enter the Platform through the entrance at the rear of the MB20/26 and ensure that the drop bar is in position. Raise and lock the entry step by means of the pedal in the platform.
2. Before using the machine all local Safety Regulations involving helmets and restraining devices should be observed. Safety harness lanyards, not exceeding 1 metre in length, should be attached to anchor points in cage floor.
3. Ensure that the 'ON/OFF Key Switch on the Upper Control Box is turned to the 'ON' position and both emergency stop buttons are off (twist clockwise if necessary).
4. Check the Display L.E.D. is illuminated. If not, the battery may need recharging.
5. Check if the audible alarm sounds due to un-level ground. None of the functions can work if the machine is not level.

TRAVEL WITH WORK PLATFORM LOWERED

Refer to Tables 1 & 2 for controls and indicators.

1. Verify that both Lower and Upper Control Console Emergency Stop Button is in the 'ON' position (turn clockwise to reset).
2. Climb into the Platform and check that the Keyswitch is turned to the 'ON' position and that the Drive Button is illuminated. Ensure that the drop bar is in position.
3. Check that the route is clear of persons, obstructions, pot holes or ledges and is capable of supporting the wheel loads. Also, check that the clearances above, below, and to the side of the Work Platform are sufficient.
4. To steer the MB20/26, activate the Deadman Switch while pushing the Steering Thumb-switch, on top of the Joystick, LEFT or RIGHT to turn the wheels. Observe the tyres while manoeuvring to ensure correct direction.

NOTE: Steering is not self-centring. The wheels must be returned to the straight ahead position by operating the Steering Switch.

TRAVEL WITH WORK PLATFORM ELEVATED

CAUTION

If the machine stops driving and the Tilt Alarm sounds, lower the Platform **immediately**.

Using the Emergency Override functions, move the machine to a level location before re-elevating the platform.

Travel with platform elevated **ONLY** on firm and level surfaces.

Refer to Tables 1 & 2 for controls and indicators.

NOTE: The Work Platform will travel at reduced speed when in the elevated position.

1. Check that the route is clear of persons, obstructions, pot holes or ledges and is capable of supporting the wheel loads. Also, check that the clearances above, below and to the side of the Work Platform are sufficient.
2. Ensure that the pothole guards remain in the extended (down) position during elevated travel.

EMERGENCY SITUATIONS

In any emergency situation, the immediate action is to push the red “Emergency Stop” button. This will instantly cut off all electrical power to the controls. The button must be twisted in a clockwise direction in order to recommence control. However, the switch should be reset only when it is safe to do so.

If the Audible warning alarm sounds, normal control functions will cease to operate. This will be due to the following problem;

- The Tilt Sensor has been activated

NOTE: that during emergency operation, controls will operate only at a fixed, slow speed and will not allow the raising of the Booms. **The Booms can only be lowered.**

EMERGENCY LOWERING (BY HAND)

! CAUTION !

During manual emergency lowering, **extreme care** must be taken to ensure that the person carrying out the task is not struck by the jib or platform structure.

Should the machine become inoperable when elevated request a person on the ground to lower the platform using the emergency lowering valves. Lower the mast structure before lowering the jib/platform structure.

NOTE: Lower the masts fully before lowering the jib structure.

Figure 5: Emergency Lowering - Mast Valve

Locate the red lever behind the mast cover inspection door on the left hand side of the machine. By pushing the lever up, the mast will descend fully under gravity. Releasing the spring-loaded lever will cease this operation immediately if required.

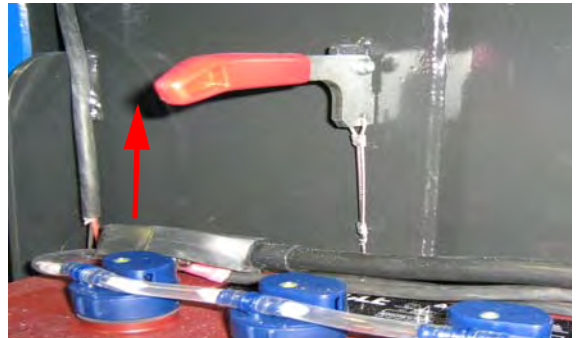

Figure 6: Emergency Lowering - Jib Valve

The Jib may be manually lowered by operating the manual release valve located between the Jib Structure.



MANUAL ROTATION

1. Lower the masts and jib fully before manually slewing the assembly. Press the Emergency Stop Button to prevent inadvertent powered motion.
2. Locate the opening behind the front right drive wheel. Apply a 7/8 inch socket wrench with extension bar to the shaft and turn to rotate the elevating assembly. (Turning the wheel fully to one side will facilitate this operation).

2.5 TRANSPORTATION

MACHINE WEIGHTS

Before transporting or lifting the MB20N/26 machine be aware of its weight. It is very important to realise that the centre of gravity of the stowed machine is approximately 80 cm above ground and in the plane of the energy chain which is located on the back of the mast.

MB20N CE Version= 2550 kg
MB20N US Version= 3000 kg (6615 lbs)

MB26 CE Version = 2650 kg
MB26 US Version = 3150 kg (6945 lbs)

In cases of particular difficulties with lifting or shipping it is possible to remove the single block ballast from the machine. Remove the 13 screws connecting the ballast cover to the mast. Undo the 4 bolts connecting the ballast to the mast and use a forklift to remove the ballast block. The ballast block weighs 850 kg on the CE version and 1300kg on the US (ANSI) version.

! WARNING !

This work must not be carried out without the prior written permission of UpRight Powered Access.

LIFTING BY FORK-LIFT

! DANGER !

Forklifting is for transport only. **See machine weights** and ensure that the forklift is of adequate capacity.

Figure 3: Lifting by Forklift

Adjust the forks so that the minimum clearance between them is 800mm as shown.

Approach the machine from either side but place the fork as close as possible to the front wheel as shown.

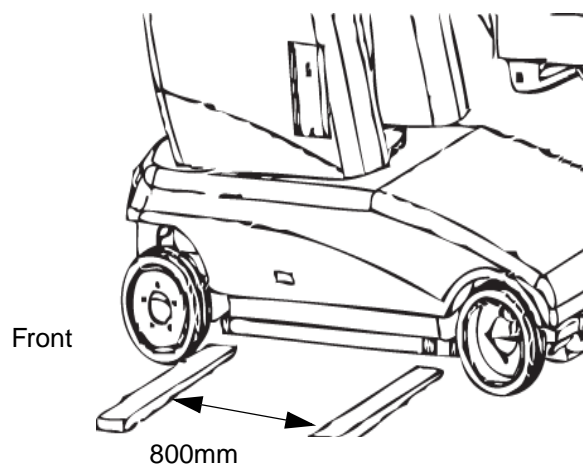

2. Operation & Specifications

1. Never approach the MB20 from the front or rear while fork lifting.
2. Use maximum forklift tilt as soon as possible when raising the MB20/26.
3. If travelling over sloped or uneven ground it is strongly recommended to temporarily tie the MB20 jib mount structure to the forklift mast as a safety precaution.
4. The MB20/26 may be lifted by forklift subject to the following strict procedure.
5. Ensure that the mast and jib are fully stowed and that the pothole bars are fully retracted (raised).

LIFTING BY CRANE

The MB20/26 may be lifted by an overhead hoist/crane subject to the following strict procedure.

Raise the jib to clear the lifting straps as shown.

Use 4 separate lifting straps connected to a spreader beam. DO NOT use a lesser number of threaded straps as these could slip and lead to instability. The recommended minimum capacity of EACH of the 4 straps is 2 tonne and the minimum length of each strap is 2 metres. Damage to the covers and/or cage rails can occur if a spreader beam is not deployed during a crane lift.

Figure 4: Lifting by Crane

Apply the straps via 1 tonne shackles to each of the 4 lifting lugs on the chassis.



! CAUTION !

DO NOT apply lifting straps to any other part of the machine.

TRANSPORT BY TRUCK

The MB20n/26 can be carried on a suitably rated transportation vehicle or trailer. Because of its high gradeability, the machine can be driven under its own power on to a standard loading ramp (Up to 14 degrees).

It is recommended to reverse the machine up on to the truck thus forward travelling down the ramp at the delivery point. Winch-assisted loading is allowable for larger slopes, however, operate the trucks assist winch at minimum speed to avoid over-pressurising the hydraulic system in the machine.

When the MB20n/26 is on the truck or trailer it should then be made secure by:-

1. Chocking the wheels.
2. Securing with adequate chains or straps to the lifting lugs on the chassis.

! CAUTION !

DO NOT loop straps through the cage, ladder or jib as this could cause permanent structural damage during transportation.

Figure 5: Securing the Platform

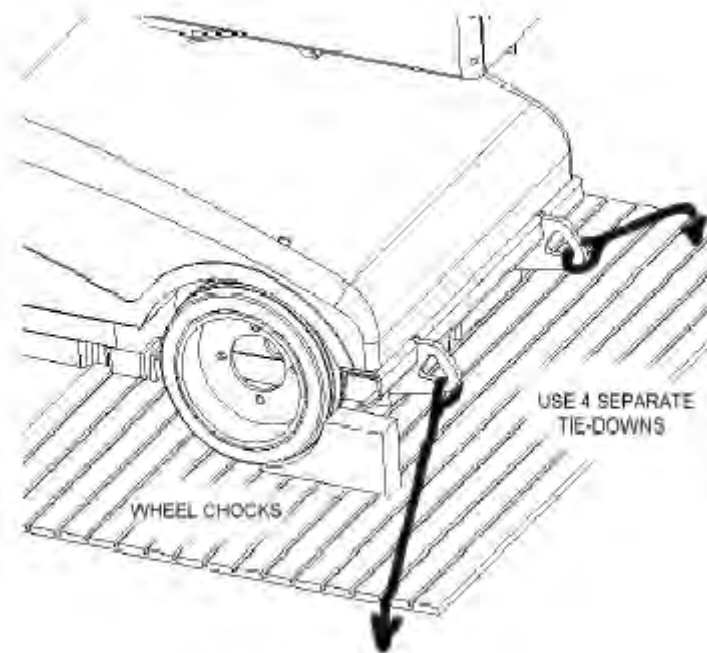

TOWING & WINCHING VALVES

The fail-safe brakes are automatically applied when the machine comes to a stop or in the event of total power loss due to low battery or malfunction of the hydraulic drive system.

To tow the vehicle or to winch it on to a truck it is necessary to hydraulically bypass the control valves and release these brakes.

2. Operation & Specifications

Proceed as follows:- (Refer to the valve block drawing Figure 6.)

1. Fully lower the jib boom and the mast sections. Rotate the mast into the stowed position.
2. Turn the Upper Control Box to the OFF position and remove the key.
3. Remove the rear GRP cover from the chassis and locate the hydraulic control valve block.
4. The hand valve marked 'A' should be turned fully clockwise to close. The hand valve marked 'B' should be turned fully anti-clockwise to open.
5. Operate the red handpump a number of times to develop sufficient pressure to 'separate' the internal brake disks. These brakes are integral with the hydraulic drive motors.

NOTE: The machine can now be safely towed or winched.

6. On completion of towing/winching, reverse the position of the rotary hand valves 'A' and 'B'. The handpump becomes inoperative when the valves are returned to their normal position.

Figure 6: Valve Block-Towing Valves

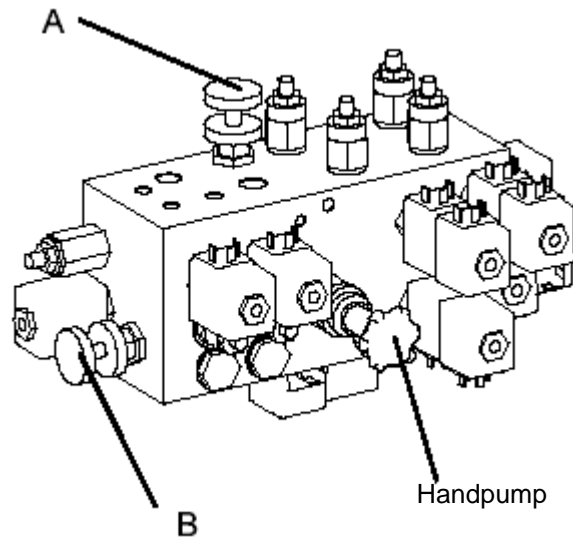

! WARNING !

RISK OF SERIOUS INJURY. Releasing the brakes will cause the machine to move uncontrollably on a slope. Damaging momentum can be developed due to the large mass of a slow moving machine

2.6 AFTER USE & STORAGE

AFTER USE EACH DAY

1. Ensure that the platform (masts and jib) are fully lowered.
2. Park the machine on firm and level ground, never on a grass surface.
3. Turn the key switch to the OFF position and remove.
4. Put the batteries on charge.

HOURLY METER

To access the hour meter function perform the following steps.

1. Climb into the basket (with the machine powered up)
2. Push the platform emergency stop button.
3. Hold down the following buttons, Horn and Lift.
4. While holding the buttons twist the emergency stop button to return power to the machine.
5. "hr." will now be displayed on the read-out, Pressing the right turn button will scroll through the accumulated hours two digits at a time. For example, if pressing the right turn button once displays "20", pressing it a 2nd time displays "58", and pressing it a 3rd time displays "hr.", the elapsed time of operation is 2058 hours.

LONG-TERM STORAGE

PRESERVATION

1. Clean and touch up damaged paint surfaces.
2. Fill the hydraulic tank to operating level with the platform fully lowered. Fluid should be visible on the tank dip stick.
3. Coat exposed portions of cylinder rods with a preservative such as multipurpose grease and wrap with barrier material.
4. Coat all exposed un-painted metal surfaces with a light oil or other preservative.
5. Cover the machine with tarpaulin if possible. If this is not available it is advisable to cover the mast and jib mount area as a minimum. This will prevent moisture from entering the mast, battery and chassis areas.

Figure 3: Battery Disconnect



Battery disconnect is located behind the controller

BATTERIES

1. Disconnect the batteries at the quick connect plug and socket. This is located in the chassis between the controller and the hydraulic tank.
2. Disconnect the battery leads and tape up the lead terminals to ensure insulation.

Better battery life and efficiency is achieved if the batteries are used consistently. It is therefore recommended that the batteries are used elsewhere if the machine is to be unused for an extended period (2 weeks or more).

! WARNING !

RISK OF SERIOUS INJURY. Take particular care when handling batteries. Acid spills can cause severe burns or blindness.

DO NOT store batteries close to naked flames or close to steel fabrication areas.

DAILY PREVENTATIVE MAINTENANCE CHECKLIST

Daily daily preventative maintenance will prevent abnormal wear and prolong the life of all systems. The inspection & maintenance schedule should be performed at the specified intervals.

Inspection and maintenance shall be performed by personnel who are trained and familiar with mechanical and electrical procedures.

⚠ WARNING ⚠

Before performing preventative maintenance, familiarize yourself with the operation of the machine.

Always block the elevating assembly whenever it is necessary to perform maintenance while the platform is elevated.

This Daily checklist has been designed for machine service and maintenance. Please photocopy this page and use the checklist when inspecting the machine.

MAINTENANCE TABLE KEY PREVENTATIVE MAINTENANCE REPORT

Y = Yes/Acceptable

Date: _____

N = No/Not Acceptable

Owner: _____

R = Repaired/Acceptable

Model No: _____

Serial No: _____

Serviced By: _____

COMPONENT	INSPECTION OR SERVICE	Y	N	R
BATTERY	Check electrolyte level.			
	Check battery cable condition.			
CHASSIS	Check hoses for pinch or rubbing points.			
	Check welds for cracks.			
CONTROL CABLE	Check the exterior of the cable for pinching, binding or wear.			
CONTROLLER	Check switch operation.			
DRIVE MOTORS	Check for operation and leaks.			
ELEVATING ASSEMBLY	Inspect for structural cracks.			
EMERGENCY LOWERING SYSTEM	Operate the emergency lowering valve & check for serviceability.			
ENTIRE UNIT	Check for and repair collision damage.			
HYDRAULIC FLUID	Check fluid level.			
HYDRAULIC PUMP	Check for hose fitting leaks.			
HYDRAULIC SYSTEM	Check for leaks.			
LABELS	Check for peeling, missing, or unreadable labels & replace.			
PLATFORM DECK AND RAILS	Check welds for cracks.			
TYRES AND WHEELS	Check for damage.			

Table 1: Daily Maintenance Checklist

SPECIFICATIONS

MB20N

PARAMETER	MB20N EU VERSION	MB20N US VERSION
Duty Cycle Platform Size Maximum Platform Capacity Maximum No. of Persons	45%over 8 hour cycle 780mm x 745mm 215kg. 2	35%over 8 hour cycle 31in. x 29in. 425lbs. 2
Heights: Maximum Platform Height Maximum Working Height Platform Height at Maximum Outreach	 6.00m 8.00m 5.04m	 19.69ft. 26.25ft. 16.54ft.
Maximum Working Outreach	2.64M	8.66ft.
Stowed Dimensions: Length Width Height	 2.222m 0.815m 1.990m	 7.97ft. 32in. 6.50ft
Chassis Ground Clearance Wheelbase x Wheel Gauge Rotation Gross Vehicle Weight Maximum Drive Speed - Stowed Maximum Drive Speed - Elevated Maximum Gradeability Outside Turning Radius	90mm 1465mm x 708mm 360deg non-continuous 2570kg. 3.03 km/h 0.70km/h 25% 1.85m	3.54in. 4.81ft. x 2.32ft. 360 deg non-continuous 6674lbs. 1.9mph. 0.43mph 25% 6.10ft.
Electrical: Power Source System Voltage Battery Charger Control System	 4 x 6V @ 375Ah Battery 24 Volt DC 24V x 30A, 220V 50Hz AC Single Joystick, Function Selector, DC Motor Controller	 4 x 6V @ 375Ah Battery 24 Volt DC 24V x 30A, 110V 60Hz AC Single Joystick, Function Selector, DC Motor Controller
Hydraulic System: System Relief Setting Hydraulic Oil Type Hydraulic Tank Capacity Brakes	 220bar ISO VG46 20 litres Spring applied hydraulically released	 3190psi ISO VG46 5.3 gallons (U.S.) Spring applied hydraulically released
Wheel & Tyres	13.5in. x 4.0 solid, Non-Marking	13.5in. x 4.0 solid, Non-Marking
Noise Pressure Level	68dB (A) at Control Station	68dB (A) at Control Station

SPECIFICATIONS

MB26

PARAMETER	MB26 EU VERSION	MB26 US VERSION
Duty Cycle Platform Size Maximum Platform Capacity Maximum No. of Persons	45%over 8 hour cycle 780mm x 745mm 215kg. 2	35%over 8 hour cycle 31in. x 29in. 425lbs. 2
Heights: Maximum Platform Height Maximum Working Height Platform Height at Maximum Outreach	 7.79m 9.79m 6.51m	 26.00ft. 32.00ft. 21.36ft.
Maximum Working Outreach	3m	10ft.
Stowed Dimensions: Length Width Height	 2.825m 0.990m 1.990m	 9.3ft. 39in. 6.54ft.
Chassis Ground Clearance Wheelbase x Wheel Gauge Rotation Gross Vehicle Weight Maximum Drive Speed - Stowed Maximum Drive Speed - Elevated Maximum Gradeability Outside Turning Radius	90mm 1465mm x 890mm 360deg non-continuous 2672kg. 3.03 km/h 0.70km/h 25% 2.10m	3.54in. 4.81ft. x 2.93ft. 360 deg non-continuous 7012lbs. 1.9mph. 0.43mph 25% 6.90ft.
Electrical: Power Source System Voltage Battery Charger Control System	 4 x 6V @ 375Ah Battery 24 Volt DC 24V x 30A, 220V 50Hz AC Single Joystick, Function Selector, DC Motor Controller	 4 x 6V @ 375Ah Battery 24 Volt DC 24V x 30A, 110V 60Hz AC Single Joystick, Function Selector, DC Motor Controller
Hydraulic System: System Relief Setting Hydraulic Oil Type Hydraulic Tank Capacity Brakes	 220bar ISO VG46 18 litres Spring applied hydraulically released	 3190psi ISO VG46 4.7 gallons (U.S.) Spring applied hydraulically released
Wheel & Tyres	13.5in x 4.0 solid, Non-Marking	13.5in x 4.0 solid, Non-Marking
Noise Pressure Level	68dB (A) at Control Station	68dB (A) at Control Station

NOTES:

3. Maintenance

3.1 INTRODUCTION

This section contains safety precautions which must be observed during the maintenance and servicing of the MB20 & MB26 work platforms.

Failure to adhere strictly to these instructions will result in personal injury to yourself or others and damage to the machine or the local environment.

Owners of this work platform must set up a maintenance programme and have prepared a safety statement in advance as required by the relevant National Body.

W A R N I N G

RISK of SERIOUS INJURY.

DO NOT undertake any mechanical, electrical or structural modifications to the design of this machine. Any departure from the normal use of the machine must be certified in writing from UpRight Powered Access Ltd. or other responsible authority.

Failure to abide by this instruction is a Safety Violation and a Warranty Violation.

3.2 MAINTENANCE SAFETY

The specific procedures and precautions for maintenance are detailed in Section 3.0 of this Manual. In general, the maintenance procedures and methods used are similar to those for heavy engineering machines which incorporate hydraulic, electrical and structural components.

Be aware that your safety and that of others is of the utmost importance when carrying out maintenance. The following basic principles should be applied:-

1. Never lift heavy weights without the aid of a mechanical device.
2. Do not allow objects to rest in unstable equilibrium even for short periods.
3. Always place supports under structural members.
4. Always presume that any action, no matter how insignificant, could result in the sudden and uncontrolled motion of machine parts under gravity.

W A R N I N G

Neither the manufacturer, UpRight Powered Access Ltd. nor its distributor has direct control over the field inspection, maintenance and safety of this machine.

This is the responsibility of the owner or operator.

HYDRAULIC SYSTEM SAFETY

The operating pressures within the hydraulic circuit are very high. Be aware that personal injury can occur if this pressure is released uncontrollably. Always presume that there is residual high pressure in a hose, pipe cylinder or valve body.

Take steps to eliminate this residual pressure by operating the booms and masts into their rest positions before carrying out any maintenance.

The MB machine should be maintained while on level ground only. This will ensure that the mast rotating mechanism and the running gear are stable.

The greatest risk to safety when maintaining the work platform is the sudden motion under gravity when a hose connection or built-in valve is loosened. The motion control valve is designed to prevent motion under gravity of cylinders in the event of a hose burst. However, loosening or partial removal of the hose burst valve will cause instant motion of the cylinder and the associated structural components.

NOTE: Oil spillages should be cleared up immediately. Avoid the temptation to do it later.

ELECTRICAL SYSTEM SAFETY

Take note that there is a facility to charge the batteries using an on-board charger. During this operation the machine is therefore connected to a potentially dangerous AC supply. Be conscious that ingress of water and or climatic conditions could result in circuit faults and the machine becoming 'live'.

There is a risk of burns caused by dead shorting of battery terminal.

The severe dangers associated with spilt battery acid and gaseous product are well documented.

Personnel must be fully aware of all these dangers before embarking on work platform maintenance.

SAFETY CHECKLIST

! W A R N I N G !

Failure to comply with the following safety precautions may result in death or injury of personnel or machine damage and is a safety violation.

- Ensure that lifting equipment including chains and straps are in good condition. Check the certification of all lifting gear.
- Provide independent supports for all booms, masts, jibs etc. before working underneath. Preferably, these support should be made up of a strong stable structure. Overhead slings or chains may be used only if the slings, chains and the supporting device such as crane, jib or hoist is certified for use as such.
- Use non-flammable cleaning solvents.
- Keep oil, grease and water wiped from floor surfaces and hand hold areas.
- Do not wear loose fitting clothing or neckties. These items and long hair may become entangled in rotating or moving machinery.
- Smoking is strictly forbidden. DO NOT weld or grind in the vicinity of the machine until the batteries are disconnected and removed.
- Remove rings watches and other jewelry when performing maintenance.
- Shut off all power sources and switches before embarking on maintenance.

WORKSHOP PROCEDURES

CAUTION

Detailed descriptions of standard workshop procedures, safety principles and service operations are not included.

Please note that this manual contains warnings and cautions concerning some specific service methods which could cause personal injury, or could damage the machine and make it unsafe.

Other service methods may be deployed to carry out a specific task, however, these methods may not be recommended by UpRight.

UpRight cannot investigate all possible methods nor can they warn against all possible dangers

Service personnel must be fully satisfied that neither personal safety nor machine safety is compromised.

WARNING

Where an abnormal situation is noted - for example damage to a part etc.

It is imperative that advice is sought from **UpRight Technical advisors** or from a suitably qualified person before continuing with maintenance.

It is very important to be aware of the potential dangers associated with maintaining these machines. Think carefully about the possible consequences of all actions before carrying them out.

Take particular precautions against dropping structures when working on the support components such as:-

- Cylinders
- Hydraulic hoses
- Hydraulic valves
- Pivot pins
- Chains
- Sequence Straps
- Chain Anchor Blocks
- Bolts & Screws etc.

Never attempt to repair the mast, jib or platform components while the assembly is partially elevated. In the event of failure of the assembly to descend by normal means use the emergency lowering valves as described in the Operators Manual.

If this fails then support the structure by means of an approved overhead lifting equipment or an approved adjustable support jack prior to loosening or removing any parts.

! D A N G E R !

Failure to carry out this instruction could lead to **serious injury or death.**

! W A R N I N G !

Where an abnormal situation is noted - for example damage to a part etc. - it is imperative that advice is sought from **UpRight Technical advisors** or from a suitably qualified person before continuing with maintenance.

TOOLS

The following special tools will assist in speedy repair and maintenance of the MB20/26 machines:-

- Multi-meter capable of reading DC Volts, Ohms and Amps.
- 1/4" standard quick -connect hydraulic pressure gauge - Range (0 - 300 bar)
- Calibrator Pt. No. 057128-000 - A test and analysis instrument for the D.C. motor controller.

THREAD SIZE	LOCATION	TIGHTENING TORQUE	
		METRIC	IMPERIAL
M4		3Nm	2.2lbs-ft
M6		10Nm	7lbs-ft
M8		25Nm	18lbs-ft
M10	Pin Lock Plates	40Nm	30lbs-ft
M10	Jib Mount Structure	50Nm	37lbs-ft
M12		80Nm	59lbs-ft
5/8-11unc	Slew Bearing	220Nm	165lbs=ft

Table 1: Torque Settings

! W A R N I N G !

RISK of SERIOUS INJURY.

Take particular care when handling batteries. Acid spills can cause severe burns or blindness.

DO NOT store batteries close to naked flames or close to steel fabrication areas.

3.3 GENERAL MAINTENANCE

This section contains information necessary to perform maintenance on the MB20 & MB26 work platforms. Procedures and techniques are designed to provide the safest and most efficient methods for scheduled maintenance and repair of the machine.

3.4 PREVENTIVE MAINTENANCE CHART

Preventive maintenance and inspection checks are listed in Tables on the following page. The table lists the components to be checked and the period between checks.

The keyword(s) within the boxes are self-explanatory in most cases, however, by way of clarification, these keywords are expanded in the legend which follows.

Items for inspection on the table are generally in order, starting at the ground and progressing upwards along the machine. For example, wheel bearings appear near the start of the list while the cage components appear towards the end.

All hoods and covers except for the ballast covers must be removed before proceeding with the preventative maintenance checks. This applies to the daily checks also.

It is a condition of warranty that machines are properly maintained according to this schedule.

MAINTENANCE TABLE KEYWORDS

Fixing	Check for secure installation and operation of the part.
Damage	Check for visible damage to welds and deformation of part or local structure.
Level	Check fluid level and top up as necessary.
Leaks	Check for signs of leak and correct the problem immediately.
Dirt	Check for excessive dirt causing overheating and possible short circuit.
Wear	Check for excessive wear on the part.
Torque	Tighten up per Tightening Torque Table
Lube	Lubricate per Lube Chart
Rod	Cylinder rod straightness. Fit a complete new cylinder if rod is bent.
Score	Check cylinder rod for abrasions
Change	Replace with Upright Spare Part.
Clean	Extract, clean and replace.
Replace	Part liable to become detached. Replace if missing.
Equalise	Battery maintenance procedure (see Battery Cell Equalisation)

MAINTENANCE SCHEDULE

	DESCRIPTION	DAILY	WEEKLY	MONTHLY	3-MONTHLY	YEARLY
	Chassis Base					
1	Chassis Structure			Damage	Clean	
2	Chassis Towing Points			Damage		
3	GRP Covers			Fixing		Replace
4	Tyres			Wear		
5	Wheel Studs		Fixing		Wear	
6	Hydraulic Drive Motors	Leaks				
7	Parking Brakes	Leaks				
8	Rear Wheel Bearings			Wear		
9	Steering Components		Damage		Wear	
10	Slew Bearing Motor	Fixing	Torque			
11	Slew Bearing & Housing			Lube		
12	Decals			Damage		Replace
	Drives Area					
13	Battery Cables		Dirt, Tight			
14	Electrical Terminals	Damage				
15	MOS 90 Controller		Dirt			
16	Line Contactor		Dirt	Wear		
17	DC Motor		Dirt			Wear
18	Hydraulic Pump					Wear
19	Main Hydraulic Valve	Leak				
20	Control Solenoids	Damage				
21	Valve Cartridges		Leaks		Fixing	
22	Solenoid Terminals	Fixing			Clean	
23	Hydraulic Hoses		Leaks			
24	Tilt Sensor	Fixing				
25	Hydraulic Tank		Level	Leaks		
26	Hyd. Return Filter Element			Change		
27	Hyd. Internal Suction Filter					Clean
28	Hyd. Filler Breather	Fixing				Replace
	Upper Structure					
29	Lift Cylinder Control Valve	Fixing				
30	Emergency Down Valve	Fixing				
31	Turntable Fixing Screws			Fix		
32	Lower Control Station		Damage			
33	Jib Rest Limit Switch	Fixing				
34	Main Lift Chain Anchors		Wear	Lube		Clean
35	Mid Chain Anchors		Wear			Clean
36	Chain Pulleys (Sheaves)			Wear		Clean
37	Wear Pads		Lube	Wear		Clean
38	Jib Platform Mounting Pins			Wear		
39	Platform Mounting		Damage			
40	Upper Control Station		Fixing			
41	Battery		Leaks	Equalise		
42	Main Lift Cylinder		Leaks	Damage	Rod, Score	
43	Jib Cylinder		Leaks	Damage	Rod, Score	

3.5 LUBRICATION

GREASE POINTS

Clean each fitting before applying grease. Using multipurpose grease (NLGI #1 or #2), pump the grease into the fitting using a gun until grease just begins to appear at the edges of the pivot pin. Wipe away excess grease.

Figure 3-1: Grease Points

PIVOT PINS

Apply grease liberally to the Pivot Pin and Pin Lock Plate locations using a brush or cloth. Force as much grease as possible between the Pins & Pin Lock Plates and the Weldments. Wipe away all excess grease.

LIFT CHAINS

Raise the masts to full height. Apply grease liberally to the external lift chains using a small paint brush. The main internal chain may be lubricated by removing the top cover from the jib mount structure. With the jib fully lowered, apply grease to the chain from the platform. The masts may be raised or lowered to expose the links. This operation should be carried out at monthly intervals.

SLEW RING

Using a brush, apply grease evenly and sparingly to the slew ring gear teeth. Do not subject this area to powerwashing.

3.6 REMOVAL OF COVERS

CHASSIS COVERS

Refer to the photo below for a description of the covers.

Figure 3-2: Chassis Covers



The rear chassis cover must be removed in order to access the majority of hydraulic and electrical components on the MB machines.

No tools are required to remove this cover and it is possible to remove and refit with the jib and cage in the stowed position.

Figure 3-3: Bonnet Catch

To remove the cover, loosen the 2 bonnet catches by twisting half a turn in the anticlockwise direction.

Undo the 2 side catches by pressing on the black tab lock, flipping out the tab and twisting 1/4 turn in the clockwise direction.

Turn to Open



Figure 3-4: Side Catch

When all 4 catches have been loosened it is then possible to remove the rear cover clear of the chassis.

To Open
Press & Twist Tab

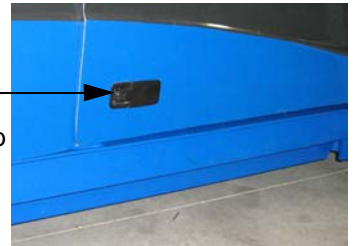

Figure 3-5: Central Handle

Use the central handle to lift the cover upwards and rearward in order to clear the chassis. Take care not to snag the electrical wiring when removing this cover.

Central Handle



It is not necessary to remove the small front cover on the MB range of machines except for replacement. To remove this cover undo the quick action captive screws which become visible after the rear cover has been removed.

MAST COVER

The mast cover must be removed to replace a battery or battery charger. Servicing of the batteries, however, does not require removal of this cover.

Mast cover removal is easier if 2 persons work together. Refer to the Figures below.

Before removing the cover, raise the mast assembly until the cage is about 2 metres clear of the ground.

Figure 3-6: Captive Screws

To remove the cover, undo the 4 captive screws connecting the cover to the ballast support plate. Undo the 2 similar screws at the back of the cover as shown in Figure 2-6.

Captive Screws

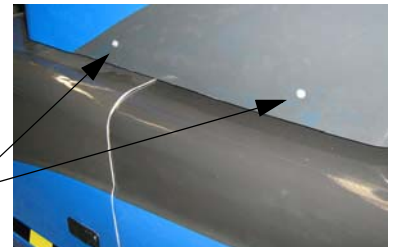

Figure 3-7: Mast Cover Removal

1. The rear 'wings' of the cover must be splayed out as shown while lifting the cover off its rest position.
2. Locate the lower control box cable within the left wing and undo the cable connector by turning it anticlockwise.
3. Store the cable end safely in the chassis.
4. Splay out the wings and lift the cover upwards until the front edge rests on the battery support plate.



Figure 3-8: Mast Cover Removal

5. Continue to lift the cover upwards and forwards until the wings are clear of the batteries.
6. Take care to ensure that the cover does not fall forward at this point as the centre of gravity of the cover is quite high relative to its midpoint.
7. Refitting of the covers is in the reverse order.



⚠ WARNING ⚠

Risk of Serious Injury

DO NOT remove ballast material from this machine. Stability is critically dependent on the weight of ballast as supplied from the factory.

3.7 JIB & PLATFORM ASSEMBLY

Regular inspection checks should be carried out on the jib and platform assembly. Pay particular attention to the following areas:-

1. Platform ladder mounting bolts and pivots
2. Ladder raising mechanism
3. Platform drop bar
4. Cage rail bolts
5. Jib to platform pivot pins & lock bolts
6. Jib to mast pivot pins & lock bolts
7. Jib cylinder hydraulic hose routing & fitting
8. Jib cylinder emergency lowering mechanism
9. Jib cylinder end pivots

LADDER

The machine should not be operated with a damaged ladder. Failure to replace a damaged ladder could result in injury. Do not repair a damaged or broken ladder. Use only plated bolts and nylok nuts when renewing the ladder pivots.

DROP-BAR

Replace damaged, missing or jammed drop-bars on the cage rails. It is not permitted to enter the platform unless it is fitted with an operational drop-bar.

! WARNING !

BEFORE commencing any work on the jib cylinder, jib cylinder valve, jib cylinder hose or jib cylinder emergency lowering mechanism, it is vitally important to either lower the jib completely or to support the assembly externally.

Failure to do this could result in sudden dropping of the jib during disassembly and consequential serious injury.

Figure 3-9: External Support

Overhead support load =125kg

Use certified crane straps only.
Always lift on a strong point.

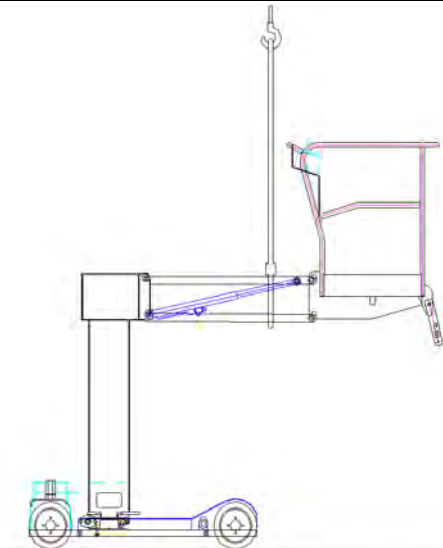

Figure 3-10: Boom Limit Switch

Before commencing work on the Mast Assembly ensure that the jib is fully lowered and approaching the reed switch as shown.

Reed Switch



! WARNING !

Failure to do this could result in sudden dropping of the jib during disassembly and consequential serious injury.

CAGE RAILS

The cage rails are fixed in position by means of 8 No. M8 ISO grade 8.8 bolts. Regularly inspect these bolts for damage and replace as necessary. The bolts should be tightened to a torque of 20.0 Nm.

The cage rails are manufactured from painted aluminium alloy. It is very important to thoroughly inspect the whole Jib & Platform assembly when broken or damaged rails are encountered.

PLATFORM & JIB REMOVAL

The platform assembly (steel base, aluminium rails, ladder sub-assembly and Upper Control Station) may be removed as a single unit. The total weight of this assembly is approximately 70 kg. Remove the rear chassis cover and proceed as follows:-

1. Disconnect the Upper Control Station cable from the underside of the box. Turn the plastic socket locknut anticlockwise and withdraw the pin connector. Take note of the socket orientation and the locating tabs to facilitate refitting later.
2. Remove the cable ties on the cage rail and platform base and secure the connector end against damage.
3. Remove the two M10 screws from the lock-plate retainers and slide the lock plates from the pin slots.

Figure 3-11: Retaining bolts

4. Remove the circlip, and using an arbour and mallet, tap out the upper jib-mount lower pin taking care to prevent the platform from swinging backwards uncontrollably.
5. Lower the platform backwards and downwards until it rests on the ground or on some temporary support on the chassis. In the case of the MB 20 machine, a common long pin is used to connect the jib cylinder and the jib strut to the jib-mount structure.

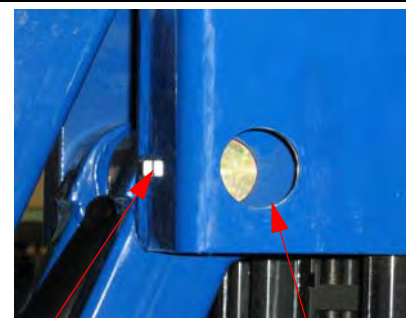

Retaining Bolt

Remove plastic cap to reveal circlip

NOTE: Take precautions to prevent the cylinder from

! WARNING !

The platform and cylinder **MUST** be supported before removing the Jib Pins.

Failure to do this could result in sudden dropping of the jib during disassembly and consequential serious injury.

6. Remove the lower pin in the same way.

7. Inspect the cylinder boss and the jib ends for bushing wear and replace as necessary.



8. When replacing the bushings it is important to first remove burrs and lightly oil the steel bosses. Use a small mallet and drift to fit the bearings. Take care not to score the ptfе/bronze coatings as this will greatly reduce the useful life of the bearing.
9. Assembly is in the reverse order of disassembly.
10. When replacing the pins, coat them in a light oil and align the steel bosses and bearings before tapping in the pin. Difficulties with pin fitting are normally caused by misalignment of the parts. Careful attention to alignment of the bosses before driving the pin saves time and minimises the risk of bearing damage. This applies to such assemblies throughout the machine.
11. Removal of the jib members follows in the same manner. The jib upper pins may be accessed by first removing the plastic caps from the sides of the jib-mount structure.
12. Disconnect the jib cylinder hose, solenoid cables and emergency lowering mechanism. Remove the remaining control cable ties from the jib members.

NOTE: Make a note of cables and hose routing in the area of the jib mount access hole. Incorrect re-assembly may result in cable pinching or shearing of either and considerable expense later.

13. Before removing the pins it is necessary to first remove the retaining circlips. Take care when removing the pin to support the jib cylinder which will become free before the jib member.
14. Use new circlip retainers and cable ties when re-assembling the jib members and jib cylinder.
15. Reinstall the cables and hose as per the original routing. Fix the control cable to the jib and platform rails by means of new ties.
16. Test the jib operation from the Lower Control Station initially. Inspect the cable and hose routing. Lower the jib by means of the emergency lowering lever. Test the operation of the jib, mast and slew etc. from the Upper Control Station. Malfunction at this point is most likely caused by an incorrectly fitted control cable connector at the base of the control station. Remove and refit taking care to correctly locate the plastic tabs within the connector.

3.8 SWITCH ADJUSTMENTS

JIB REST LIMIT SWITCH

FUNCTION

This limit switch is activated when the Elevating Assembly is fully lowered into the stowed position.

The limit switch is a magnetic reed type and is mounted on a bracket between the jib strut and the fixed mast. The high speed drive can only be operated when this switch is activated. When the boom leaves the boom rest the Normally Open contacts of the limit switch open and power is cut to the high speed drive function.

ADJUSTMENT

The switch itself is not adjustable and is not serviceable.

Check regularly for damage to the 2-core cable and clear the faces of contaminants.

The switch mounting brackets should be adjusted to give a maximum gap of 10mm between the magnetic faces of the switch.

TILT SENSOR SWITCH

! WARNING !

NEVER remove or over-ride this switch.

The machine may not be used unless the switch is in working order. To do otherwise could result in serious injury.

FUNCTION

This switch is activated when the internal sensor in the 'Tilt Sensor' is tilted 2° or more in either direction. This setting is preset at the factory and should on no account be adjusted. The sealed adjuster screws shall not be altered.

Doing so will invalidate the Warranty.

When the Tilt Sensor activates the elevating and telescope extend functions will be locked out and an audible warning alarm will sound. The Tilt Sensor has three wires;

Red- 24v power in
 Black- ground (earth)
 White- signal output 24v

LOCATION

The Tilt Sensor is fitted to the front left side of chassis frame as shown in Figure 3-14

Figure 3-13: Tilt Sensor

For models after and including:

MB-20N 204

MB-26 327

These units are sealed and pre-set and require no recalibration or adjustment.



ADJUSTMENT (for units before no's MB-20n 203 & MB-26 327)

To verify that the sensor is working properly proceed as follows.

Locate the two LED's under the sensor's plastic housing. The Green light indicates that the sensor is powered while the Red light indicates the sensor is not level with loss of 24v signal in the white wire.

1. Place the machine on firm level surface.
2. Use an level gauge to ensure that the front and rear of the Chassis are level to within $\pm 0.25^\circ$.

Figure 3-14: Tilt Sensor Spirit Level

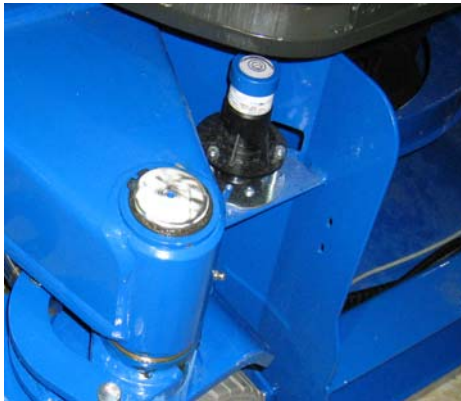

3. Adjust one of the 3 nuts until the bubble is level. Repeat the check and adjustment with the level gauge on the transverse axis of the machine.

Elevate the platform slightly until the jib limit switch is separated. Depress the joystick deadman button while a colleague manually tilts the sensor housing. The tilt alarm should sound and normal lift functions should be disabled.

3.9 MAST ASSEMBLIES

JIB-MOUNT STRUCTURE

Disassembly and re-assembly of the MB20/26 masts is a specialised task requiring special tools, jigs and fixtures. Structural damage to any of the masts requires a total replacement of the complete mast assembly by UpRight Powered Access.

Figure 3-15: Jib Mount Removal

Remove M10 screws & washers

Remove the covers to facilitate handling

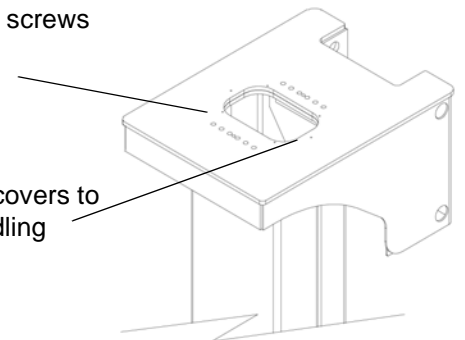

The jib-mount structure may be replaced as follows:-

1. Remove the platform and jib assembly as per the instructions in Section XXX.
2. Carefully route the hoses and cables through the openings in the back of the jib-mount weldment. Take note of the positions of hoses and cables to facilitate refitting.
3. Remove the cover plate at the top of the jib-mount to reveal the chain and pulley assembly.
4. Remove and discard the 12 No. M10 screws holding the jib-mount to the upper mast.
5. Remove the jib-mount from the top mast by lifting vertically upwards with a hoist. The jib-mount structure weighs 44kg.

! WARNING !

DO NOT attempt to repair this crucially important structural component.

6. Thoroughly inspect and clean the internal treads on the mast flange plate before re-fitting the jib-mount. DO NOT fit the jib-mount to the mast if any thread is damaged or blocked.
7. Do not lubricate the screw threads. Do not lubricate the internal threads. Use replacement screws M10 x 50, ISO Grade 8.8 only.
8. Tighten each screw using a short spanner. Gradually increase the torque in a cross-pattern, tightening each screw using a calibrated torque wrench to a maximum value of 65Nm.
9. Refit the dust cover.
10. Reassemble the platform and jib assembly as per the instructions in Section 2.5.
11. It is recommended to check the torque on the 12 screws after a number of working cycles of the machine.

WEAR PADS

Correct lubrication, replacement and adjustment of the mast wear pads is critical to the safety of the machine and to the comfort of the operator.

The two Upper-Rear pads being the most heavily loaded, should be replaced every two years or after 1500 hours work.

The Upper-Front pads will have a much longer life. The lower wear pads can be replaced during a major mast overhaul only.

Figure 3-16: Wear Pad Location

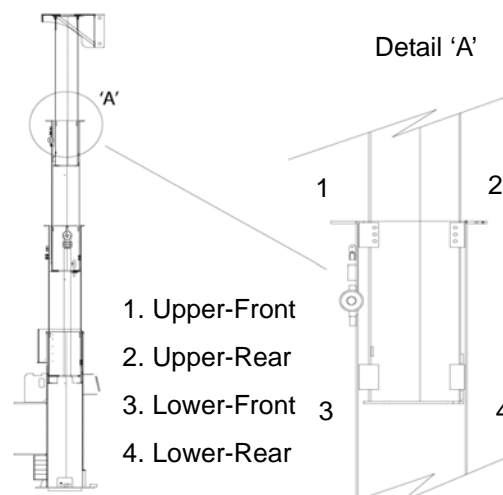

REPLACEMENT OF WEAR PADS

1. Fully lower the Platform assembly into the stowed position.
2. Raise the top mast section approximately 30cm. Wear pad replacement is facilitated if the platform is supported either by using an adjustable jack or an overhead hoist.
3. By means of a retainer (flat steel or bent wire) support the wear pad and prevent it from dropping into the mast.

Figure 3-17: Wear Pad Retaining Screw

4. Using a 4mm Allen key remove the 3 No. M6 button head screws and washers from the mast as shown in Figure 3-7.



5. Replace the worn pad with a new part. Retain and reuse the shim(s) if required. Replacement shims may be used provided they are of stainless steel or plated steel material. Use 1mm and 2mm thick shim material only. It is advisable to remove pads from one side (front face or back face) at a time. Do not fit shims beyond a total of 3mm as this will lead to excessive power consumption in the mast motion until the pads bed in.

LUBRICATION OF WEAR PADS

The lubrication of the internal wear pads is very important. Use a Molybdenum based grease. Fully raise the mast sections and apply grease with a brush on to the rear face of the mast in the way of the wear pads.

The front wear pads may be more conveniently lubricated using a heavy grade oil. It is desirable to lubricate the area beneath these wear pads as the loaded pads are at the base of the mast in each case.

3.10 CHAINS & STRAPS

CHAINS

Disassembly and replacement of the lifting chains on the MB20N & MB26 machines is a specialised task requiring special tools, jigs and fixtures. Damage to the chains requires a re-assembly of the mast sections.

Servicing of the lifting chains can be broken into 3 separate functions:-

- Chain Lubrication
- Chain Anchor Inspection
- Chain Tension Adjustment
- Refer to the maintenance table for chain lubrication periods. A light coating of grease should be visible on the chains at all times.

CHAIN ANCHOR INSPECTION & ADJUSTMENT

The chain anchors on the MB20N & MB26 machines can be inspected by adjusting the height of the masts until the anchor points come into view through the inspection opening.

Figure 3-18: Top Chain Ends, Mast-3

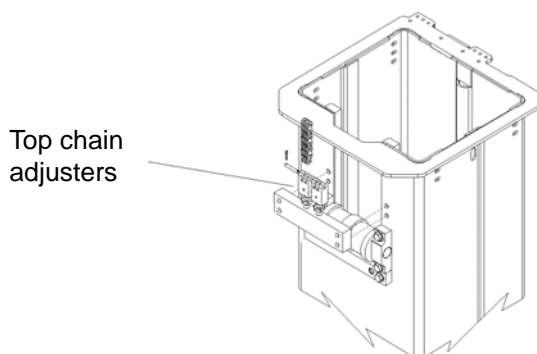

Figure 3-19: Top Chain Ends, Mast-5

Inspect the wear on the anchor block and anchor block cross-pin. Replace the pin and block if there is any visible signs of wear.

Also inspect the clamping bolts and central locating pin. Tighten

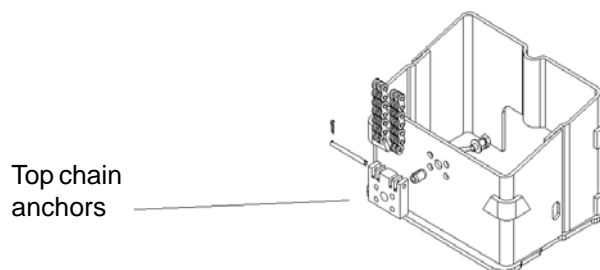
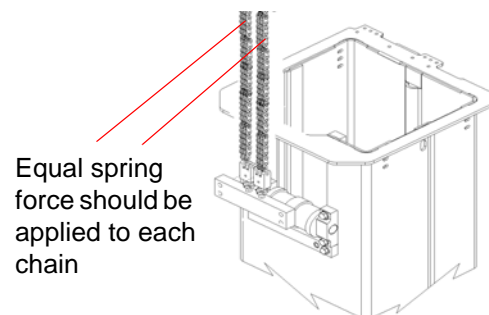

Figure 3-20: Chain Adjustment

The chains are selected to give adequate safety factors against breaking even if only one chain bears load.

However, it is absolutely imperative that each chain in the pair is loaded as evenly as possible throughout its life.



To adjust the balancing of chain tension proceed as follows:-

1. Extend the unladen masts to full height
2. Using a pair of identical compression springs, position each spring between the mid point of the external chain and the mast plating. The spring stiffness is not critical but a spring having the following approximate dimension will suffice.
 - Wire diameter - 2 to 3mm
 - Outside diameter - 40 to 50mm
 - Free length - 90 to 100mm
 - Measure the difference in outward deflection of each of the two chains in the pair.

3. If the differential dimension is greater than 6mm. then it is necessary to tighten the loose adjuster.
4. Return the masts to the fully lowered position and check the overall height of the mast assembly from the ground. Check that the nominal dimension is 1995 mm.
5. If this dimension has been exceeded during chain balancing, then it is likely that one of the chain pairs the chains has been overtightened, causing the masts to rise above the normal position. If this is the case then return to point 3. and balance the chains by slackening off the tightest adjuster.

Figure 3-21: Intermediate Chain Ends

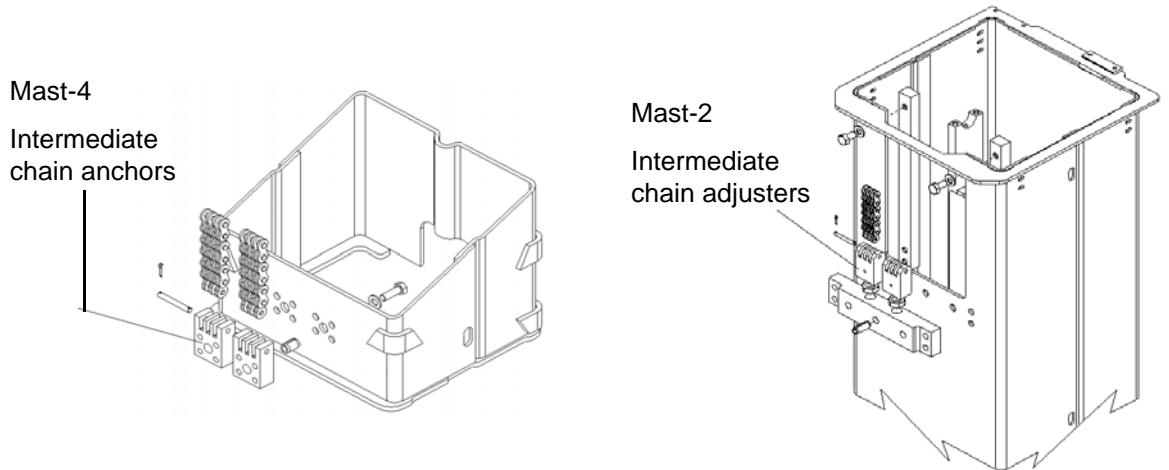

LOWER CHAIN ADJUSTMENT

The lower chain adjustment and inspection requires special consideration. Excessive slackness of the lower chain causes slamming of the chain during acceleration and deceleration of the machine during travel. To adjust the chain tension it is necessary to fully lower the mast assembly. Remove the chassis covers and locate the inspection cutout at the base of the fixed mast.

Figure 3-22: Lower Chain Ends

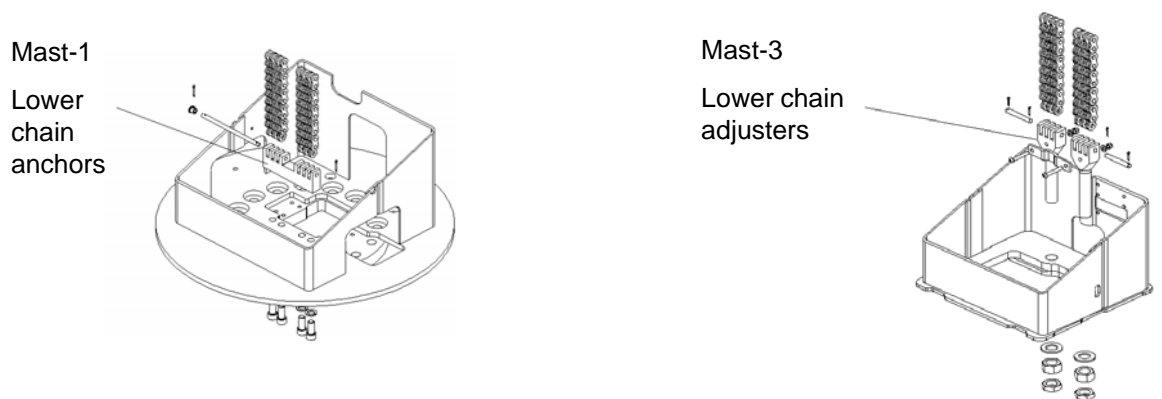

Check that the anchor pins are secured by means of the split pin as shown in Figure 2-22. Using a 22mm spanner adjust the nut at the base of the main chain adjusting end until the chain slackness is reduced to a minimum. There is no advantage to be gained in continued tightening of the chain. This will lead to raising of Mast-3 and loss of stowed height clearance. Balance the chain tensions by inspecting each chain from the top mast inspection hatch. Tighten the locknuts at the base of each chain tensioner.

3.11 WHEELS & STEERING

STEERING ASSEMBLY

Steering on the MB20 & MB26 machines is via a hydraulic cylinder mounted on the front of the chassis.

Figure 3-23: Front Steering Wheels

Two steering link arms provide extra tight turning ability and ensure correct geometry during a tight turn.

Each front wheel assembly (consisting of; mounting frame, motor, wheel & tyre) can be removed as a unit.

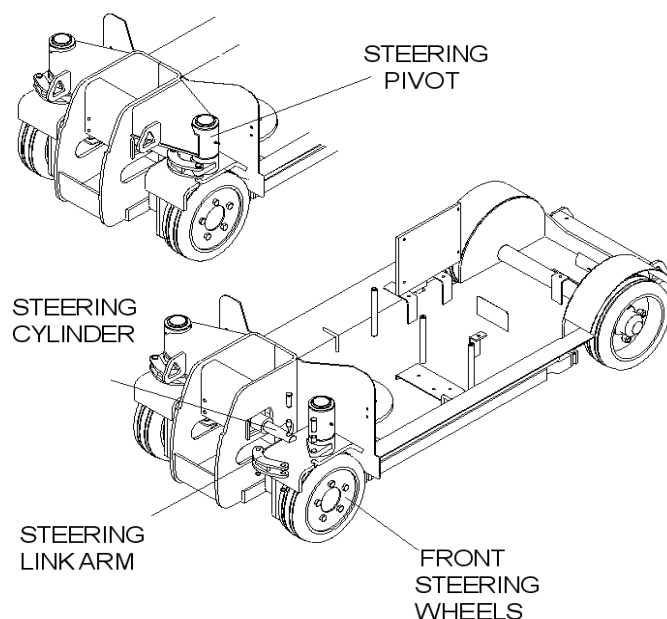

To remove a wheel assembly proceed as follows:-

1. Using a forklift or overhead hoist (refer to the Operators Manual for guidelines to the safe handling of the complete machine) support the machine chassis on 4 wooden or concrete blocks with an individual support capacity of 1 tonne each. In order to allow the wheel assembly to be removed it is necessary to chock the chassis about 15cm above floor level.
2. Turn the wheel fully to expose the hose connector swivel fittings. Remove the 3 hose connections and plug all hose ends and motor fittings.
3. Remove the steering link link arm by disconnecting the circlips and tapping upwards on the two-pins.
4. Take the weight of the wheel assembly by supporting the wheel from below by means of a wooden block or car jack. This facilitates removal of the circlip. The unit weighs approximately 70kg.
5. Remove the circlip from the pivot shaft and lower the assembly to the floor. The wheel, tyre and hydraulic motor may now be replaced as necessary.

Figure 3-24: Front Wheel Assembly

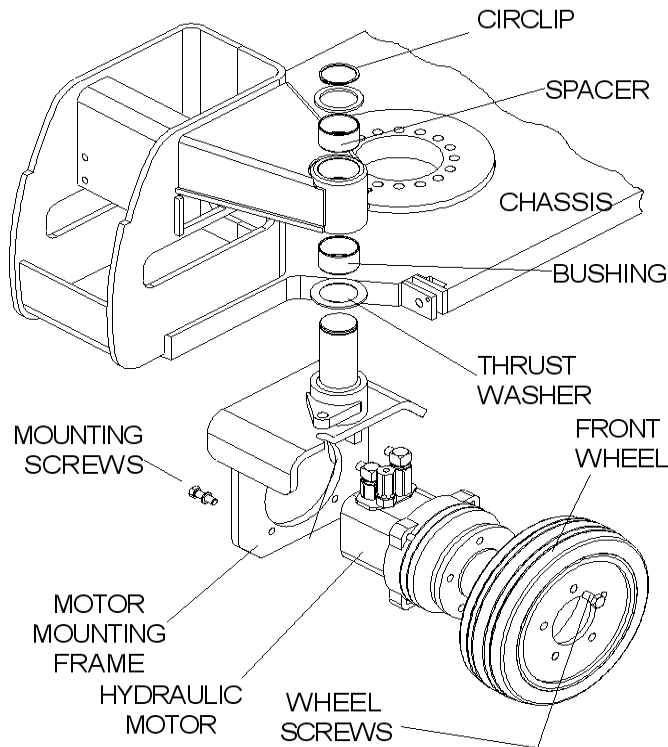

- Before re-assembling the unit, check that the grease nipple is free from dirt. Lubricate the pivot shaft and chassis pivot tube with grease. Lift the assembly into the pivot preferably using a forklift. The unit weighs approximately 70kg. Fit the spacer washer and a new circlip if necessary.

Tightening Torques:-

- Motor mounting screws - 80 N-m
- Wheel mounting screws - 45 N-m

3.12 HYDRAULIC TANK, OIL & FILTER

Fluid Level Check - every 50 hours

Figure 3-25: Hydraulic Tank Dip Stick

Check the oil level in the tank with the platform and jib fully lowered. Oil should be visible on the dipstick. If required, top up using hydraulic oil ISO Grade 46.

Topping up with the jib or mast raised could result in oil overflow during subsequent operation.



Do not remove filter gauze when filling

Filter Replacement - every 500 hours

It is strongly recommended to change the filter element in any case after each 500 hours work. To replace the filter element undo the 4 screws at the top of the filter body. Refer to Figure 3-26. The element is retained by means of the o-ring seal. Do not remove the replacement element wrapping until required - invisible contamination can cause damage to hydraulic components.

Oil Replacement - 3000 hours

Breakdown of lubricating capability of hydraulic oil may occur with time. It is recommended to completely change the oil after 3000 hours work.

When ingress of contamination such as dirt or water occurs the oil should be changed immediately according to the following instructions.

1. Operate the platform for 10-15 minutes to bring the hydraulic oil up to normal operating temperature.
2. Remove the inspection cover as shown in Figure 3-26. Use a barrel pump or similar device to remove the oil from the tank. Alternatively the tank may be removed from the machine and the drain plug used to empty the oil.

! WARNING !

ALWAYS recycle the used oil as per local environmental regulations.

3. The hydraulic tank has a capacity of 20 litres (5.3 US Gallons).
4. Clean the magnetic drain plug and re-install.
5. Disconnect the return hose and hose fitting from inlet port of the hydraulic return filter. Remove and replace the filter element as described above.
6. Fill the hydraulic reservoir with hydraulic oil (ISO VG 46) checking level with dipstick.
7. Check the hydraulic pressures whenever the pump, manifold or relief valve have been serviced or replaced.

Figure 3-26: Hydraulic Tank

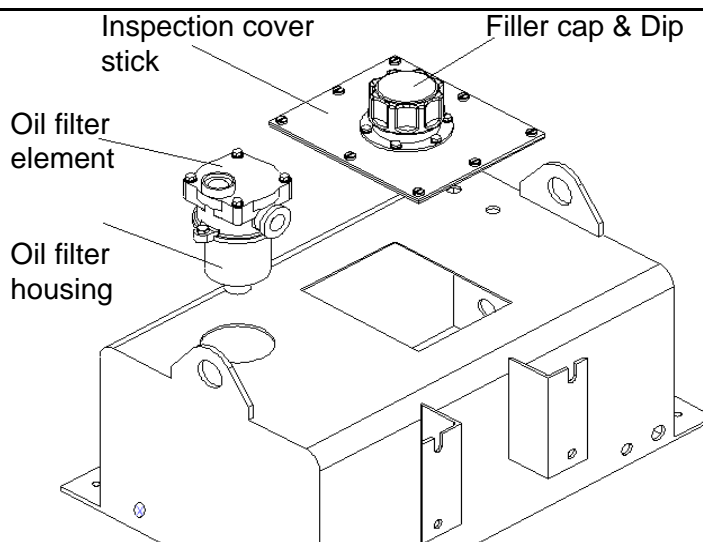

! CAUTION !

Wear safety gloves and safety glasses when handling hydraulic oil.

Oil can cause irritation of the skin. The oil remains hot long after use.

3.13 HYDRAULIC VALVES

OPERATING PRINCIPLES

CONTROL VALVES

This machine is fitted with 3-way, 2-position and 4-way, 3-position cartridge type directional control valves. When the circuit is activated and the solenoid activated, the spool shifts and allows oil to flow through the port and on to the desired activator (cylinder or motor). The spool is designed to allow oil to return from the activator to the tank at the same time.

A built-in spring returns the spool to the neutral position as soon as the solenoid is de-energised. Each directional control valve consists of a cavity in the block, the valve body, a sliding spool and one or two solenoids.

RELIEF VALVES

The primary function of a relief valve is to protect equipment from excessive pressures. The valve provides an alternative path back to tank for the oil if the actuator reaches its limit or if blockage problem arises in the circuit. The relief pressures are normally set about 20 to 30% higher than the load induced pressures to prevent loss of pressure energy and unnecessary heating of the oil.

POPPET VALVES

These valves are similar in operation to the directional control valves except that they have a single solenoid.

They are used to block or allow oil flow depending on the required logic. The functionality of these valves must be studied in conjunction with the Hydraulic Schematic.

PRESSURE SETTINGS

It is important to note some special features of the MB hydraulic circuits before embarking on pressure setting adjustments.

- The circuits are fitted with 2 system relief valves. The primary or Main Relief Valve protects the pump from over-pressure while the secondary or Lift System Relief Valve is used to limit the lifting capacity of the platform.
- A Cross-Line Relief Valve is fitted on the 'service' side of the slew control valve. This valve serves an important purpose. It limits the slewing pressure to that required for slewing only so that the jib cannot apply a large force to an external structure. This limit in turn prevents dangerous reaction torques on the structure which could cause tipping of the machine.
- Motion Control Valves are fitted to the drive circuit. These valves (CT 8 & CT 9) prevent over running of the drive and also prevent creeping of the machine while parked (assuming that the failsafe brakes are inoperable or have been previously disengaged). These valves are factory set and may not be adjusted under any circumstances.
- The function of the Drive Motor Relief Valve is to protect the circuit from excessive pressure build up during steering and driving of the machine. This relief valve (CT 25) is isolated during 'high traction' drive and serves no purpose. During 'standard drive' the motors are connected in series. Sharp steering combined with travel speed causes a build up of pressure between the hydraulic motors. The valve prevents excessive pressure build up between the lines. This valve is factory set and may not be adjusted under any circumstances.

MAIN RELIEF VALVE ADJUSTMENT

1. Operate the hydraulic system for 10-15 minutes to warm the oil.
2. Remove the rear chassis cover.
3. Insert a (zero-to-300 bar) pressure gauge into the high pressure gauge port on the Manifold Block.
4. Loosen the locknut on the Main relief valve (CT 10) and insert a 4 mm allen key into the hex head adjusting screw. Turn the key anti-clockwise about 2 full turns.
5. Carefully bring the machine to a halt against a solid obstruction and place a block of timber between the obstruction and the chassis.
6. Get a colleague to continuously drive the machine against the obstruction while the allen key is turned clockwise.
7. Continue turning the key until the pressure reads as follows.
 - MB 20 : 220 bar (3190 psi)
 - MB 26 : 220 bar (3190 psi)
8. Tighten locknut on main relief valve while holding the adjusting screw in position.

Figure 3-27: Main Relief Valves

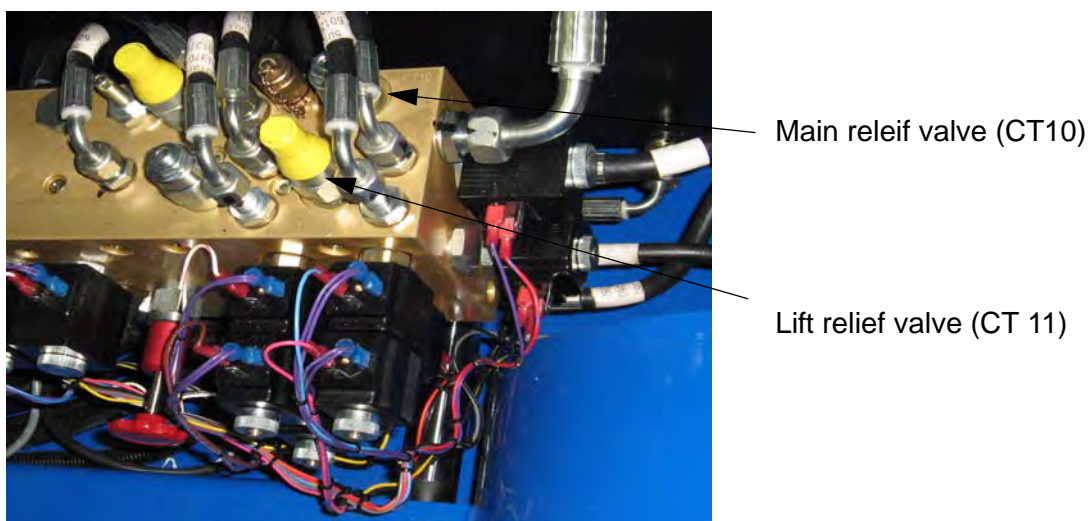

LIFT RELIEF VALVE ADJUSTMENT

1. Operate the hydraulic system for 10-15 minutes to warm the oil.
2. Remove the rear chassis cover.
3. Insert a (zero-to-300 bar) pressure gauge into the high pressure gauge port on the Manifold Block.
4. Loosen the locknut on the Lift relief valve (CT 11) and insert a 4 mm allen key into the hex head adjusting screw. Turn the key anti-clockwise about 2 full turns.
5. Operate the Mast Down function until the mast is fully bottomed out.
6. Get a colleague to continuously operate the mast down function while the allen key is turned clockwise.
7. Continue turning the key until the pressure reads as follows :-
 - MB 20 : 155 bar (2250 psi)
 - MB 26 : 180 bar (2610 psi)
8. Tighten locknut on lift relief valve while holding the adjusting screw in position.

SLEW CROSS-LINE RELIEF VALVE ADJUSTMENT

1. Operate the hydraulic system for 10-15 minutes to warm the oil.
2. Remove the rear chassis cover.
3. Insert a (zero-to-100 bar) pressure gauge into the high pressure gauge port on the Manifold Block.
4. Loosen the locknuts on both relief valve (CT 12 & CT 13) and insert a 4 mm allen key into the hex head adjusting screw. Turn the key anti-clockwise about 1 full turn.
5. Operate the Slew function until the mast strikes the mechanical slew stop.
6. Get a colleague to continuously operate the Slew function while the allen key is turned clockwise.
7. Continue turning the key until the pressure reads as follows :-
 - MB 20 : 50 bar (725 psi)
 - MB 26 : 50 bar (725 psi)
8. Tighten locknut on both relief valves while holding the adjusting screws in position.

Figure 3-28: Drawing of Valve Block

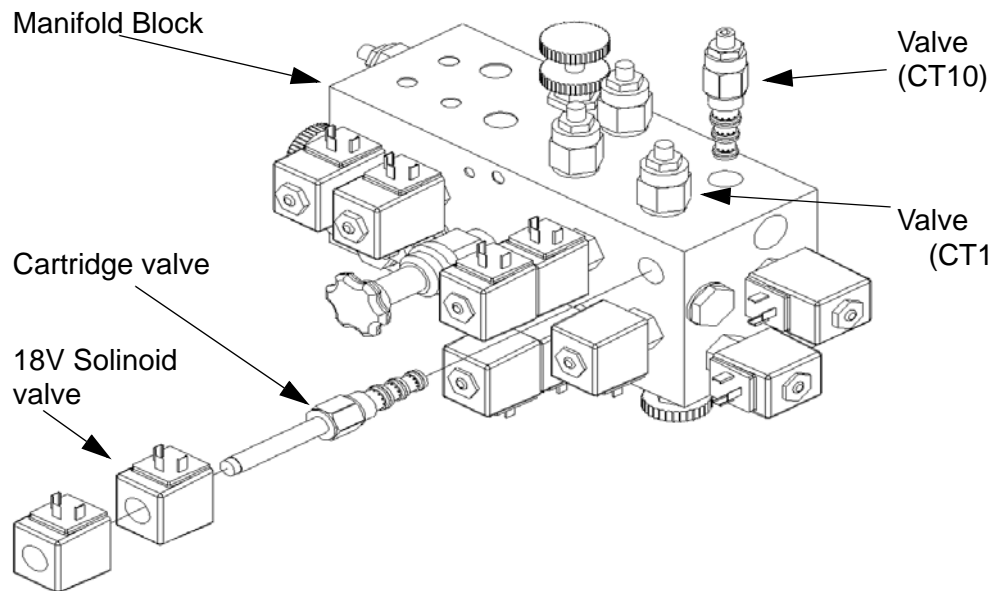

3.14 MANIFOLD BLOCK

The manifold block is suspended in position by means of two bolts on the tank bracket. Complete removal of the block is only necessary during a major overhaul of the hydraulic hoses or replacement of the block itself.

Most hydraulic problems can be solved with the block in situation, however, access to or replacement of some of the cartridges may be facilitated by dislocating the block temporarily. To do this, simply pull upwards on the block and rotate in position.

Use the Troubleshooting guides to ascertain the faulty cartridge and refer to the Hydraulic Function Legend for the designation and location of the suspect valve cartridge.

! CAUTION !

To avoid the risk of component damage the hydraulic hose ends should be tagged prior to disassembly.

Refer to the Hydraulic Schematic Diagram

MANIFOLD BLOCK REMOVAL

1. Remove the rear chassis cover.
2. Disconnect the Battery Disconnect Plug.
3. Tag and disconnect the solenoid valve leads.
4. Tag and disconnect the hydraulic hoses from the top face of the block.
5. Lift the manifold block from the two studs on the tank. Rotate the block to give access to the underside hose end fittings. Tag and remove hoses.
6. Plug all hose end fittings as a precaution against ingress of dirt or moisture.
7. Remove the manifold block to a clean bench.

DISASSEMBLY

1. Remove coils from solenoid valves.
2. Remove solenoid valves, relief valve cartridges, handwheel valves and screw in plugs from the aluminium block.
3. Remove the adaptor fittings and bonded washers.

! CAUTION !

To avoid the risk of component damage the Valve Cartridges should be tagged before removal. Each cartridge contains a spool design appropriate to the specific function.

Refer to the Hydraulic Schematic Diagram.

CLEANING AND INSPECTION

Where an overhaul is required on the hydraulic system - for example as a result of major contamination of the system, it is necessary to thoroughly clean and inspect the valve block.

Wash the manifold block in parafin, kerosene or similar cleaning solvent and leave to drain. Blow out all ports with compressed air.

! CAUTION !

Take precautions against airborne debris when carrying out this task.

ALWAYS Wear Safety Glasses.

Inspect the block for crack damage and check all ports for thread damage. Check the o-ring seal seats for score marks.

Check the spade connectors on the solenoid coils. Replace the coil if either of the outer connectors are broken (the central 'earth' spade connector is not used) As a precaution against damage to the coil spade connectors it is advisable to defer fitting the coils until the block has been secured and hosed up completely

ASSEMBLY

1. Install the cartridge valves, relief valves, over-centre valve, handwheel valves and screw-in plugs to their original positions.
2. Inspect each o-ring seal prior to fitting and replace as necessary. Do not fit the cartridge unless the o-ring seal is in good condition.
3. Install all port adaptors having checked all threads and inspected each bonded washer.

Apply the following torques to all components:-

- Cartridge Valves 20 Nm
- Relief Valves 45 Nm
- Overcentre Valves 45 Nm
- Coil Retainers 4 Nm

BLOCK INSTALLATION

1. Refer to the exploded view of the block before connecting the hoses to the male adaptors on the underside.
2. Check the hose routing on the chassis floor before tightening the hose fittings.
3. Locate the two screws on the back of the block into the slots in the tank bracket. Tighten or loosen off these screws until a snug fit is made between the block and the tank bracket. It is not necessary to adjust these screws after the block is properly suspended.
4. Connect the hoses to their correct destinations on the top and sides of the block.
5. Replace the solenoids and secure lightly using the narrow nuts and spacers where relevant.
6. Connect the solenoid leads to the spade connectors. If necessary, refer to the Electrical Schematic section for the correct colour coding of these cables.
7. Check each function (Up/Down, Fwd/Rev and Left/Right) before proceeding.
8. Secure the chassis cover to the chassis.

3.15 PUMP/MOTOR UNIT

REMOVAL

1. Remove the chassis rear cover and, if possible, elevate the platform and jib and rotate through 90 degrees. This is recommended to give more working space.
2. Drain or siphon off the hydraulic oil from the reservoir. The pump motor unit is located on the base of the chassis at the rear end.

CAUTION

Isolate the battery power by disconnecting the battery supply at the 'battery disconnect' plug & socket. This is located in the chassis behind the aluminium controller base-plate.

Failure to do this could result in electrical arcing at the motor terminals and damage to components.

3. Mark the hose ends and the motor cable terminals before removing the two hose connectors and the two electric terminals. Plug the hose ends to prevent ingress of contamination and oil loss..

WARNING

During these operations take care that screws, washers or other materials do not fall into the motor casing.

4. Using a large screwdriver, undo the pipe clamp clip (jubilee clip) holding the motor to the chassis. Remove the motor and service as required.
5. The pump is close-coupled to the motor and may be withdrawn by removing the four cap-screws. Match mark the pump and motor casing to ensure correct re-assembly.

INSTALLATION

1. Lubricate the pump shaft with a Molybdenum based grease and attach to the motor. Take care to orientate the pump ports correctly relative to the motor terminals. Tighten the 4 capscrews to 27Nm.
2. Refit the hoses.
3. Check the tightness of the port adaptor flange screws.

W A R N I N G

Be aware of the cavitation-induced damage caused to the pump if oil is not delivered to the suction port immediately..

4. Refill the reservoir. Check all operating functions and allow time for entrapped air to make its way to the reservoir return lines.
5. Fit the large diameter pipe clamp and rotate the pump motor unit until the terminals and pump hose adaptors are correctly orientated. Tighten the pipe clamp and fit the chassis cover(s).

3.16 LIFT CYLINDER

REMOVAL

1. Ensure that the machine is on firm level ground, the Elevating Assembly is completely stowed, the Keyswitch is to the 'OFF' position and the Emergency Stop Button is pressed.
2. Remove the chassis covers from the machine.
3. Disconnect the manual emergency lowering cable and mechanism from the base of the fixed mast.
4. Using a 30mm open spanner, slacken off the chain adjusting anchors at the base of the mast.
5. Remove the 8mm dia. x 150mm long chain anchor pin. Use a 5mm bar and a mallet to drive out this pin. Leave the 5mm drive pin in position until ready to undo the chain from the top pulley.
6. Remove the jib-mount top cover plate to expose the main chain pulley assembly.
7. Remove the four M8 x 50 long cap head screws from the pulley shaft bearing blocks.
8. The pulley and shaft assembly may now be withdrawn from its seat. Take care to first remove the temporary 5mm pin from the bottom end and to fold the chain out over the mast sections. It is not necessary to remove the main chain adjusting anchors.
9. Move the cylinder to a prepared work area. It is important that clean assembly practices are observed, as seals and other hydraulic cylinder components are sensitive to contamination.

Figure 3-29: Main Lift Cylinder Component Breakdown

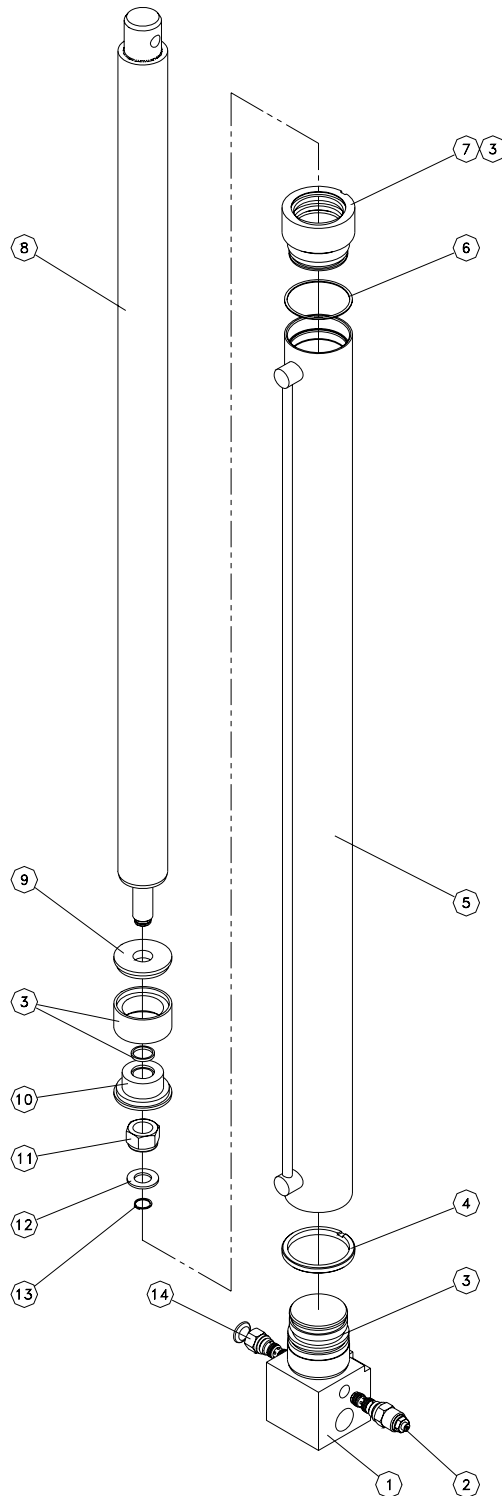

Note: The diagram shows a sample cylinder breakdown for the Upper Lift Cylinder.

Component Breakdowns of the other cylinders are shown in the Illustrated Parts Breakdown.

- 1 Body End Block
- 2 Overcentre Valve
- 3 Seals
- 4 Collor Locking Washer
- 5 Cylinder Body
- 6 Washer Tab
- 7 Rod End Cap
- 8 Cylinder Rod
- 9 Piston Head Cap
- 10 Piston Head
- 11 Lock Nut
- 12 Washer
- 13 Circlip
- 14 Emergency Lowering Valve

! CAUTION !

The Main Lift Cylinder weighs 55kg, utilise appropriate lifting equipment to support the unit before removing pins.

DISASSEMBLY

1. Unscrew the headcap and withdraw the rod and piston assembly from the barrel tube.
2. Unscrew the piston nut and remove piston and headcap from the cylinder rod.
3. Remove the piston static O-ring from the cylinder rod.
4. Remove the piston seal from the piston.
5. Remove the rod seal, rod wiper and static seal from the headcap.
6. Care should be taken to save the O-ring and all other seals for reassembly, if they have been deemed serviceable following the cleaning and inspection phase of maintenance.

CLEANING AND INSPECTION

1. Clean all metal parts in solvent and blow dry with filtered compressed air.
2. Check all threaded parts for stripped or damaged threads.
3. Check the bearing surfaces inside of the headcap, outer edge surface of the piston, inside of the cylinder barrel and the shaft for signs of scoring, pits, excessive wear or polishing. Scratches or pits deep enough to catch a fingernail are unacceptable. Polishing is a sign of uneven loading and if sufficiently polished the affected parts should be replaced.
4. Replace any parts or seals found to be unserviceable.

INSTALLATION

NOTE: Before installing the Lift Cylinder check the pivot pins and bearings for wear and replace if necessary.

REASSEMBLY AND SEAL REPLACEMENT

NOTE: During seal replacement do not use sharp edged tools. Take care not to cut the seals, and allow at least one hour for the seals to elastically restore to their original shape before assembly.

1. Lubricate and install new rod seal, rod wiper and static seal on the headcap.

NOTE: Multi-purpose lubricant should be used.

2. Install a new piston seal on the piston.
3. Install the headcap on the cylinder from the piston end.
4. Install the piston, piston nut and a new piston static O-ring on the cylinder rod. Screw nut to end of thread and secure with circlip.
5. Lubricate the piston seal and install the piston and rod assembly in the barrel tube.
6. Thread headcap onto barrel tube and hand tighten, then turn an additional 1/4 turn.

Install the lower cylinder Overcentre Valve.

3.17 BATTERIES

PRINCIPLES OF OPERATION

Electrical energy for the motor is supplied by four 6- Volt batteries wired in series to give a 24 volts DC supply. Each of these batteries consist of three cells supplying a maximum voltage of 2.2V each, i.e.6.6V at each battery or 26.4V for the full battery pack.

Proper care and maintenance of the batteries will ensure maximum performance from the work platform.

BATTERY POTENTIAL

Batteries do not reach full potential until they have been through 50 charge/discharge cycles (however the rate at which the potential increases is exponential, and the batteries will normally have 95% potential after 15 charge/discharge cycles). Hence do not use a new battery in a battery pack that already has more than 15 cycles. Charge batteries at the end of each work shift or sooner if batteries have been discharged. A battery is considered to have a faulty cell if it has less than 80% of the potential of the other batteries in the pack while measured under load.

When ambient temperatures fall below 18°C (65°F) batteries cannot deliver their rated Ampere hours and so should be placed on charge as soon after use as possible.

BATTERY CELL EQUALISATION

Specific Gravity is a measurement of the strength of the electrolyte in a battery and is measured using a hydrometer. For a fully charged battery the temperature corrected reading should be about 1.28.

Battery cells with specific gravity below 1.23 (after charging) are considered to be faulty and should be removed from the pack.

As the specific gravity is dependent on ambient temperature, the hydrometer reading must be temperature corrected using the following Correction Chart.

ELECTROLYTE TEMPERATURE		TEMPERATURE CORRECTED SPECIFIC GRAVITY, FULLY CHARGED	
FAHRENHEIT	CELSIUS	USA	EUROPE
120	48.9	1291	1.29
110	43.3	1287	1.29
100	37.8	1283	1.28
90	32.2	1275	1.28
80	26.7	1275	1.28
70	21.1	1275	1.28
60	15.6	1267	1.27
50	10.0	1263	1.26
40	4.4	1259	1.26
30	-1.1	1255	1.26
20	-6.7	1251	1.25
10	-12.2	1247	1.25
5	-15.0	1245	1.25
0	-17.8	1243	1.24
-5	-20.6	1241	1.24
-10	-23.3	1239	1.24
-15	-26.1	1237	1.24
-20	-28.9	1235	1.24
-25	-31.7	1233	1.23
-30	-34.4	1231	1.23

Table 2: Specific Gravity Correction Chart

3.18 BATTERY MAINTENANCE

BATTERY INSPECTION AND CLEANING

Check battery fluid level every day, especially if the work platform is being used in a warm, dry climate. Top up using distilled water only.

Tap water contains a high mineral content and will shorten the battery life.

W A R N I N G

Danger of explosive gas mixture.

Keep sparks, flames and smoking materials away from batteries. Always wear safety glasses when working with or handling batteries. Battery fluid is highly corrosive. Rinse away any spilled fluid thoroughly with clean water.

Batteries should be inspected periodically for signs of cracked cases, electrolyte leakage and corrosion of the terminals. Inspect cables for abrasion or breaks in the insulation and for broken cable terminals. Take corrective action immediately if check fails.

Thoroughly clean batteries using a 'baking soda' solution where corrosion is visible or where electrolyte has overflowed during charging.

Take care to avoid the solution entering the cells. Rinse thoroughly with clean, warm water. Clean battery and cable contact surfaces to a bright metal finish whenever a cable is removed.

C A U T I O N

If battery water level is not maintained the batteries will not recharge fully. This will result in a low discharge rate and damage to the windings on the Motor/Pump unit and **Warranty violation**.

There are 3 basic rules to achieve the maximum life cycle using deep-cycle traction batteries:-

1. Use the machine until it shows signs of weak/slow performance.
2. Allow the charger to charge the batteries until it automatically shuts off.
3. Avoid intermittent charging as the batteries can develop a memory effect similar to NiCad batteries.

BATTERY CHARGING

Before charging check that:-

1. The correct mains voltage and current is available to the charger.
2. The extension cord is in good condition and is no longer than 8m (26 ft.) and is 1.5 mm sq. (12 Gauge) or larger.
3. The Charger will turn on automatically after going through a self test sequence. LED's will indicate the status of charging.
4. The Charger Control Panel will indicate a fully charged battery pack.

! WARNING !

- DO charge batteries in a well-ventilated area.
- DO NOT charge batteries in the vicinity of sparks or flames.
- NEVER leave the charger operating unattended for more than two days.
- NEVER disconnect cables from batteries when the charger is operating.
- Permanent damage to batteries will result if they are not recharged immediately after discharging.
- Keep the charger dry.

Figure 3-30: Upper Control Panel with Battery Indicator

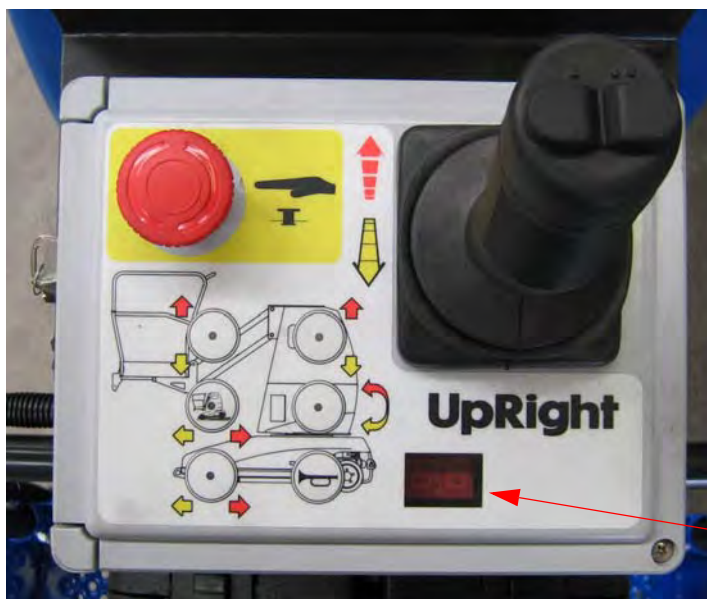

Battery charge indicator

! CAUTION !

DO NOT operate the machine while the charger is plugged in.

! CAUTION !

Incorrect voltage selection will result in permanent damage to the charger unit.

This is a Warranty violation.

BATTERY FLUID LEVEL

1. Open the Inspection hatches on both sides of the upper mast cover. Check that the AC mains cable is disconnected from the battery charger.
2. Check the electrolyte level in each battery cell. If electrolyte level is less than 10 mm above the top edge of the plates then distilled water must be added.
3. Use the automated battery top-up system fill the batteries to the correct electrolyte level.
 - This is done by opening the shut off valve and pressing the green fill button for approximately 10 seconds, then re-closing the shut-off valve.

Figure 3-31: Battery Fill Button & Valve

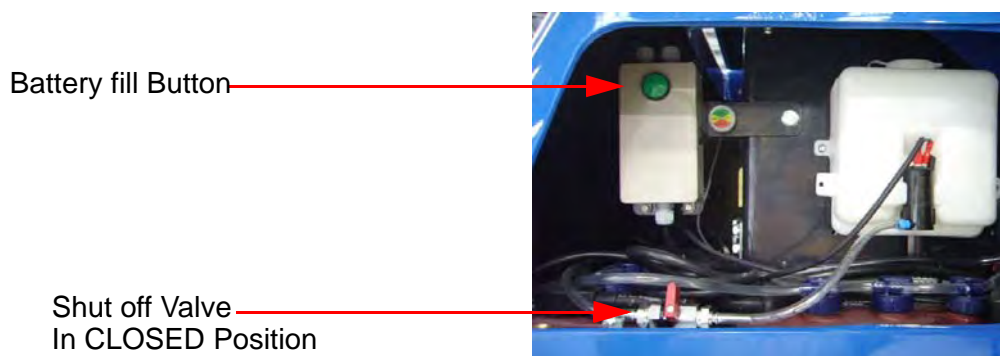

! CAUTION !

Vehicles fitted with the automated battery top-up system **with** shut off valve, top up the battery cells with distilled water using the electrolyte fill button, ensuring that the shut-off valve is open during the fill and closed after use.

This is the **only** time this valve should be opened.

4. Troubleshooting

INTRODUCTION

The following section provides troubleshooting guidelines to be used to locate and correct most of the operation problems which may occur. Problems which arise and which are not solved by the following corrective actions should be referred to a technically qualified person, as there is no substitute for a thorough knowledge of and practical experience in the servicing and repair of related equipment and machines.

For further assistance contact the local distributor and if warranted the UpRight Powered Access Product Support at:

UpRight U.K. _____ Tel: +44(0)845 1550 058

_____ Fax:+44(0)195 2985 228

UpRight Inc. U.S.A. _____ Tel:+1(559) 443 6600

_____ Fax:+1(559) 268 2433

Refer to the Operators Manual and to Sections 2 & 3 of this manual before proceeding.

W A R N I N G

Always ensure that the work platform is on a firm, level surface.

For any service that requires the platform to be raised, ensure that the platform and booms are supported by a suitable crane.

Unplug the machine or disconnect the battery when replacing or testing the continuity of any electrical component.

GENERAL APPROACH

Each malfunction is followed by a listing of probable causes which will enable determination of the remedial action. The probable causes and remedial action should be followed in the order in which they are listed in the following tables.

Note that the majority of problems will be related to the electrical and hydraulic systems. For this reason much attention has been paid to these areas in the troubleshooting charts. The lists are not guaranteed to include all possible causes and remedies. The immediately obvious causes and remedies are not necessarily listed.

1. Verify your problem.
 - Do a full function test from both the platform and chassis controls, and note all functions that are not operating correctly.
2. Narrow the possible causes of the malfunction.
 - Use the troubleshooting guide to determine which components are common to all circuits that are not functioning correctly.
3. Identify the problem component.
 - Test components that are common to all circuits that are not functioning correctly. Remember to check wires and terminals between suspect components. Be sure to check connections to battery negative.
4. Repair or replace any component found to be faulty.
5. Verify that repair is complete.
 - Do a full function test from both the platform and chassis controls to verify that all functions are operating correctly and that the machine is performing to specified values.

SPECIAL TOOLS

Following is a list of tools which may be required to perform certain maintenance procedures on the MX19 work platforms.

- Flow Meter with Pressure Gauge (**UpRight** P/N 067040-000)
- 0-69 bar (0-1000 psi) Hydraulic Pressure Gauge with Adapter Fittings (**UpRight** P/N 014124-010)
- 0-207 bar (0-3000 psi) Hydraulic Pressure Gauge with Adapter Fittings (**UpRight** P/N 014124-030)
- Adapter Fitting (**UpRight** P/N 063965-002)
- Inclinator (**UpRight** P/N 010119-000)
- Crimping Tool (**UpRight** P/N 028800-009)
- Terminal Removal Tool (**UpRight** P/N 028800-006)

ADJUSTMENT PROCEDURES

Hydraulic settings must be checked whenever a component is repaired or replaced.

Remove counterbalance valves and "bench test" them if they are suspect.

Connect a pressure gauge of appropriate range to the test port located on the hydraulic manifold.

Correct pressure settings are listed in the hydraulic schematic.

CHECKING PUMP PRESSURES

Remove hose from pump port and connect pressure gauge.

4.1 TROUBLESHOOTING TABLES

The next step is to refer to the Troubleshooting charts in Tables.

Refer to Hydraulics Section for detailed Troubleshooting information on the Pump/Motor Controller.

Read and understand the Principles of Operation before commencing any trouble shooting.

W A R N I N G

RISK of SERIOUS INJURY.

Ensure that the work platform is resting on a firm, level surface.

The elevating assembly must be supported by an overhead hoist when troubleshooting and servicing the electrical/hydraulic system.

4.2 GENERAL TROUBLESHOOTING

PROBLEM	CAUSE	ACTION
All functions inoperable. Electric motor does not start.	1. Blown main fuse	Check the 475A fuse and replace if necessary
	2. Faulty Battery Charger	Connect charger to batteries and check the output voltage. If less than 24v, repair or replace. Check input voltage to charger. Check the internal charger protection fuse.
	3. Faulty Battery	Charge batteries overnight. Check individual cell voltage. Replace as necessary.
	4. Loose or broken battery leads	Check resistance and continuity of each individual lead. Replace as required.
	5. Emergency Stop buttons contacts failed	Check resistance and continuity of each individual lead. Replace as required.
	6. Blown controller fuse 2	Remove the 7A fuse from its enclosure. Check continuity.
	7. Loose Upper Control Box Terminal	Unscrew connector, align locating tabs and reconnect
	8. Battery Disconnect plug loose	Check and reconnect. Check the internal steel points for pitting or damage
Electric motor starts but all functions are inoperable	1. Low hydraulic oil	Check and top up using ISO VG 46 hydraulic oil.
	2. Faulty hydraulic pump	Insert a pressure gauge in the G1 port of the valve block. Operate a function to the limit of stroke. Check that relief valve pressure develops. Repair or replace.
	3. Faulty controller	Check the 10mm cable terminals for tightness & Refer to Fault Codes.
Electric motor continues to run when action has ceased	1. Line contactor malfunction	Check the contact faces. Fusing or arcing due to contamination destroys the contacts. Replace the unit.
Pl.atform elevates very slowly or not at all	1. Leaking emergency lowering valves	Check the operating levers and cables. Check closure of the control knob at the base of the control valve block. Remove and replace the cylinder-mounted valves as necessary.
	2. Faulty lift valve solenoids	Test the voltage to the mast and jib solenoids. Swap around solenoids to isolate the problem. Solenoids are not serviceable.
	3. Platform overloaded	Remove excessive load. Check the pressure setting of the hydraulic 'lift limit' relief valve (CT11) on the block. This may only be reset at 215 kg payload in the platform.
	4. Incorrect controller speed settings	Check the programmed speed settings using the calibrator. This may be carried out by trained service personnel only.
	5. Low Battery level Check for fault code 68	Check the battery cell voltages after recharging. Total battery pack voltage should exceed 18v. Charge the batteries or replace faulty battery unit.
Platform drifts down uncontrollably	1. Leaking emergency lowering / hose burst valves	Check the operating levers and cables. Check contamination within the valve. Check closure of the control knob (CT14) at the base of the control valve block. Remove and replace the cylinder-mounted valves as necessary.
	2. Cylinder piston seal internal leakage	Switch off all power functions. Disconnect the hose from the annular side of the cylinder and check for small oil flow. Oil flow indicates a faulty cylinder piston seal. Remove and repair the cylinder.
	3. Platform is overloaded	Remove excessive weight. The Safe Working Load is 215 kg for MB20 & MB26.

PROBLEM	CAUSE	ACTION
Platform assembly will not slew	1. Faulty controller	Check the fault codes 57-58
	2. Faulty slew solenoid	Check voltage at the solenoid electrical connections. Use a screw driver or similar component to check the magnetic effect of solenoid.
	3. Incorrect cross-line relief setting	Insert a pressure gauge in the G1 port of the valve block. Operate a slew function and measure the pressure. Provided the main relief pressure has been preset properly, the gauge should register 20-50 bar. Reset or replace CT12 & CT13 thus preventing bypassing of oil.
	4. Faulty slew select switch	Replace the complete switch assembly.
Platform assembly will not descend	1. Faulty controller	Check the programmed jib and mast speed settings. Check the continuity of jib & mast speed enabling cables to the controller. Repair as necessary.
	2. Faulty mast or jib solenoids	Check the voltage to the solenoid CT 6 for the mast functions and CT 14 for the jib function. Swap solenoids to confirm fault and replace if necessary.
	3. Mechanical blockage in masts	Check the mast overlap sections and lift chain pulleys for foreign bodies. Inspect the mast wear pads for damage and excessive wear, replace and lubricate as required. Remove the jib-mount dust plate and inspect the main internal lift chain for dislocation, looseness or damage.
Pothole bar does not retract during Drive	1. Mechanical blockage due to damage to pivots or pins	Remove and repair the pivot plates or replace the weldment if this is bent.
	2. Faulty pothole solenoid	Check the voltage to the solenoid CT 7. Check the cables feeding the solenoids. Swap solenoids to confirm fault and replace if necessary.
	3. Pothole cylinder malfunction	Check the hose connections to the cylinder. Check the cylinder rod-end pins and the cylinder mounting screws.
Pothole bar does not extend during Lift	1. Mechanical blockage due to damage to pivots or pins	Remove - repair the pivot plates or replace the weldment if damaged.
	2. Faulty pothole solenoid	Check the voltage to the solenoid CT 15. Check the cables feeding the solenoids. Swap solenoids to confirm fault and replace if necessary. Check the correct function of the check valve CT 16.
	3. Pothole cylinder malfunction	Check the hose connections to the cylinder. Check the cylinder rod-end pins and the cylinder mounting screws.
Pothole bar does not remain extended during elevated Drive	1. Pothole cylinder malfunction	Check the cylinder pivot pins.
	2. Faulty pothole solenoid	Check that solenoids at CT 7 & CT 15 are energised simultaneously while the drive function is selected and the platform is elevated. Check the cables feeding these solenoids. Replace the solenoids if necessary. Check the valve cartridges for contamination.
Pothole bar drifts down when the machine is idle	1. Malfunction of check valve	Remove and service the check valve CT 16. Replace cartridge if in doubt.

Troubleshooting

PROBLEM	CAUSE	ACTION
Machine will not steer	1. Malfunction of joystick toggle switch	Check Fault codes 59 & 61. Remove and service the switch &/or joystick.
	2. Faulty steering solenoid & valve	Check that the solenoids at CT 1 are energised while the steering function is selected. Check the cables feeding these solenoids. Replace the solenoids if necessary. Check the valve cartridges for contamination.
	3. Faulty controller	Check Fault codes 59 & 61. Check the continuity of the steer speed enabling cable to the controller. Repair or replace as necessary.
	4. Steer cylinder malfunction	Check the hose connections to the cylinder. Check the cylinder rod-end pins and the cylinder mounting bolts.
	5. Seized wheel mounting frame pivot(s)	Refer to the maintenance section for assembly and repair of the pivot and associated parts.
	6. Damaged steering link plates	Replace the steering link plates, associated pins and lock plates.
Machine will not drive	1. Overload Fault code 03	Reset system and allow the system to cool down.
	2. Towing valve open	Locate the towing valve CT 21 on the valve block. Ensure that it is fully closed by turning clockwise.
	3. Hydraulic selector valve cartridge jammed	Locate the cartridge valve CT 3 on the valve block. Ensure that the internal spool is not contaminated and stuck in the 'Lift' position.
	4. Incorrect hose connections	Refer to the hydraulic diagram for correct connections of valve ports M1, M2, M3 & M4 to the motor ports. Incorrect connection may result in locking of wheels.
	5. Fail-safe brake-circuit malfunction	Blocked brake line to either motor. Clear blockage and/or replace hoses and fittings. Incorrect setting of cartridge valve CT 20 on the valve block. Open this valve fully for normal drive operation. Check the correct function of the check valves CT 30 and CT 17 on the valve block. These valve should open to allow brake chamber evacuation.
	6. Faulty Drive solenoid	Check that solenoids at CT 4 & CT 5 are energised while the drive function is selected. Check the cables feeding these solenoids. Replace the solenoids if necessary. Check the valve cartridges for contamination.
	7. Malfunction of the over-centre valve	Check the valve cartridges CT 8 7 CT 9 for contamination or mal-adjustment. Too low a setting on the adjusters will prevent motion of the drives. Too high a setting will cause over-running after attempting to halt the machine.
Machine travels in fast i.e. 'standard drive' mode only	1. Series-Parallel valve malfunction	Check that the cartridge valves CT 23 & CT 24 are not jammed in the energised position. Remove contamination and/or replace the cartridges.
Machine travels in slow i.e. 'high traction' mode only	1. Series-Parallel valve malfunction	Check that the solenoid on cartridge valves CT 23 & CT 24 are both energised simultaneously when 'high traction' is selected. Check wiring and connectors. Repair connections and replace solenoids as required.
Motor shaft seal extrudes	1. motor case pressure build-up	Check that the cartridge valve CT 24 is not jammed in the energised position while the circuit is in series ('standard drive') mode. Check that relief valve CT 25 is not set incorrectly. (50 bar). Prolonged tight turning of the machines during malfunction of CT 24 & CT 25 will cause build up of case pressure and subsequent shaft seal extrusion. Remove motor as per maintenance Section instructions and replace the shaft seal. this work may only be carried out by experienced hydraulic service personnel.

4.3 HYDRAULIC SYSTEM

HYDRAULIC FUNCTION TABLE

REF	NAME	FUNCTION	LOCATION
CT1	Directional control valve - Steering	Moves steering rod to left or right	Front face of block (double solenoid)
CT2	Directional control valve - Slew	Turns mast assembly left or right	Front face of block (double solenoid)
CT3	Selector valve - Drive/Lift	Diverts oil to either the drive or lift part of the circuit	Right hand face of the block (single solenoid)
CT4	Drive valve - Forward	Diverts oil to the drive motors	Front face of the block (single solenoid)
CT5	Drive valve - Reverse	Diverts oil to the drive motors	Front face of the block (single solenoid)
CT6	Directional control valve - Main lift	Raises or lowers the mast lift cylinder	Front face of block (double solenoid)
CT7	Poppet valve - Pothole bars	Extends the pothole cylinder	Right hand face of the block (single solenoid)
CT8	Over-centre valve - Drive motors	Prevents over-run of the drive motors. Piloted to CT9	Front face of the block (hex head)
CT9	Over-centre valve - Drive motors	Prevents over-run of the drive motors. Piloted to CT8	Front face of the block (hex head)
CT10	Pressure relief valve - Main system	Protects the pump from excessive pressure	Top face of the block (hex head)
CT11	Pressure relief valve - Lift system	Limits the jib lift to Safe Working Load	Top face of the block (hex head)
CT12	Cross-line relief valve - Slew	Limits the slew motor pressure to 50 bar. Diverts excess oil to tank	Top face of the block (hex head)
CT13	Cross-line relief valve - Slew	Limits the slew motor pressure to 50 bar. Diverts excess oil to tank	Top face of the block (hex head)
CT14	Directional control valve - Jib	Raises or lowers the jib lift cylinder	Bottom face of the block (single solenoid)
CT15	Poppet valve - Pothole bars	Retracts the pothole cylinder	Front face of block (single solenoid)
CT16	Check valve - Pothole circuit	Traps oil in pothole circuit	Right hand face of block (screw-in hex head valve)
CT17	Shuttle valve - Brake circuit	Provide high pressure to the braking circuit regardless of the drive direction	Left hand face of block (screw-in hex head valve)
CT18	Throttle Valve - Jib	Controls the rate of descent of the jib	Bottom face of block (screw-in hex head valve)
CT19	Plunger pump - Brakes	Provides manual means of disengaging brakes during an emergency	Front face of block (Red knob)
CT20	Brake over-ride valve	Closing this, normally open valve, allows plunger pump pressure to the brake chambers prior to emergency towing	Top face of block (Black knob)
CT21	Towing valve	Opening this, normally closed valve, allows bypassing of motor oil during emergency towing	Left hand face of block (Black knob)

Troubleshooting

REF	NAME	FUNCTION	LOCATION
CT22	Pressure reducing valve	Automatically limits the pressure in the brake chamber to 25 bar regardless of the operating pressures	Left hand face of block (Hex head)
CT23	Series/Parallel poppet valve	Switches between series and parallel connection of the motors	Left hand face of block (Single Solenoid)
CT24	Series/Parallel poppet valve	Prevents oil entering the anti-peak relief valve (CT25) during parallel connection of the drive motors	Bottom face of block (Single Solenoid)
CT25	Relief valve - series connection	Prevents damaging build up of pressures during a series- connected turn	Top face of block (Hex head)
CT26	Check valve	Allows low pressure oil to bypass CT25 during anti-cavitation function	Bottom face of block (Hex head)
CT27	Anti-cavitation valve	Allows low pressure oil to fill the possible vacuum formed during a series-connected left turn	Front face of block (Hex head)
CT28	Anti-cavitation valve	Allows low pressure oil to fill the possible vacuum formed during a series-connected right turn	Front face of block (Hex head)
CT29	Throttle valve - Steering	Controls the speed of operation of the steering cylinder	Top face of block (Hex head)
CT30	Check valve - Brakes	Allows oil to bypass the pressure reducing valve during normal operation	Top face of block (Hex head)
CYL1	Main lift cylinder	Raises/lowers the mast sections	Within the mast sections
CYL2	Jib lift cylinder	Raises or lowers the Jib and Platform assembly	Between the jib structural members
CYL3	Steering cylinder	Turns the front wheels left or right	Front chassis extremity
CYL4	Pothole cylinder	Automatically raises or lowers the pothole protection bars	Under the hydraulic tank
BRK1 BRK2	Failsafe brakes	Spring applied, hydraulically released brakes	Within the drive motor housings
MB	Manifold block	Houses all the hydraulic valves	Connected to the hydraulic tank
FL1	Return-line filter	Filters the returning oil continuously to 25 microns	Flange-mounted to the hydraulic tank
FL2	Suction strainer/filter	Filters the suction oil continuously to 40 microns	Screwed to inside of hydraulic tank (3/4")
MOT1 MOT2	Hydraulic motor	Drives the machine forward and backwards at various travel speed	Front end of chassis.
MOT3	Hydraulic motor	Drives the mast assembly through 360deg. (Slew)	Base of chassis. Coupled to the slew bearing assembly.
MP	Motor pump unit	Provides hydraulic pressure to the circuit	Chassis mounted towards the rear of the machine

Figure 4-1: Manifold Block with Valve Location

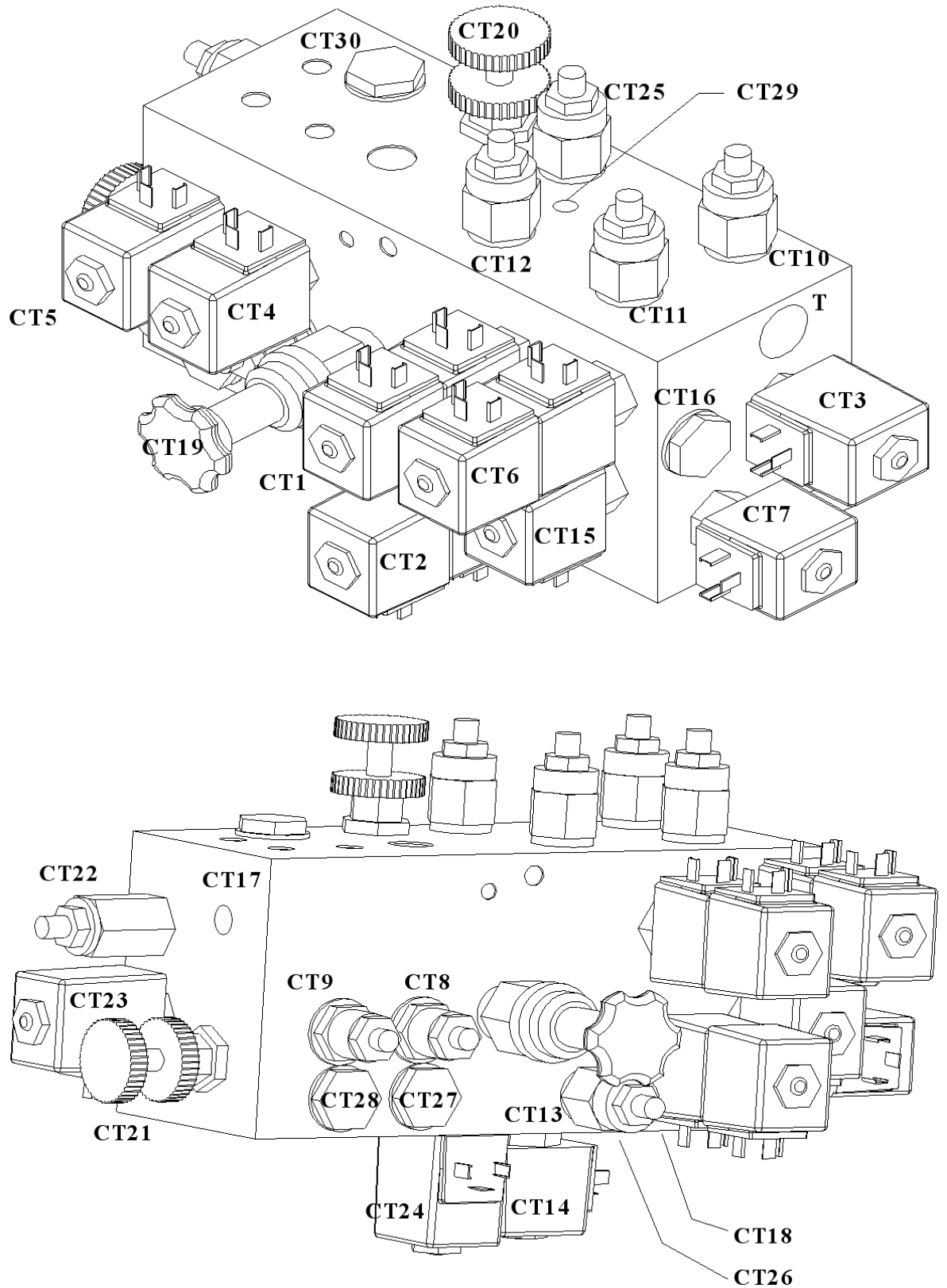

4.4 ELECTRICAL TROUBLESHOOTING TABLE

COMPONENT	FUNCTION															
	LOWER CONTROLS	UPPER CONTROLS	DRIVE FORWARD	DRIVE REVERSE	HIGH SPEED/CREEP	RAISE PLATFORM	LOWER PLATFORM	STEER LEFT	STEER RIGHT	DEPRESSION MECHANISM EXTEND	DEPRESSION MECHANISM RETRACT	BRAKES	TILT ALARM	DOWN ALARM	BATTERY CHARGE	
ALARM																
BATTERIES	X	X	X	X	X	X	X	X	X	X	X	X	X	X		
BATTERY CHARGER															X	
5 AMP CIRCUIT BREAKER	X	X	X	X	X	X	X	X	X	X	X	X	X	X		
175 AMP FUSE	X	X	X	X	X	X	X	X	X	X	X	X				
ECU	X	X	X	X	X	X	X	X	X	X	X	X	X	X		
MOTOR CONTROL	X	X	X	X	X	X	X	X	X	X	X	X				
MOTOR			X	X	X	X	X	X	X	X	X	X				
CHASSIS EMERGENCY STOP SWITCH	X	X	X	X	X	X	X	X	X	X	X	X	X	X		
CHASSIS KEY SWITCH	X	X	X	X	X	X	X	X	X	X	X	X	X	X		
PLATFORM EMERGENCY STOP SWITCH	X	X	X	X	X	X	X	X	X	X	X	X	X	X		
INTERLOCK SWITCH		X	X	X	X	X	X	X	X							
PQ CONTROL HANDLE		X	X	X		X	X									
HEIGHT LIMIT SWITCH						X										
PLATFORM STEERING SWITCH								X	X							
TILT SENSOR	X	X	X	X	X	X	X	X	X	X	X	X	X	X		
STEERING SOLENOID (RIGHT)									X							
STEERING SOLENOID (LEFT)								X								
PLATFORM LIFT SOLENOID						X										
DOWN SOLENOID							X									
REVERSE SOLENOID				X												
FORWARD SOLENOID			X													

4.5 FAULT CODES

INTRODUCTION

The MB20N-26 is equipped with a fault detection system.

If you have a faulty component, bad electrical connection or start up error a fault code will be displayed on the read out located on the upper control box.

For fault codes 01 - 39 the following procedure should be followed.

1. Ensure that no selector buttons are depressed.
2. Ensure that the deadman switch on the joystick is not held.
3. Ensure that the joystick is in neutral.
4. Ensure that the steer rocker is not activated.
5. Ensure that analog rocker is in neutral.

Then re-cycle power, do this by pushing and releasing the emergency stop button.

If the fault code is still displayed you may have a faulty upper or lower control box, consult the error code list to identify the problem component and replace if necessary.

For fault codes 51 - 68 the following procedure should be followed.

1. Check the fault code list to identify the problem component.
2. Ensure that the wiring harness is connected, secure, in good condition and fully intact.
3. Ensure that the problem component is receiving electrical signal, consult the schematics in section 6 of this manual to identify the ECU output and harness test points.
4. If no ECU output is present replace the ECU.
5. If ECU output is present but no signal is reaching the component replace the wiring harness.
6. If signal is reaching the component but the component is not functioning replace the component (refer to section 7 of this manual for part number information).

FAULT CODE SUMMARY:

- 01 - System initialization error
- 02 - System communication error
- 03 - System overload error

- 22 - Platform Left Turn Switch ON at power-up
- 23 - Platform Right Turn Switch ON at power-up
- 24 - Platform Rotate Lift Switch ON at power-up
- 25 - Platform High Speed Drive Switch ON at power-up
- 26 - Platform Mast Switch ON at power-up
- 27 - Platform Low Speed Drive Switch ON at power-up
- 28 - Platform Jib Switch ON at power-up
- 29 - Platform Joystick Enable Switch ON at power-up
- 31 - Platform Joystick not in neutral at power-up

- 32 - Lower Control Analog Rocker not in neutral at power-up
- 34 - Lower Control Rotate Lift Switch ON at power-up
- 36 - Lower Control Mast Switch ON at power-up
- 38 - Lower Control Jib Boom Switch ON at power-up
- 39 - Lower Control Enable Switch ON at power-up

- 51 - High Speed 1 Coil fault
- 52 - High Speed 2 Coil fault
- 53 - Pot Hole Extend Coil fault
- 54 - Pot Hole Retract Coil fault
- 55 - Mast Up Coil fault
- 56 - Mast Down Coil fault
- 57 - Slew Lift CW Coil fault
- 58 - Slew Lift CCW Coil fault
- 59 - Steer Right Coil fault
- 61 - Steer Left Coil fault
- 62 - Jib Up Coil fault
- 63 - Jib Down Coil fault
- 64 - Lift-Drive Coil fault
- 66 - Drive Forward Coil fault
- 67 - Drive Reverse Coil fault
- 68 - Low Battery fault

5. Schematics

INTRODUCTION

This section contains electrical and hydraulic schematics and associated information for maintenance and fault finding purposes.

CONTENTS

Hydraulic Schematic	5-2
Electrical Schematic	5-3
J1 Harness Schematic	5-4
J1 Harness Information	5-5
J1 Harness Assembly	5-6
J2 Harness Schematic	5-7
J2 Harness Information	5-8
J2 Harness Assembly	5-9

MB20N-26
Hydraulic System Schematic

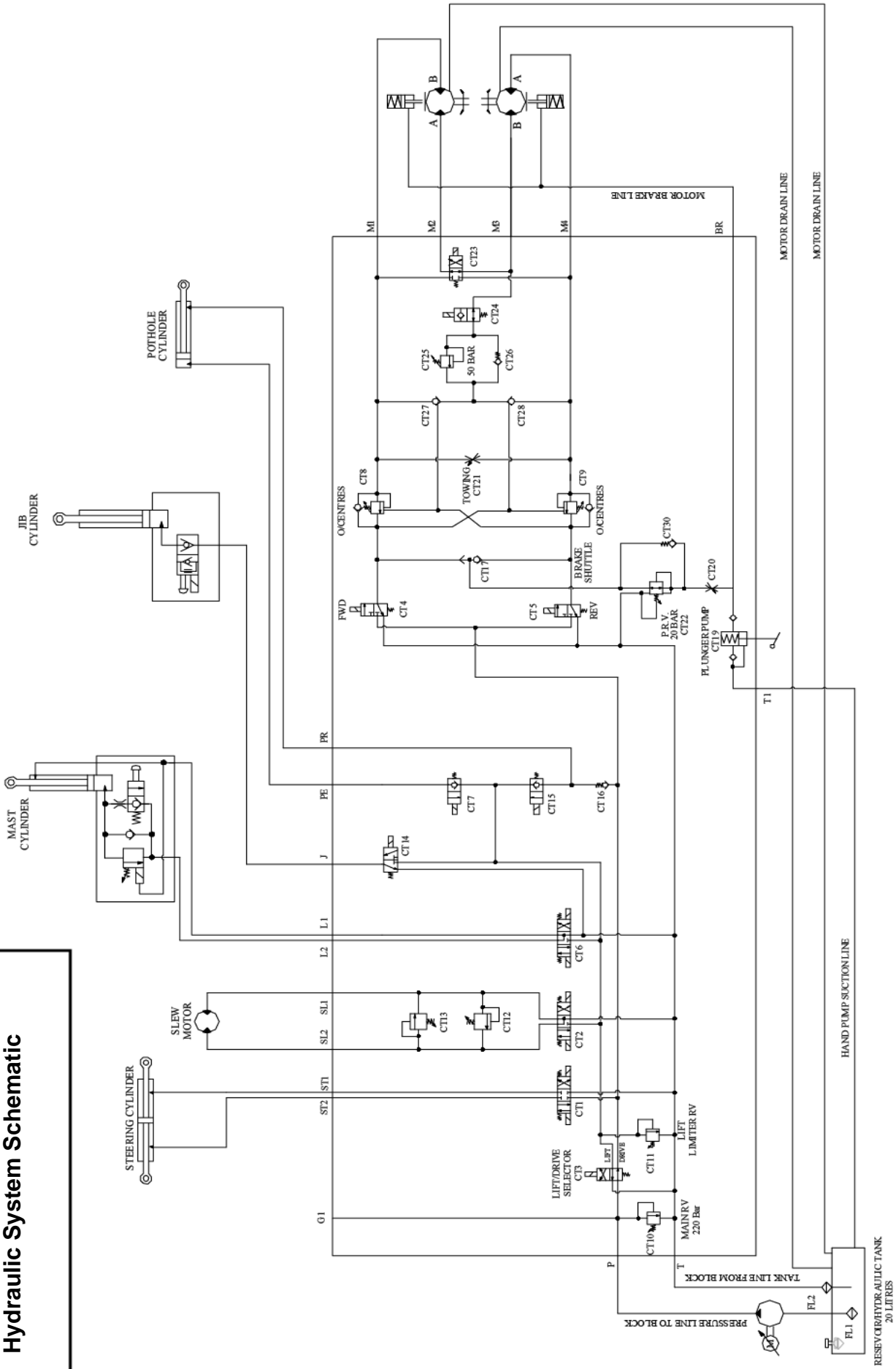

Electrical System Schematic

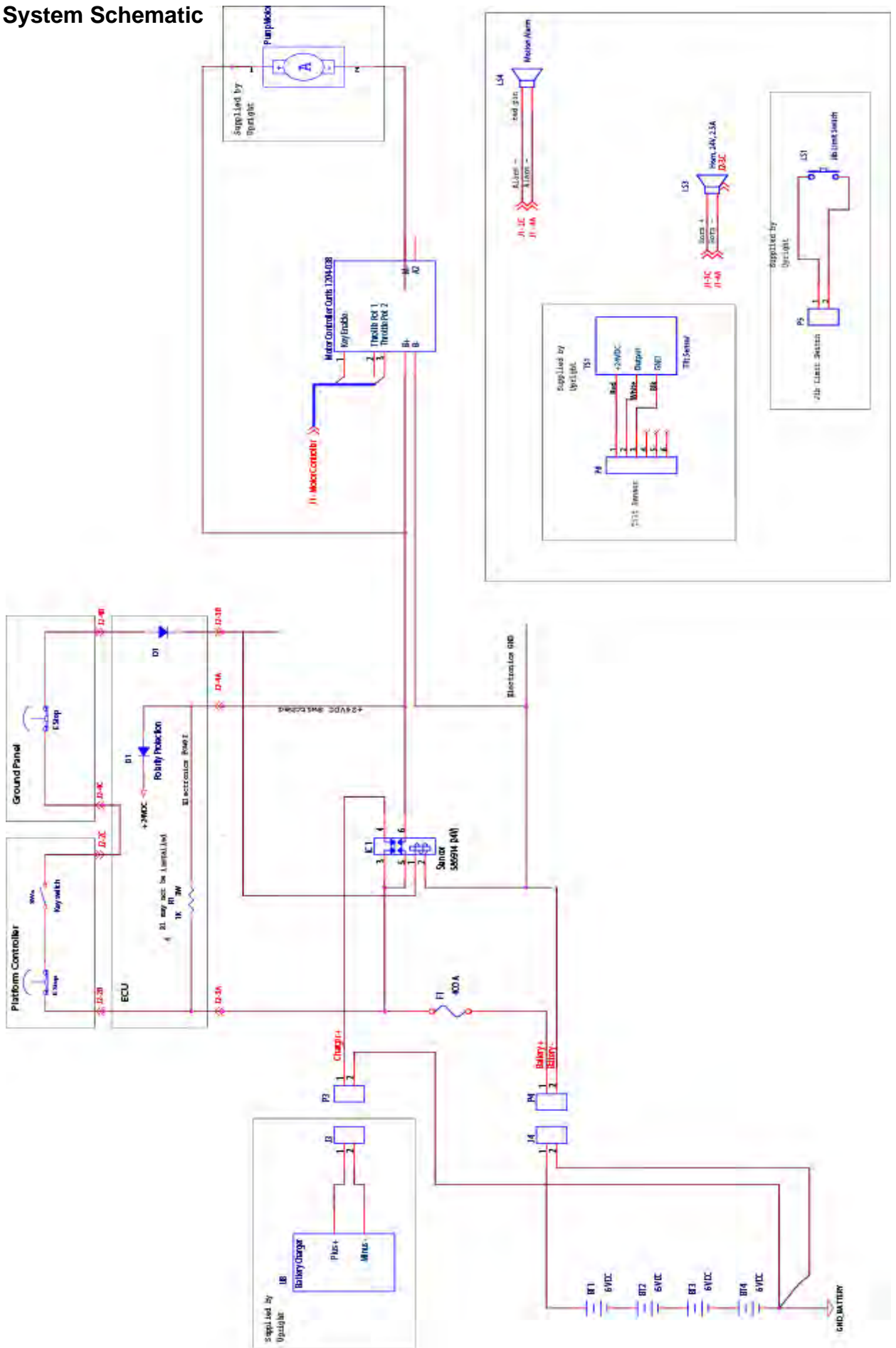

J1 Harness Schematic

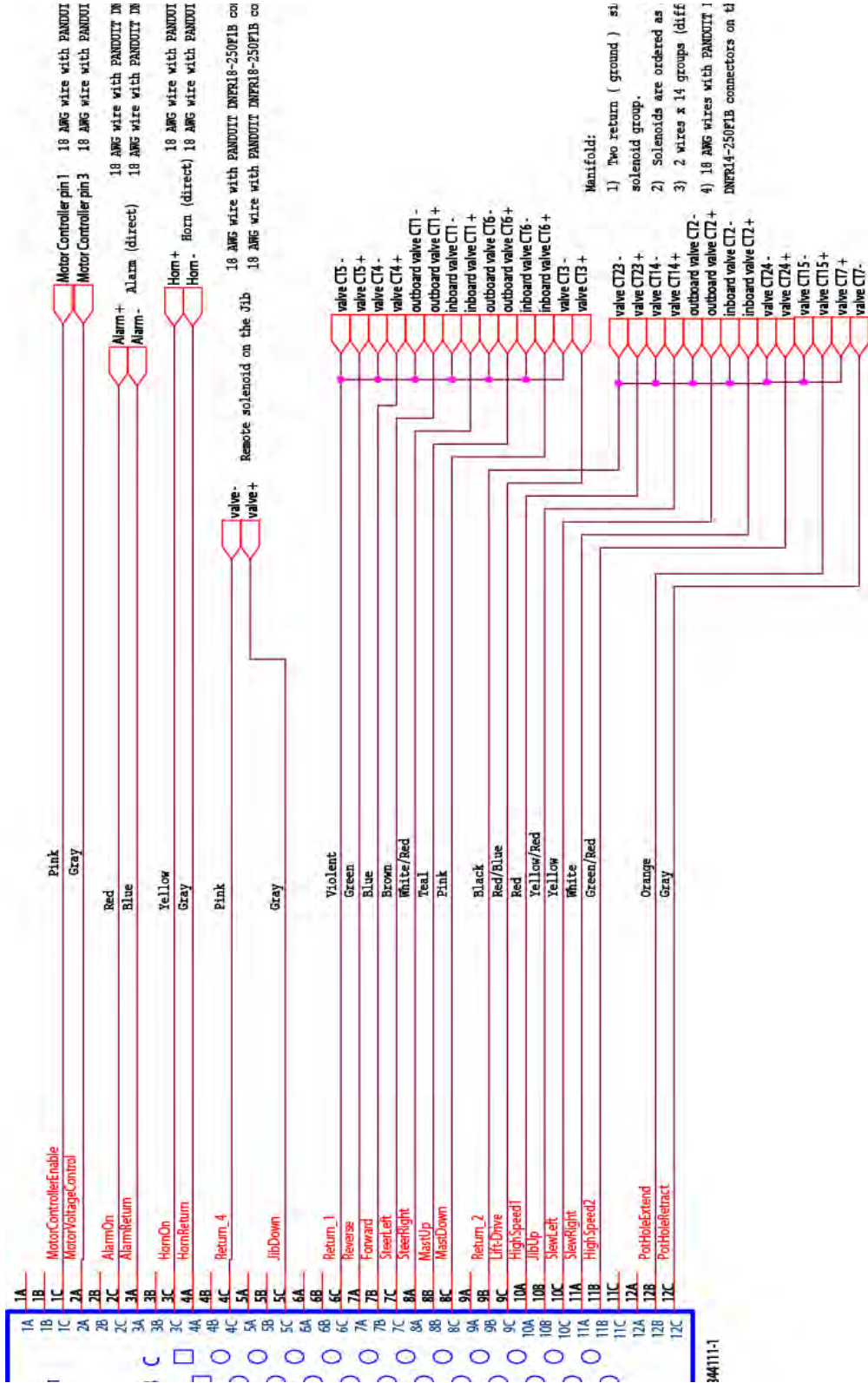

J1 Harness Information

WIRE INFORMATION														
ITEM NO.	POSITION	COLOR	GAUGE	LENGTH	ITEM NO.	POSITION	COLOR	GAUGE	LENGTH	ITEM NO.	POSITION	COLOR	GAUGE	LENGTH
1	A1		NOT USED		13	B1		NOT USED		25	C1	PINK	18	1524 (60.0")
2	A2	GRAY	18	1524 (60.0")	14	B2		NOT USED		26	C2	RED	18	254 (10.0")
3	A3	BLUE	18	254 (10.0")	15	B3		NOT USED		27	C3	YELLOW	18	344 (14.0")
4	A4	GRAY	18	344 (14.0")	16	B4		NOT USED		28	C4	PINK	18	1021 (402.0")
5	A5		NOT USED		17	B5		NOT USED		29	C5	GRAY	18	1021 (402.0")
6	A6		NOT USED		18	B6		NOT USED		30	C6	VIOLET	18	1117 (44.0")
7	A7	GREEN	18	1117 (44.0")	19	B7	BLUE	18	1168 (46.0")	31	C7	BROWN	18	1270 (50.0")
8	A8	WHITE/RED	18	1219 (48.0")	20	B8	LIGHT BLUE	18	1371 (54.0")	32	C8	PINK	18	1321 (52.0")
9	A9		NOT USED		21	B9	BLACK	18	1117 (44.0")	33	C9	RED/BLUE	18	1422 (56.0")
10	A10	RED	18	1117 (44.0")	22	B10	YELLOW/RED	18	1371 (54.0")	34	C10	YELLOW	18	1270 (50.0")
11	A11	WHITE	18	1219 (48.0")	23	B11	GREEN/RED	18	1193 (47.0")	35	C11		NOT USED	
12	A12		NOT USED		24	B12	ORANGE	18	1371 (54.0")	36	C12	GRAY	18	1422 (56.0")
JUMPER INFORMATION														
37	FROM C6	VIOLET	18	457 (18.0")	39	B9	BLACK	18	508 (20.0")					
38	FROM B9	BLACK	18	457 (18.0")										
TERMINAL INFORMATION														
40		FASTON PANDUIT DNF18-250F1B			42		FASTON PANDUIT DNF18-250F1B							
41		FASTON PANDUIT DNF14-250F1D												

J1 Harness Assembly

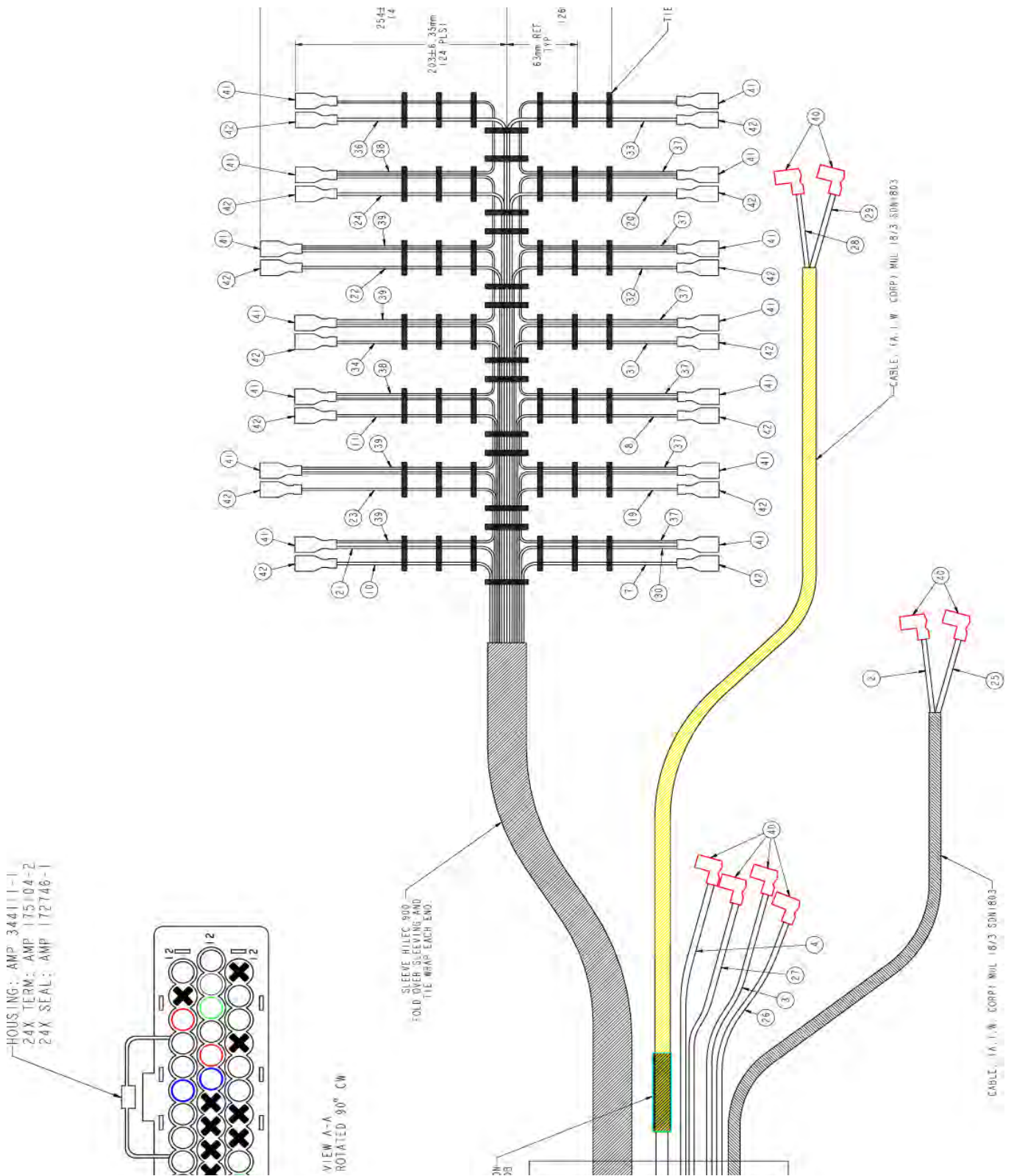

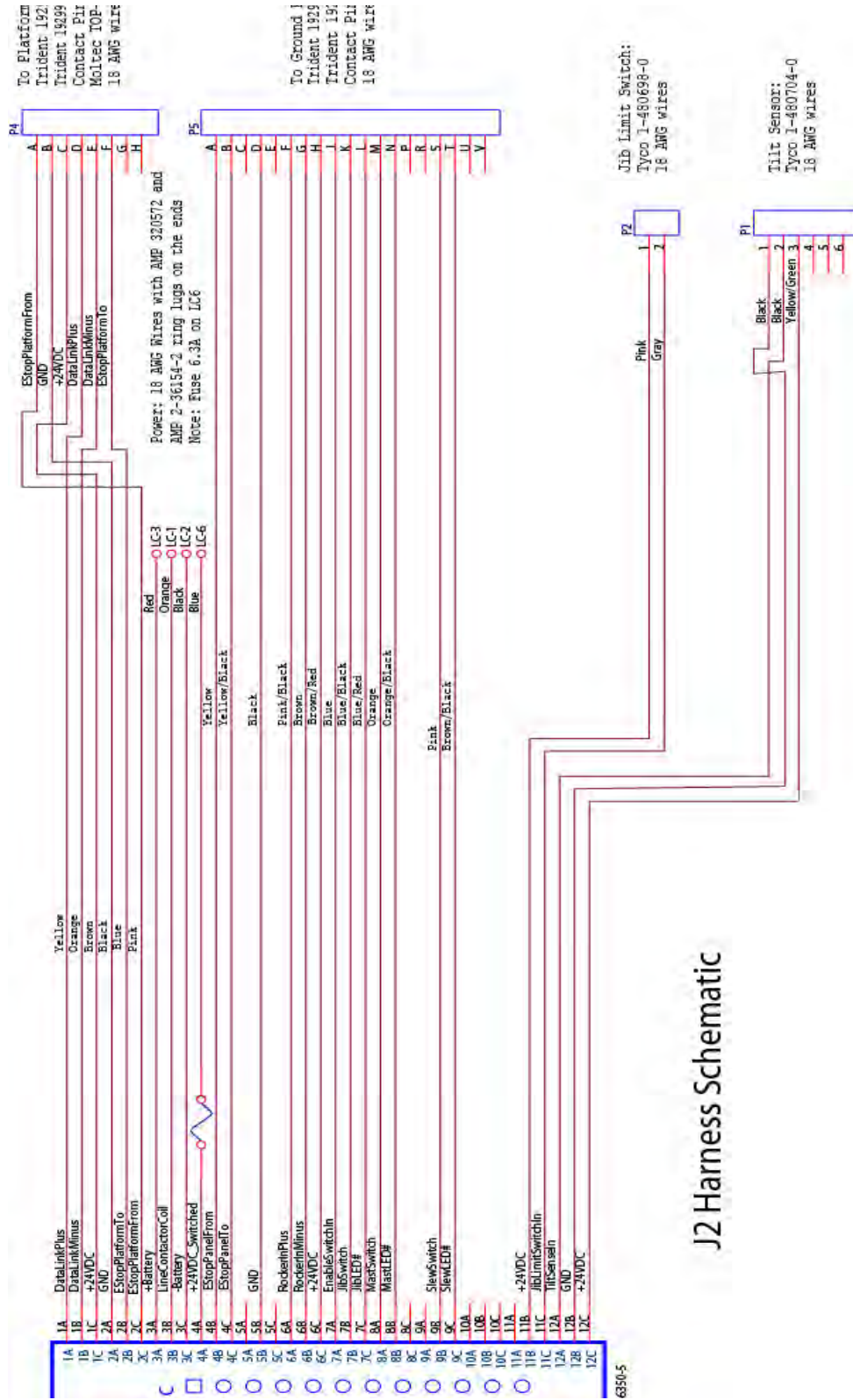

J2 Harness Schematic

J2 Harness Information

WIRE INFORMATION														
TABLE 1														
ITEM NO.	POSITION	COLOR	GAUGE	LENGTH	ITEM NO.	POSITION	COLOR	GAUGE	LENGTH	ITEM NO.	POSITION	COLOR	GAUGE	LENGTH
1	A1	YELLOW, FROM ITEM 85	18		13	B1	ORANGE, FROM ITEM 85	18		25	C1	BROWN, FROM ITEM 85	18	
2	A2	BLACK, FROM ITEM 85	18		14	B2	BLUE, FROM ITEM 85	18		26	C2	PINK, FROM ITEM 85	18	
3	A3	RED, SINGLE WIRE	18	1373 (54.0")	15	B3	ORANGE, SINGLE WIRE	18	1372 (54.0")	27	C3	BLACK, SINGLE WIRE	18	1372 (54.0")
4	A4	BLUE, SINGLE WIRE	18	1373 (54.0")	16	B4	YELLOW, FROM ITEM 86	18		28	C4	YELLOW/BLACK, FROM ITEM 86	18	
5	A5	NOT USED			17	B5	BLACK, FROM ITEM 86	18		29	C5	NOT USED		
6	A6	PINK/BLACK, FROM ITEM 86	18		18	B6	BROWN, FROM ITEM 86	18		30	C6	BROWN/RED, FROM ITEM 86	18	
7	A7	BLUE, FROM ITEM 86	18		19	B7	BLUE/BLACK, FROM ITEM 86	18		31	C7	BLUE/RED, FROM ITEM 86	18	
8	A8	ORANGE, FROM ITEM 86	18		20	B8	ORANGE/BLACK, FROM ITEM 86	18		32	C8	NOT USED		
9	A9	NOT USED			21	B9	PINK, FROM ITEM 86	18		33	C9	BROWN/BLACK, FROM ITEM 86	18	
10	A10	NOT USED			22	B10	NOT USED			34	C10	NOT USED		
11	A11	NOT USED			23	B11	PINK, PIN #1, FROM ITEM 87	18		35	C11	GREY, PIN #2, FROM ITEM 87	18	
12	A12	BLACK #2, FROM ITEM 88	18		24	B12	BLACK #1, FROM ITEM 88	18		36	C12	YEL/GRN #3, FROM ITEM 88	18	
TABLE 2 (UTILIZING CABLE ITEM NO. 86)														
37	A	SEE TABLE 1, ITEM 16			44	H	SEE TABLE 1, ITEM 30			51	R	NOT USED		
38	B	SEE TABLE 1, ITEM 28			45	J	SEE TABLE 1, ITEM 7			52	S	SEE TABLE 1, ITEM 21		
39	C	NOT USED			46	K	SEE TABLE 1, ITEM 19			53	T	SEE TABLE 1, ITEM 33		
40	D	SEE TABLE 1, ITEM 17			47	L	SEE TABLE 1, ITEM 31			54	U	NOT USED		
41	E	NOT USED			48	M	SEE TABLE 1, ITEM 8			55	V	NOT USED		
42	F	SEE TABLE 1, ITEM 6			49	N	SEE TABLE 1, ITEM 20							
43	G	SEE TABLE 1, ITEM 18			50	P	NOT USED							
TABLE 3 (UTILIZING CABLE ITEM NO. 85)														
56	A	SEE TABLE 1, ITEM 26			59	D	SEE TABLE 1, ITEM 1			62	G	NOT USED		
57	B	SEE TABLE 1, ITEM 2			60	E	SEE TABLE 1, ITEM 13			63	H	NOT USED		
58	C	SEE TABLE 1, ITEM 25			61	F	SEE TABLE 1, ITEM 14							
TABLE 4 (UTILIZING CABLE ITEM NO. 88)														
64	1	SEE TABLE 1, ITEM 24			66	3	SEE TABLE 1, ITEM 36			68	5	NOT USED		
65	2	SEE TABLE 1, ITEM 12			67	4	NOT USED			69	6	NOT USED		
TERMINAL INFORMATION														
70		HOUSING, AMP, P/N 346189-5, RED			75		TERMINAL, AMP, P/N 2-36154-2 (2 REQ'D)			80		CONNECTOR, ITT, P/N 192926-0510		
71		TERMINAL, AMP, P/N 175104-2 (28 REQ'D)			76		HOUSING, AMP, P/N 1-480704-0			81		TERMINAL, ITT, P/N 92900-0408 OR 192900-0450 (6 REQ'D)		
72		SEAL, AMP, P/N 172746-1 (28 REQ'D)			77		TERMINAL, AMP, P/N 350218-1 (5 REQ'D)			82		CABLE CLAMP, ITT, 192990-1560		
73		HOUSING, AMP, P/N 1-480698-0			78		CONNECTOR, ITT, P/N 192926-0530			83		CABLE CLAMP, MOLTEC, BSTP-11		
74		TERMINAL, AMP, P/N 320572 (2 REQ'D)			79		TERMINAL, ITT, P/N 192900-0408 OR 192900-0450 (15 REQ'D)			84		BARREL ONLY FROM ITT, 192990-1540		
CABLE INFORMATION														
85		CABLE, (A.I.W. CORP) MUL 18-6 SDN1806			87		CABLE, (A.I.W. CORP) MUL 18/3 SDN1803			89				
86		CABLE, (A.I.W. CORP) MUL18/16 SDN1816			88		CABLE, OFLEX, MUL 18/3 601803							

J2 Harness Assembly

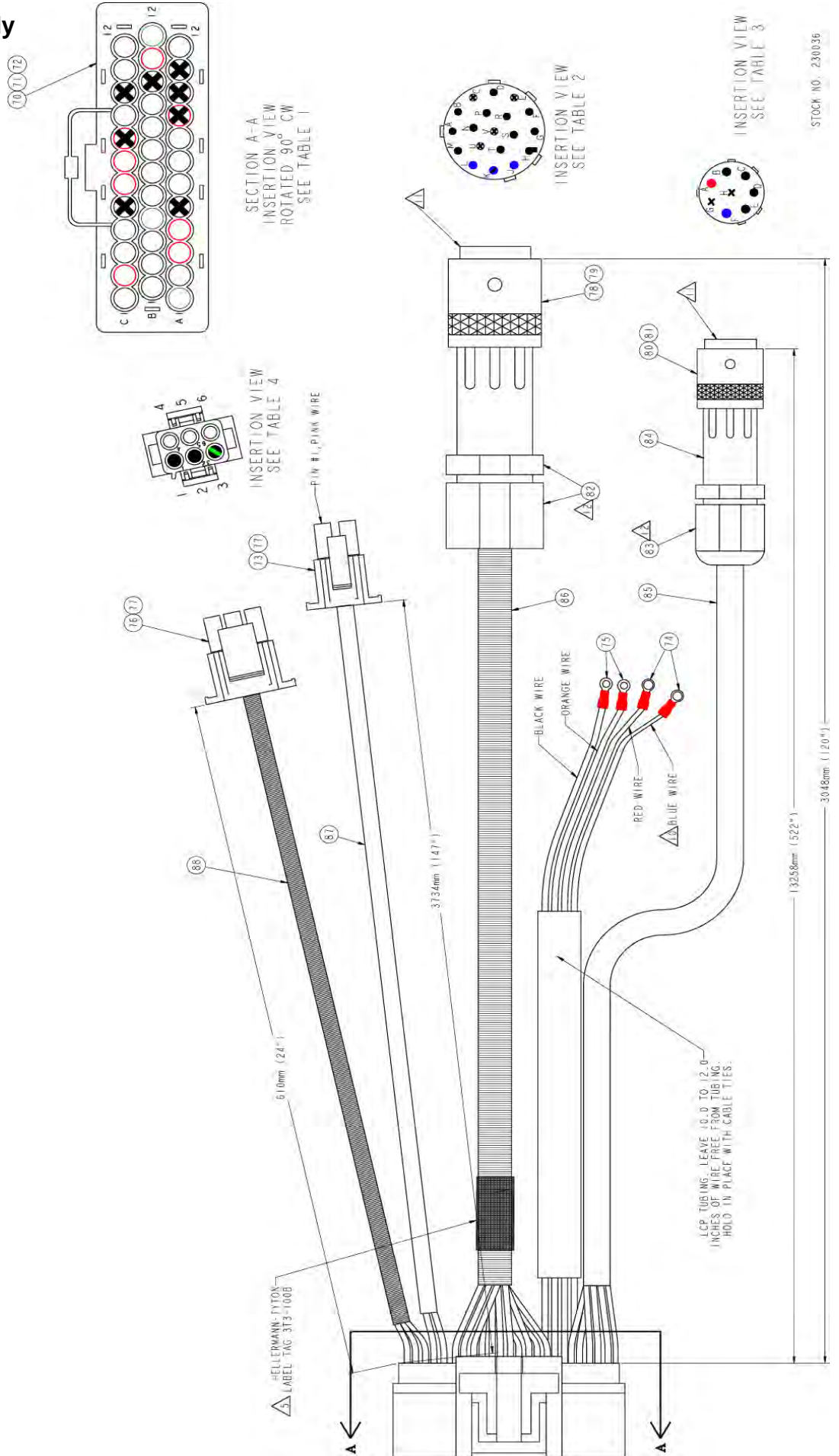

STOCK NO. 230036

6. Illustrated Parts List

FINAL ASSEMBLY

MB20N & MB26

GENERAL PARTS INDEX

Chassis Assembly _____	2
Hydraulic Tank _____	4
Hydraulic Pump-Motor Unit _____	5
Slew Bearing _____	6
Steering Assembly _____	7
Pothole Assembly _____	9
Wheel Assembly _____	11
Mast Assembly _____	13
Wear Pad Kit _____	15
Mast Sub-Assembly _____	17
Chain Group _____	18
Sequence Straps _____	21
Main Lift Cylinder _____	22
Jib Assembly (including Overload) _____	24
Control Panel _____	27
ECU Assembly 501243-003 _____	29
Electrical System Layout _____	30
Hydraulic Valve Manifold 501471-000 _____	31
Hydraulic Component Assembly _____	32
Water Fill System & Top-Up System (501652-000) _____	34
Covers _____	35
Decals _____	36

NOTE: Warranty is void if ballast is removed from the machine.

NOTE: When selecting parts/part-numbers it is necessary to first identify the machine type in question, i.e.

- MB20N
- MB26

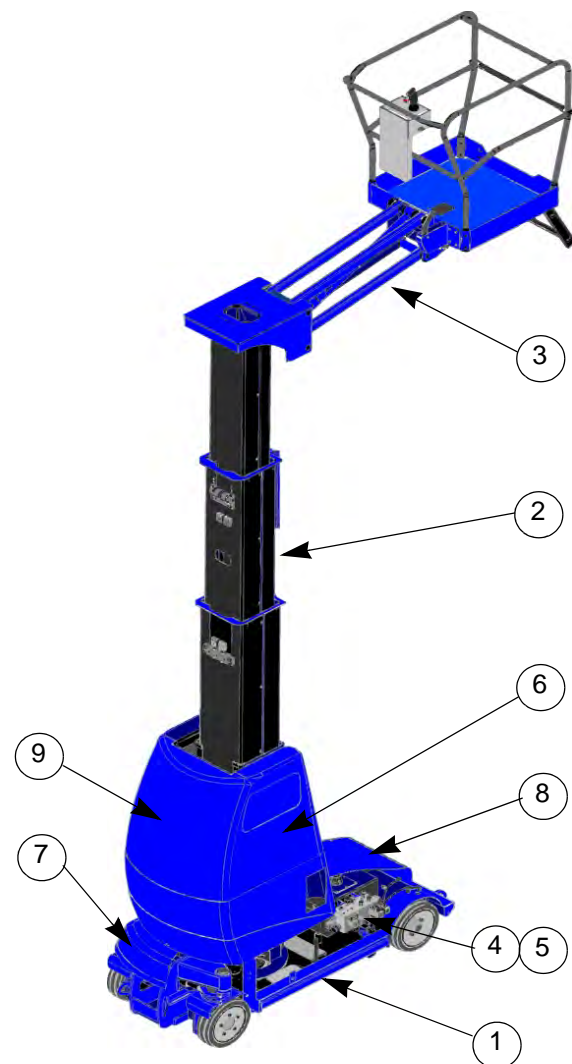

ITEM	DESCRIPTION
1	Chassis Assembly
2	Mast Assembly
3	Jib & Cage Assembly
4	Electrical Assembly
5	Hydraulic Assembly
6	Decal Assembly
7	Front Chassis Cover
8	Rear Chassis Cover
9	Mast/Ballast Cove

CHASSIS ASSEMBLY MB20N

ITEM	PART No.	DESCRIPTION	QTY.
1	500715-000	Chassis Weldment	1
2	REF	Front Wheel Assembly	1
3	REF	Steering Assembly	1
4	REF	Pothole Assembly	1
5	500840-002	Chain Side Plate - LH	1
6	REF	Hydraulic Assembly	1
7	REF	Rear Wheel Assembly	1
8	501599-000	Pump/Motor Unit	1
9	501234-000	Hydraulic Tank	1
10	REF	Electrical Assembly	1
11	500840-001	Chain Side Plate - RH	1
12	REF	Slew Bearing Assembly	1
13	501212-000	Chassis Energy Chain	1
14	501290-000	Nose Cover	1

Note: Referenced assembly parts breakdown on following pages.

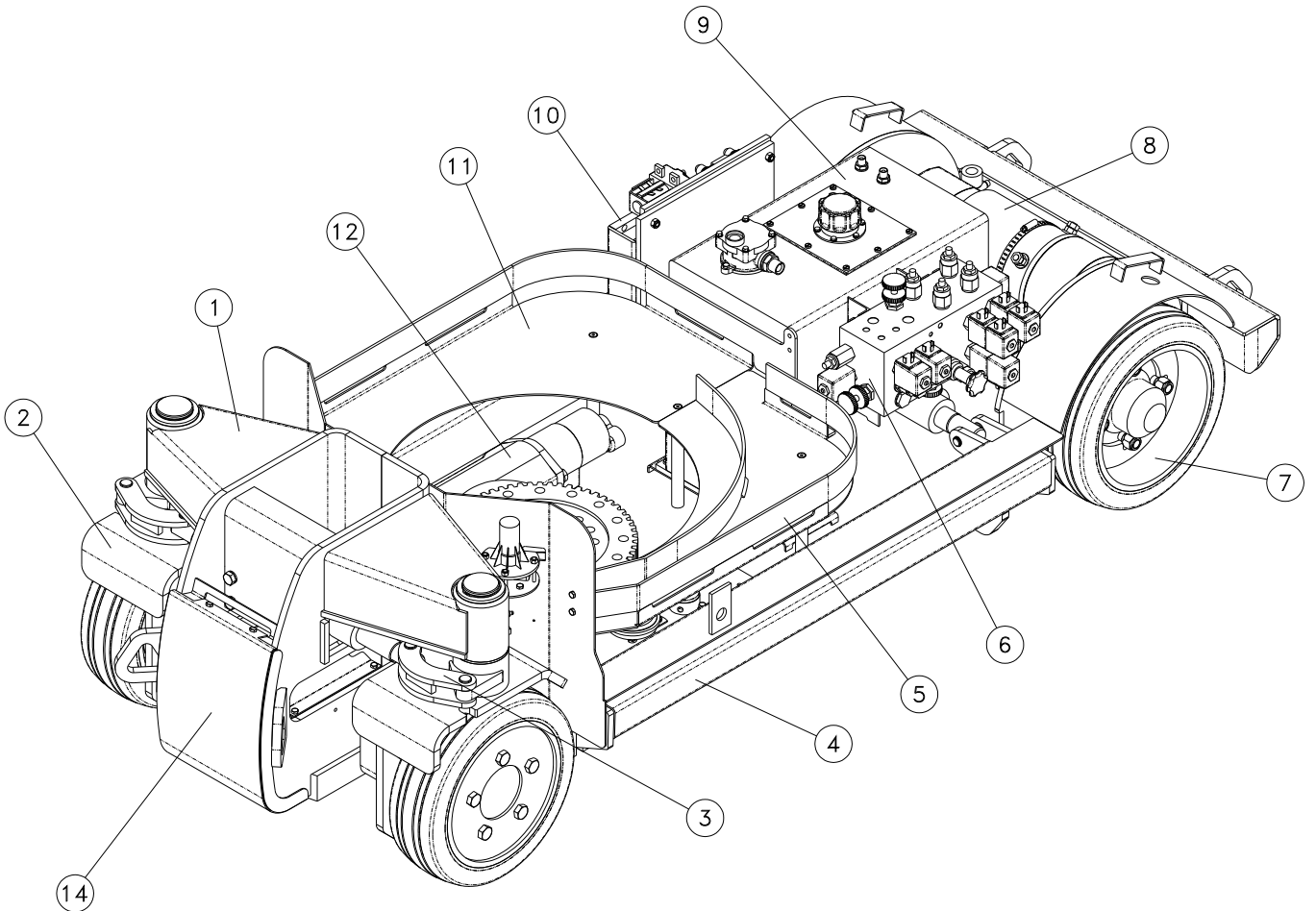

CHASSIS ASSEMBLY MB26

ITEM	PART No.	DESCRIPTION	QTY.
1	500715-001	Chassis Weldment	1
2	REF	Front Wheel Assembly	1
3	REF	Steering Assembly	1
4	REF	Pothole Assembly	1
5	500840-002	Chain Side Plate - LH	1
6	REF	Hydraulic Assembly	1
7	REF	Rear Wheel Assembly	1
8	501599-000	Pump/Motor Unit	1
9	501234-000	Hydraulic Tank	1
10	REF	Electrical Assembly	1
11	500840-001	Chain Side Plate - RH	1
12	REF	Slew Bearing Assembly	1
13	501212-000	Chassis Energy Chain	1
14	501290-001	Nose Cover	1

Note: Referenced assembly parts breakdown on following pages.

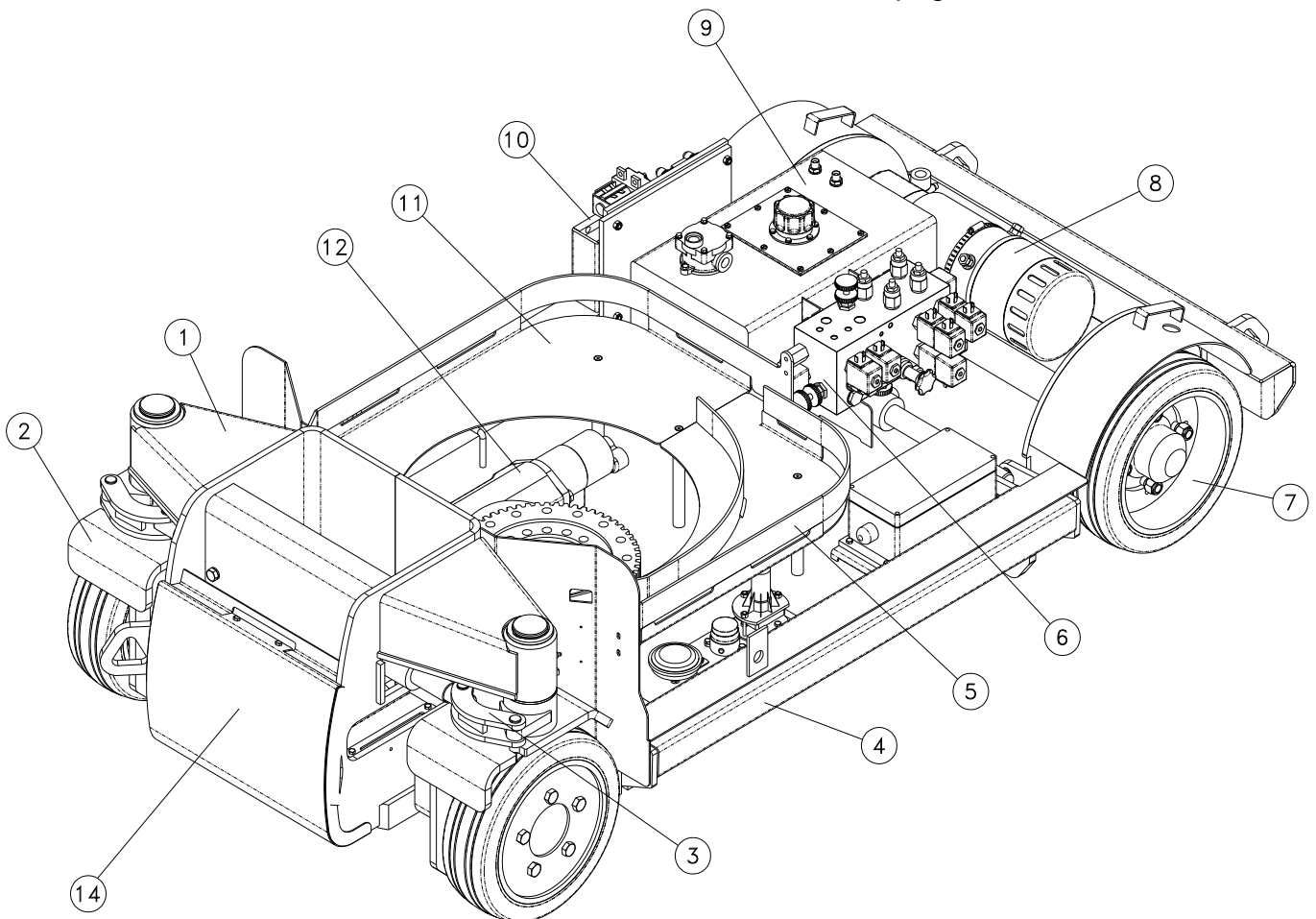

HYDRAULIC TANK

ITEM	PART No.	DESCRIPTION	QTY.
1	500728-000	Tank Weldment	1
2	500728-001	Inspection Lid & Gasket	1
3	057534-000	Filler Breather Cap	1
4	057532-000	Filter Body	1
5	058074-000	Filter Cartridge	1
6	057108-000	Drain Plug	1
7	057533-000	Hydraulic Oil ISO VG46	20 l.
8	058359-000	Suction Filter	1

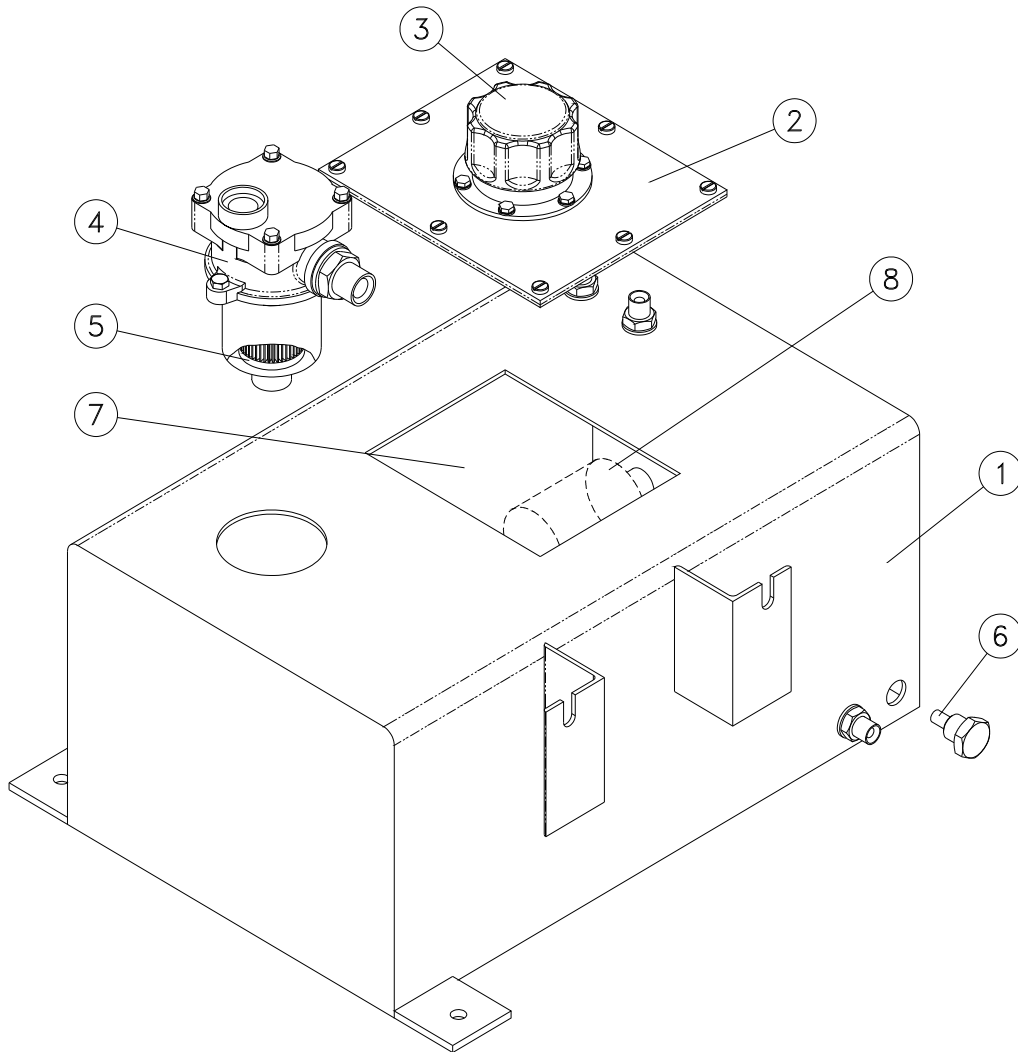

HYDRAULIC PUMP-MOTOR UNIT

ITEM	PART No.	DESCRIPTION	QTY.
1	501599-001	Electric Motor	1
2	058862-000	Hydraulic Pump Complete	1
3	058862-001	Pump Seal Kit	1
4	058847-000	Drive Coupling	1
5	501232-002	Pressure Port Adaptor Kit	1
6	501232-003	Suction Port Adaptor Kit	1
7	058114-000	Fixing Clip (Hose Clip)	1
	501757-000	Brushes (not shown)	1

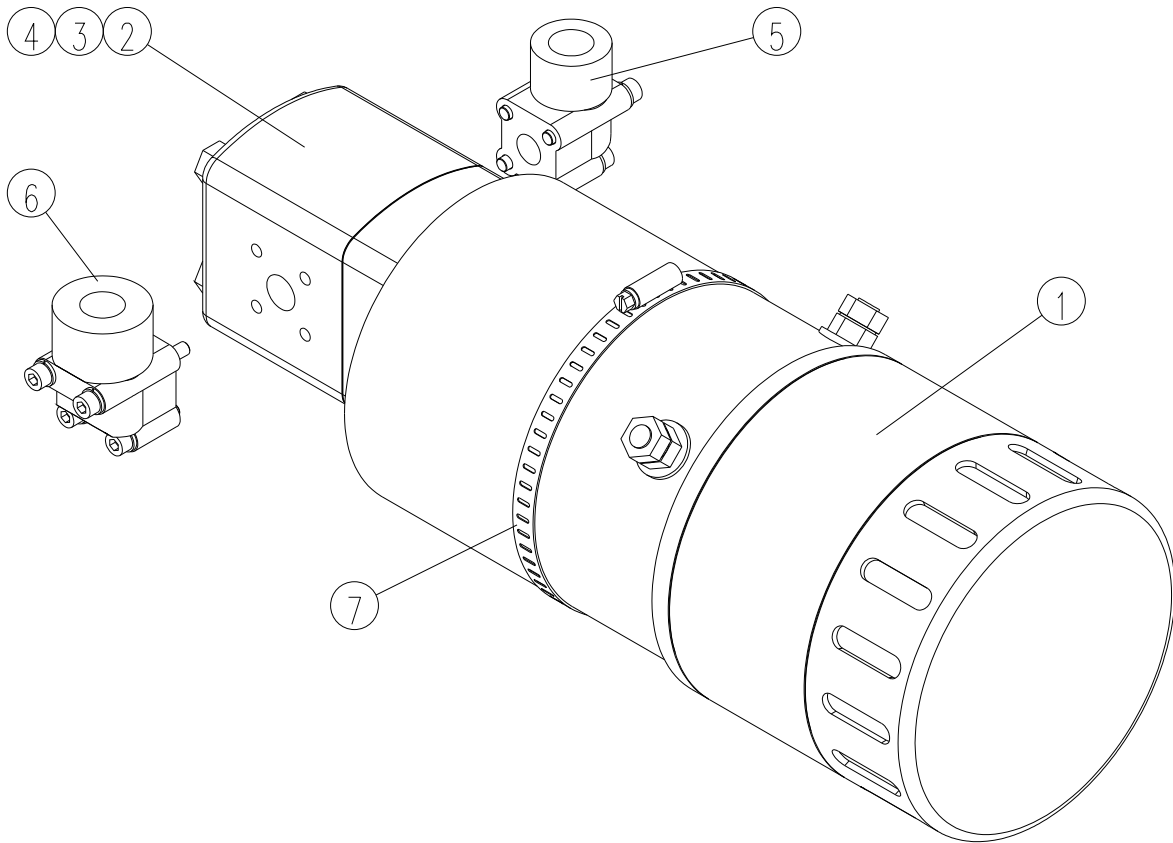

SLEW BEARING

ITEM	PART No.	DESCRIPTION	QTY
1	500284-000	Worm Drive Unit	1
2	500285-000	Hydraulic Motor	1
3	058480-070	Bolt, M16 x 70mm	16
4	058480-100	Bolt, M16 x 100mm	16
5	500281-000	Washer	32

Item 3 secures slewing ring to the mast assembly

Item 4 secures slewing ring to the chassis

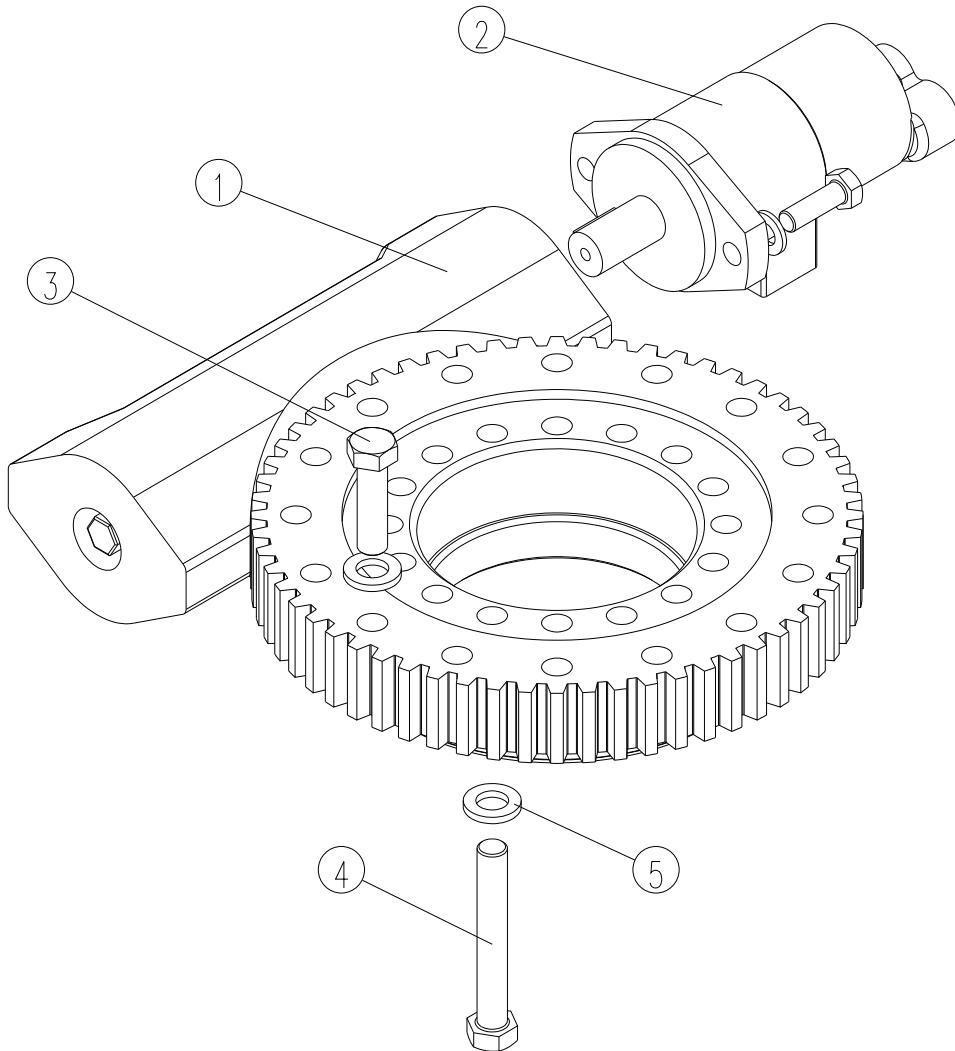

STEERING ASSEMBLY

MB20N

ITEM	PART NO.	DESCRIPTION	QTY.
1	500782-000	Steering Cylinder	1
2	501340-000	Flanged Bush (FMB 1509DU)	4
3	501227-000	Pivot Pin	4
4	500727-000	Link Arm Weldment	1
5	501056-000	Circlip (15mm External)	4
6	501439-000	Bush (MB1512DU)	2
7	058494-025	Hex Hd Screw M12 x 25	4
8	056021-012	Spring Washer M12	4
9	501067-000	Flanged Bush	2
10	056069-012	Flat Washer M12	4

MB26

ITEM	PART NO.	DESCRIPTION	QTY.
1	500782-001	Steering Cylinder	1
2	501340-000	Flanged Bush (FMB 1509DU)	4
3	501227-000	Pivot Pin	4
4	500727-000	Link Arm Weldment	1
5	501056-000	Circlip (15mm External)	4
6	501439-000	Bush (MB1512DU)	2
7	058494-025	Hex Hd Screw M12 x 25	4
8	056021-012	Spring Washer M12	4
9	501067-000	Flanged Bush	2
10	056069-012	Flat Washer M12	4

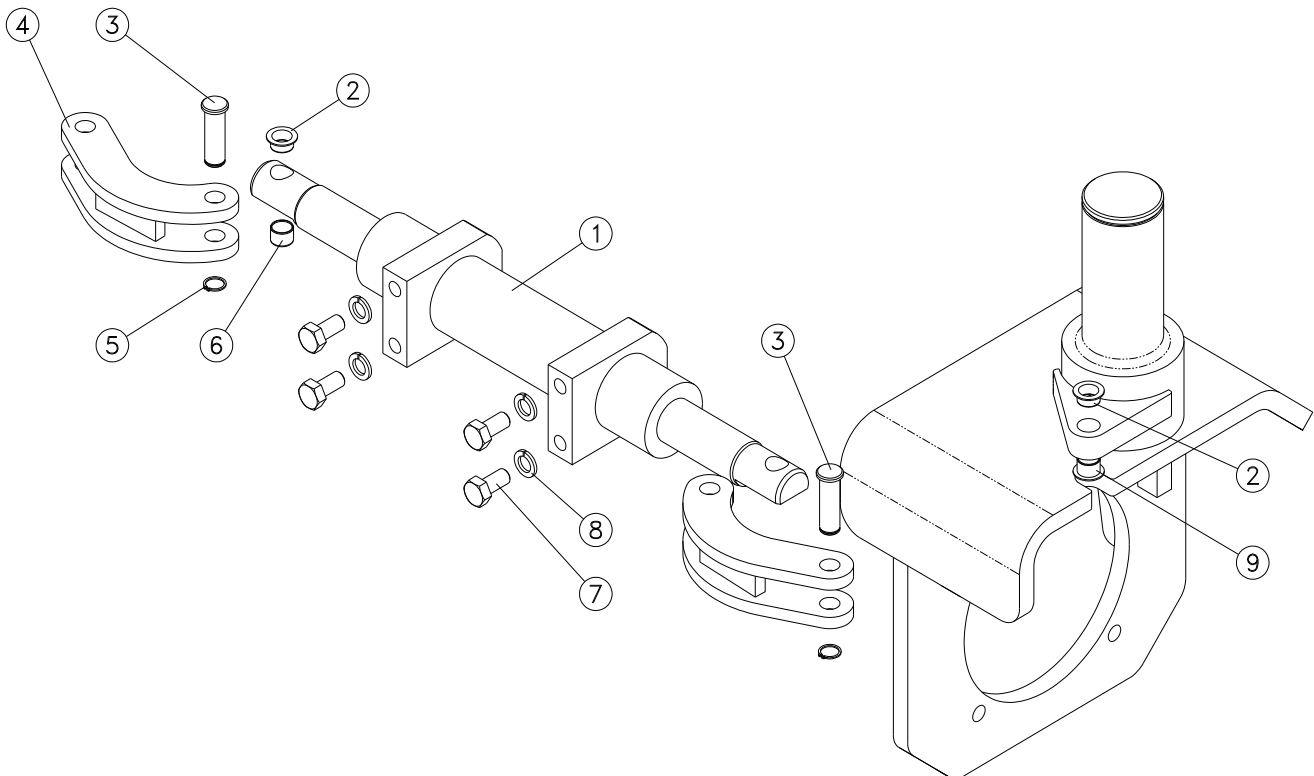

STEERING CYLINDER

MB20N

500782-000

MB26

500782-001

ITEM	PART NO.	DESCRIPTION	QTY.
1		Cylinder Body	1
2		Washer Tab	2
3		Body End Cap	2
4	500460-000	Seal Kit	1
5		Cylinder Rod	1

ITEM	PART NO.	DESCRIPTION	QTY.
1		Cylinder Body	1
2		Washer Tab	2
3		Body End Cap	2
4	500460-000	Seal Kit	1
5		Cylinder Rod	1

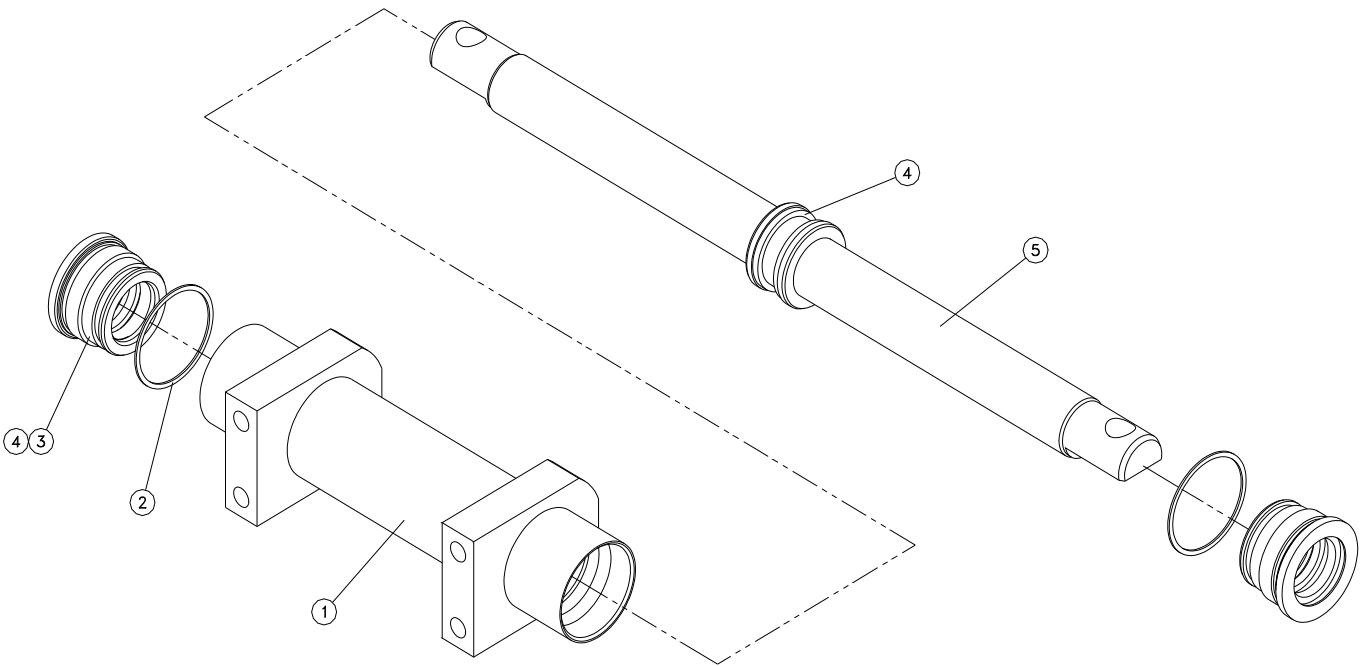

POTHOLE ASSEMBLY

MB20N

MB26

ITEM	PART No.	DESCRIPTION	QTY.
1	500726-002	Pothole Weldment - LH	1
2	500726-003	Pothole Weldment - RH	1
3	500783-000	Pothole Cylinder	1
4	501056-000	Circlip	2
5	501226-001	Pivot Pin	2
6	501067-000	Flanged Bush (FMB 1512 DU)	8
7	501570-000	Pivot Pin	4
8	058492-012	Hex Hd Screw M8 x 12	4
9	5000776-000	Retaining Plate	4

ITEM	PART No.	DESCRIPTION	QTY.
1	500726-002	Pothole Weldment - LH	1
2	500726-003	Pothole Weldment - RH	1
3	500783-001	Pothole Cylinder	1
4	501056-000	Circlip	2
5	501226-001	Pivot Pin	2
6	501067-000	Flanged Bush (FMB 1512 DU)	8
7	501570-000	Pivot Pin	4
8	058492-012	Hex Hd Screw M8 x 12	4
9	5000776-000	Retaining Plate	4

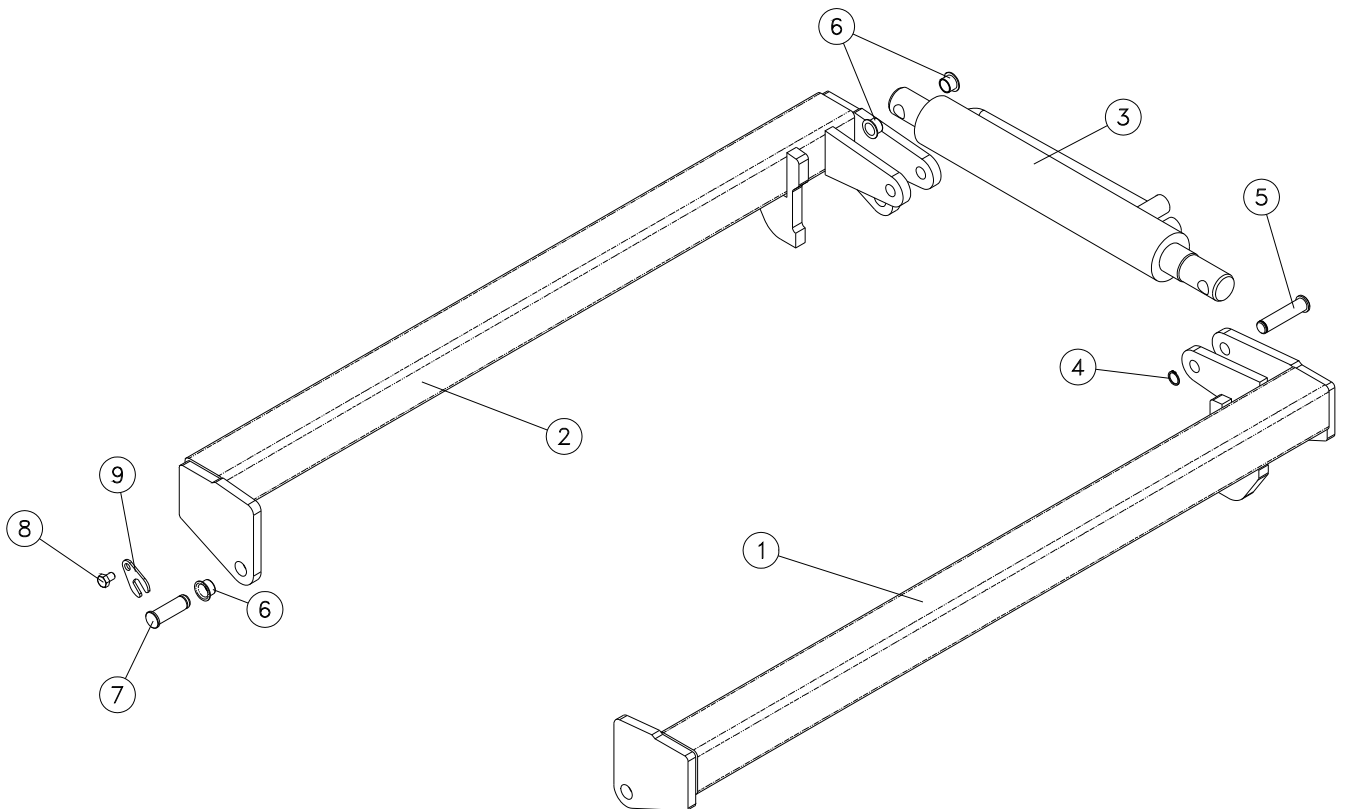

POTHOLE CYLINDER

MB20N - 500783-000

MB26 - 500783-001

ITEM	PART NO.	DESCRIPTION	QTY.
1		Cylinder Body	1
2		Washer Tab	1
3		Body End Cap	1
4	500459-000	Seal Kit	1
5		Cylinder Rod	1
6		Piston Head	1
7		Locknut	1
8		Washer	1
9		Circlip	1
10	057048-000	Grease Nipple M6	2

ITEM	PART NO.	DESCRIPTION	QTY.
1		Cylinder Body	1
2		Washer Tab	1
3		Body End Cap	1
4	500459-000	Seal Kit	1
5		Cylinder Rod	1
6		Piston Head	1
7		Locknut	1
8		Washer	1
9		Circlip	1
10	057048-000	Grease Nipple M6	2

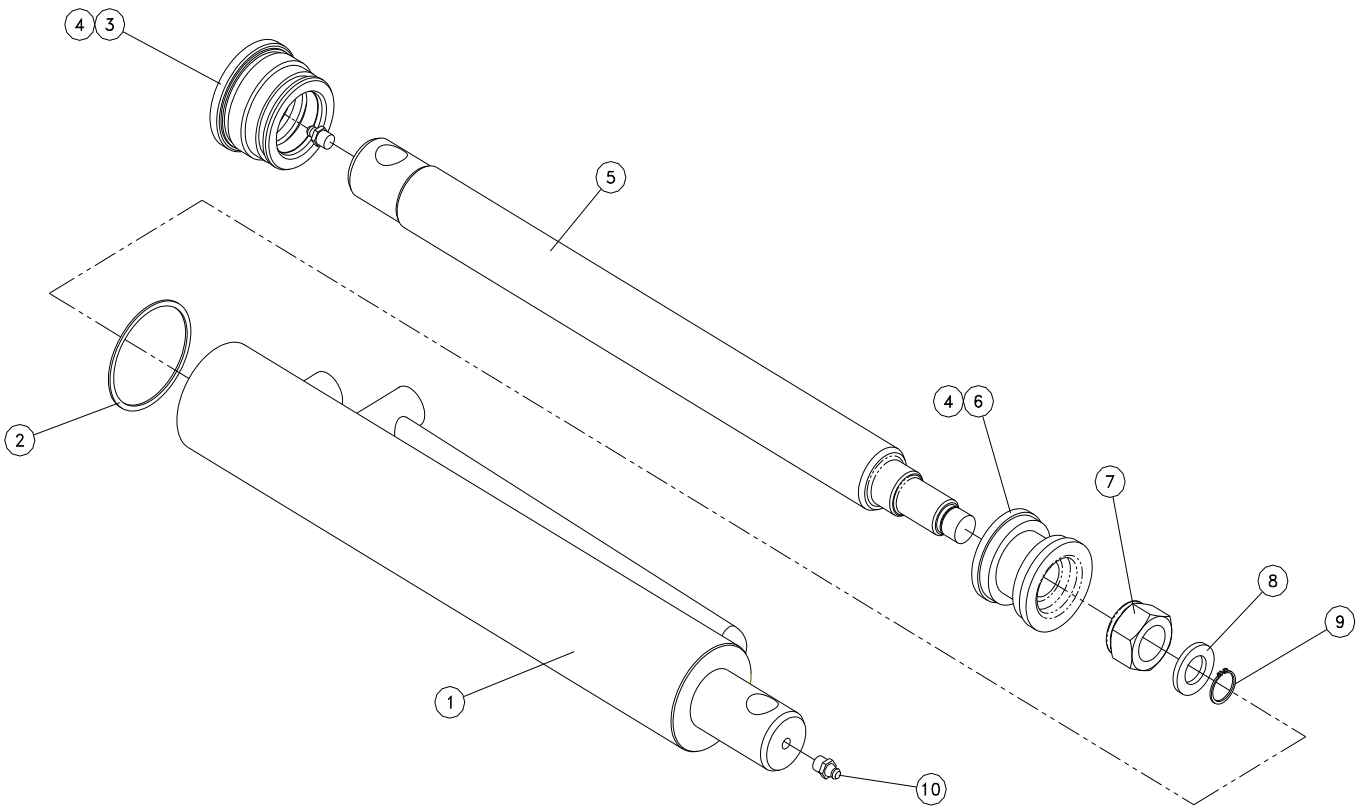

FRONT WHEEL ASSEMBLY

LEFT HAND

Item	Part No.	Description	Qty
1	501625-000	Front Wheel	1
2	501233-000	Wheel Motor	1
3	501430-000	Straight Swivel Fitting	1
4	501068-001	Swivel Fitting - Long	1
5	501066-000	Thrust Washer	1
6	501068-000	King Pin Bush	2
7	500775-000	Steering Retaining Washer	1
8	501055-000	Circlip	1
9	056065-040	Hex Hd Bolt M12 x 40	4
10	056021-012	Spring Washer M12	4
11	500730-000	Motor Mount Weldment	1
12	501268-000	Swivel Fitting - Short	1
13	501248-025	Hex Hd Screw M14 x 25	5

RIGHT HAND

Item	Part No.	Description	Qty
1	501625-000	Front Wheel	1
2	501233-001	Wheel Motor	1
3	501430-000	Straight Swivel Fitting	1
4	501068-001	Swivel Fitting - Long	1
5	501066-000	Thrust Washer	1
6	501068-000	King Pin Bush	2
7	500775-000	Steering Retaining Washer	1
8	501055-000	Circlip	1
9	056065-040	Hex Hd Bolt M12 x 40	4
10	056021-012	Spring Washer M12	4
11	500730-001	Motor Mount Weldment	1
12	501268-000	Swivel Fitting - Short	1
13	501248-025	Hex Hd Screw M14 x 25	5

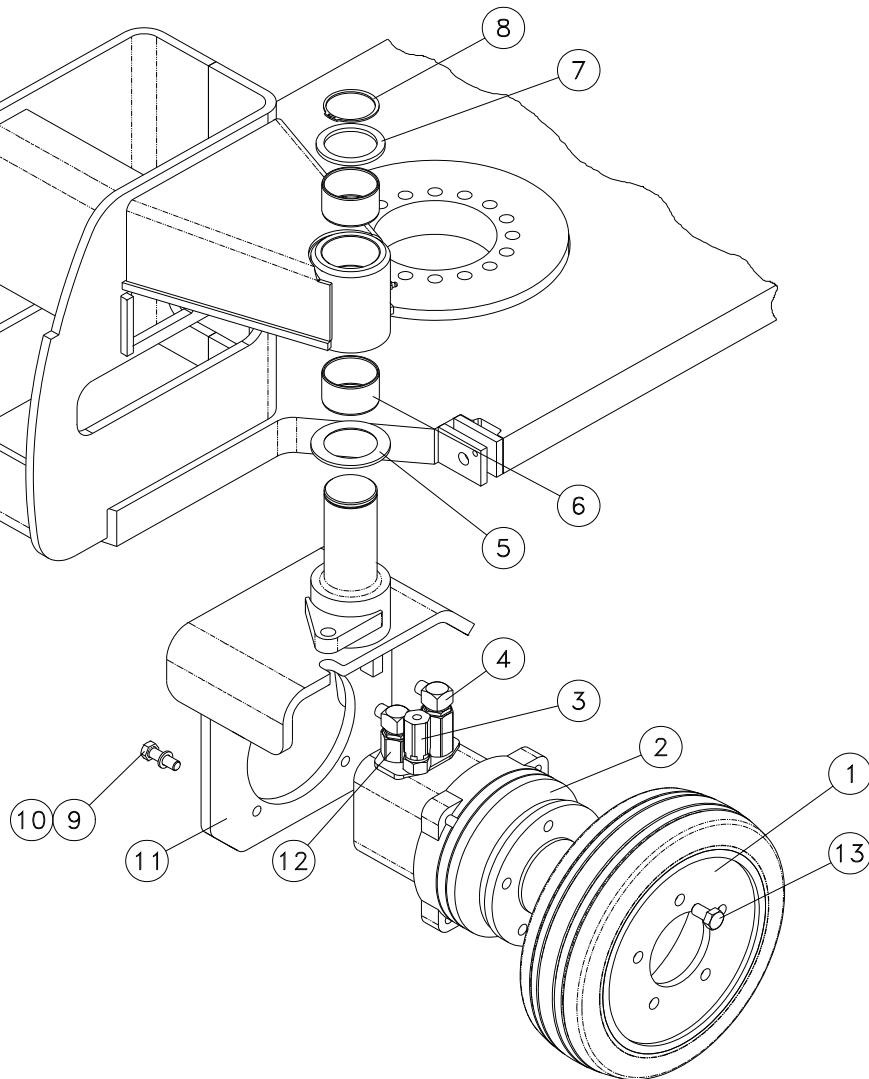

REAR WHEEL ASSEMBLY

Item	Part No.	Description	Qty.
1		Not a Serviceable Part	
2	501577-000	Roll Pin	2
3	501657-000	Oil Seal	2
4	REF	Bearing	2
5	REF	Wheel Hub	2
6	056069-030	Washer	2
7	501366-000	Castle Nut	2
8	501658-000	Hub Cap	2
9	501625-001	Rear Wheel	2
10	500790-002	Wheel Nut	8

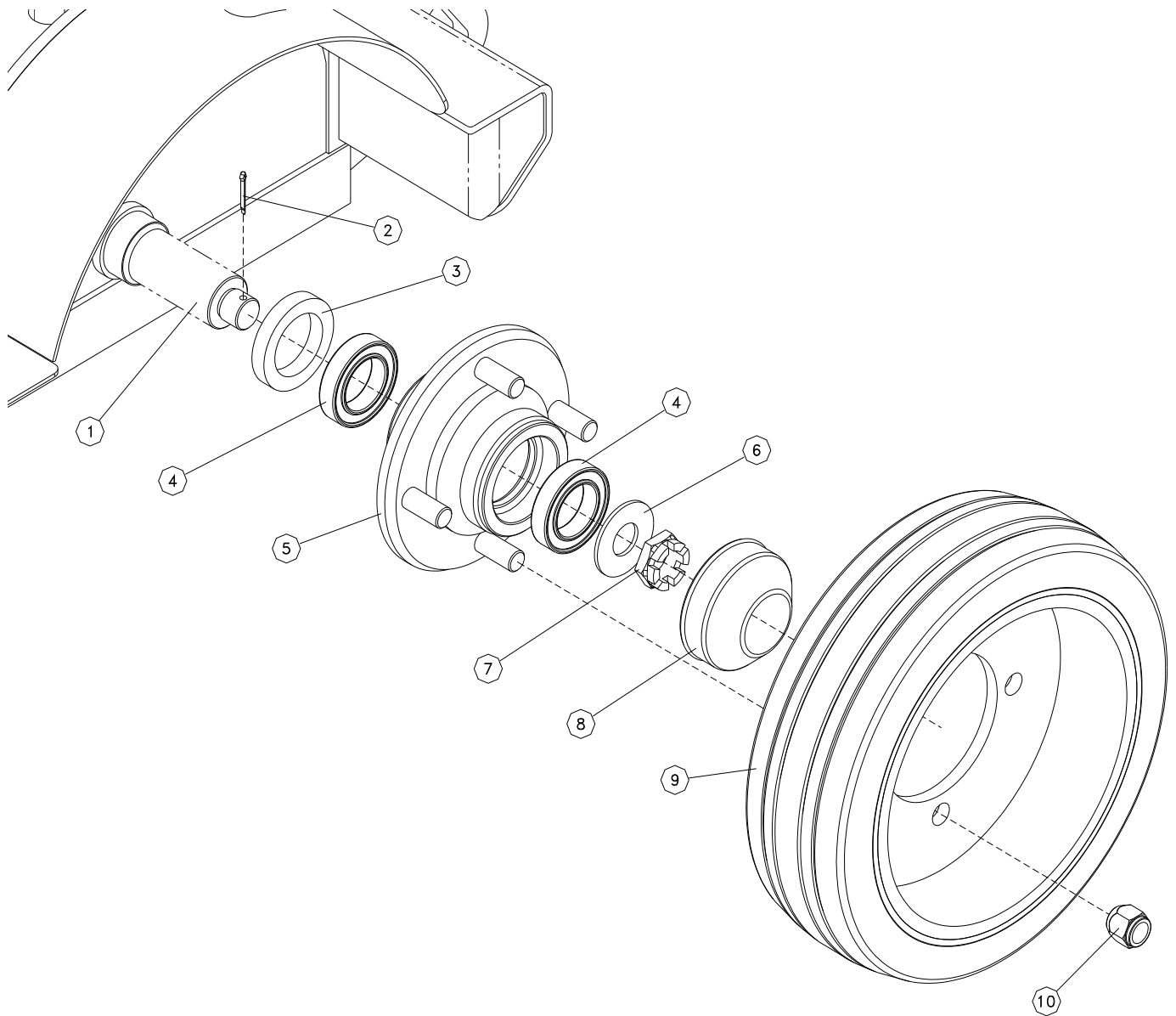

MAST ASSEMBLY MB20N

Item	Part No.	Description	Qty.
1	500717-000	Mast #1 Weldment	1
2	500718-000	Mast #2 Weldment	1
3	500719-000	Mast #3 Weldment	1
4	500720-000	Mast #4 Weldment	1
5	500721-000	Jib Mount Weldment	1
6	500722-050	Hex Head Bolt M10 x 50	12
7	056960-010	Washer M10	12
8	501659-000	Wear Pad Kit	1
9	500861-000	Jib Mount Cover Plate	1
10	500871-001	Slide Channel	1
11	500882-000	Slide Channel Cover	1
12	501550-000	Energy Chain Weldment	1
13	500875-000	Lower Guide Trunking	1
14	501274-000	Trunking Cover	2
15	501211-001	Mast Energy Chain (27 L)	1
16	500871-002	Slide Channel	1
17	501211-000	Mast Energy Chain (50 L)	1

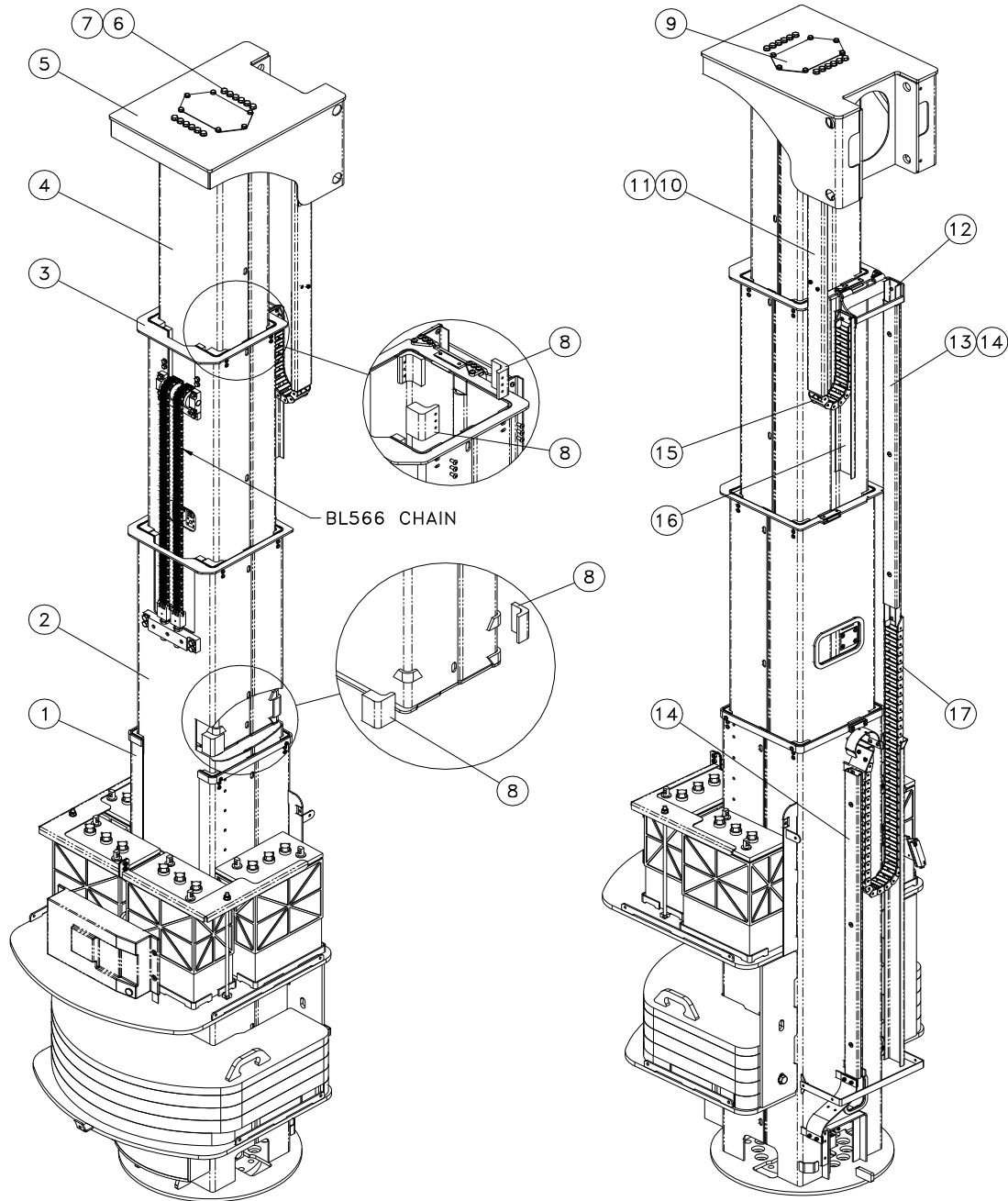

MAST ASSEMBLY MB26

Item	Part No.	Description	Qty.
1	500717-000	Mast #1 Weldment	1
2	500718-000	Mast #2 Weldment	1
3	500719-000	Mast #3 Weldment	1
4	500720-001	Mast #4 Weldment	1
5	500863-000	Mast #5 Weldment	
6	500721-001	Jib Mount Weldment	1
7	500722-050	Hex Hd Bolt M10 x 50	12
8	056960-010	Washer M10	12
9	501659-001	Wear Pad Kit	1
10	500861-000	Jib Mount Cover Plate	1
11	500871-003	Slide Channel	1
12	500882-001	Slide Channel Cover	1
13	501211-000	Mast Energy Chain (50 L)	2
14	500871-002	Slide Channel	1
15	501274-000	Trunking Cover	2
16	501550-000	Energy Chain Weldment	1
17	500875-000	Lower Guide Trunking	1

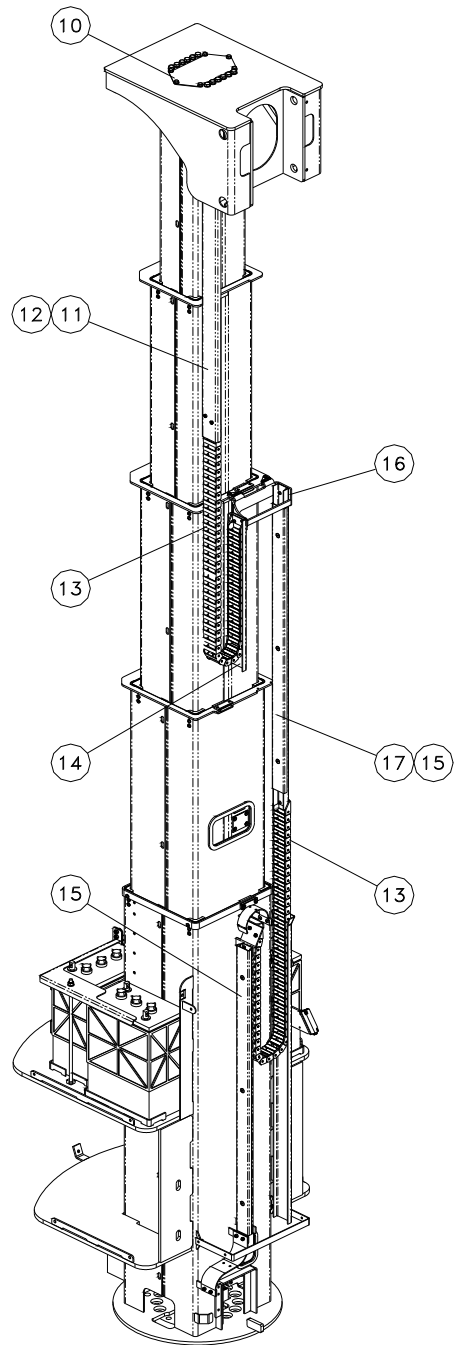
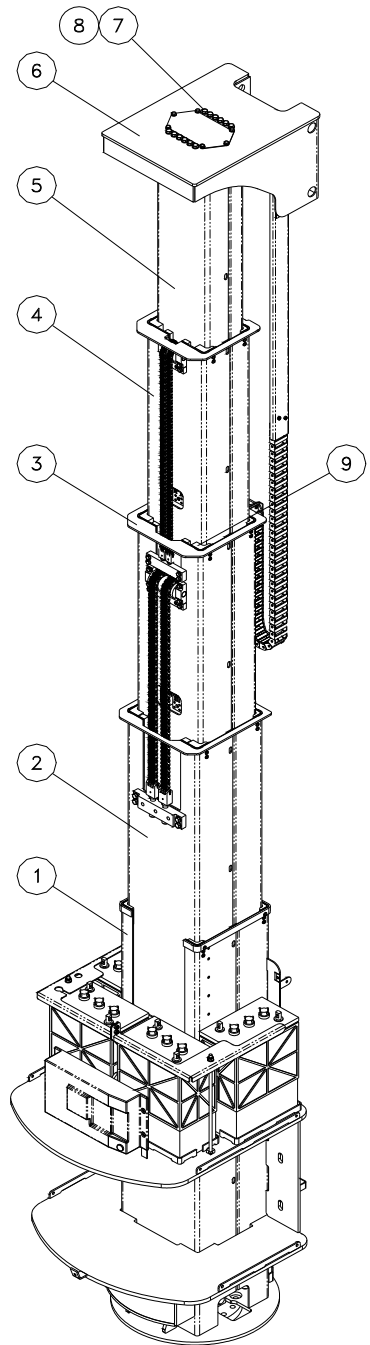

WEAR PAD KIT

MB20N 501659-000

Item	Part No.	Description	Qty.
1	500820-000	Lower Slide 10mm	8
2	500820-001	Upper Slide 10mm	2
3	500820-003	Upper Slide 11mm	4
4	501299-000	Lower Slide 26mm	4
5	501299-002	Upper Slide 27mm	4
6	501253-016	Button Hd Screw M6	4
7	501253-012	Button Hd Screw M6	32

MB26 501659-001

Item	Part No.	Description	Qty.
1	500820-000	Lower Slide 10mm	8
2	500820-001	Upper Slide 10mm	2
3	500820-002	Lower Slide 10mm	2
4	500820-003	Upper Slide 11mm	4
5	500820-004	Upper Slide 11mm	2
6	501299-002	Lower Slide 27mm	4
7	501299-000	Upper Slide 26mm	4
8	501253-016	Button Hd Screw M6	4
9	501253-012	Button Hd Screw M6	44

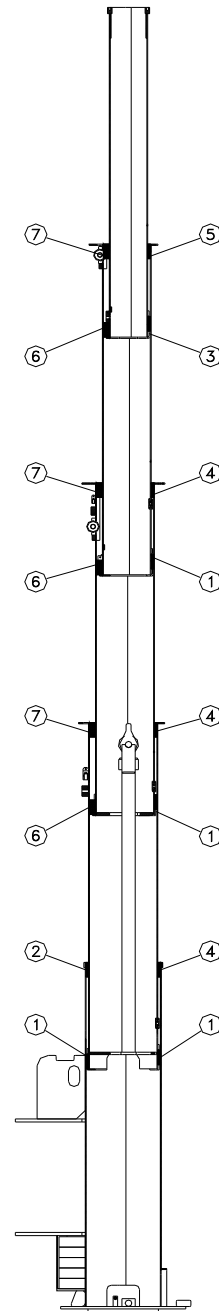
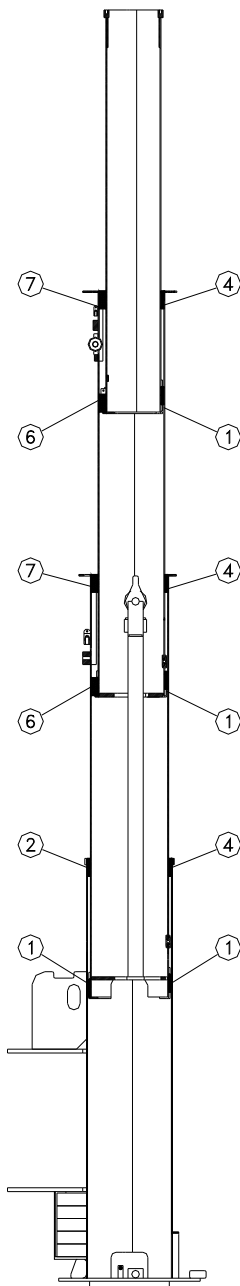

MAST #1 SUB-ASSEMBLY MB20N

Item	Part No.	Description	Qty.
1	500717-000	Mast #1 Weldment	1
2	501575-000	Battery Indicator	1
3	501598-000	Indicator Mounting Plate	1
4	501422-000	Tie-Down Plate LH	1
5	501238-001	Battery Charger (CE)	1
5	501238-002	Battery Charger (ANSI)	1
6	500819-000	Top Hose Guide	1
7	500875-001	Mast #1 Trunking	1
8	501422-001	Tie-Down Plate RH	1
9	501237-001	Battery 6V	4
10	500890-000	Slide Channel Weldment	1
11	501423-000	Tie-Down Bar	

Item	Part No.	Description	Qty.
12	501388-000	Mast Cover Bracket	1
13	500885-000	Bottom Hose Guide	1
14	501381-000	Lever Hand Actuator	1
15	501451-000	Lever Actuator Cover	1
16	501473-000	Lever Cable	1
17	53195-02	Lever Cable Crimp	2
18	501425-000	Magnetic Limit Switch	1
19	501393-000	Switch Mounting Bracket	1
20	501383-000	Guide Weldment	1
21	REF	Lever Pivot Bracket	1
22	501382-000	Lever Actuator Bracket	1

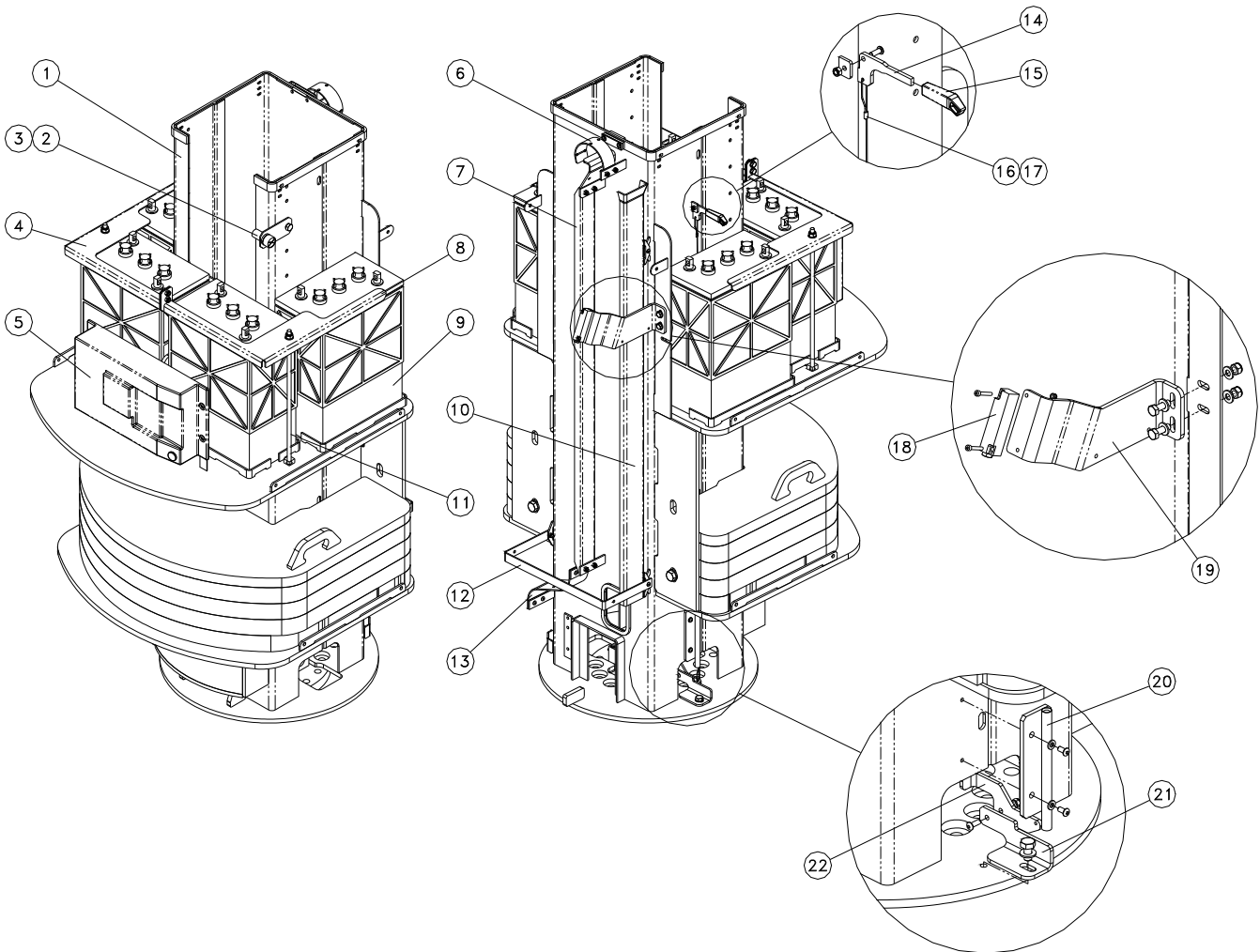

MAST #1 SUB-ASSEMBLY MB26

Item	Part No.	Description	Qty.
1	500717-000	Mast #1 Weldment	1
2	501575-000	Battery Indicator	1
3	501598-000	Indicator Mounting Plate	1
4	501422-000	Tie-Down Plate LH	1
5	501238-001	Battery Charger (CE)	1
5	501238-002	Battery Charger (ANSI)	1
6	500819-000	Top Hose Guide	1
7	500875-001	Mast #1 Trunking	1
8	501422-001	Tie-Down Plate RH	1
9	501237-001	Battery 6V	4
10	500890-000	Slide Channel Weldment	1
11	501423-000	Tie-Down Bar	

Item	Part No.	Description	Qty.
12	501388-000	Mast Cover Bracket	1
13	500885-000	Bottom Hose Guide	1
14	501381-000	Lever Hand Actuator	1
15	501451-000	Lever Actuator Cover	1
16	501473-000	Lever Cable	1
17	53195-02	Lever Cable Crimp	2
18	501425-000	Magnetic Limit Switch	1
19	501393-001	Switch Mounting Bracket	1
20	501383-000	Guide Weldment	1
21	REF	Lever Pivot Bracket	1
22	501382-000	Lever Actuator Bracket	1

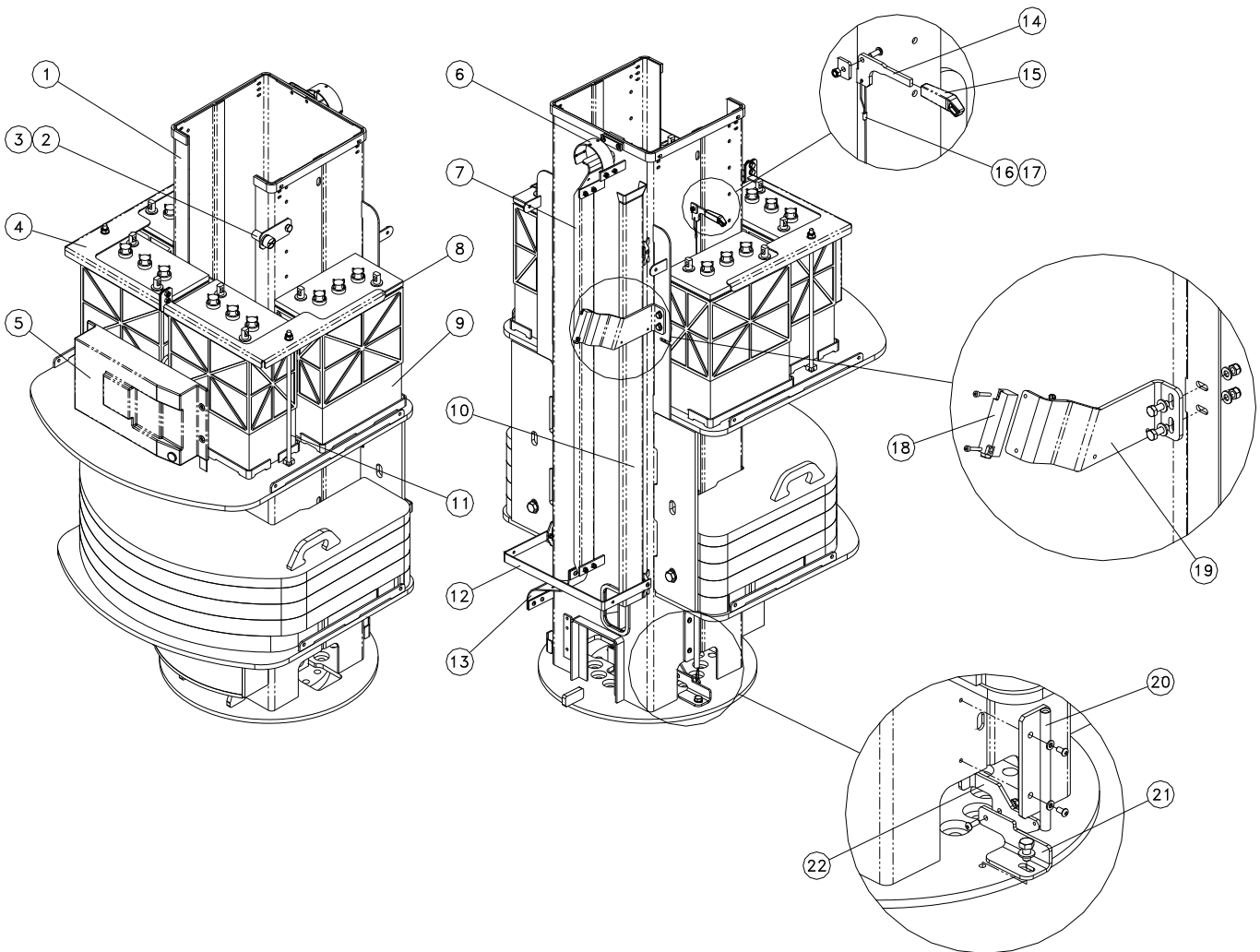

LOWER CHAIN GROUP (BL666)

Item	Part No.	Description	Qty.
1	501307-000	Chain Anchor Block	1
2	501301-000	Anchor Pin	1
3	500858-000	Knob	1
4	501563-025	Split Pin	2
5	501209-000	BL666 Chain (Complete)	1
6	501247-030	Socket Head Screw	1
7	056021-012	Spring Washer	1
8	501310-000	Tensioner Fork	2
9	501323-001	BL666 Brace	1
10	501302-000	Tensioner Pin	2
11	501244-012	Split Pin	4
12	056066-006	Nylock Nut M6	2
13	501253-035	Button Head Screw M6	2
14	056069-020	Washer M20	2
15	056067-020	Nut M20	2
16	056067-520	Locknut M20	2
17	501313-000	BL666 Dual Pulley	1
18	501057-020	Roll Pin	2
19	500853-000	BL666 Pulley Axle	1
20	500722-000	Cylinder Mount Weldment	1
21	501432-000	Internal Circlip	2
22	501291-000	Bearing Washer	2
23	501342-000	Roller Bearing	2
24	501378-000	Pulley Sleeve	1

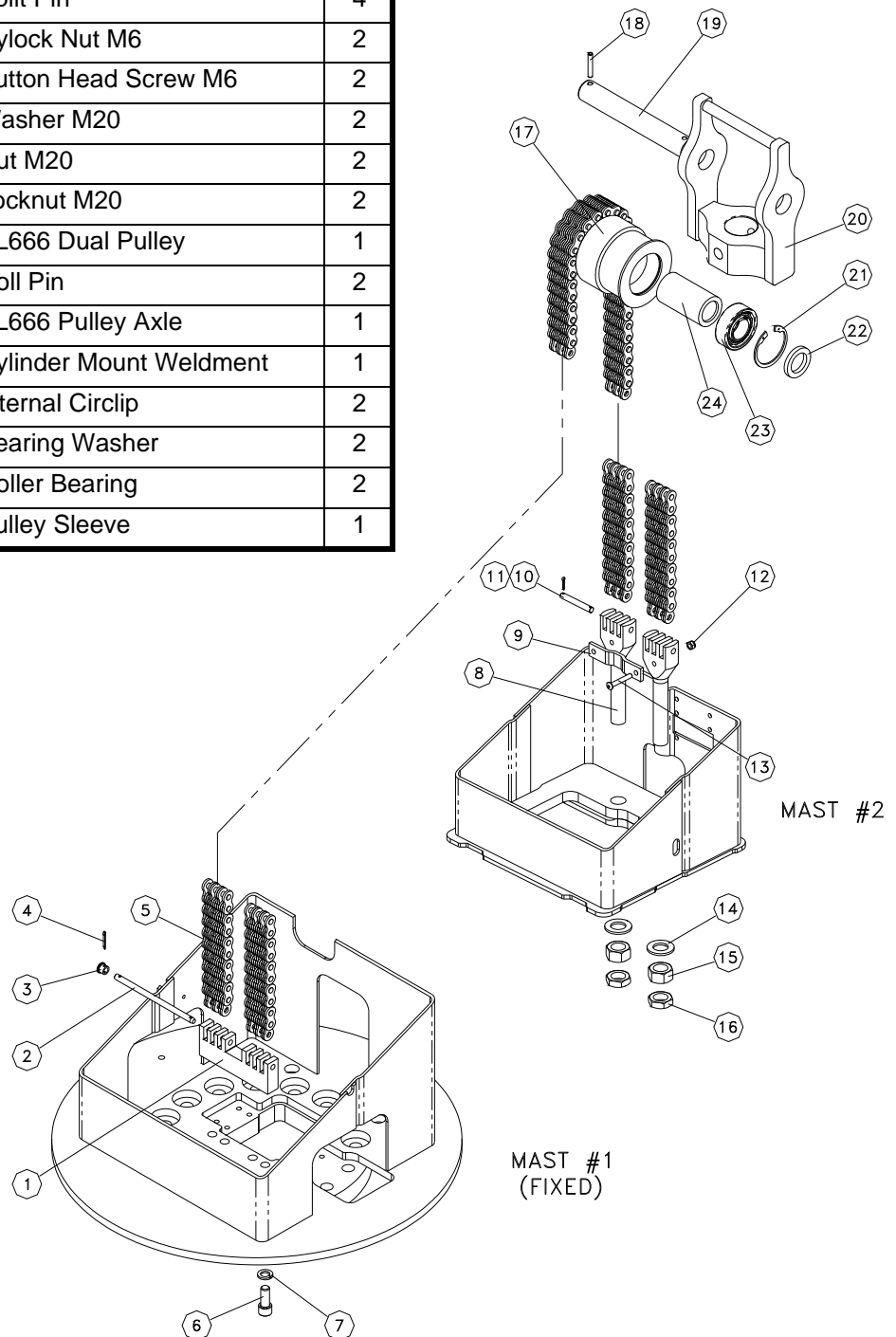

INTERMEDIATE CHAIN GROUP (BL566)

Item	Part No.	Description	Qty.
1	501311-000	Anchor Block	2
2	501304-000	End Pin	4
3	501244-012	Split Pin	8
4	501208-000	BL566 Chain (Complete)	2
5	058492-025	Hex Hd Screw	8
6	056069-008	Washer	20
7	500860-016	Roll Pin	4
8	501314-000	BL666 Dual Pulley	1
9	501064-000	Bushing	2
10	501303-000	Pulley Axle	1
11	501321-000	Pulley Mount	2
12	501317-000	Base Mount	1
13	058492-020	Hex Hd Screw M8	6
14	501316-000	Back Mount	2
15	056059-035	Hex Hd Bolt M8	6
16	501057-020	Roll Pin	3
17	501431-100	Socket Hd Screw M16	2
18	500860-020	Roll Pin	3
19	500854-000	Tensioner Mount	1
20		Hex Hd Screw M10	4
21	056169-010	Washer M10	6
22	058493-020	Hex Hd Screw M10	2
23	501320-000	Back Mount	2
24	501308-000	Tensioner	2
25	056067-516	Lock Nut M16	2

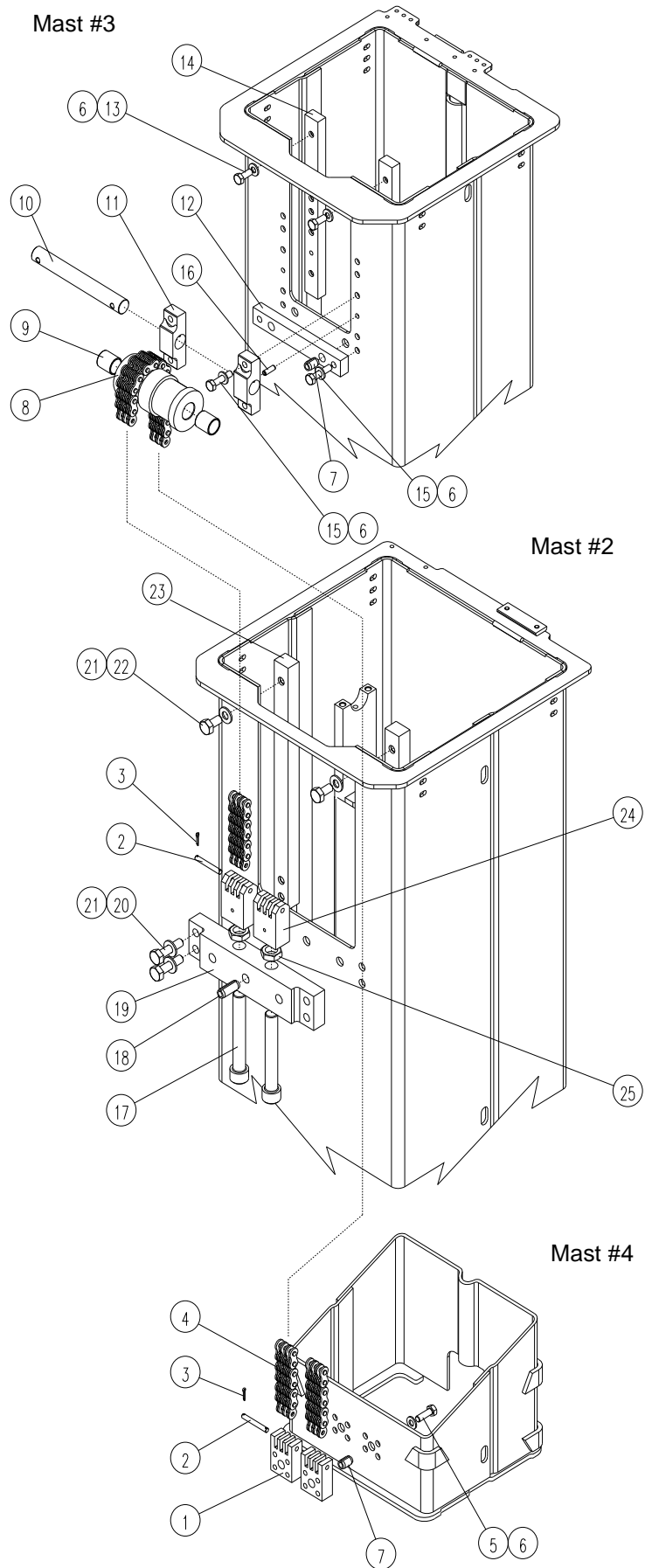

TOP CHAIN GROUP (BL444) (MB26 ONLY)

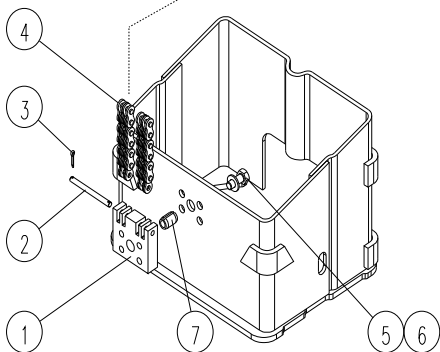
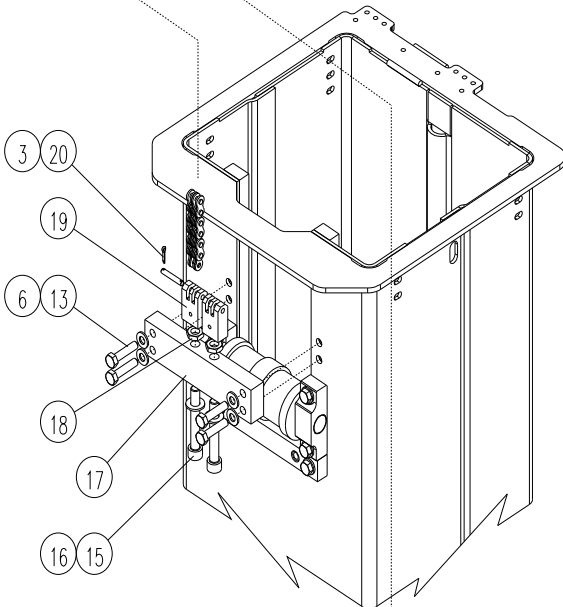
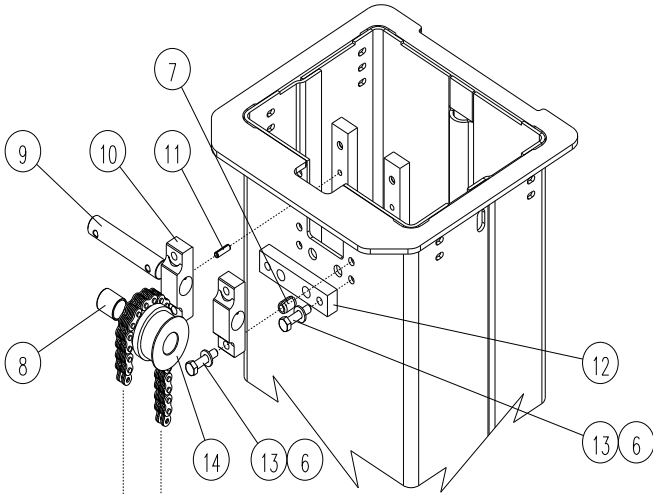

Item	Part No.	Description	Qty.
1	501312-000	Anchor Block	1
2	501305-000	Anchor Pin	2
3	501244-012	Split Pin	6
4	501207-000	BL444 Chain (Complete)	2
5	058492-020	Hex Hd Screw M8	4
6	056069-008	Washer M8	14
7	500860-016	Roll Pin	3
8	501064-000	Bushing	2
9	501303-001	Pulley Axle	1
10	501321-000	Pulley Mount	1
11	501057-020	Roll Pin	2
12	501319-000	Base Mount	1
13	056059-035	Hex Hd Screw M8	10
14	501315-000	BL666 Dual Pulley	1
15	501571-070	Hex Hd Bolt M10	2
16	056169-010	Washer M10	2
17	501325-000	Tensioner Mount	1
18	056067-510	Lock Nut M10	2
19	501309-000	Tensioner	2
20	501305-001	Tensioner Pin	2

SEQUENCE STRAPS

MB20N

Item	Part No.	Description	Qty.
1	500851-000	Strap Clip Upper	2
2	500850-000	Strap Clip Lower	2
3	501287-000	Roller Support Block	8
4	500852-000	Strap Clip Shaft	2
5	500873-000	Strap Guide	2
6	500849-000	Strap Bushing	2
7	501270-001	Clamp Plate - Threaded	2
8	501270-000	Clamp Plate - Outer	2
9	501210-001	Sequence Strap	2

MB26

Item	Part No.	Description	Qty.
1	500851-000	Strap Clip Upper	3
2	500850-000	Strap Clip Lower	3
3	501287-000	Roller Support Block	12
4	500852-000	Strap Clip Shaft	3
5	500873-000	Strap Guide	3
6	500849-000	Strap Bushing	3
7	501270-001	Clamp Plate - Threaded	3
8	501270-000	Clamp Plate - Outer	3
9	501210-001	Sequence Strap	3

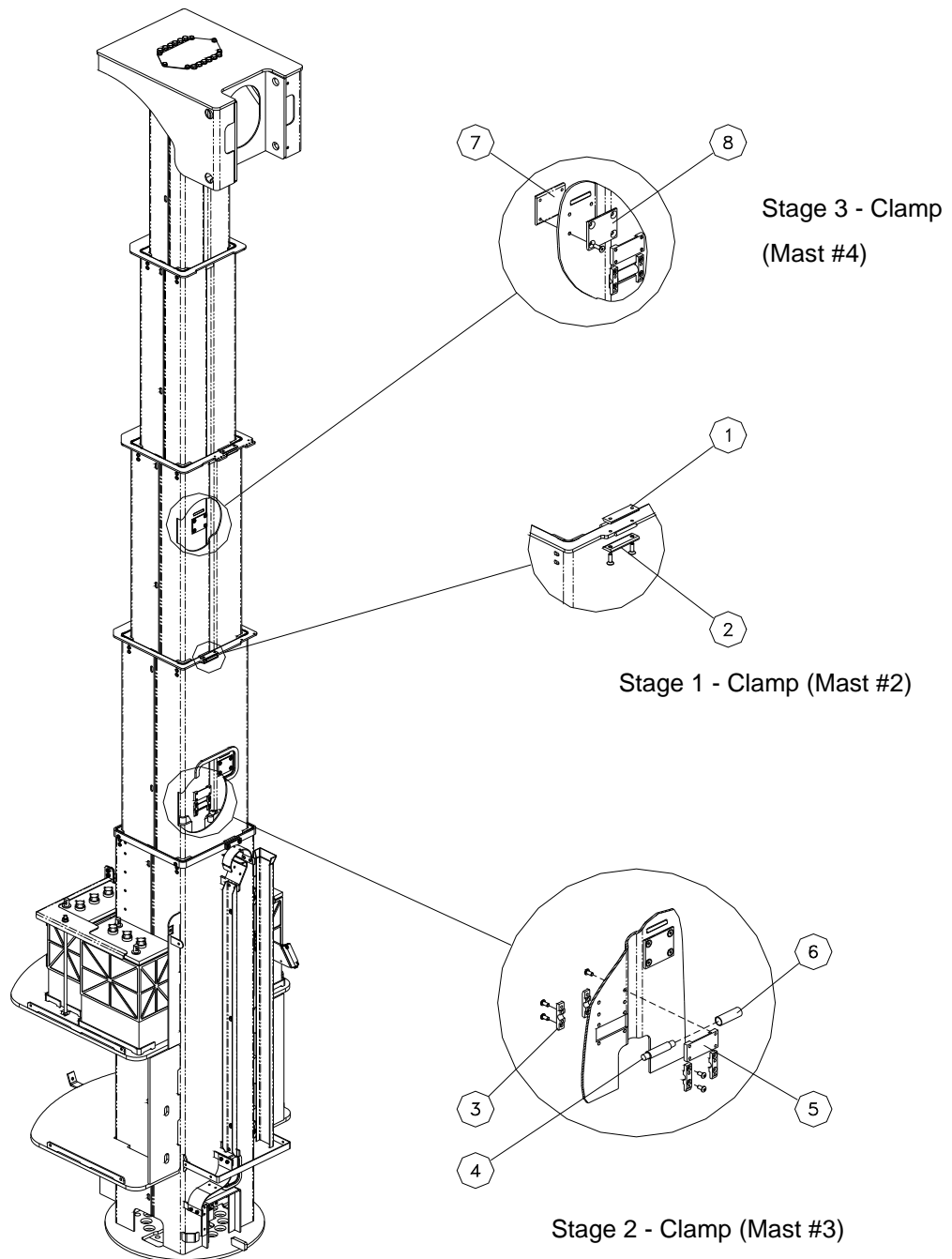

MAIN LIFT CYLINDER MOUNTING

Item	Part No.	Description	Qty.
1	500838-000	Anchor Block	2
2	058503-060	Socket Hd Screw M8	8
3	500784-000	Stand Pipe Adaptor	2
4	057033-000	Circlip (External)	2
5	501324-000	Anchor Pin	1
6	500780-000	Lift Cylinder Assembly	1
7	058480-100	Hex Hd Bolt	1
8	056064-016	Lock Nut M16	1
9	501445-001	Cylinder Mount Assembly	1
10	500864-000	Shaft Cap	2
11	058503-045	Socket Hd Screw M8	4
12	056069-008	Washer M8	4

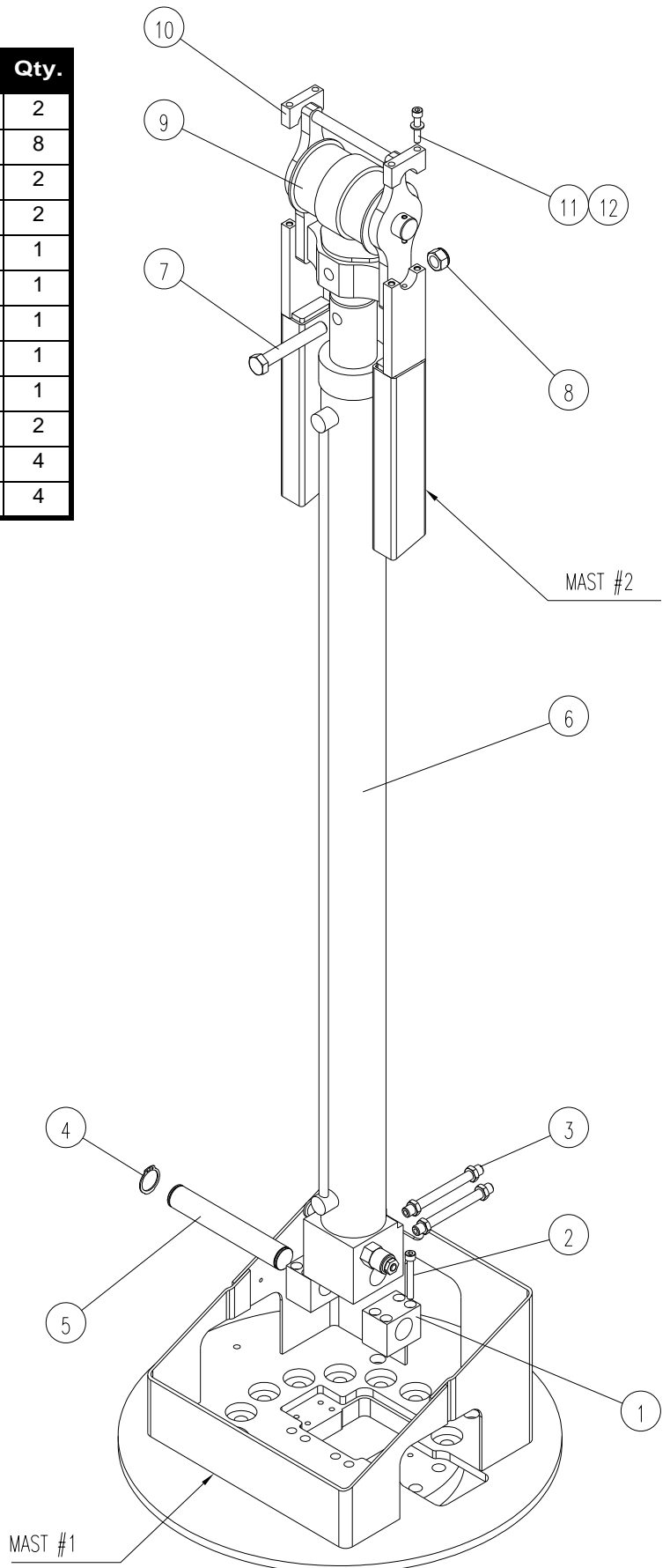

MAIN LIFT CYLINDER

MB20N

Item	Part No.	Description	Qty.
1		Body End Block	1
2	058728-000	Over-Centre Valve	1
3	501664-000	Seal Kit	1
4		Collar Locking Washer	1
5		Cylinder Body	1
6		Washer Tab	1
7		Rod End Cap	1
8		Cylinder Rod	1
9		Piston Head Cap	1
10		Piston Head	1
11		Nylock Nut	1
12		Washer	1
13		Circlip	1
14	500397-000	Emergency Lowering Valve	1

MB26

Item	Part No.	Description	Qty.
1		Body End Block	1
2	058728-000	Over-Centre Valve	1
3	501664-000	Seal Kit	1
4		Collar Locking Washer	1
5		Cylinder Body	1
6		Washer Tab	1
7		Rod End Cap	1
8		Cylinder Rod	1
9		Piston Head Cap	1
10		Piston Head	1
11		Nylock Nut	1
12		Washer	1
13		Circlip	1
14	500397-000	Emergency Lowering Valve	1

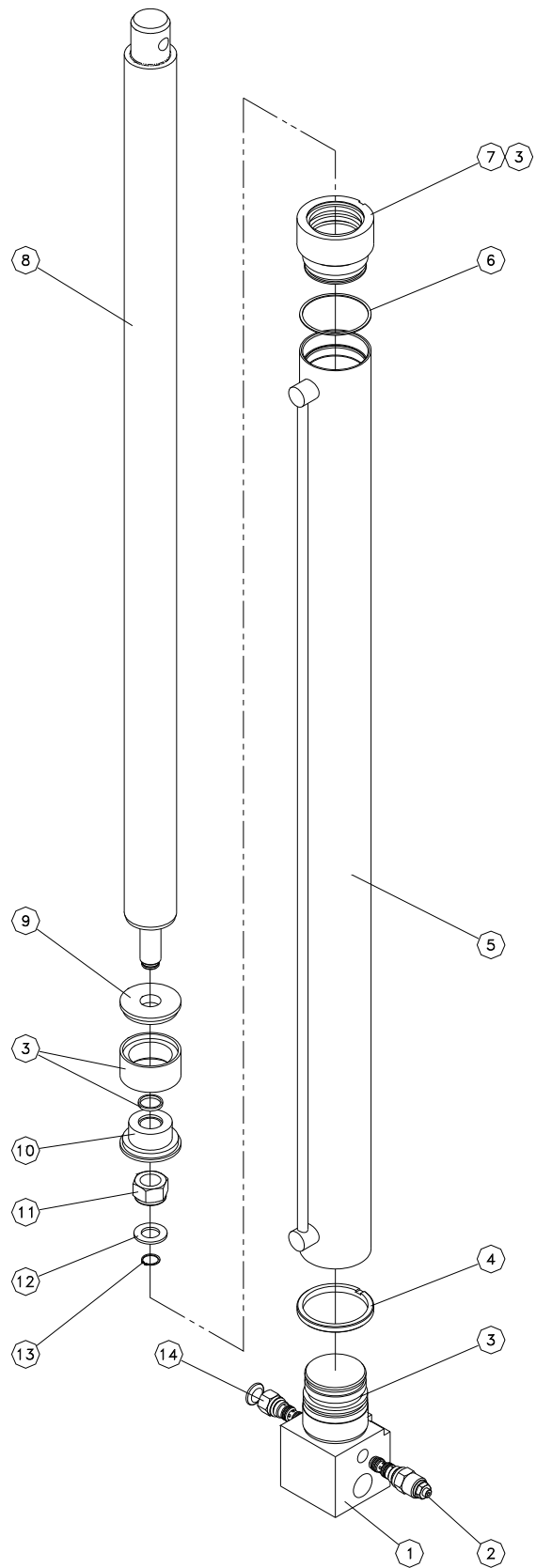

JIB & CAGE ASSEMBLY (INCLUDING OVERLOAD)

MB20N

Item	Part No.	Description	Qty.
1	501231-000	Pivot Pin (Jib Mount)	2
2		Jib Cylinder Assembly	1
3	500761-000	Upper Control Box Mounting Plate	1
4	501450-000	Cage Rail Weldment	1
5	501504-000	Upper Control Box Assembly	1
6	010076-000	Operators Manual Holder	1
7	500810-000	Drop Bar	1
8	501352-000	Ladder Catch	1
9	501351-000	Ladder Catch Bracket	1
10	501350-000	Ladder	1
11	501357-000	Hinge Bracket Weldment	1
12	501358-000	Rope Pull Bracket	1
13	501353-000	Wire Rope	1
14	501354-000	Ladder Crimp	4
15	500725-000	Cage Base Weldment	1
16	057094-000	Harness Anchor	1
17	501230-000	Pivot Pin Cage Connect	2
18	500078-000	Flanged Bush	8
19	501356-000	Foot-Pedal Mounting	1
20	501355-000	Foot-Pedal Weldment	1
21	501269-000	Pivot Pin - Jib Cylinder Rod	1
22	058056-000	Lock Plate	2
23	500723-000	Jib Tie Weldment	1
24	500724-000	Jib Strut Weldment	1
25	057054-000	Flanged Bush	8
26	057033-000	Circlip (External)	2
27	501583-000	Cage Overload Beam	2
28	501230-001	Pivot Pin (Cage Overload)	2
29	501605-000	Overload Pin Retainer	1
30	501584-000	Overload Striker Bar	1
31	501606-000	Overload Cover Guard	1
32	501611-000	Proximity Switch	1
33	501621-000	Overload Pin Spacer	2

MB26

Item	Part No.	Description	Qty.
1	501231-000	Pivot Pin (Jib Mount)	2
2		Jib Cylinder Assembly	1
3	500761-000	Upper Control Box Mounting Plate	1
4	501450-000	Cage Rail Weldment	1
5	501504-000	Upper Control Box Assembly	1
6	010076-000	Operators Manual Holder	1
7	500810-000	Drop Bar	1
8	501352-000	Ladder Catch	1
9	501351-000	Ladder Catch Bracket	1
10	501350-000	Ladder	1
11	501357-000	Hinge Bracket Weldment	1
12	501358-000	Rope Pull Bracket	1
13	501353-000	Wire Rope	1
14	501354-000	Ladder Crimp	4
15	500725-000	Cage Base Weldment	1
16	057094-000	Harness Anchor	1
17	501230-000	Pivot Pin Cage Connect	2
18	500078-000	Flanged Bush	8
19	501356-000	Foot-Pedal Mounting	1
20	501355-000	Foot-Pedal Weldment	1
21	501269-000	Pivot Pin - Jib Cylinder Rod	1
22	058056-000	Lock Plate	2
23	500723-000	Jib Tie Weldment	1
24	500724-000	Jib Strut Weldment	1
25	057054-000	Flanged Bush	8
26	057033-000	Circlip (External)	2
27	501583-000	Cage Overload Beam	2
28	501230-001	Pivot Pin (Cage Overload)	2
29	501605-000	Overload Pin Retainer	1
30	501584-000	Overload Striker Bar	1
31	501606-000	Overload Cover Guard	1
32	501611-000	Proximity Switch	1
33	501621-000	Overload Pin Spacer	2

JIB & CAGE ASSEMBLY

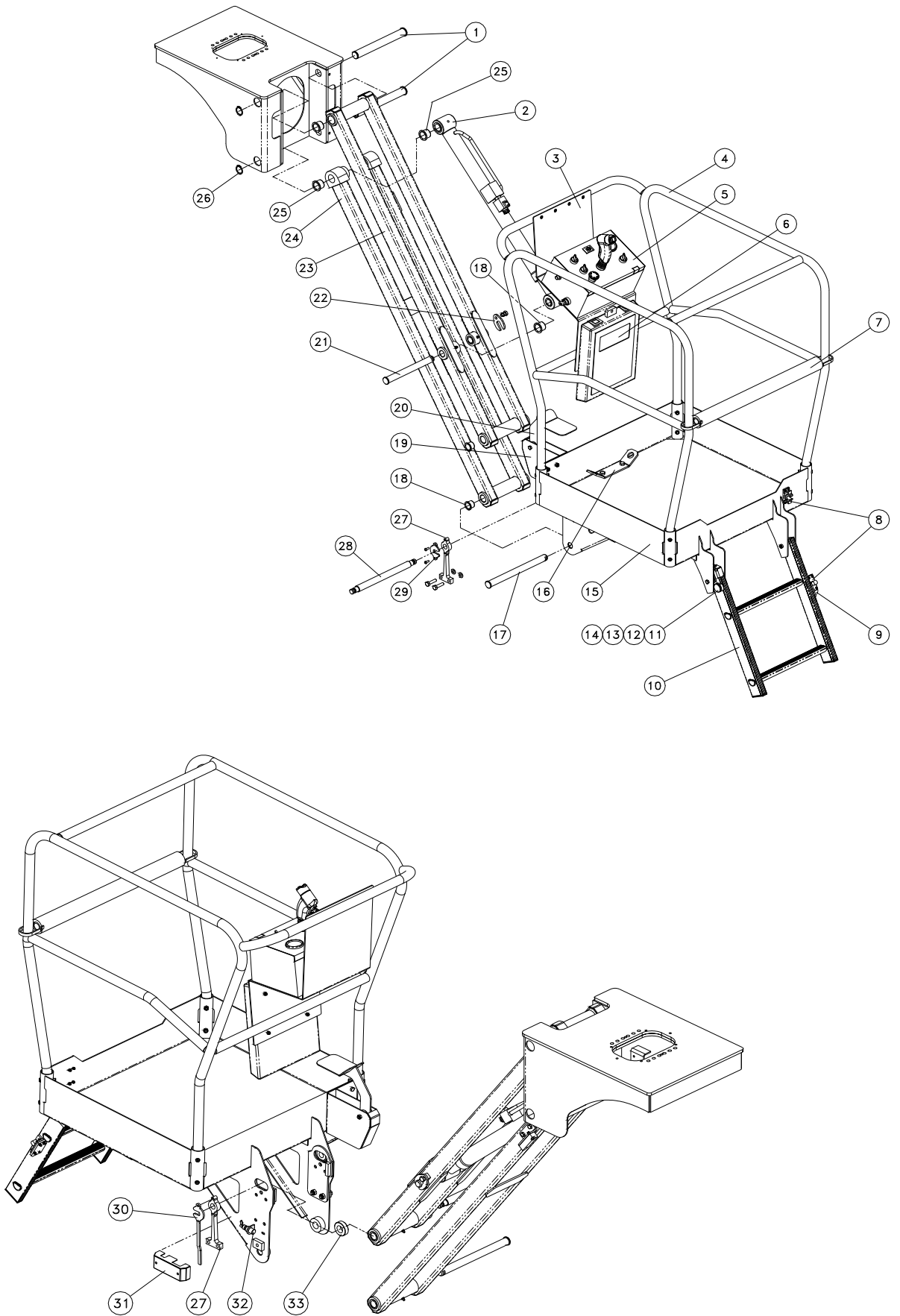

JIB CYLINDER

MB20N - 501480-000

Item	Part No.	Description	Qty.
1		Cylinder Body	1
2	501483-000	Hydraulic Valve	1
3		Rod End Cap	1
4	501662-000	Seal Kit	1
5	058819-001	Grease Nipple M8	2
6		Cylinder Rod	1
7		Bearing Ring	1

MB26 - 501480-001

Item	Part No.	Description	Qty.
1		Cylinder Body	1
2	501483-000	Hydraulic Valve	1
3		Rod End Cap	1
4	501662-000	Seal Kit	1
5	058819-001	Grease Nipple M8	2
6		Cylinder Rod	1
7		Bearing Ring	1

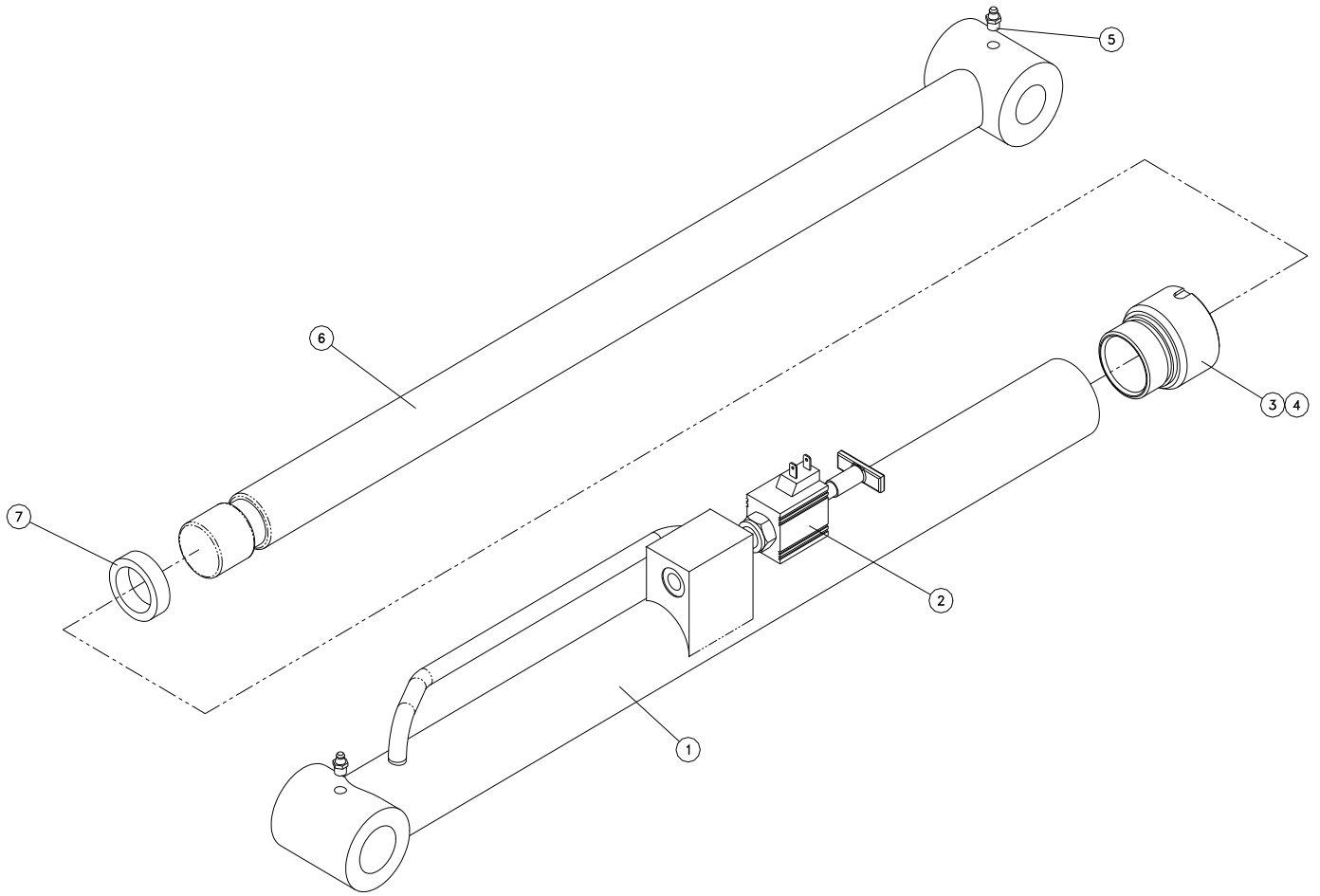

LOWER CONTROL PANEL

Item	Part No.	Description	Qty.
1	501871-000	PCB Assembly	1
2	501867-000	Emergency Stop Button	1
3	508033-000	Contact Block	1
4		K12 Switch Actuator	1
5		Ground Control Panel	1
6	501872-000	Rocker Switch	
7		Wire Harness	
8	502506-000	Overlay	

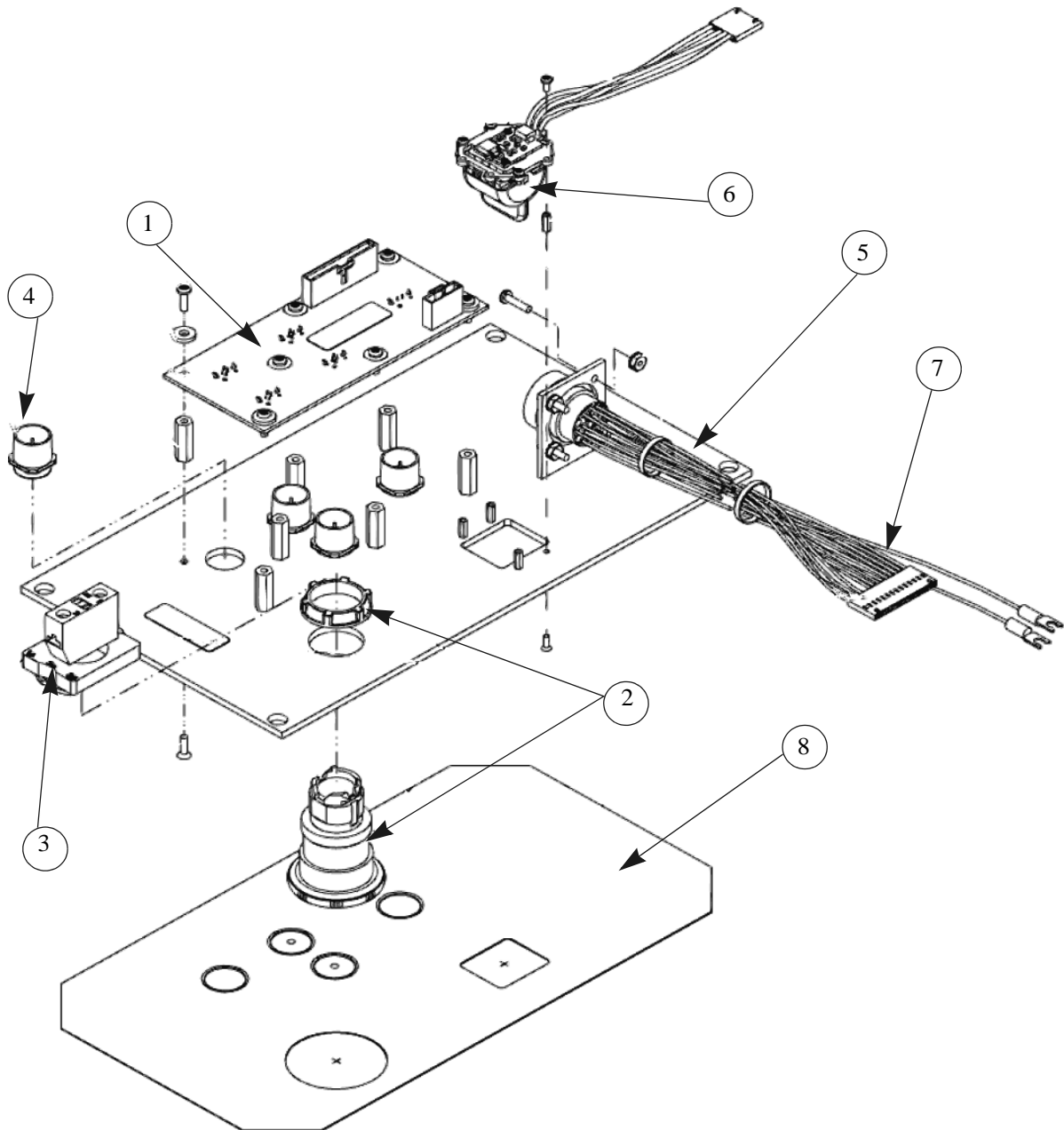

PLATFORM CONTROLS PANEL

Item	Part	Description	Qty.
1	502453-000	CIRCUIT BOARD	1
2	501866-000	KEY SWITCH	1
3	501867-000	EMERGENCY STOP BUTTON	1
4	503291-000	DECAL	1
5	501881-000	ENCLOSURE	1
6	501882-000	JOYSTICK	1
7	501882-002	JOYSTICK BOOT	1
8	501882-001	JOYSTICK STEERING BOOT	1
9	501866-001	KEY	1

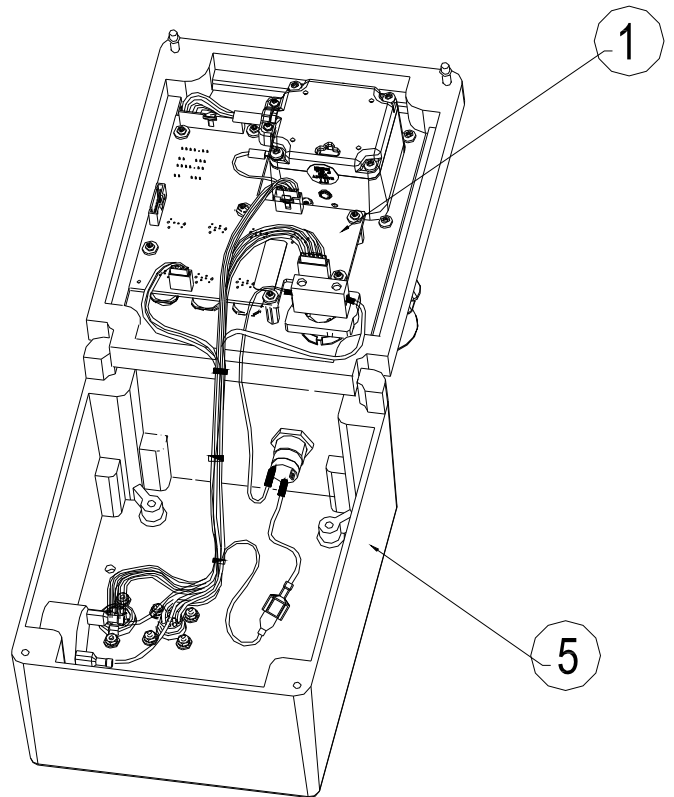
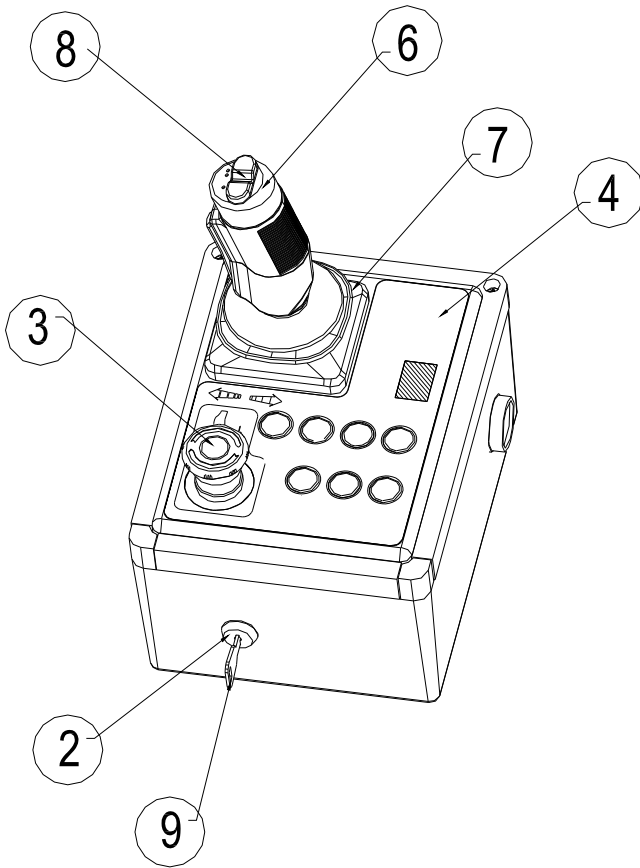

Illustrated Parts List

ECU ASSEMBLY 501243-003

Item	Part No.	Description	Qty.
1	501871-000	PCB Assembly	1
2	501867-000	Emergency Stop Button	1
3	508033-000	Contact Block	1
4		K12 Switch Actuator	1
5		Ground Control Panel	1
6	501872-000	Rocker Switch	
7		Wire Harness	
8	502506-000	Overlay	

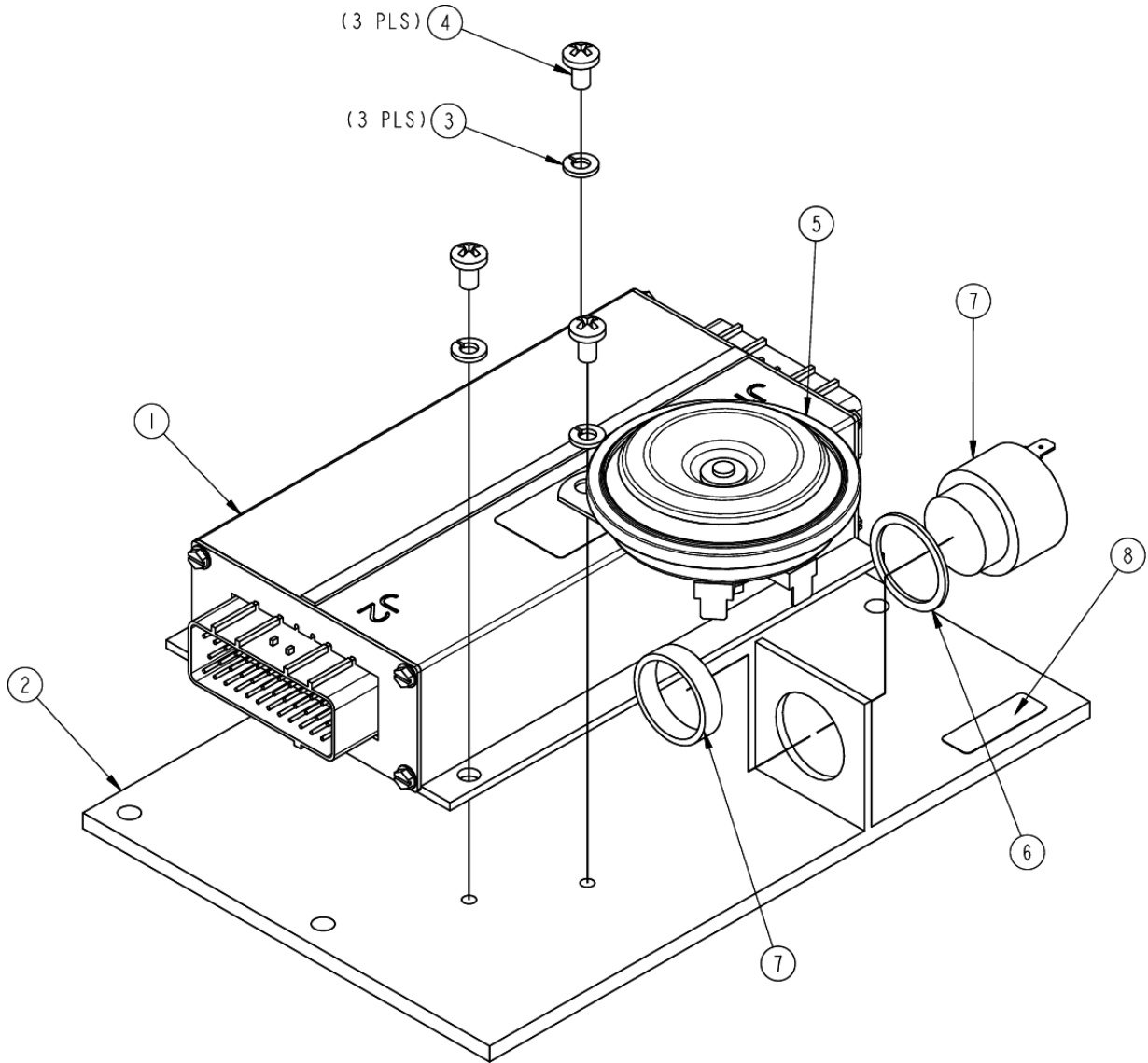

ELECTRICAL SYSTEM LAYOUT

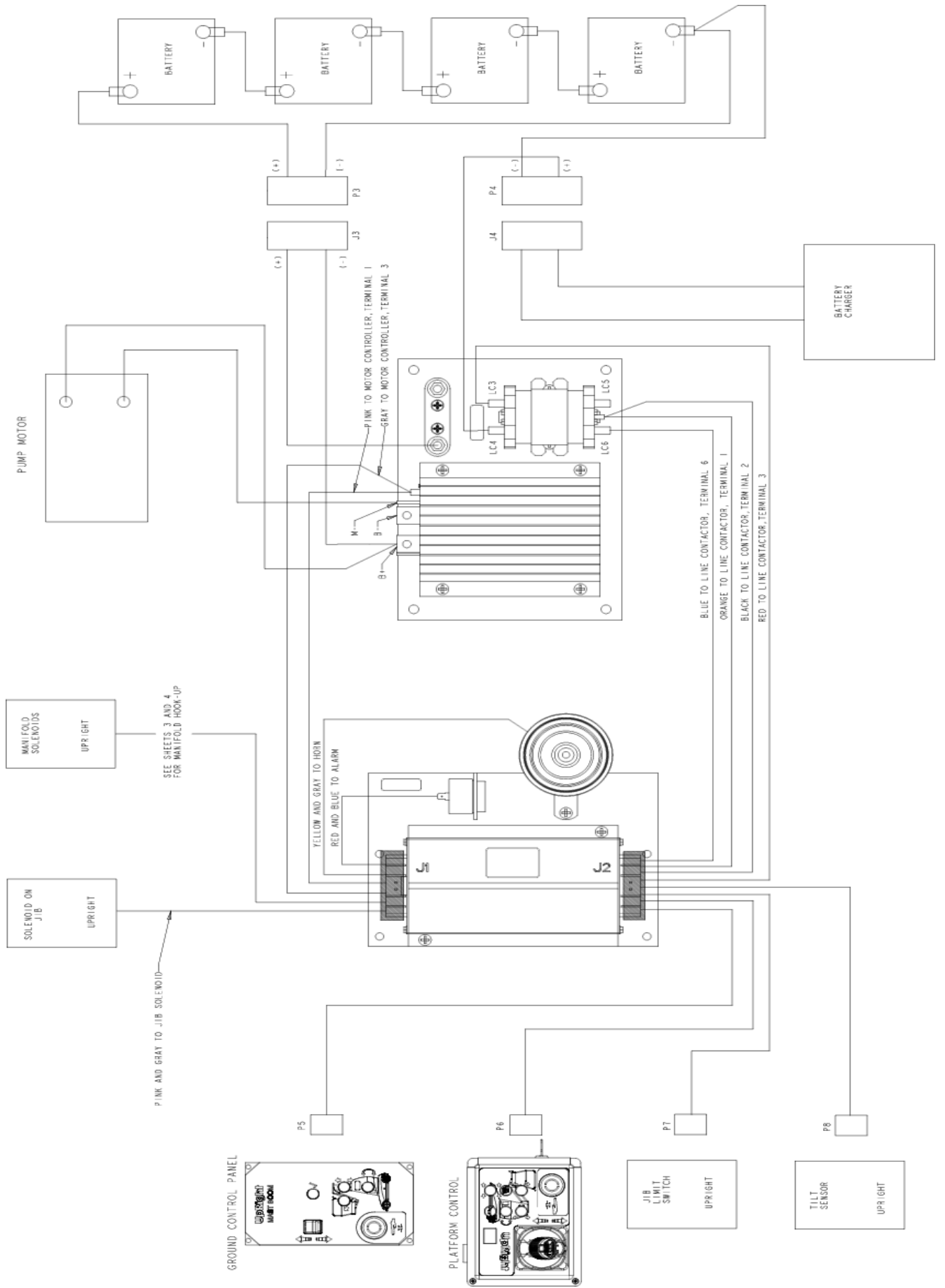

HYDRAULIC VALVE MANIFOLD 501471-000

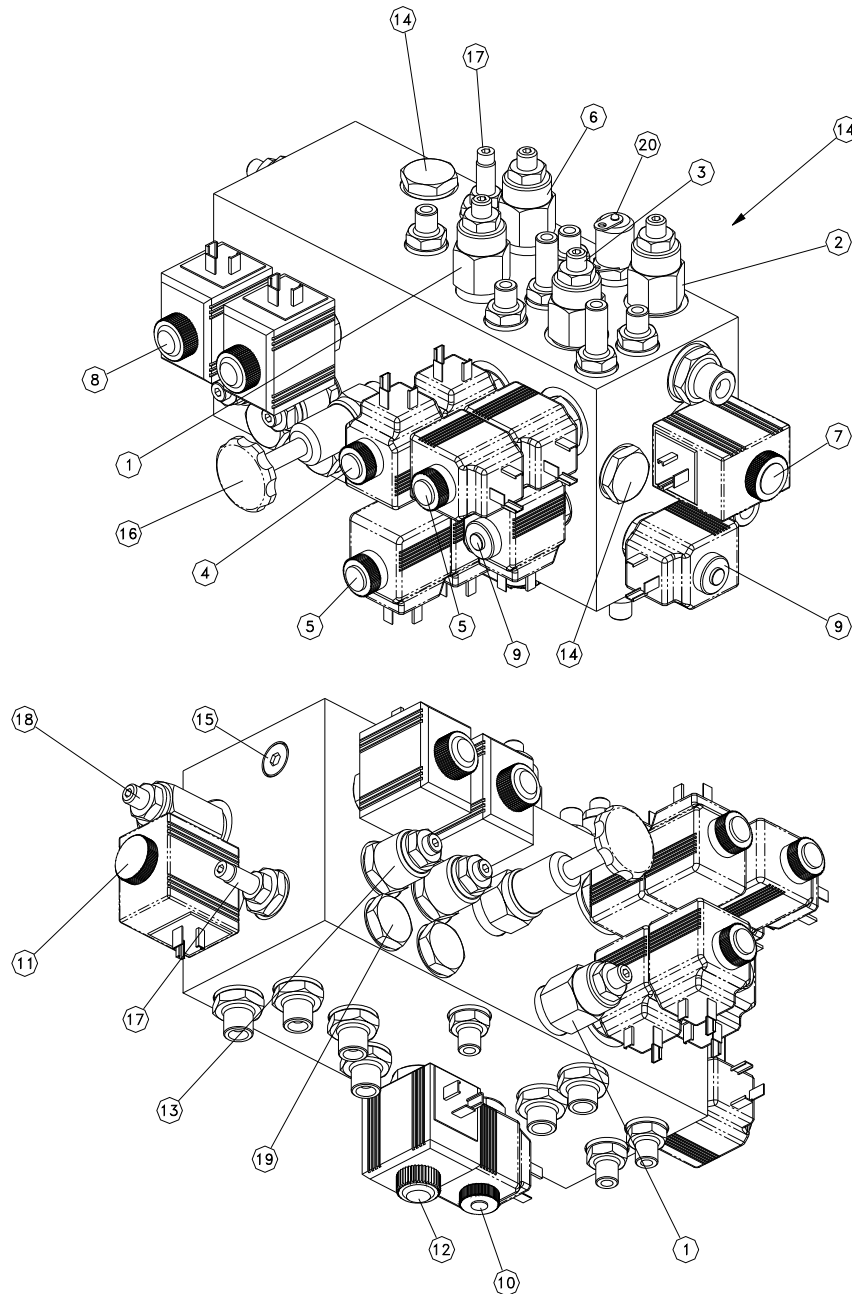

Item	Part No.	Description	Qty.
1	058722-001	Relief Cartridge CT12-13	2
2	058722-002	Relief Cartridge CT10	1
3	058722-003	Relief Cartridge CT11	1
4	058723-000	Solenoid Cartridge CT1	1
5	058726-002	Solenoid Cartridge CT2-6	2
6	501486-000	Relief Cartridge CT25	1
7	501526-000	Solenoid Cartridge CT3	1
8	501527-000	Check Caartridge CT4-15	2
9	501528-000	Solenoid Cartridge CT7-15	2
10	501479-000	Solenoid Cartridge CT14	1
11	501530-000	Solenoid Cartridge CT23	1
12	501531-000	Solenoid Cartridge CT24	1

Item	Part No.	Description	Qty.
13	501532-000	O/Centre Cartridge CT8-9	2
14	501484-000	Check Cartridge CT16-26-30	3
15	501534-000	Shuttle Cartridge CT17	1
16	501535-000	Hand Pump CT19	1
17	501485-000	Needle Cartridge CT20-21	2
18	501537-000	Pressure Reducer CT22	1
19	501539-000	P.O Check Cartridge CT27-28	2
20	057109-000	Filler Cap & Filter Assembly	1
21	057377-000	Adaptors 1/2" x 1/2"	1
22	057122-000	Adaptors 3/8" x 3/8"	7
23	057358-000	Adaptors 1/4" x 1/4"	10
24	501697-000	Bulkhead Fitting L1 & ST2	2

HYDRAULIC COMPONENT ASSEMBLY

MB26 Hydraulic Assembly			
Item	Part No.	Description	Qty.
1	501233-000	Wheel Motor L/H	1
2	501371-000	Hydraulic Hose	1
3	501372-000	Hydraulic Hose	2
4	501373-001	Hydraulic Hose	1
5	501372-001	Hydraulic Hose	2
6	501268-000	Swivel Fitting	2
7	501430-000	Swivel Fitting	2
8	501268-001	Swivel Fitting	2
9	501233-001	Wheel Motor R/H	1
10	501373-000	Hydraulic Hose	1
11	5011371-001	Hydraulic Hose	1
12	500782-001	Steering Cylinder	1
13	501374-001	Hydraulic Hose	1
14	501374-000	Hydraulic Hose	1
15	058352-000	1/4" Tee	1
16	500285-000	Slew Motor	1
17	501359-000	Hydraulic Hose	2
18	501234-000	Hydraulic Tank	1
19	501364-000	Hydraulic Hose	1
20	501336-000	Hydraulic Hose	1
21	501363-000	Hydraulic Hose	1
22	501361-000	Hydraulic Hose	1
23	501471-000	Manifold Block	1
24	500780-001	Main Lift Cylinder	1
25	500784-000	Standpipe Adaptor	2
26	501365-000	Hydraulic Hose	2
27	501366-001	Hydraulic Hose	1
28	501480-001	Jib Cylinder	1
29	501610-001	Pothole Cylinder	1
30	501360-000	Hydraulic Hose	2
31	501362-000	Hydraulic Hose	1
32	501232-000	Pump/Motor Unit	1

MB20N Hydraulic Assembly			
Item	Part No.	Description	Qty.
1	501233-000	Wheel Motor L/H	1
2	501367-000	Hydraulic Hose	1
3	501368-000	Hydraulic Hose	2
4	501369-001	Hydraulic Hose	1
5	501368-001	Hydraulic Hose	2
6	501268-000	Swivel Fitting	2
7	501430-000	Swivel Fitting	2
8	501268-001	Swivel Fitting	2
9	501233-000	Wheel Motor R/H	1
10	501369-000	Hydraulic Hose	1
11	5011367-001	Hydraulic Hose	1
12	500782-000	Steering Cylinder	1
13	501370-001	Hydraulic Hose	1
14	501370-000	Hydraulic Hose	1
15	058352-000	1/4" Tee	1
16	500285-000	Slew Motor	1
17	501359-000	Hydraulic Hose	2
18	501234-000	Hydraulic Tank	1
19	501364-000	Hydraulic Hose	1
20	501336-000	Hydraulic Hose	1
21	501363-000	Hydraulic Hose	1
22	501361-000	Hydraulic Hose	1
23	501471-000	Manifold Block	1
24	500780-000	Main Lift Cylinder	1
25	500784-000	Standpipe Adaptor	2
26	501365-000	Hydraulic Hose	2
27	501366-000	Hydraulic Hose	1
28	501480-000	Jib Cylinder	1
29	501610-000	Pothole Cylinder	1
30	501360-000	Hydraulic Hose	2
31	501362-000	Hydraulic Hose	1
32	501232-000	Pump/Motor Unit	1

HYDRAULIC COMPONENT ASSEMBLY

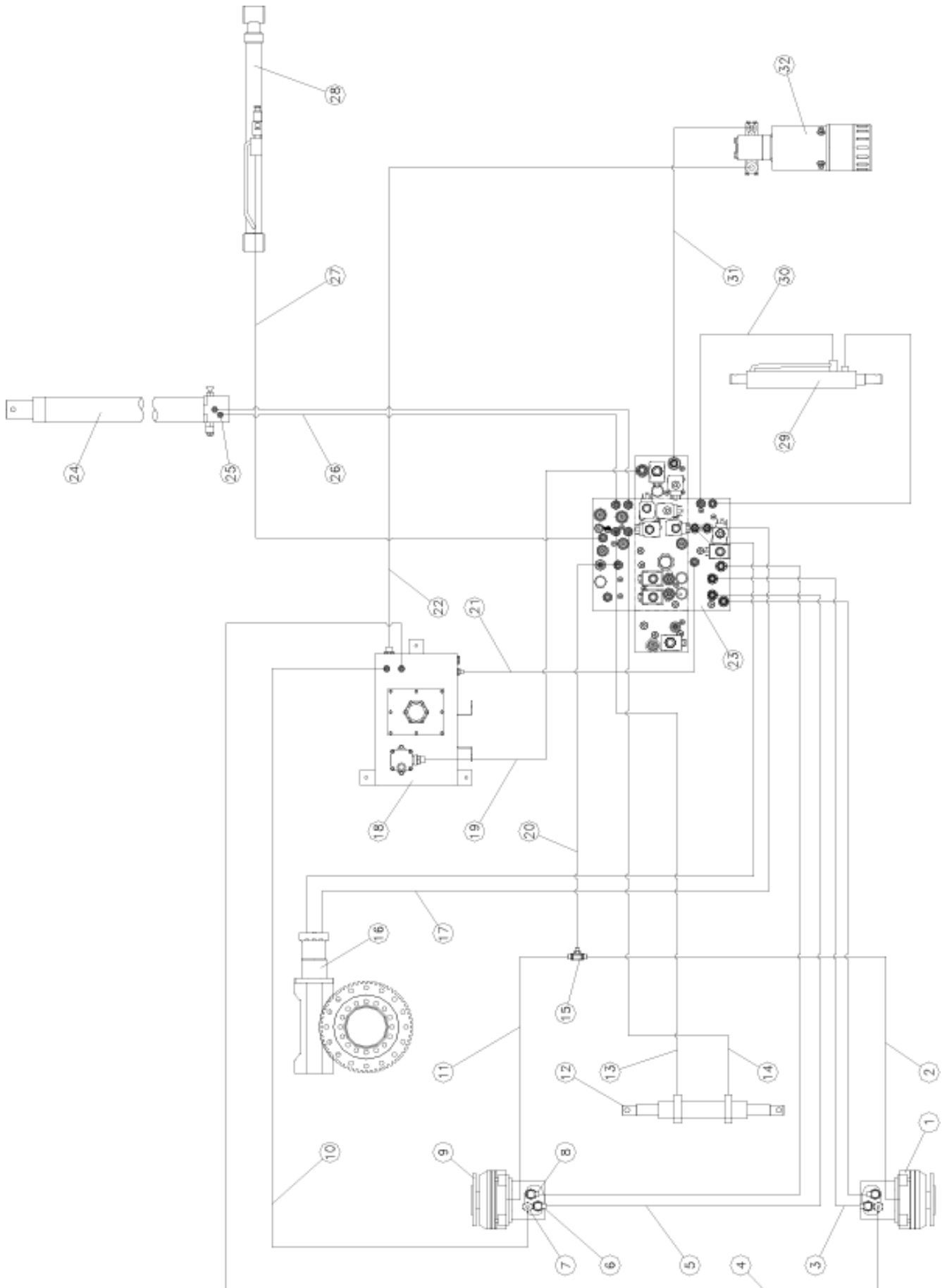

WATER FILL SYSTEM

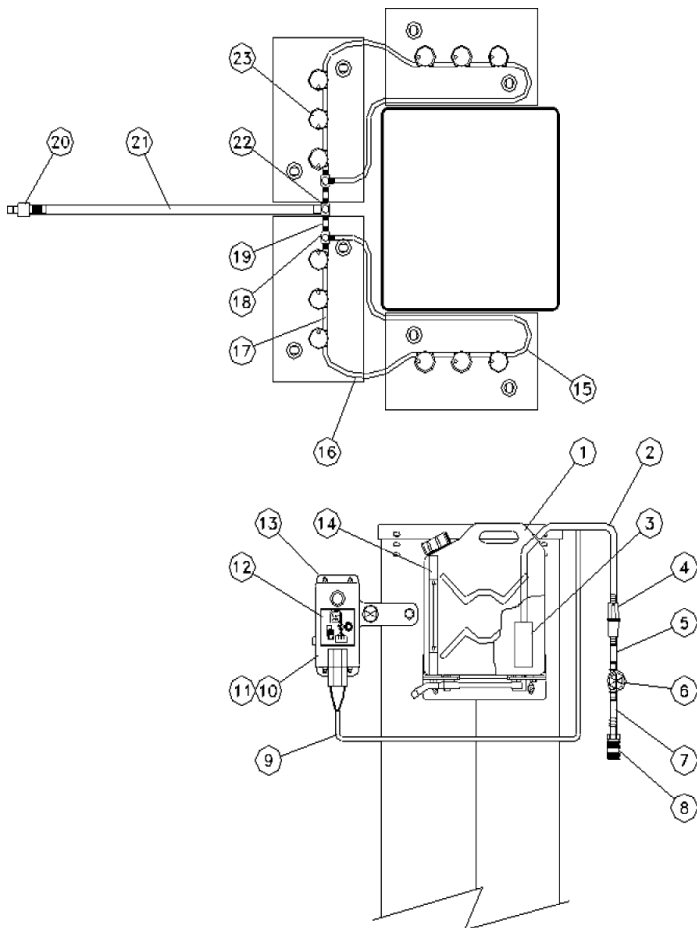

Item	Part No.	Description	Qty.
1	501624-000	BATTERY WATER CONTAINER	1
2	501630-000	PVC HOSE (10mm)	1
3	501632-000	SUBMERSIBLE PUMP	1
4	501627-000	BATTERY WATER REFILL	1
5	501666-000	PVC HOSE 10mm X30mm LG	1
6	501628-000	WATER FLOW INDICATOR	1
7	501631-000	PVC HOSE (10mm)	1
8	501629-000	FEMALE COUPLING (10mm)	1
9	501633-000	WIRING HARNESS (WATER PUMP)	1
10	501636-000	CONTROL BOX	1
11	501667-000	FUSE, CONTROL BOX	1
12	501643-000	OPERATING DECAL	1
13	501649-000	MOUNTING PLATE	1
14	501644-000	WATER FILL DECAL	1
15	501647-000	PVC HOSE 6mm X590mm LG	2
16	501646-000	PVC HOSE 6mm X230mm LG	2
17	501645-000	PVC HOSE 6mm X55mm LG	8
18	501641-000	T-PIECE 6 X6 X6	2
19	501648-000	PVC HOSE 6mm X30mm LG	4
20	501638-000	MALE COUPLING(10mm)	1
21	501639-000	PVC HOSE 10mm X545mm LG	1
22	501640-000	T-PIECE 10 X6 X6	1
23	501642-000	BATTERY FLOAT CAP	12
24	501590-000	FIXED ANGLE BRACKET	1
25	501588-000	MOUNTING ANGLE	1
26	501591-000	DRAW LATCH	1
27	501589-000	HINGE ANGLE BRACKET	1

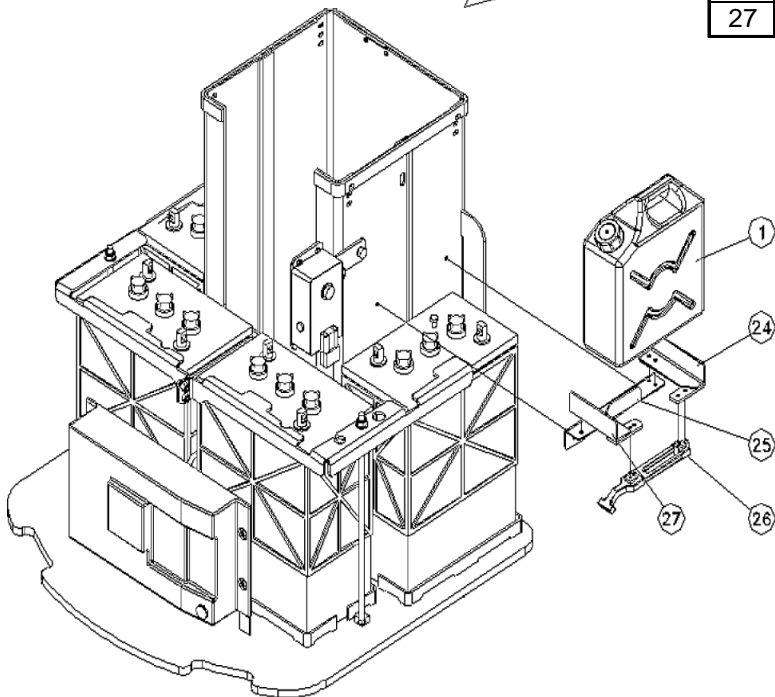

AUTOMATED TOP-UP SYSTEM 501652-000

Part No.	Description	Qty.
056057-025	M5 x 25mm Hex Head Bolt	3
056059-016	M8 x 16mm Set Screw	1
056066-004	M4 Nylock Nut	4
056066-006	M6 Nylock Nut	2
056066-008	M8 Nylock Nut	1
056069-006	M6 Plain Washer	2
058500-016	M4 x 16mm Skt Head Screw	4
501253-012	M6 x 12mm Skt Head Screw	4
501643-000	System Operating Decal	1
501644-000	Container Level Decal	1
501649-000	Water System Control	1
501651-000	Stick on Cable Tie	3
501888-000	B-FS Floats & Pipeing	1
501891-000	Battery Float Caps	12
508238-000	T-Piece	3
508239-000	Clear PVC Tubing	3.6
501890-000	Topping Bottle	1
501892-000	Control Box	1
508111-000	Shut-Off Valve	1

COVERS

Chassis Cover

MB26		Chassis Cover	
Item	Part No.	Description	Qty.
1	501202-003	Front Chassis Cover	1
2	500409-001	Captive Screw	2
3	500409-003	Captive Screw Recepticle	2
4	501202-002	Rear Chassis Cover	1
5	500465-001	Compression Latch	2
6	500259-001	Spur Washer	2
7	501348-000	Lift & Turn Latch	2

MB20N		Chassis Cover	
Item	Part No.	Description	Qty.
1	501202-001	Front Chassis Cover	1
2	500409-001	Captive Screw	2
3	500409-003	Captive Screw Recepticle	2
4	501202-000	Rear Chassis Cover	1
5	500465-001	Compression Latch	2
6	500259-001	Spur Washer	2
7	501348-000	Lift & Turn Latch	2

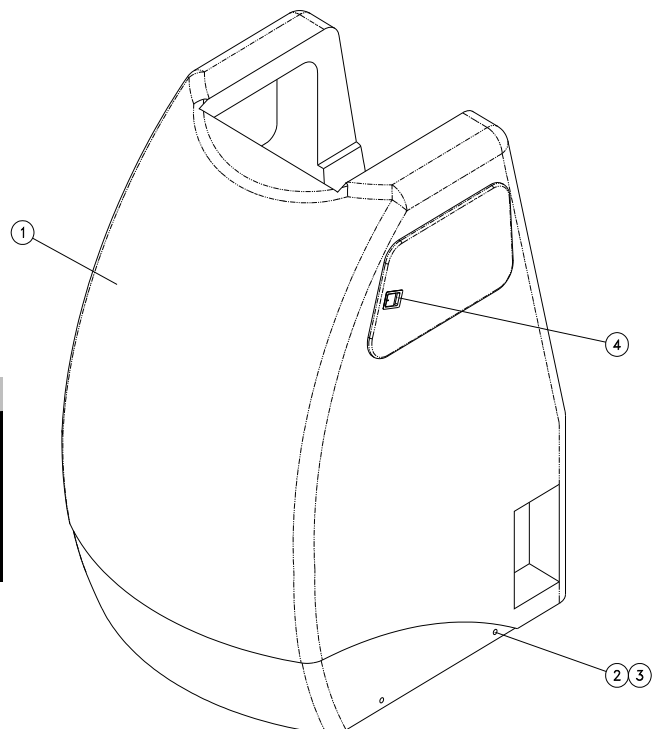
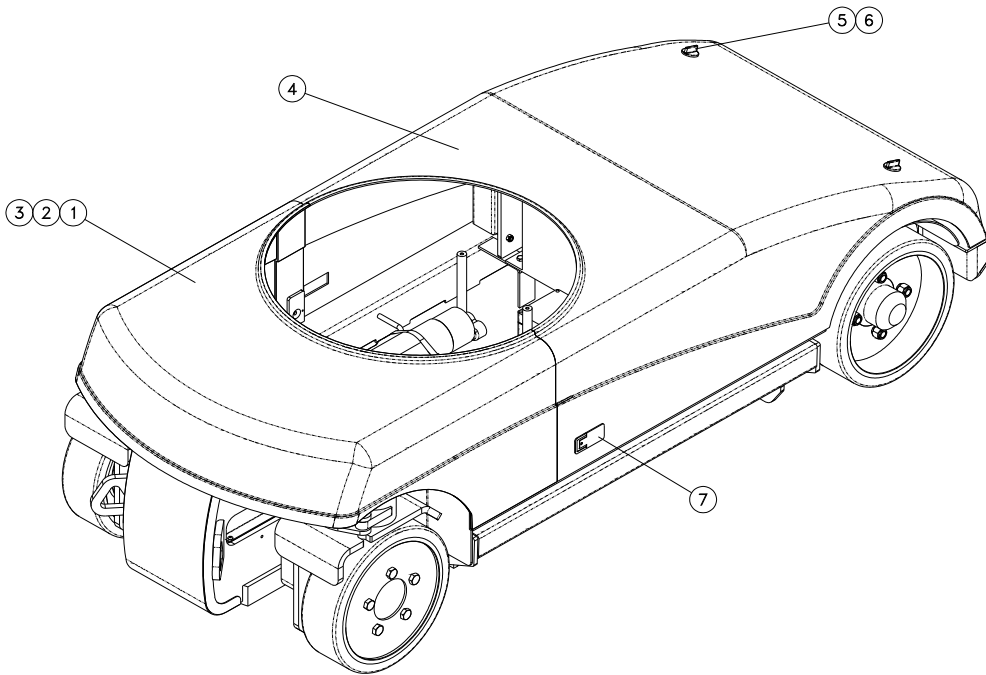

		Mast Cover	
Item	Part No.	Description	Qty.
1	501203-000	Mast Cover	1
2	501346-000	Captive Screw	4
3	501347-001	Captive Screw Recepticle	4
4		Slam Action Paddle Latch	2

MB26 DECALS

MB26 English (Euro)			
Item	Part No.	Description	Qty.
1	501345-001	MB26 Cage Decal	2
2	501343-001	MB26 Ballast Cover Decal	3
3	501344-000	Mast Boom Decal	3
4	057392-000	S.W.L. Large	1
5	501273-002	Name Plate	1
6	057382-000	Emergency Lowering	1
7	057429-000	Battery Fluid Level	2
8	057692-000	Important Before Using	1
9	501892-001	Upper Control Box	1
10	501573-000	Lower Control Box	1
11	058860-000	Pinch Point	3
12	057385-000	Hazard Tape	4
13	058181-000	Warning 3-point Decal	1
14	057430-000	Explosion Hazard	2
15	058186-000	EM. Down/Off/On	1
16	501375-001	Operators Manual	1
17	501376-001	Service & Parts Manual	1
18	501453-000	Pothole Crushing Hazard	3
19	501455-000	Mast Emergency Lowering	1
20	058531-000	Lift/Tow Point	4

MB26 English (USA)			
Item	Part No.	Description	Qty.
1	501345-001	MB26 Cage Decal	2
2	501343-001	MB26 Ballast Cover Decal	3
3	501344-000	Mast Boom Decal	3
4	058761-001	S.W.L. Large	1
5	501273-003	Name Plate	1
6	057382-000	Emergency Lowering	1
7	057429-000	Battery Fluid Level	2
8	058539-000	Important Before Using	1
9	501892-000	Upper Control Box	1
10	501573-000	Lower Control Box	1
11	058537-000	Pinch Point	1
12	057385-000	Hazard Tape	4
13	058181-000	Warning 3-point Decal	1
14	057430-000	Explosion Hazard	2
15	058186-000	EM. Down/Off/On	1
16	501375-001	Operators Manual	1
17	501376-001	Service & Parts Manual	1
18	501453-000	Pothole Crushing Hazard	3
19	501455-000	Mast Emergency Lowering	1
20	058531-000	Lift/Tow Point	4
21	058538-000	Hazards Decal	1
22	058532-000	Hydraulic Fluid	1
23	057426-000	Harness Attachment	1
24	058530-000	Meets ANSI 92.5	1
25	057425-001	Instructions Enclosed	1
26	057434-000	Only UpRight Components	1
27	057424-001	Crushing Hazard	2
28	058533-000	Do Not Adjust Switches	1
29	058534-000	Batteries are Ballast	2

MB26 French			
Item	Part No.	Description	Qty.
1	501345-001	MB26 Cage Decal	2
2	501343-001	MB26 Ballast Cover Decal	3
3	501344-000	Mast Boom Decal	3
4	057392-001	S.W.L. Large	1
5	501273-002	Name Plate	1
6	057382-001	Emergency Lowering	1
7	057429-001	Battery Fluid Level	2
8	057692-001	Important Before Using	1
9	501892-001	Upper Control Box	1
10	501573-000	Lower Control Box	1
11	058860-000	Pinch Point	3
12	057385-000	Hazard Tape	4
13	058181-001	Warning 3-point Decal	1
14	057430-001	Explosion Hazard	2
15	058186-001	EM. Down/Off/On	1
16	501375-001	Operators Manual	1
17	501376-001	Service & Parts Manual	1
18	501453-001	Pothole Crushing Hazard	3
19	501455-001	Mast Emergency Lowering	1
20	058531-000	Lift/Tow Point	4

MB26 German			
Item	Part No.	Description	Qty.
1	501345-001	MB26 Cage Decal	2
2	501343-001	MB26 Ballast Cover Decal	3
3	501344-000	Mast Boom Decal	3
4	057392-031	S.W.L. Large	1
5	501273-002	Name Plate	1
6	057382-002	Emergency Lowering	1
7	057429-024	Battery Fluid Level	2
8	057692-025	Important Before Using	1
9	501892-000	Upper Control Box	1
10	501573-000	Lower Control Box	1
11	058860-000	Pinch Point	3
12	057385-000	Hazard Tape	4
13	058181-002	Warning 3-point Decal	1
14	057430-026	Explosion Hazard	2
15	058186-002	EM. Down/Off/On	1
16	501375-001	Operators Manual	1
17	501376-001	Service & Parts Manual	1
18	501453-000	Pothole Crushing Hazard	3
19	501455-000	Mast Emergency Lowering	1
20	058531-000	Lift/Tow Point	4

MB20N DECALS

MB20N English (Euro)			
Item	Part No.	Description	Qty.
1	501345-000	MB20 Cage Decal	2
2	501343-000	MB20 Ballast Cover Decal	3
3	501344-000	Mast Boom Decal	3
4	057392-000	S.W.L. Large	1
5	501273-000	Name Plate	1
6	057382-000	Emergency Lowering	1
7	057429-000	Battery Fluid Level	2
8	057692-000	Important Before Using	1
9	501892-000	Upper Control Box	1
10	501573-000	Lower Control Box	1
11	058860-000	Pinch Point	3
12	057385-000	Hazard Tape	4
13	058181-000	Warning 3-point Decal	1
14	057430-000	Explosion Hazard	2
15	058186-000	EM. Down/Off/On	1
16	501375-001	Operators Manual	1
17	501376-001	Service & Parts Manual	1
18	501453-000	Pothole Crushing Hazard	3
19	501455-000	Mast Emergency Lowering	1
20	058531-000	Lift/Tow Point	4

MB20N English (USA)			
Item	Part No.	Description	Qty.
1	501345-000	MB20 Cage Decal	2
2	501343-000	MB20 Ballast Cover Decal	3
3	501344-000	Mast Boom Decal	3
4	058761-001	S.W.L. Large	1
5	501273-001	Name Plate	1
6	057382-000	Emergency Lowering	1
7	057429-000	Battery Fluid Level	2
8	058539-000	Important Before Using	1
9	501892-000	Upper Control Box	1
10	501573-000	Lower Control Box	1
11	058537-000	Pinch Point	1
12	057385-000	Hazard Tape	4
13	058181-000	Warning 3-point Decal	1
14	057430-000	Explosion Hazard	2
15	058186-000	EM. Down/Off/On	1
16	501375-001	Operators Manual	1
17	501376-001	Service & Parts Manual	1
18	501453-000	Pothole Crushing Hazard	3
19	501455-000	Mast Emergency Lowering	1
20	058531-000	Lift/Tow Point	4
21	058538-000	Hazards Decal	1
22	058532-000	Hydraulic Fluid	1
23	057426-000	Harness Attachment	1
24	058530-000	Meets ANSI 92.5	1
25	057425-001	Instructions Enclosed	1
26	057434-000	Only UpRight Components	1
27	057424-001	Crushing Hazard	2
28	058533-000	Do Not Adjust Switches	1
29	058534-000	Batteries are Ballast	2

MB20N French			
Item	Part No.	Description	Qty.
1	501345-001	MB20 Cage Decal	2
2	501343-000	MB20 Ballast Cover Decal	3
3	501344-000	Mast Boom Decal	3
4	057392-001	S.W.L. Large	1
5	501273-002	Name Plate	1
6	057382-001	Emergency Lowering	1
7	057429-001	Battery Fluid Level	2
8	057692-001	Important Before Using	1
9	501892-000	Upper Control Box	1
10	501573-000	Lower Control Box	1
11	058860-000	Pinch Point	3
12	057385-000	Hazard Tape	4
13	058181-001	Warning 3-point Decal	1
14	057430-001	Explosion Hazard	2
15	058186-001	EM. Down/Off/On	1
16	501375-001	Operators Manual	1
17	501376-001	Service & Parts Manual	1
18	501453-001	Pothole Crushing Hazard	3
19	501455-001	Mast Emergency Lowering	1
20	058531-000	Lift/Tow Point	4

MB20N German			
Item	Part No.	Description	Qty.
1	501345-000	MB20 Cage Decal	2
2	501343-000	MB20 Ballast Cover Decal	3
3	501344-000	Mast Boom Decal	3
4	057392-031	S.W.L. Large	1
5	501273-000	Name Plate	1
6	057382-002	Emergency Lowering	1
7	057429-024	Battery Fluid Level	2
8	057692-025	Important Before Using	1
9	501892-000	Upper Control Box	1
10	501573-000	Lower Control Box	1
11	058860-000	Pinch Point	3
12	057385-000	Hazard Tape	4
13	058181-002	Warning 3-point Decal	1
14	057430-026	Explosion Hazard	2
15	058186-002	EM. Down/Off/On	1
16	501375-001	Operators Manual	1
17	501376-001	Service & Parts Manual	1
18	501453-000	Pothole Crushing Hazard	3
19	501455-000	Mast Emergency Lowering	1
20	058531-000	Lift/Tow Point	4

DECALS

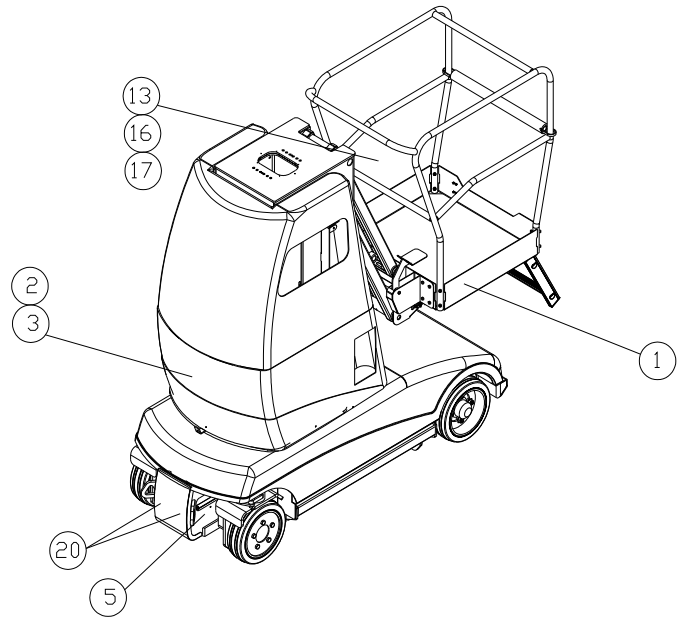
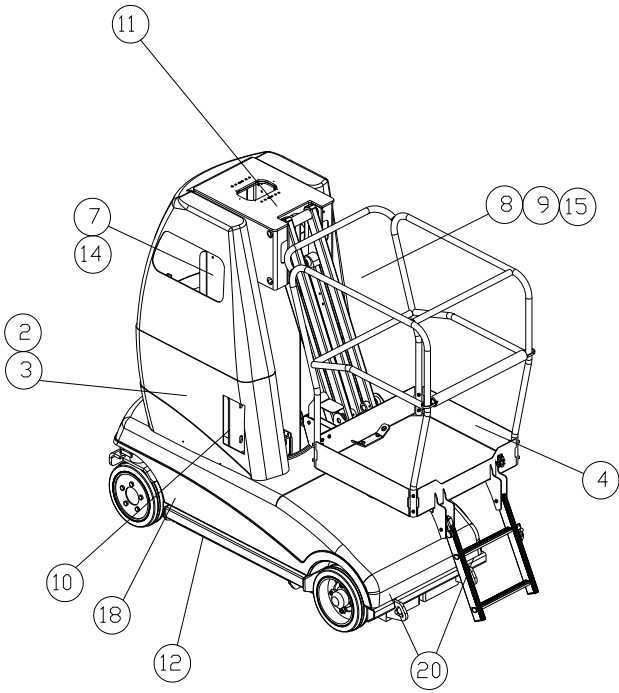
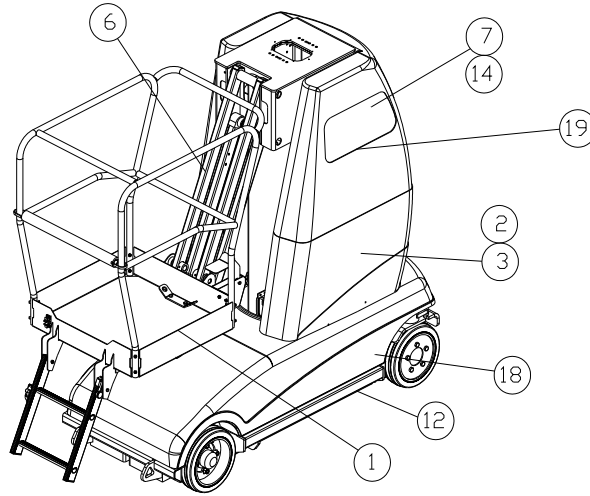

Local Distributor:

Distributeur local:

El Distribuidor local:

Snorkel International Inc.

P.O. Box 1160

St. Joseph, MO 64502-1160 USA

TEL: + 1-800-255-0317

Snorkel

www.snorkelusa.com

Serial number 501376-101