



TB80

TB85J



CE

# REPAIR PARTS MANUAL

Fixed Axle  
Serial number 110811047 and after

Models TB80/TB85J/T80/T85J  
Replaces 0112950 March 2014

Part Number 0112950  
August 2014

# DANGER

**The aerial platform is not electrically insulated. Death or serious injury will result from contact with, or inadequate clearance from, an energized conductor.**

**Do not go closer than the Minimum Safe Approach Distance as defined by ANSI standards.**

Regard all conductors as energized.

Allow for electrical wire sag and aerial platform sway.

If the platform, boom structure, or any part of the aerial platform contacts a high-voltage electrical conductor, the entire machine can become electrically charged.

If that happens, remain on the machine and do not contact any other structure or object. This includes the ground, adjacent buildings, poles, and any other objects that are not part of the aerial platform.

Such contact could make your body a conductor to the other object, creating an electrical shock hazard resulting in death or serious injury.

If an aerial platform is in contact with an energized conductor the platform operator must warn ground personnel in the vicinity to stay away. Their bodies can conduct electricity creating an electrical shock hazard resulting in death or serious injury.

Do not approach or leave the aerial platform until the electricity has been turned off.

Do not attempt to operate the lower controls when the platform, scissors structure, or any part of the aerial platform is in contact with a high-voltage electrical conductor or if there is an immediate danger of such contact.

Personnel on or near an aerial platform must be continuously aware of electrical hazards, recognizing that death or serious injury can result from contact with an energized conductor.

## California

### Proposition 65 Warning

Battery posts, terminals and related accessories contain lead and lead components, chemicals known to the State of California to cause cancer and birth defects or other reproductive harm. Wash hands after handling.

## California

### Proposition 65 Warning

Diesel and gasoline engine exhaust and some of its constituents are known by the State of California to cause cancer, birth defects or other reproductive harm.

# Table of Contents

Electrical Hazard .....	Inside front cover
California Proposition 65 .....	Inside front cover

## General Information

About This Manual.....	i
Repairs and Maintenance.....	i
Abbreviations.....	i
Additional Information.....	i

## Service and Parts Information

Ordering Parts.....	ii
ANSI and OSHA Compliance.....	ii
Manuals.....	ii
Machine Information.....	ii
Parts Order Form.....	iii

## Section 1 – Repair Parts

Chassis, Drive .....	3
Steering .....	7
Lift and Swing .....	11
Swing Drive Assembly – Perfection Gear .....	15
Fuel Tank .....	17
Hydraulic Oil Reservoir Mounting .....	19
Booms, Base End .....	21
Boom Installation – TB80 .....	25
Boom Installation – TB85J .....	29
Boom Installation – CE .....	33
Boom and Hose Carrier – TB80 .....	37
Boom and Hose Carrier – TB85J .....	41
Boom and Hose Carrier – CE.....	45
Hose Carrier Assembly – TB80 .....	49
Hose Carrier Assembly – TB85J .....	53
Jib – TB85J – Before 11/2007 .....	57
Jib – Platform Rotator – Before 11/2007 .....	58.1
Jib – Inner Quadrant – Before 11/2007 .....	58.1
Jib – TB85J – After 10/2007 .....	59
Jib – Platform Rotator – After 10/2007 .....	60.1
Jib – Inner Quadrant – After 10/2007 .....	60.1
Extend Cylinder Mounting .....	61
Platform Mounting – TB80 .....	65
Platform Gate .....	67
Platform Rotator – TB80 .....	69
Engine Mounting – Cummins 3.3 .....	71
Radiator – Cummins 3.3 .....	75
Engine with Radiator – Cummins 3.3 .....	79
Engine Tray – Cummins 3.3 .....	83
Engine Mounting – Deutz .....	87
Engine – Deutz .....	91
Exhaust and Air Cleaner – Deutz .....	95
Engine Mounting – GM .....	97
Engine – GM .....	101
Exhaust and Air Cleaner .....	105
Cowling .....	107
Placards and Decals .....	111
Gear Hub – Auburn Gear .....	117
Swing Drive – Perfection Gear .....	119
Tires and Wheels .....	121

## Section 2 – Hydraulics

Chassis Hydraulics .....	3
Turntable Hydraulics .....	7
Hydraulic Oil Reservoir .....	11
Proportional Control Valve .....	13
Non-Proportional Control Valve .....	17
AC Generator Valve .....	21
Centerpost .....	23
Cylinder, Extension – GBI .....	25
Cylinder, Lift .....	27
Cylinder, Lift – Rosenboom .....	29
Cylinder, Master Level .....	31
Cylinder, Slave Level .....	33
Cylinder, Steering .....	35
Cylinder, Jib .....	37
Emergency Power Unit .....	39
Hydraulic Pump and Fittings .....	41
Sense Line Dump Valve .....	43
Hydraulic Warm Up Valve .....	45
Motion Control Valve, Drive .....	47
Motion Control Valve, Turntable Swing .....	49
Pressure Manifold .....	51
Four Wheel Steer Valve .....	53
Speed Shift Valve .....	55
Oil Return Filter .....	57
Front Transmission Valve .....	59
Rear Transmission Valve .....	61
Chassis Accumlator .....	63

## Section 3 – Electrical

Turntable Electrical, Cummins – TB80 .....	3
Turntable Electrical, Deutz – TB80 .....	9
Turntable Electrical, Cummins – TB85J .....	15
Turntable Electrical, Deutz – TB85J .....	21
Turntable Electrical, GM – TB85J .....	27
Turntable Electrical, CE – TB85J .....	33
Main Boom Electrical – TB80 .....	39
Main Boom Electrical – TB85J .....	45
Main Boom Electrical – CE .....	51
Lower Controls – TB80 .....	57
Lower Controls, Cummins – TB80 .....	61
Lower Controls, Deutz – TB80 .....	63
Lower Controls – TB85J .....	65
Lower Controls, Cummins – TB85J .....	69
Lower Controls, Deutz – TB85J .....	71
Lower Controls, GM – TB85J .....	73
Lower Controls, CE – TB85J .....	77
Wiring Box Assembly – Cummins, Deutz and CE ..	81
Wiring Box Assembly – GM .....	85
Wiring Box Panel – Cummins, Deutz and CE .....	89
Wiring Box Panel – GM .....	93
Turntable Harness Assembly .....	97
Upper Control Panel – TB80 .....	101
Upper Control Panel – TB85J .....	105
Upper Control Panel – CE .....	109
Platform Foot Switch .....	115

Boom Switch .....	117
Boom Extend Switch .....	119
Controller, Drive/Steer .....	121
Controller, Lift/Swing .....	123
Controller, Extend/Retract .....	125
GFCI 110 Volt Power .....	127

#### **Section 4 – Options**

Dual Fuel .....	3
LP Fuel Only .....	5
Gasoline Only .....	7
110 V AC Generator Mounting .....	9
110 V AC Generator .....	11
220 V AC Generator Mounting .....	13
220 V AC Generator .....	15
AC Generator Valve .....	17
12 kw Generator .....	19
Platform Welder – Aluminum Platform .....	21
Platform Welder – Steel Platform .....	23
Work Lights – Halogen or Incandescent .....	25
Air Inlet Heater – Deutz .....	27
Motion Alarm, All Motion .....	29
Airline to Platform .....	31
Tilt Alarm Light .....	33
Headlights and Taillights .....	35

Walk-through Gate .....	39
Gravity Gate .....	41
Spark Arrestor – Deutz Engines Only .....	43
Dual Flashing Light, Amber or Red .....	45
Drive Motion Alarm .....	47
Platform Control Cover .....	49
Isolation Valve .....	51
Sandblast Kit .....	53
Hydraulic Warm Up .....	55
Four Halogen Lights .....	57

#### **Section 5 – Maintenance**

Maintenance .....	3
Daily Prestart Inspection.....	5
Frequent Inspection and Maintenance .....	7
Frequent Maintenance.....	11
Annual Maintenance.....	13
Major Repairs .....	15
Lubrication Points.....	17
Fastener Torque Chart.....	21

#### **Appendix**

Electrical Schematics
Hydraulic Schematics

#### **Limited Warranty**

# General Information

## About This Manual

This manual covers TB80 and TB85J aerial platforms. Information is included for machines that have been manufactured to conform to all applicable requirements of the following organizations:

- American National Standards Institute (ANSI)
- Canadian Standards Association (CSA)
- European Committee for Standardization (CE)

Part pages include a drawing and a bill of material. The bill of material lists the item number that is on the drawing, the Snorkel part number, quantity used and a description of the item.

Some callouts in the drawings may have a balloon with two numbers. The top number is the item number and the bottom number is the quantity of the item at that location.

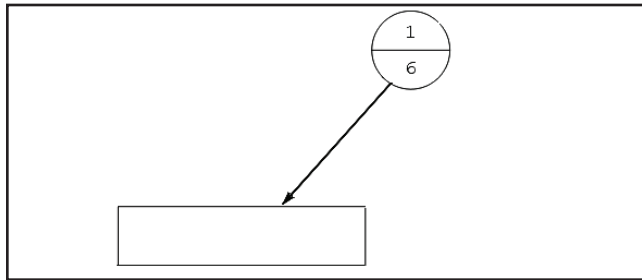

While Snorkel has attempted in every way to confirm that all information in this manual is correct, improvements are being constantly made to the machine that may not be reflected in this manual.

If you find information in this manual that is not correct or is confusing, you are urged to report your findings to Snorkel for our evaluation. Your input is important to us and will be used in future printings of this manual.

This machine is covered by a limited warranty that specifically identifies items warrantied by Snorkel and those items covered by original manufacturer's warranty. A copy of the Snorkel Limited Warranty is located on the inside of the back cover of this manual.

## Repairs and Maintenance

Every person who maintains, inspects, tests or repairs the machine must be qualified and authorized to do so.

### Caution

**Do not modify this aerial platform without prior written consent of Snorkel Engineering Department. Modification may void the warranty, adversely affect stability or affect the operational characteristics of the aerial platform.**

## Abbreviations

The following abbreviations may be used in this manual.

AC	alternating current
ANSI	American National Standards Institute
AR	as required
CCA	cold cranking amps
cm	centimeter
DC	direct current
ft	feet
GFCI	ground fault circuit interruptor
in	inch
lbs	pounds
mm	millimeter
no	number
NPT	national pipe thread
psi	pounds per square inch
qty	quantity
rpm	revolutions per minute
UL	Underwriters Laboratories Inc.

## Additional Information

All correspondence relative to this machine, such as field reports, discrepancy reports, requests for information, etc., should be directed to:

Snorkel International, Inc.  
P.O. Box 1160  
St. Joseph, MO 64502-1160 USA  
Phone: 1-800-255-0317

<http://www.snorkelusa.com>

# Service and Parts Information

## Ordering Parts

When placing an order for service or repair parts, please have the following machine information readily available.

- Model number
- Serial number
- Snorkel part number
- Description of part
- Quantity of parts required
- Your purchase order number
- Address for order to ship to
- The desired shipment method

The parts order form on the following page may be mailed or faxed to the attention of the Parts Department at the following location:

Snorkel International, Inc.  
P.O. Box 1160  
St. Joseph, MO 64502-1160 USA

Phone: 1-800-255-0317  
Parts Fax: 1-785-989-3077

Attention: Parts Department

For your convenience, our electronic on-line ordering system is available at the following Internet location:

<http://www.snorkelusa.com>

## ANSI and OSHA Compliance

All owners and users of the aerial platform must read, understand and comply with all applicable regulations. Ultimate compliance to OSHA regulations is the responsibility of the user and their employer.

ANSI publications clearly identify the responsibilities of all personnel who may be involved with the aerial platform. A reprint of the "Manual of Responsibilities for Dealers, Owners, Users, Operators, Lessors and Lessees of ANSI/SIA A92.5-2006 Boom-Supported Elevating Work Platforms" is available from Snorkel dealers or from the factory upon request.

Copies are also available from:

Scaffold Industry Association, Inc.  
P.O. Box 20574  
Phoenix, AZ 85036-0574 USA

## Manuals

Manuals are available from Snorkel to support any of the machines that we produce.

The specific manuals for TB80 and TB85J aerial platforms are as follows:

**TB80/TB85J – Fixed Axle Operator’s Manual**  
Snorkel part number – 0112792

**TB80/TB85J – Fixed Axle Operator’s Manual CE**  
Snorkel part number – 0112823EE

**TB80/TB85J – Fixed Axle Repair Parts Manual**  
Snorkel part number – 0112950

**ANSI Manual of Responsibilities**  
ANSI/SIA A92.5-2006  
Snorkel part number – 0084053

## Machine Information

Model Number: \_\_\_\_\_

Serial Number: \_\_\_\_\_

Date of Purchase: \_\_\_\_\_

Purchased From: \_\_\_\_\_

Snorkel Dealer or Distributor: \_\_\_\_\_

\_\_\_\_\_

\_\_\_\_\_

## Parts Order Form

Fill out completely and fax to 1-785-989-3077, attention Parts Department.

Date: \_\_\_\_\_

Account Number: \_\_\_\_\_

Company: \_\_\_\_\_

Purchase Order Number: \_\_\_\_\_

Address: \_\_\_\_\_

Model Number: \_\_\_\_\_

\_\_\_\_\_

Serial Number: \_\_\_\_\_

\_\_\_\_\_

Ship To: \_\_\_\_\_

Contact Name: \_\_\_\_\_

\_\_\_\_\_

Phone Number: \_\_\_\_\_

\_\_\_\_\_

Fax Number: \_\_\_\_\_

\_\_\_\_\_

Shipping Method: \_\_\_\_\_

Part Number	Description	Quantity

Note: Backordered parts will be shipped as soon as available using the same shipping method as the original order unless otherwise indicated below.

- Ship complete order only. Do not backorder parts.
- Ship all available parts and disposition of backordered parts.
- Other instructions as specified: \_\_\_\_\_  
\_\_\_\_\_





# *Repair Parts*

TB80

TB85J



 **snorkel**



F

E

D

C

B

A

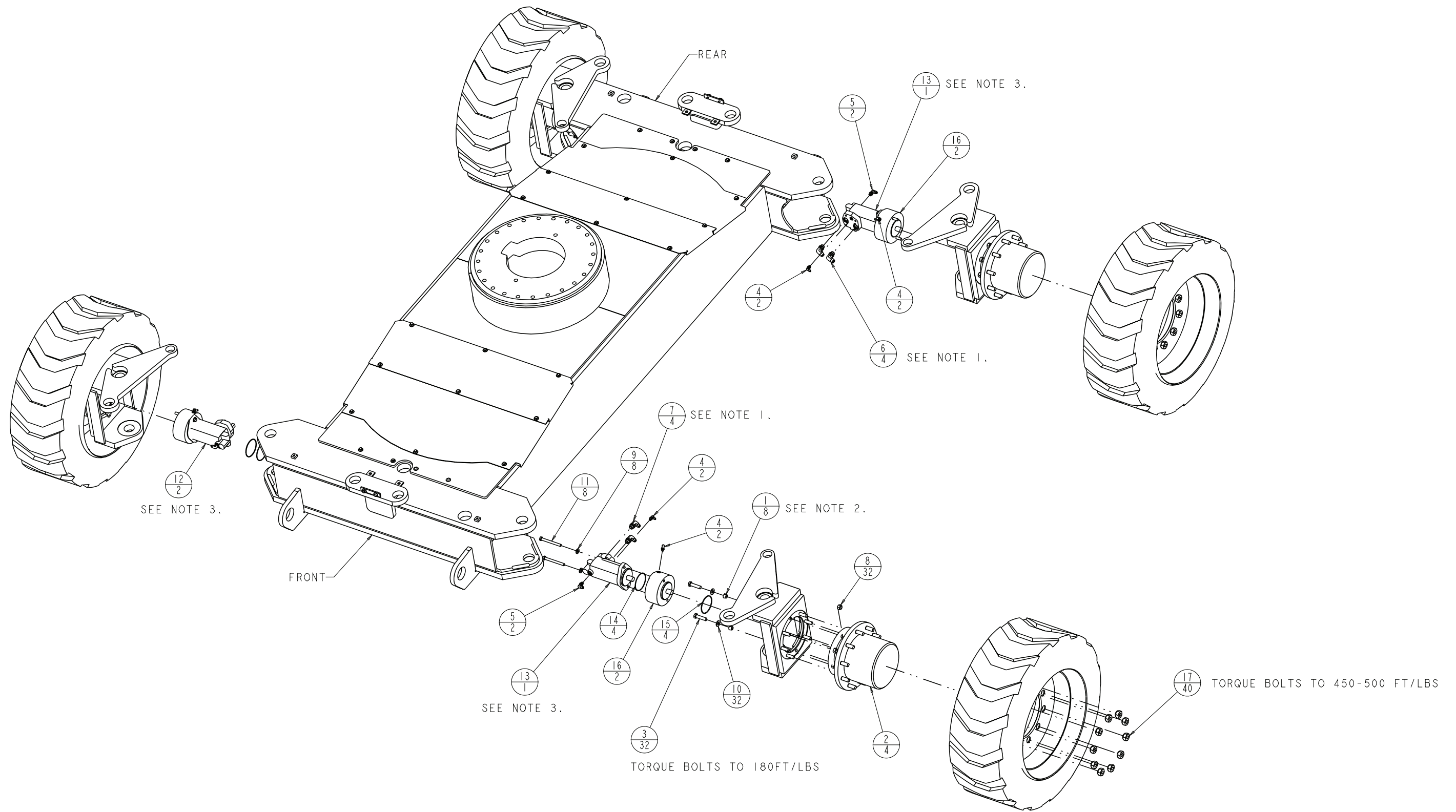

- NOTES:
1. 5035316 TO BE USED ON FRONT DRIVE MOTORS,  
5035307 TO BE USED ON REAR DRIVE MOTORS.
  2. INSTALL 0111675 IN TOP AND BOTTOM BOLT HOLES  
IN YOKE.
  3. 6031617 TO BE USED ON RIGHT SIDE OF MACHINE,  
6031618 TO BE USED ON LEFT SIDE OF MACHINE.

1

2

3

4

5

6

7

8

9

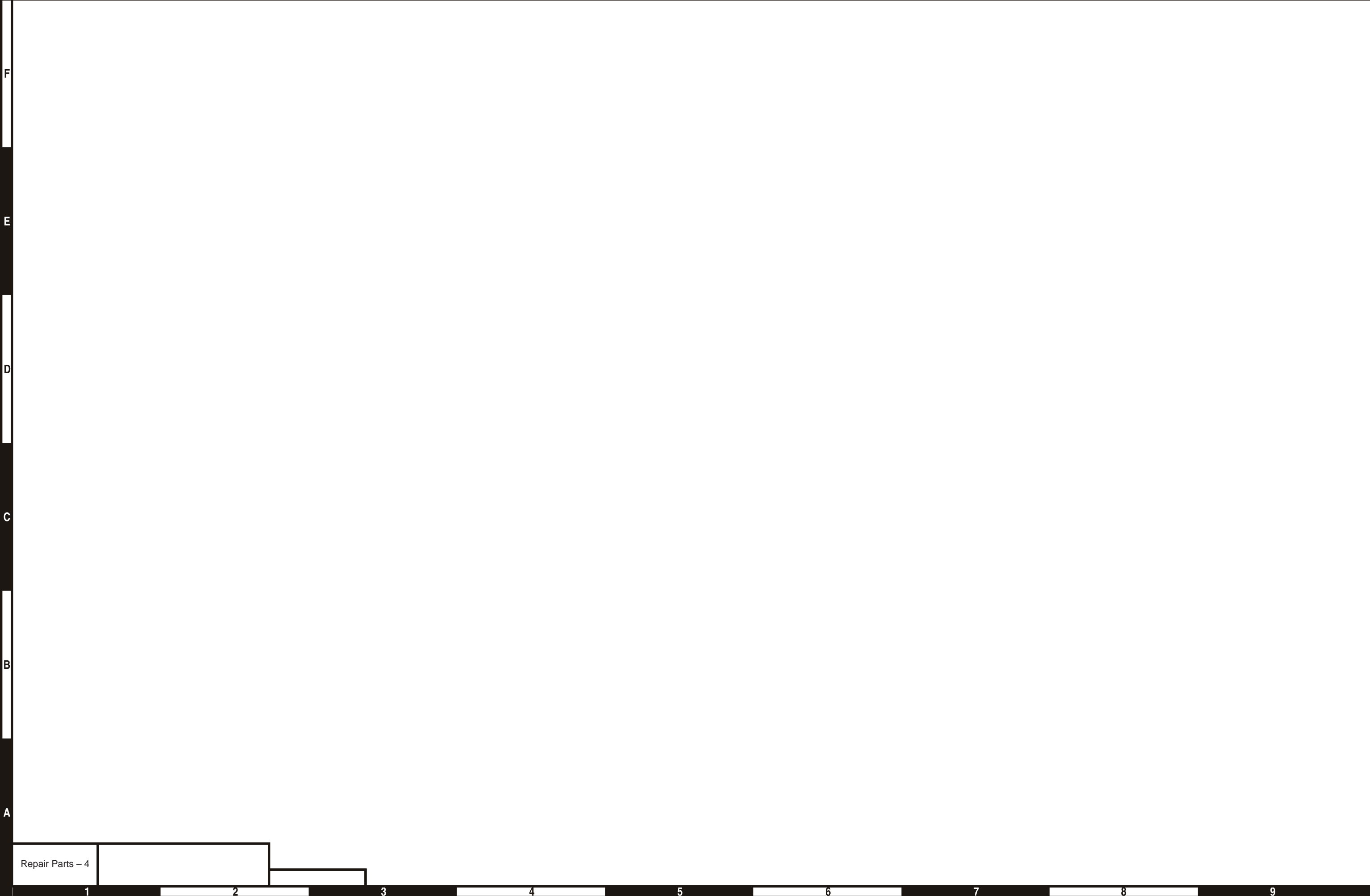

F

E

D

C

B

A

Repair Parts - 4

1

2

3

4

5

6

7

8

9

## Chassis, Drive

Item	Part No.	Qty.	Description
1	0111675	8	WEDGE, STUD
2	0180961	4	GEAR HUB
3	971329	32	BLT .625-11 2.50
4	5035303	8	FTG ELB90STRHD - 4B - 4S - STL
5	5035305	4	FTG ELB90STRHD - 6B - 6S - STL
6	5035307	4	FTG ELB90STRHD - 10B - 10S - STL
7	5035316	4	FTG ELB90STRHD - 10B - 8S - STL
8	5560131	32	NUT LKG .625-11 HIGH STRENGTHH
9	5560168	8	WSHR HARD FLAT .500 SP
10	5560169	32	WSHR HARD FLAT .625 SP
11	5560343	8	BLT .500-13 5.00 SP
12	6031617	2	MOTOR, HYDRAULIC 602 CU. IN. RH
13	6031618	2	MOTOR, HYDRAULIC 602 CU. IN. LH
14	7110155	4	O-RING
15	7110242	4	O-RING
16	7200024	4	BRAKE UNIT MICO
17	7280010	40	NUT, LUG 3/4 - 16 RH HEX

## Chassis, Drive



F

E

D

C

B

A

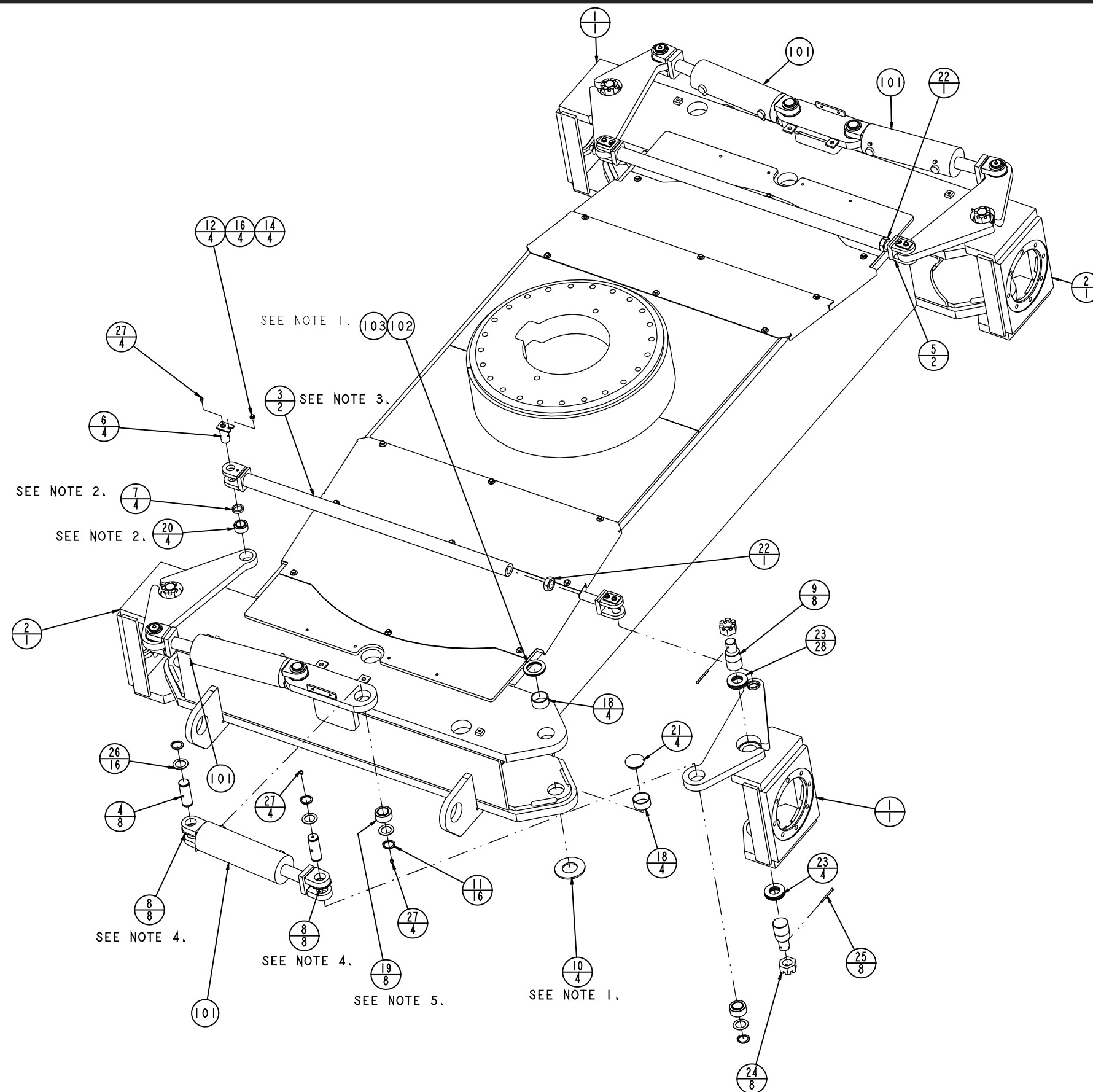

NOTES:

1. JACK UP YOKE AND INSTALL SHIMS TOP AND BOTTOM TO PROVIDE .005/.010 CLEARNCE FOR TOP
2. INSTALL BUSHING TO ALLOW 0112661 TO BE ABOVE YOKE PLATE TOP SURFACE.
3. ADJUST TIE ROD FOR 0" TOE IN.
4. USE AS REQUIRED TO LEVEL CYL. 1 PER CYL. MIN.
5. APPLY LOCTITE 60931 RETAINING COMPOUND AS REQUIRED.

TORQUE BOLTS TO 600FT/LBS

1

2

3

4

5

6

7

8

9

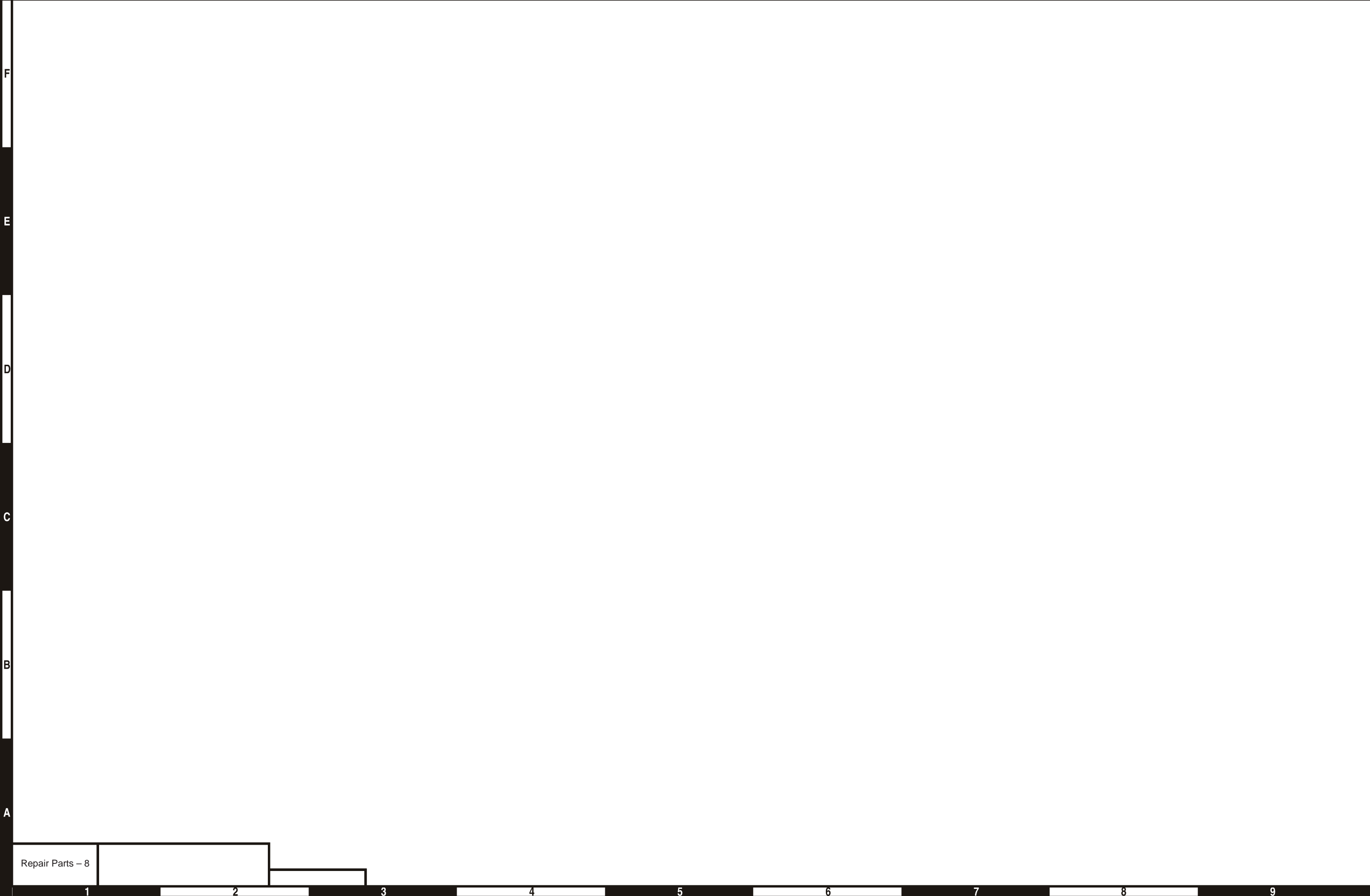

F

E

D

C

B

A

Repair Parts – 8

1

2

3

4

5

6

7

8

9



## Steering

Item	Part No.	Qty.	Description
1	0112642	2	WLDMT, STEERING YOKE RH
2	0112660	2	WLDMT, STEERING YOKE LH
3	0112661	2	WLDMT, TIE ROD 53.50
4	0112780	8	PIN, STR CYL 1.50
5	0112787	2	WLDMT, TIE ROD ADJUSTABLE END
5	5560202	2	NUT HEX JAM 1.250-12 GR8
6	0112789	4	WLDMT, TIE ROD PIN
7	0112791	4	SPCR 1.28ID 1.66OD .36
8	0112793	20	SPCR 1.78ID 3.00OD 20GA
9	0190715	8	PIN KING FR WHL DR
10	0190788	4	BRG THR 2.25ID 4.50OD .250 SP
11	302323	16	SNAPRING 1.50 HD
12	970029	4	BLT .25-20 .750 GR5
13	970449	18	BLT .375-16 .750 GR5
14	986019	4	WSHR FLAT .250
15	986299	18	WSHR FLAT .38
16	987099	4	WSHR LOCK .250
17	987119	18	WSHR LOCK .375
18	2503620	8	BRG 2.25ID 2.50OD 1.25
19	2690008	8	BRG SPHER 1.50ID
20	2691526	4	BRG SPHER 1.25ID
21	5070026	4	DUST CAP
22	5560202	2	NUT JAM .750-10
23	5560232	32	WSHR FLAT HARD 1.63 SP
24	5560241	8	NUT HEX SLTD 1.50-12
25	5560402	8	PIN COT .250 DIA 2.50
26	5560688	16	BSHG MCHRY 1.50ID 2.25OD .075
27	5570001	12	GREASE FTG 1/8-24 NPT STR
101	0112777	4	CYL 4.00 X 8.75
102	5569854	AR	BSHG MCHRY 2.25 ID 3.25 OD 14GA
103	5560717	AR	BSHG MCHRY 2.25 ID 3.25 OD 10GA

## Steering



F

E

D

C

B

A

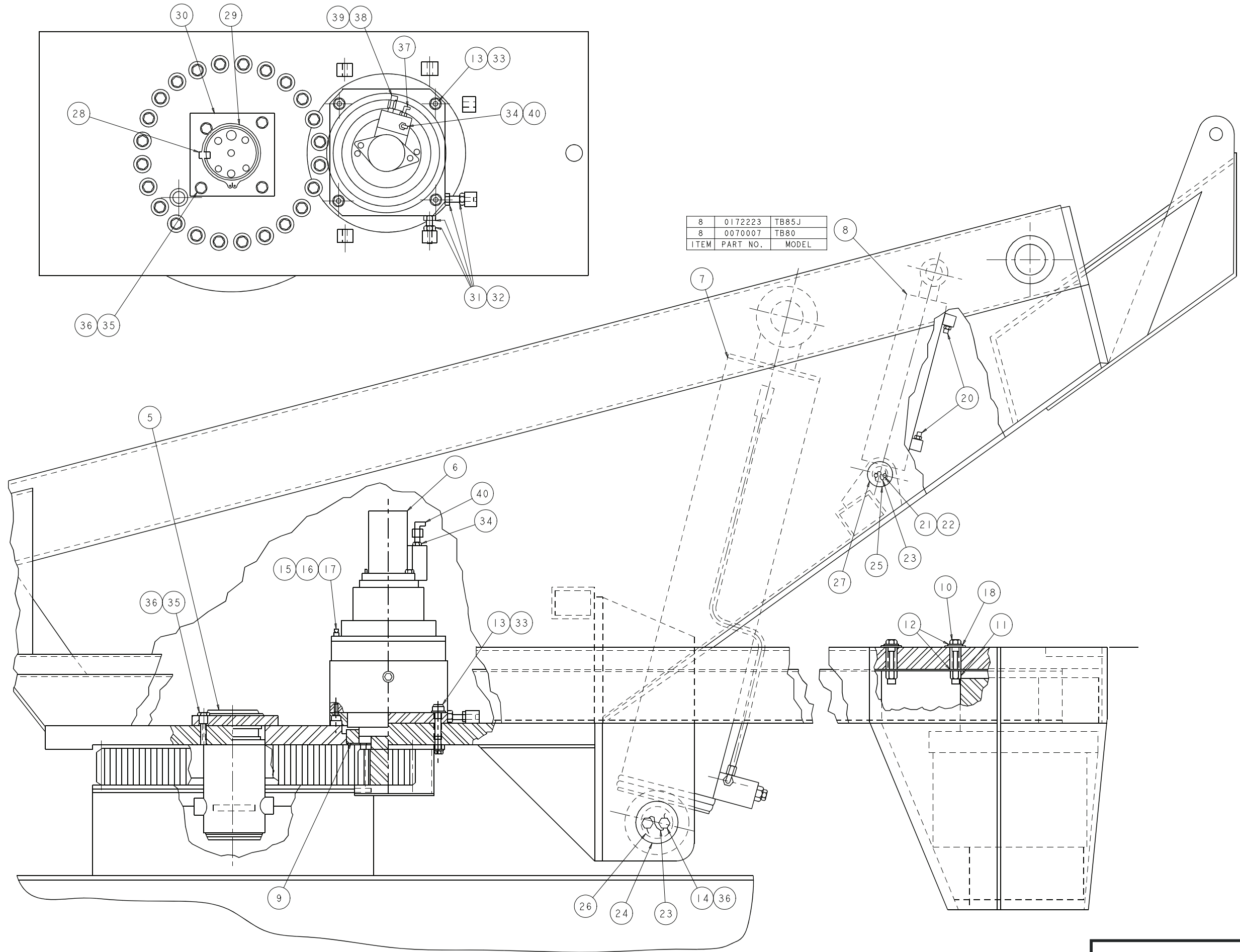

A11054B

Lift and Swing

Repair Parts - 11

1

2

3

4

5

6

7

8

9

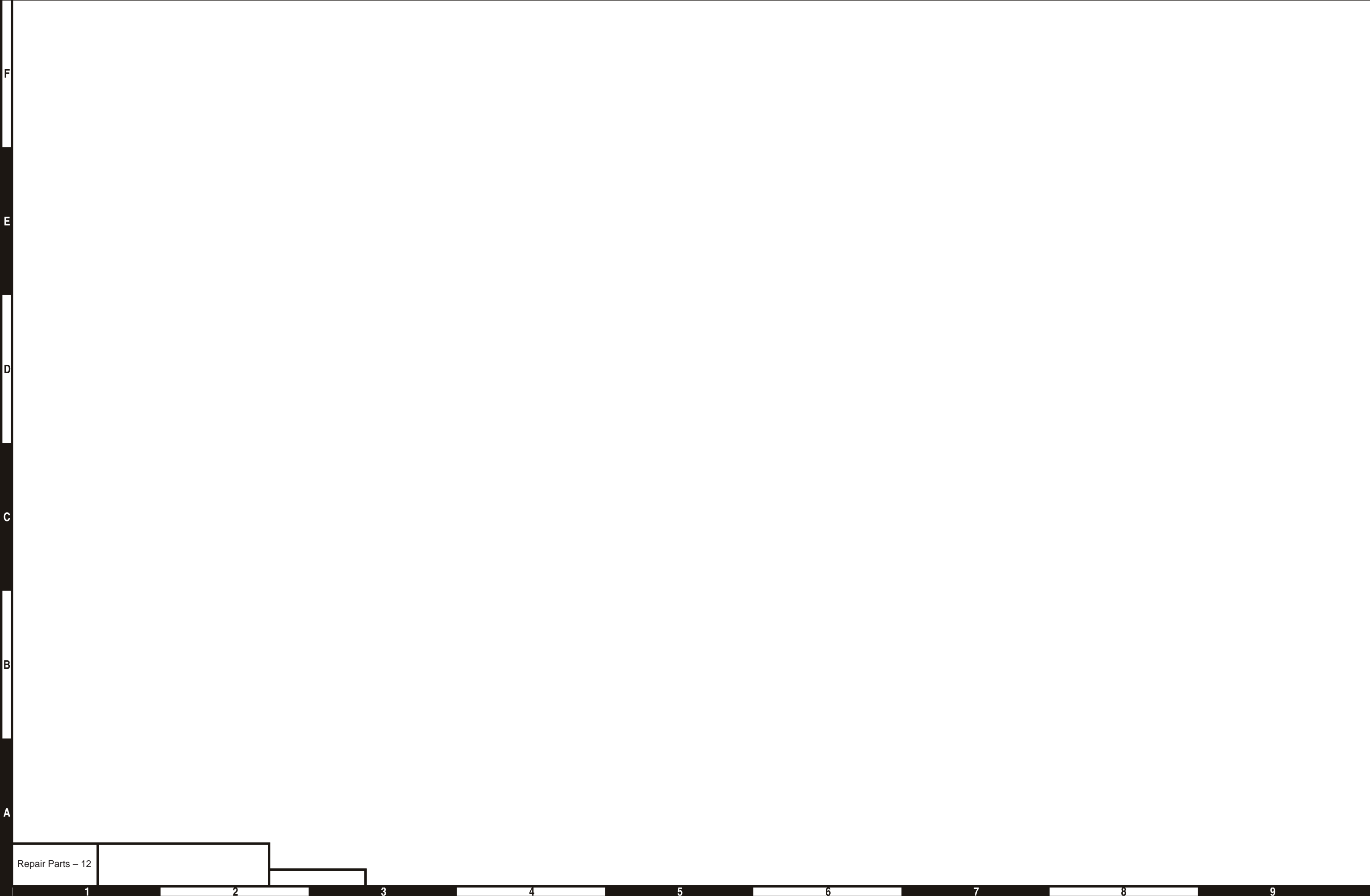

F

E

D

C

B

A

Repair Parts – 12

1

2

3

4

5

6

7

8

9

## Lift and Swing

Item	Part No.	Qty.	Description
5	0112747	1	CENTERPOST AND FITTING SUB-ASSY
6	0110837	1	SWING DRIVE MTR/BRK ASSY
7	0110168	1	LIFT CYLINDER AND TUBE SUB-ASSY
8	0074799	1	LEVELING CYLINDER ASSY – TB80 ONLY
	0172223	1	LEVELING CYLINDER ASSY – TB85J ONLY
9	0110942	1	ADJUSTMENT RING
10	971379	4	CAPSCREW 5/8-11 NC X 3-3/4 HH GR8
11	5560036	4	NUT 5/8-11 ESNA
12	5560678		FLATWASHER 5/8 – USE TO SHIM COUNTERWEIGHT FLUSH WITH SIDE RAILS
13	986459	4	FLATWASHER 3/4 HARDENED ASTM F-436
14	0110681	2	DRILL HD BLT 5/8-11 NC X 1-1/4 LG
15	7720201	1	REDUCING BUSHING (1/4 - 1/8)
16			AIR VENT
17	7720302	1	REDUCER BUCHING (3/8 - 1/4)
18	5560678	4	FLATWASHER 5/8 HARDENED ASTMF-436
20	5065707	2	ADAPTER STRAIGHT THREAD -6
21	0070473	2	DRILLED HD BLT 5/16-18 NC X 3/4 LG
22	987109	2	LOCK WASHER 5/16 MD
23	9980012		.040 Ø S.S. WIRE
24	0110234	1	PIN LOCK
25	0070033	1	PIN LOCK
26	0110341	1	PIN LIFT CYL TO TURNTABLE
27	0070442	1	PIN LEVELING CYL TO TURNTABLE
28	0070472	1	KEY
29	5590003	2	RETAINING RING
30	0070256	1	ADAPTER PLATE
31	5560022	6	ADJUSTMENT BOLT
32	984449	6	JAM NUT 5/8 - 11 NC HEX
33	5560100	4	BLT SELF LOCKING HEX SOCKET HD.
34	5065703	1	STR THD ADAPTER -4
35	5560051	4	BLT SELF LOCKING HEX SOCKET HD.
36	987159	6	LOCKWASHER 5/8 MED
37	5035306	1	ELBOW-STR THREAD -8-8
38	5065709	1	ADAPTER STR. THREAD -8-8
39	5037006	1	ELBOW-SWIVEL NUT -8
40	5037003	1	ELBOW 90° STR THREAD -4

## Lift and Swing



# Swing Drive Assembly – Perfection Gear

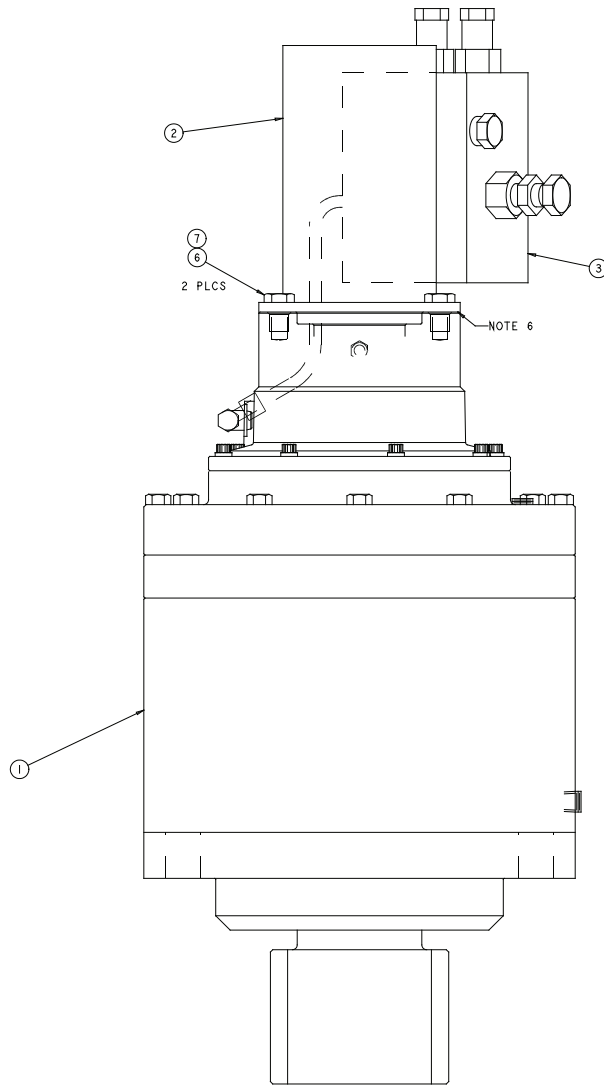

6. PAPER GASKETS NOT APPROVED. USE LOCTITE INSTANT GASKET 30509 OR APPROVED EQUIVALENT

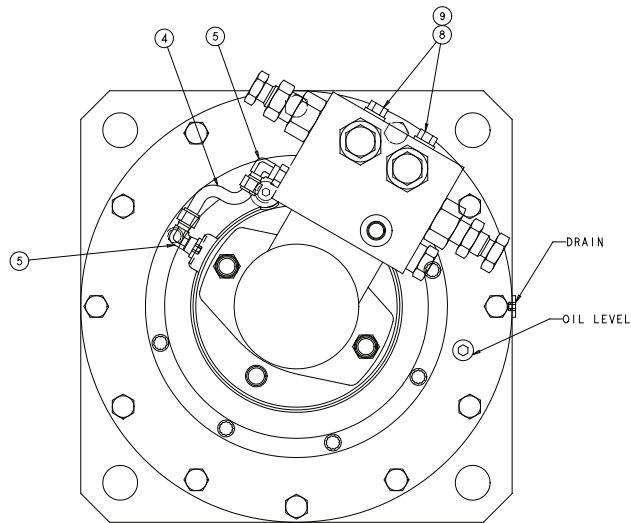

TOP VIEW

0110837

# Swing Drive Assembly – Perfection Gear

## Swing Drive Assembly – Perfection Gear

Item	Part No.	Qty.	Description
1	0110837	1	PLANETARY SWING DRIVE
2	6030017	1	MOTOR, SWING DRIVE
3	6010216	1	VALVEPAC ASSEMBLY
4	0112272	1	HOSE ASSY, 1/4 WITH FITTINGS
5	0112418	2	FTG ELB90 -4S-4S
6	0112421	2	BLT SHCS .5-15UNC X 1.25 GR5
7	0112422	2	LOCK WASHER .50 SPTIL RING PLTD
8	0112423	4	BOLT .31-18UNC X 3.50 HHCS GR5
9	0112424	4	WASHER LOCK .31 PLATED

## Swing Drive Assembly – Perfection Gear



## Fuel Tank

Item	Part No.	Qty.	Description
1	0074680	2	Tank strap
2	0190685	1	Fuel tank, 54 gal
	0191831		Fuel tank with cap
3	0191690	1	Wldmt, fuel tank mount
4	970849	8	Bolt .500-13 X 1.25 Gr. 5
5	986299	4	Washer, flat .38
6	987139	8	Washer, lock .500
7	5560033	4	Nut, lock .375-16
8	9940021	1	Fuel cap, plastic

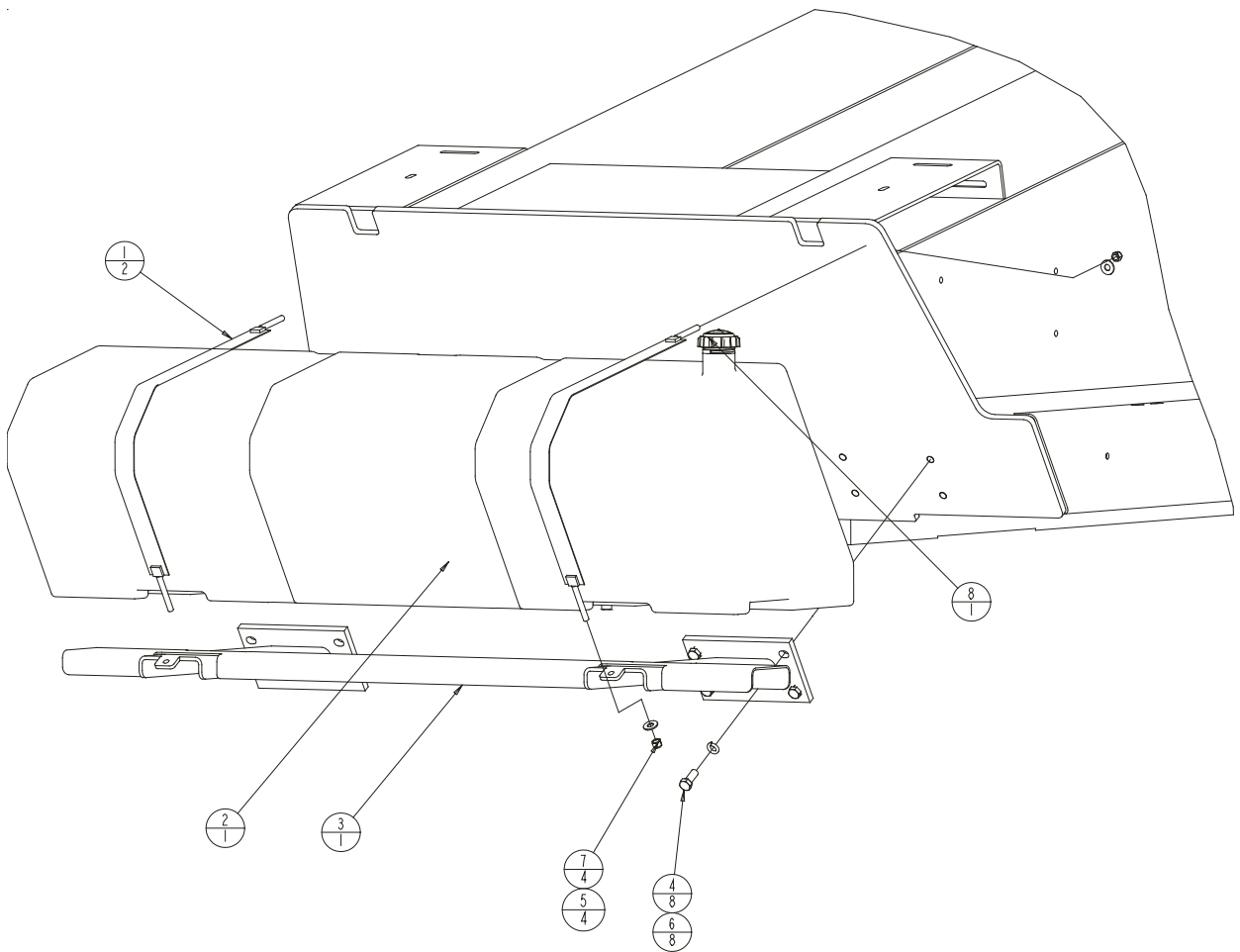

A19021A

## Fuel Tank



## Hydraulic Oil Reservoir Mounting

Item	Part No.	Qty.	Description
1	0110364	1	HYDRAULIC OIL RESERVOIR
2	5090007	1	LIQUID LEVEL GAUGE WITH THERMOMETER
3	0110362	2	MOUNT STRAP, HYDRAULIC OIL RESERVOIR
4	970029	4	CAPSCREW 1/4-20 X 3/4 HEXHD GR5
5	9870099	4	WASHER 1/4 MED LOCK
6	984069	4	NUT 1/4-20 HEX
7	7714304	1	PLUG, 1/2 NPT HOLLOW HEX
8	0110361	1	SUPPORT, HYDRAULIC OIL RESERVOIR
9	970449	4	CAPSCREW, 3/8-16 X 3/4 HEXHD GR5
10	987119	4	WASHER 3/8 MED LOCK
11	970469	7	CAPSCREW 3/8-16 X 1 HEXHD GR5
12	984109	4	NUT 3/8-16 HEX
13	5560033	5	NUT 3/8-16 SELF LOCKING
14	970629	2	CAPSCREW 3/8-16 X 5 HEXHD GR5
15	0110363	1	SPACER, HYDRAULIC OIL RESERVOIR

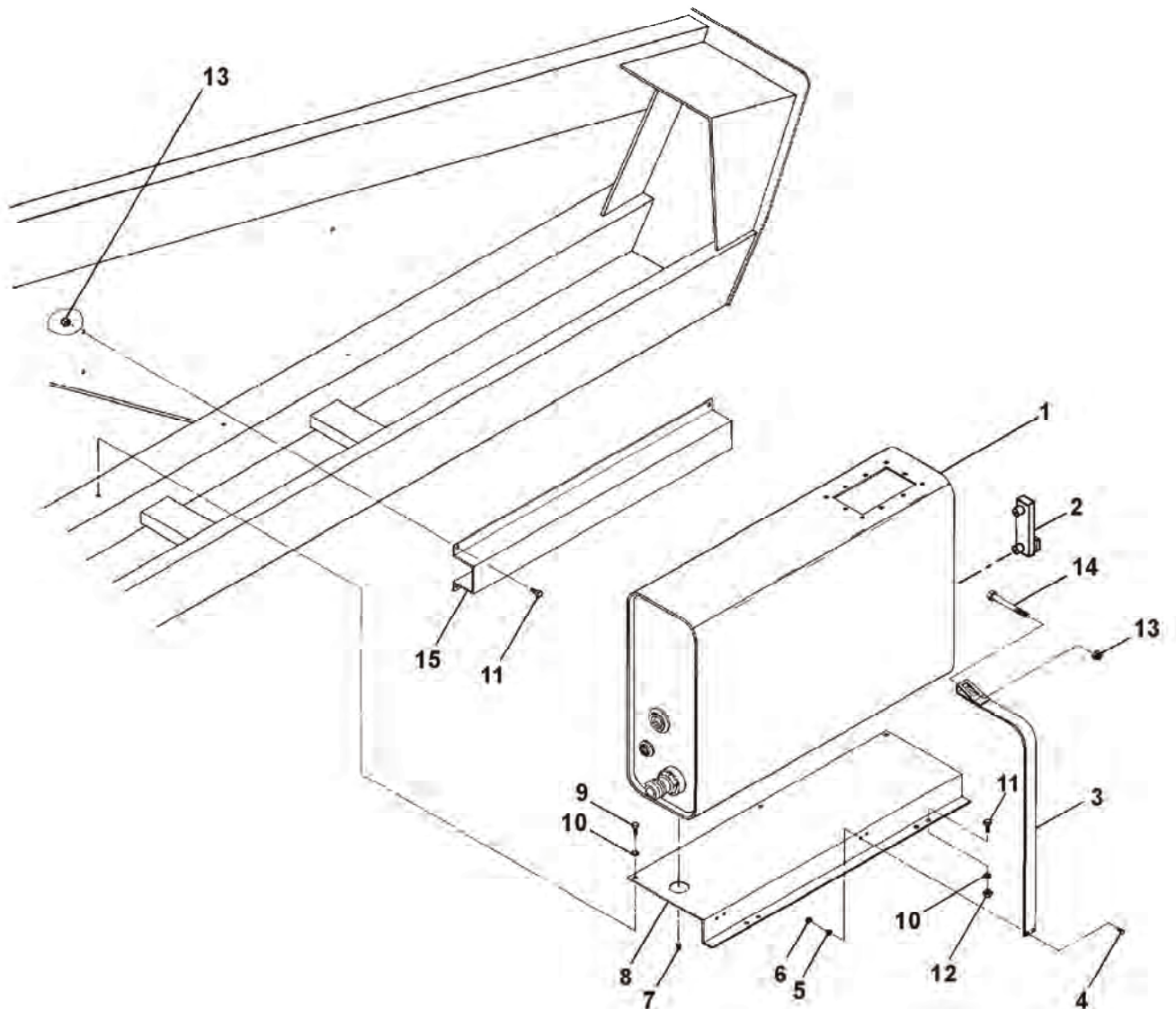

AWM00219

## Hydraulic Oil Reservoir Mounting



F

E

D

C

B

A

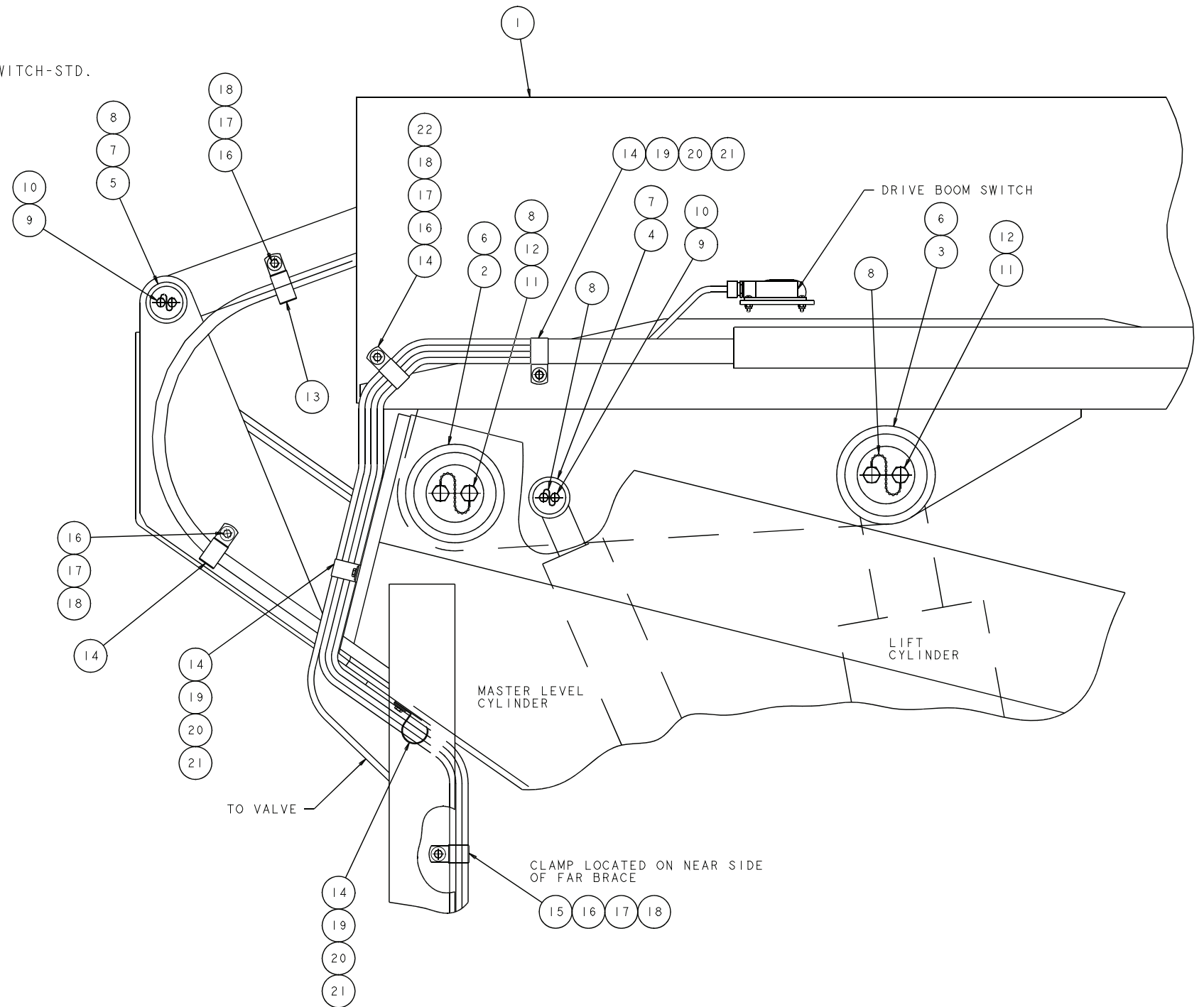
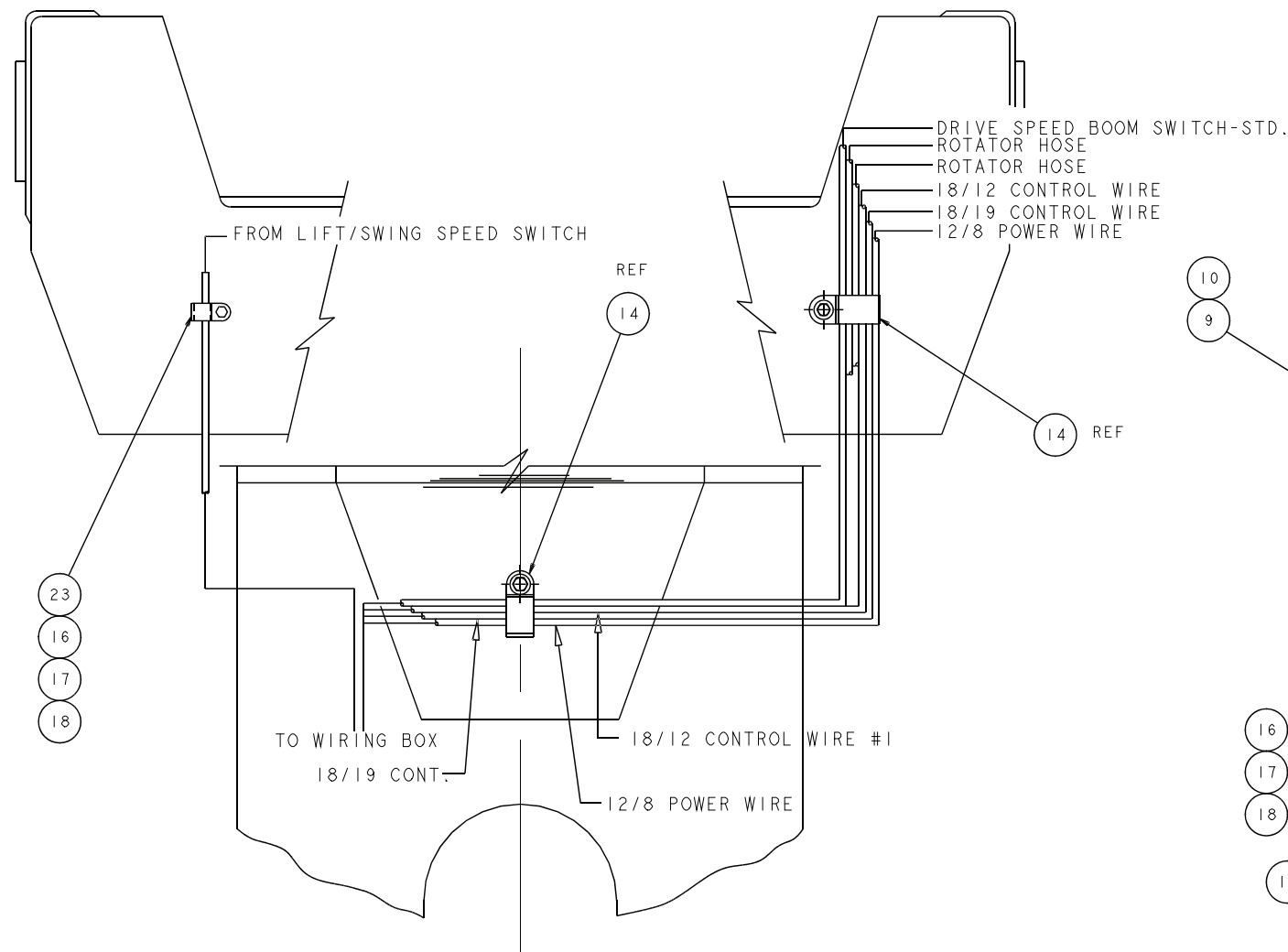

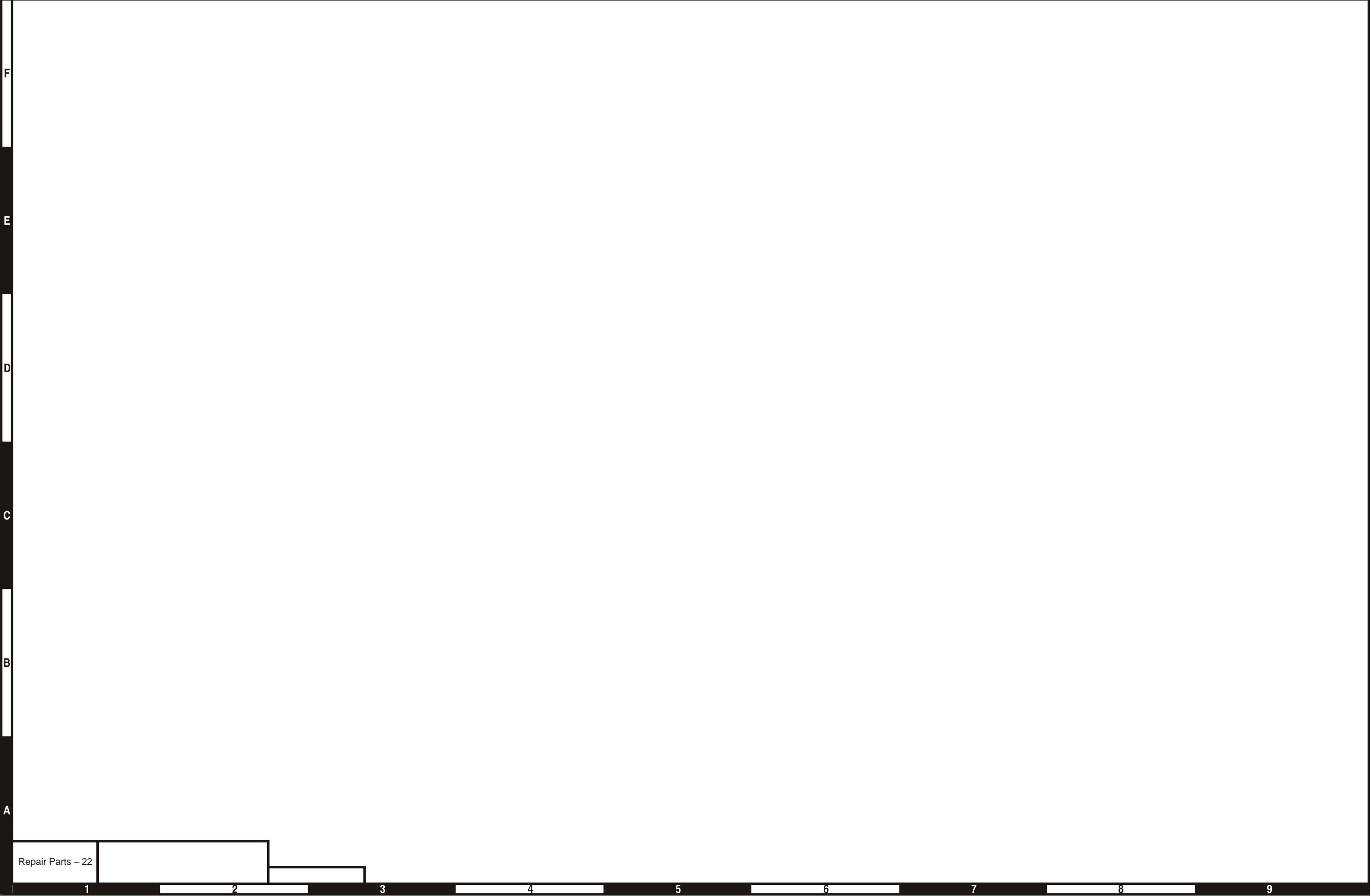

F

E

D

C

B

A

Repair Parts – 22

1

2

3

4

5

6

7

8

9

## Booms, Base End

Item	Part No.	Qty.	Description
1	0111897	1	BOOM/HOSE CARRIER ASSY – TB80
	0112529	1	BOOM/HOSE CARRIER ASSY – TB85J
2	0110238	1	PIN, BASE BOOM TO TURNTABLE
3	0110237	1	PIN, LIFT CYL TO BASE BOOM
4	0110236	1	PIN, LEVEL CYL TO BASE BOOM
5	0070440	1	PIN, LINK TO TURNTABL
6	0110235	2	PIN LOCK
7	0070033	2	PIN LOCK
8	9980012		.040 DIA. SS. SAFETY LOCKWIRE
9	0070473	4	DRILLED HEAD CAPSCREW, 5/16-18
10	987109	4	WASHER, 5/16 MEDIUM LOCK
11	0110681	4	DRILL HEAD CAPSCREW, 5/8-11
12	987159	4	WASHER, 5/8 MEDIUM LOCK
13	5093012	1	CLAMP (1.75)
14	5093010	5	CLAMP (1.50)
15	5093009	1	CLAMP (1.12)
16	970029	5	CAPSCREW, 1/4-20 X 3/4 LG HH
17	986019	5	WASHER, 1/4 FLAT
18	987099	5	WASHER, 1/4 MEDIUM LOCK
19	972449	3	CAPSCREW, 3/8-16 X 3/4 LG HH
20	986299	3	WASHER, 3/8 FLAT
21	987119	3	WASHER, 3/8 MEDIUM LOCK
22	5560004	1	NUT, 1/4-20 ESNA
23	5093002	1	CLAMP (.56)

## Booms, Base End





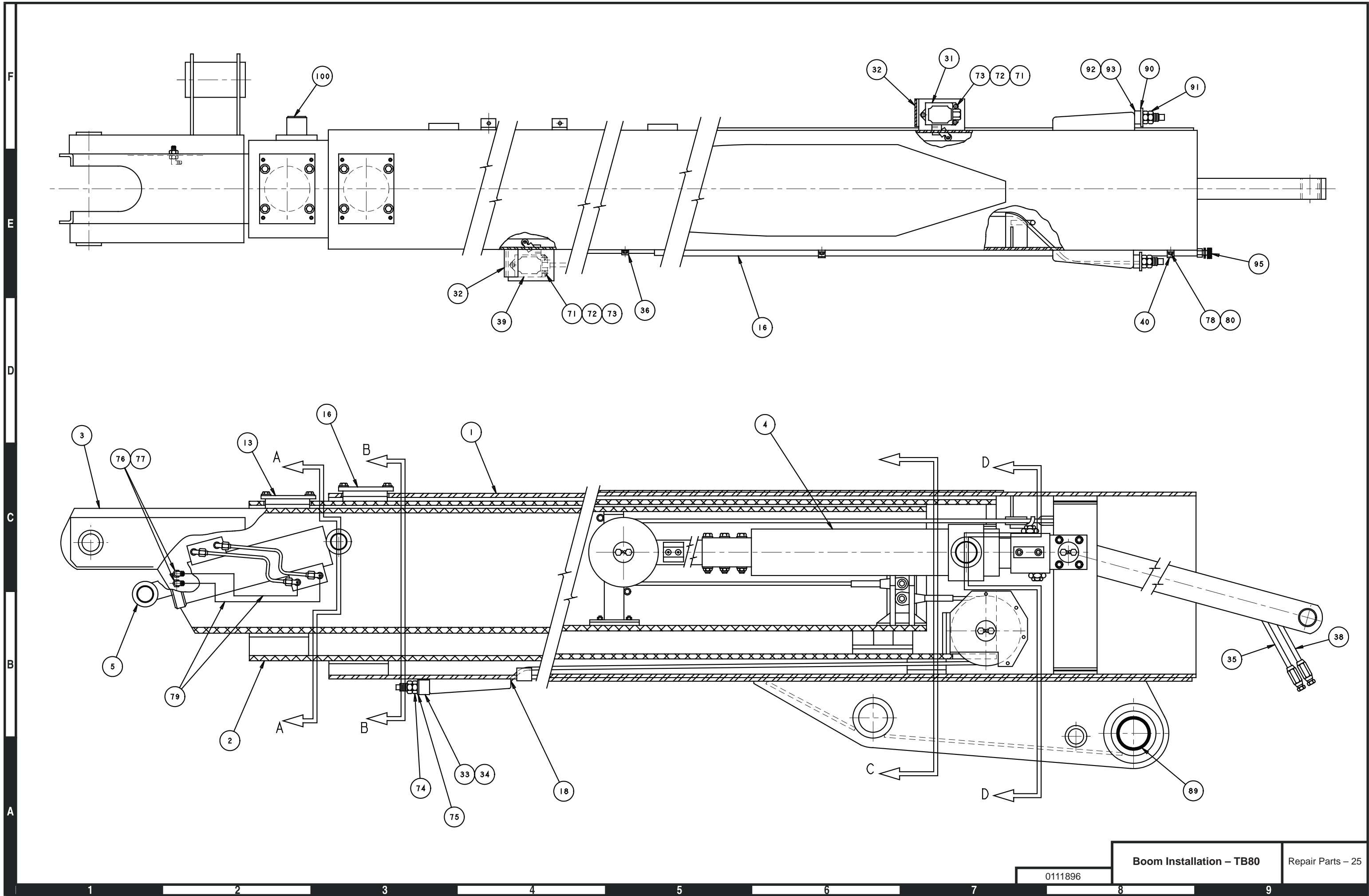

F

E

D

C

B

A

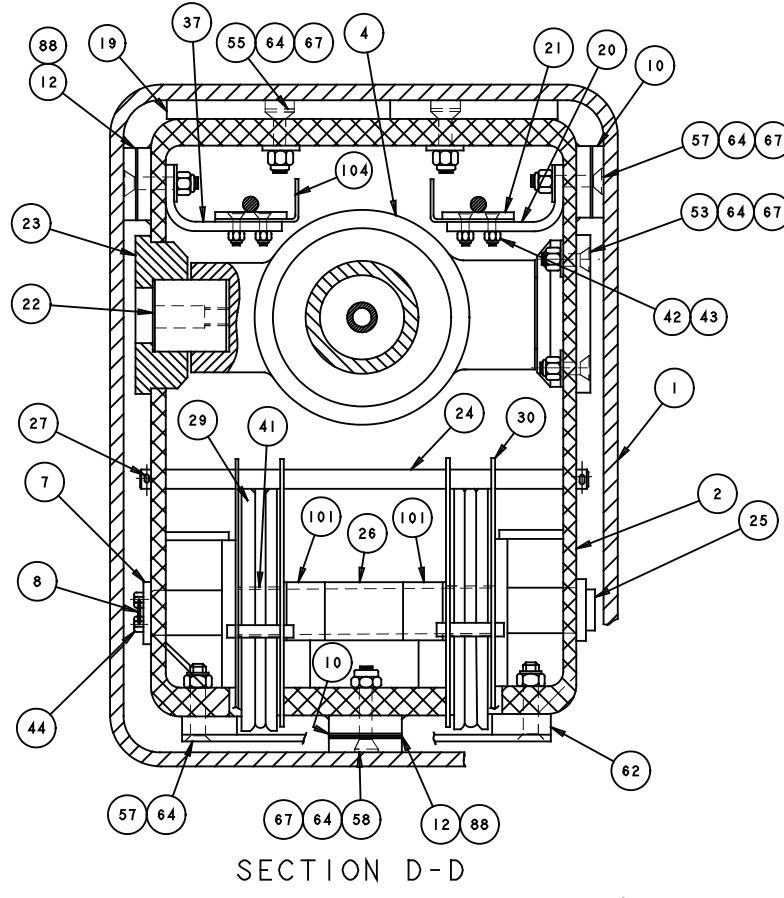
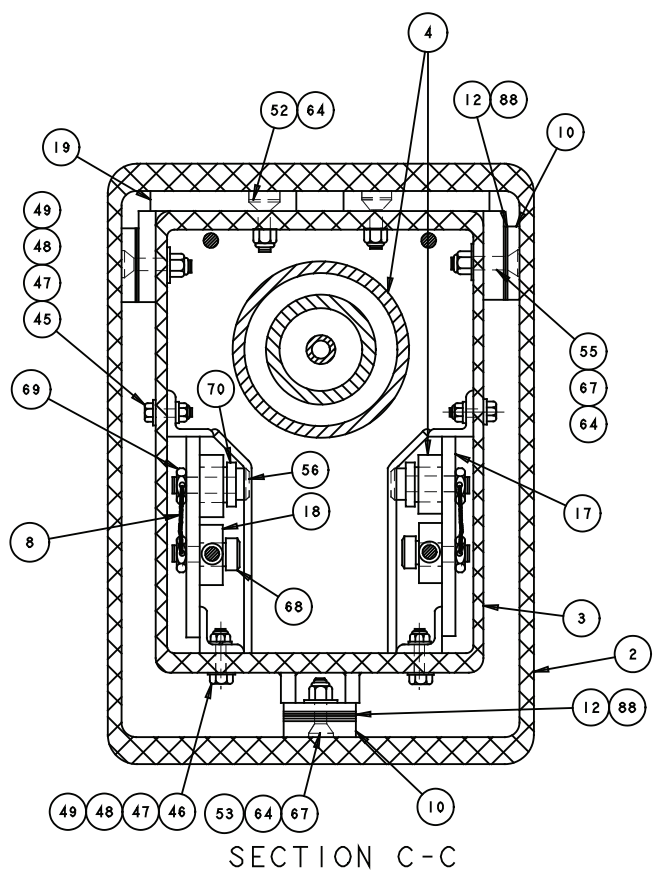
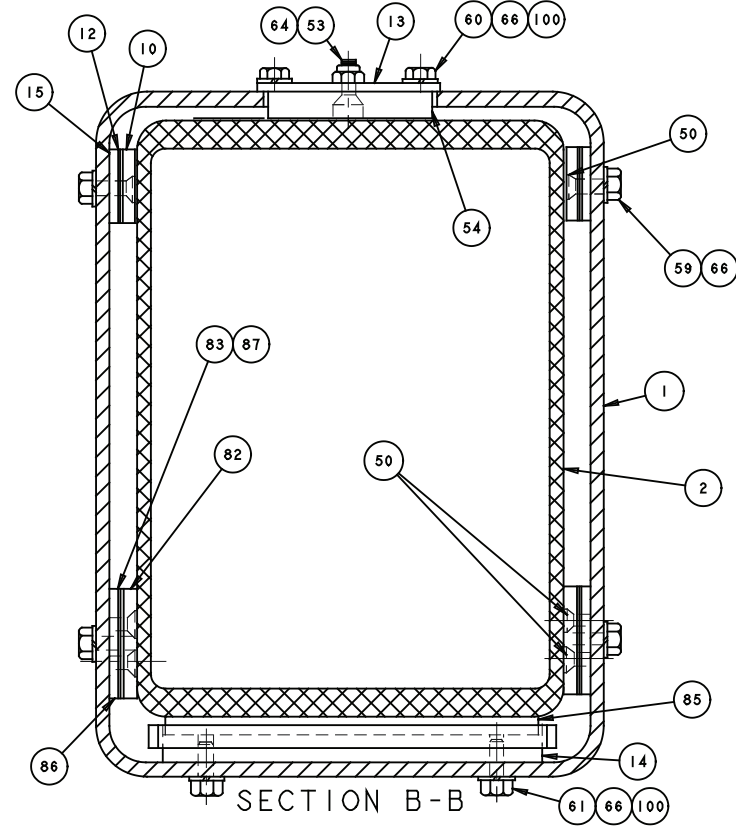
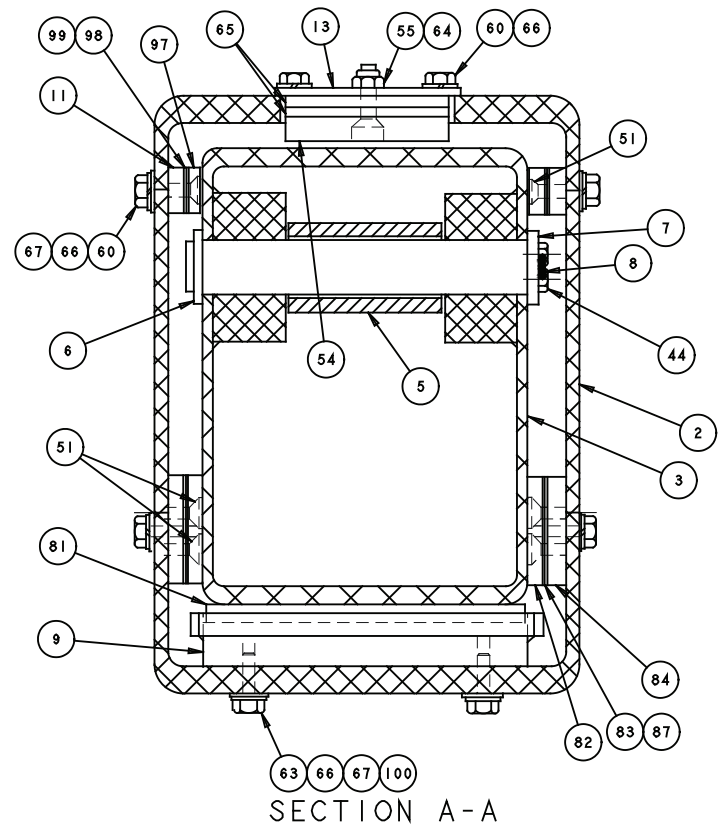

## Boom Installation – TB80

Item	Part No.	Qty.	Description
1	0110891	1	BASE BOOM WELDMENT
2	0110630	1	INTERMEDIATE BOOM WELDMENT
3	0110631	1	TIP BOOM WELDMENT
4	0110628	1	EXTEND CYLINDER ASSY
5	0071486	1	SLAVE LEVEL CYLINDER ASSY
6	0110661	1	PIN, LEVEL CYLINDER TO TIP BOOM
7	0070033	2	PIN LOCK
8	9980012		.040 DIA. S.S. SAFETY LOCKWIRE
9	0110699	1	PAD PLATE WLDMT (INTER. BOOM OUTER)
10	0080293	8	SLIDE PAD
11	0090444	2	SPACER (1/2)
12	0070030	22	SHIM
13	0072681	2	SLIDE PAD MOUNT
14	0110700	1	PAD PLATE WLDMT (BASE BOOM OUTER)
15	0070486	2	SPACER
16	0110547	1	CONDUIT
17	0110665	2	WIRE ROPE ANCHOR WELDMENT
18	0110186	2	WIRE ROPE ASSY - RETRACT
19	0110703	4	SLIDE PAD
20	0110705	1	CABLE SUPPORT-LH
21	0060089	2	SLIDE PAD
22	0110190	2	PIN, CYLINDER ANCHOR
23	0110191	2	CYLINDER ANCHOR
24	0110670	1	PIN, CABLE RETAINER
25	0110671	1	PIN, RETRACT SHEAVE
26	2502032	1	BEARING
27	988179	2	COTTER PIN, 1/8 DIA X 1 LG
28	0071342	1	SHIM
29	0111700	2	CABLE SHEAVE
30	0111322	2	SHEAVE CAGE
31	011188828	1	BOOM SWITCH ASSY, DRIVE SPEED
32	0071216	2	GUARD
33	0071921	2	SPACER
34	0071922	2	SPACER
35	0151860	2	1/2 I.D. HOSE ASSY
36	5093000	1	CLAMP (A. 44)
37	0110704	1	CABLE SUPPORT - R.H.
38	0080522	1	1/2 I.D. HOSE ASSY
39	011188928	1	BOOM SWITCH ASSY, LIFT/SWING SPEED
40	5093004	3	CLAMP (A. 75)
41	2502028	2	BEARING, 1-1/4 BORE X 1 LG GARMAX
42	5560331	4	M SCR 1/4-20 1.0 H.F SOC. CAD PL
43	5560004	4	NUT, 1/4-20 ESNA
44	0070473	2	BLT, 5/16-18 X 3/4 LG HH DR
45	970259	6	CAPSCREW, 5/16-18 X 1 LG HH
46	970269	6	CAPSCREW, 5/26-18X 1-1/4 LG HH
47	5560031	12	NUT, 5/16-18 ESNA
48	987109	12	WASHER, 5/16 MEDIUM LOCK
49	986269	12	WASHER, 5/16 FLAT
50	5560679	16	M SCR, 3/8-16 5/8 F.H. SOC. CAD
51	972449	22	M SCR, 3/8-16 3/4 F.H. SOC. CAD
52	978409	6	M SCR, 3/8-16 1-1/2 F.H. SOC. CAD
53	5560644	16	M SCR, 3/8-16 1-1/4 F.H. SOC. CAD
54	0072682	2	SLIDE PAD
55	5560680	11	M SCR, 3/8-16 1-3/4 F.H. SOC. CAD
56	5560146	2	ANCHOR BOLT
57	5560681	8	M SCR, 3/8-16 2-1/4 F.H. SOC. CAD
58	5560682	3	M SCR, 3/8-16 2-1/2 F.H. SOC. CAD
59	5560683	10	CAPSCREW, 3/8-16 X 5/8 LG HH

## Boom Installation – TB80

## Boom Installation – TB80

Item	Part No.	Qty.	Description
60	970449	18	CAPSCREW, 3/8-16 X 3/4 LG HH
61	970469	8	CAPSCREW, 3/8-16 X 1 LG HH
62	0111317	1	CABLE RETAINER
63	972489	6	CAPSCREW, 3/8-16 X 1-1/2 LG HH
64	5560033	50	NUT, 3/8-16 ESNA
65	0072683	2	SPACER
66	987119	36	WASHER, 3/8 MEDIUM LOCK
67	986299	48	WASHER, 3/8 FLAT
68	5560005	2	ANCHOR BOLT
69	5560053	4	HEX JAM NUT, DRILLED
70	0111005	2	SPACER
71	5560649	6	M SCR, #10-24 X 1 LG, TRUSS HEAD
72	986009	6	WASHER, #10 FLAT
73	984049	6	NUT, #10-24 HEX
74	984469	4	NUT, 3/4-10 HEX JAM
75	5560170	4	WASHER, 3/4 HARD FLAT
76	5074401	2	BULKHEAD LOCKNUT
77	5034501	2	BULKHEAD 90ELBOW
78	987099	4	WASHER, 1/4 MEDIUM LOCK
79	0070768	2	1/4 I.D. HOSE ASSY
80	970009	4	CAPSCREW, 1/4-20 X 1/2 LG HH PLATED
81	0110695	1	SLIDE PAD
82	0070639	2	SLIDE PAD
83	0110706	6	SHIM (.030)
84	0110701	2	SPACER
85	0110696	1	SLIDE PAD
86	0110702	2	SPACER
87	0110707	6	SHIM (.090)
88	0090141	10	SHIM (.090)
89	2504857		BEARING
90	5560684	4	WASHER, 7/8 HARD FLAT ASTM F-436
91	5560685	4	NUT, 7/8-9 HEX JAM
92	0110976	2	SPACER
93	0110977	2	SPACER
94	3070262	2	CONDUIT COUPLER, 1/2
95	3040189	2	CONNECTOR
96	0073111		SLIDE PAD SPACER
97	0080294	2	SLIDE PAD
98	0070043	2	SHIM (.030)
99	0073343	2	SHIM (.090)
100	5560015	20	3/8 THREADED INSERT
101	2500035	2	SPACER
104	0111324	2	CABLE GUIDE

## Boom Installation – TB80

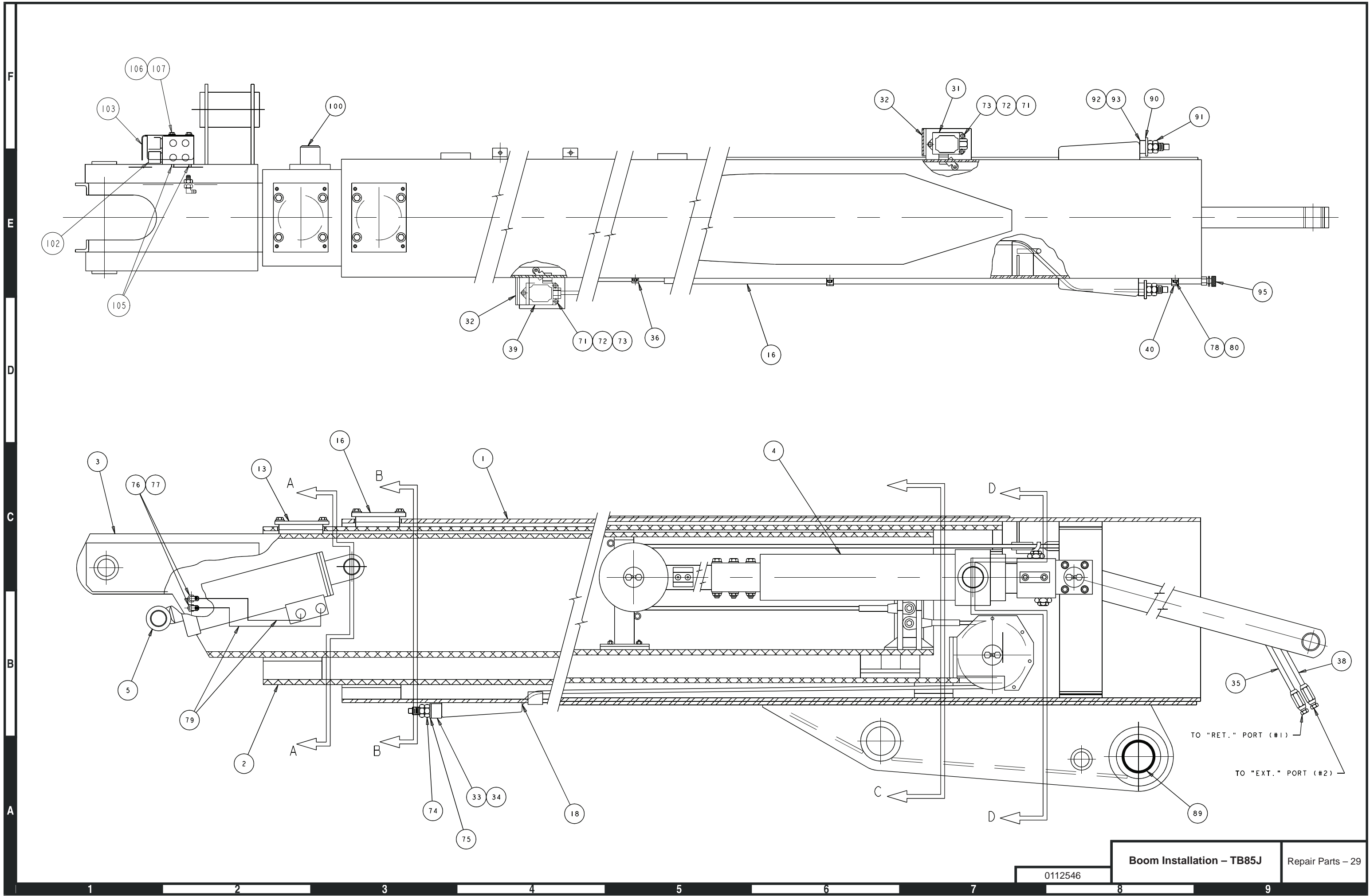

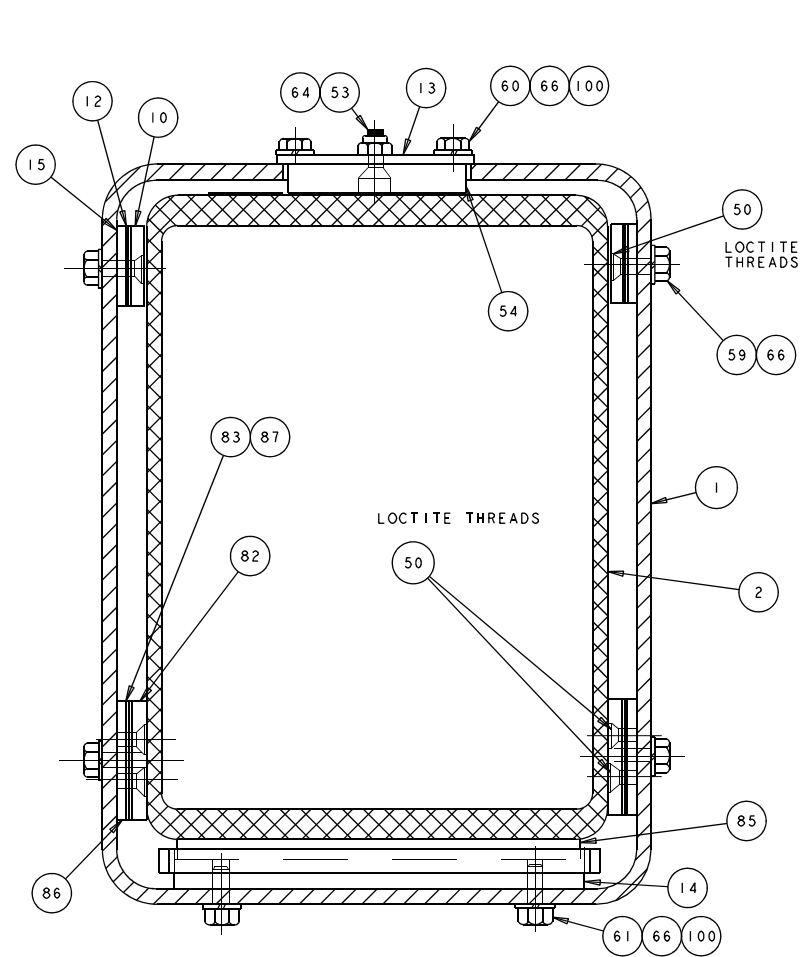

SECTION B-B

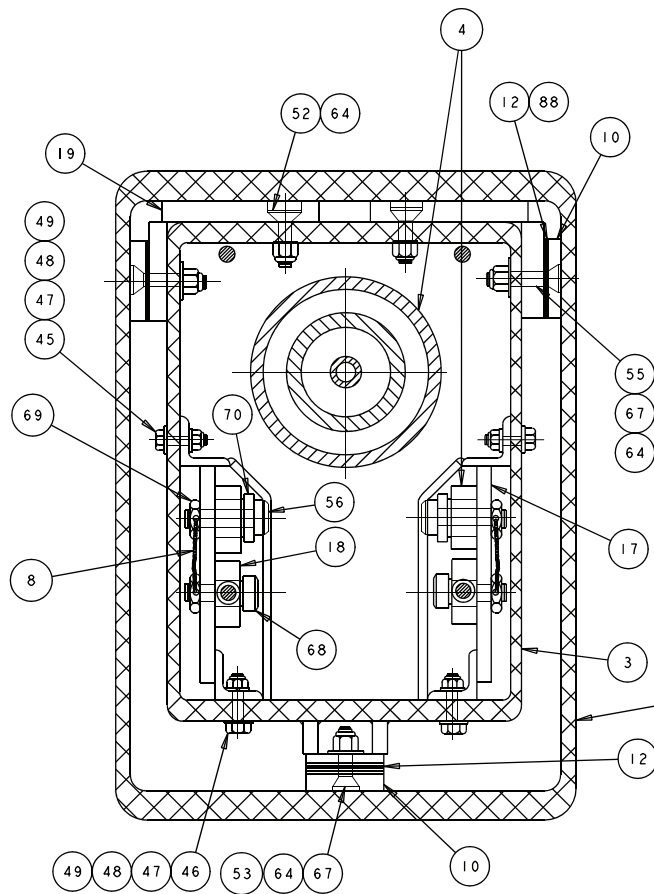

SECTION C-C

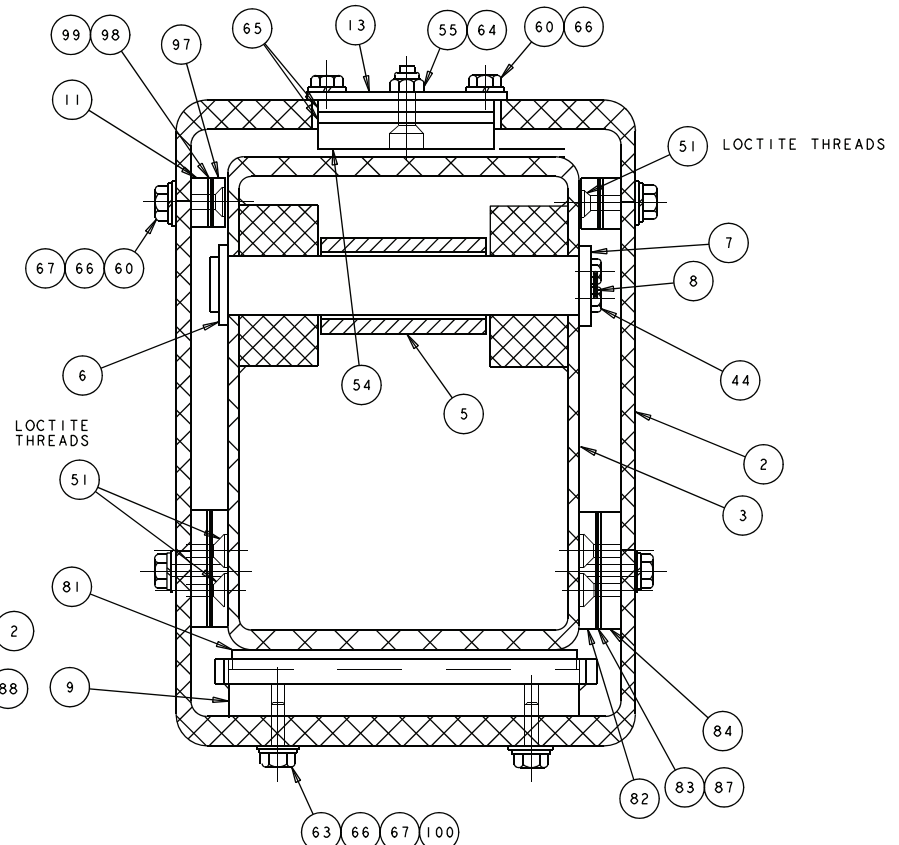

SECTION A-A

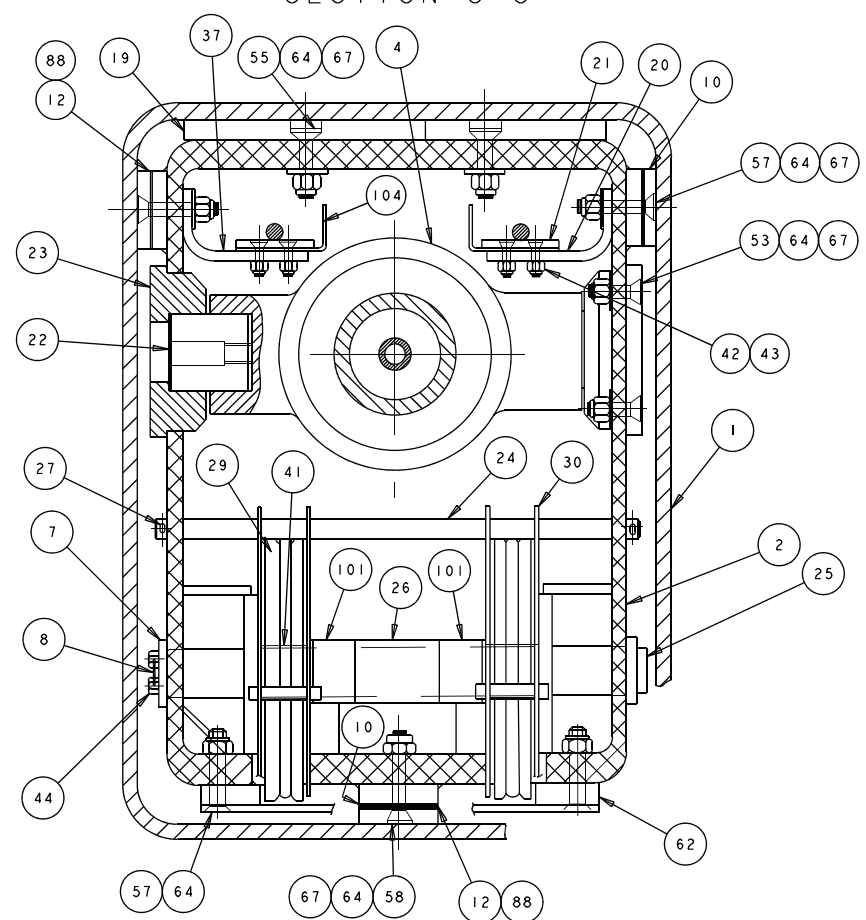

SECTION D-D

## Boom Installation – TB85J

Item	Part No.	Qty.	Description
1	0110891	1	BASE BOOM WELDMENT
2	0110630	1	INTERMEDIATE BOOM WELDMENT
3	0110631	1	TIP BOOM WELDMENT
4	0110628	1	EXTEND CYLINDER ASSY
5	0172224	1	SLAVE LEVEL CYLINDER ASSY
6	0110661	1	PIN, LEVEL CYLINDER TO TIP BOOM
7	0070033	2	PIN LOCK
8			.040 DIA. S.S. SAFETY LOCKWIRE
9	0110699	1	PAD PLATE WLDMT (INTER. BOOM OUTER)
10	0080293	8	SLIDE PAD
11	0090444	2	SPACEER (1/2)
12	0070030	22	SHIM
13	0072681	2	SLIDE PAD MOUNT
14	0110700	1	PAD PLATE WLDMT (BASE BOOM OUTER)
15	0070486	2	SPACER
16	0110547	1	CONDUIT
17	0110665	2	WIRE ROPE ANCHOR WELDMENT
18	0110186	2	WIRE ROPE ASSY - RETRACT
19	0110703	4	SLIDE PAD
20	0110705	1	CABLE SUPPORT-LH
21	0060089	2	SLIDE PAD
22	0110190	2	PIN, CYLINDER ANCHOR
23	0110191	2	CYLINDER ANCHOR
24	0110670	1	PIN, CABLE RETAINER
25	0110671	1	PIN, RETRACT SHEAVE
26	2502032	1	BEARING
27	988179	2	COTTER PIN, 1/8 DIA X 1 LG
28	0071342	1	SHIM
29	0111700	2	CABLE SHEAVE
30	0111322	2	SHEAVE CAGE
31	011188828	1	BOOM SWITCH ASSY, DRIVE SPEED
32	0071216	2	GUARD
33	0071921	2	SPACER
34	0071922	2	SPACER
35	0151860	2	1/2 I.D. HOSE ASSY
36	5093000	1	CLAMP (A. 44)
37	0110704	1	CABLE SUPPORT - R.H.
38	0080522	1	1/2 I.D. HOSE ASSY
39	011188928	1	BOOM SWITCH ASSY, LIFT/SWING SPEED
40	5093004	3	CLAMP (A. 75)
41	2502028	2	BEARING, 1-1/4 BORE X 1 LG GARMAX
42	5560680	4	M SCR 1/4-20 1.0 H.F SOC. CAD PL
43	5560004	4	NUT, 1/4-20 ESNA
44	0070473	2	BLT, 5/16-18 X 3/4 LG HH DR
45	970259	6	CAPSCREW, 5/16-18 X 1 LG HH
46	970269	6	CAPSCREW, 5/26-18X 1-1/4 LG HH
47	5560031	12	NUT, 5/16-18 ESNA
48	987109	12	WASHER, 5/16 MEDIUM LOCK
49	986269	12	WASHER, 5/16 FLAT
50	5560679	16	M SCR, 3/8-16 5/8 F.H. SOC. CAD
51	972449	22	M SCR, 3/8-16 3/4 F.H. SOC. CAD
52	978409	6	M SCR, 3/8-16 1-1/2 F.H. SOC. CAD
53	5560644	16	M SCR, 3/8-16 1-1/4 F.H. SOC. CAD
54	0072682	2	SLIDE PAD
55	5560680	11	M SCR, 3/8-16 1-3/4 F.H. SOC. CAD
56	5560146	2	ANCHOR BOLT
57	5560681	8	M SCR, 3/8-16 2-1/4 F.H. SOC. CAD
58	5560682	3	M SCR, 3/8-16 2-1/2 F.H. SOC. CAD
59	5560683	10	CAPSCREW, 3/8-16 X 5/8 LG HH

## Boom Installation – TB85J

## Boom Installation – TB85J

Item	Part No.	Qty.	Description
60	970449	18	CAPSCREW, 3/8-16 X 3/4 LG HH
61	970469	8	CAPSCREW, 3/8-16 X 1 LG HH
62	0111317	1	CABLE RETAINER
63	972489	6	CAPSCREW, 3/8-16 X 1-1/2 LG HH
64	5560033	50	NUT, 3/8-16 ESNA
65	0072683	2	SPACER
66	987119	36	WASHER, 3/8 MEDIUM LOCK
67	986299	48	WASHER, 3/8 FLAT
68	5560005	2	ANCHOR BOLT
69	5560053	4	HEX JAM NUT, DRILLED
70	0111005	2	SPACER
71	5560649	6	M SCR, #10-24 X 1 LG, TRUSS HEAD
72	986009	6	WASHER, #10 FLAT
73	984049	6	NUT, #10-24 HEX
74	984469	4	NUT, 3/4-10 HEX JAM
75	5560170	4	WASHER, 3/4 HARD FLAT
76	5074401	2	BULKHEAD LOCKNUT
77	5034501	2	BLUKHEAD 90ELBOW
78	987099	4	WASHER, 1/4 MEDIUM LOCK
79	0070768	2	1/4 I.D. HOSE ASSY
80	970009	4	CAPSCREW, 1/4-20 X 1/2 LG HH PLATED
81	0110695	1	SLIDE PAD
82	0070639	2	SLIDE PAD
83	0110706	6	SHIM (.030)
84	0110701	2	SPACER
85	0110696	1	SLIDE PAD
86	0110702	2	SPACER
87	0110707	6	SHIM (.090)
88	0090141	10	SHIM (.090)
89	2504857		BEARING GARMAX
90	5560684	4	WASHER, 7/8 HARD FLAT ASTM F-436
91	5560685	4	NUT, 7/8-9 HEX JAM
92	0110976	2	SPACER
93	0110977	2	SPACER
94	3070262	2	CONDUIT COUPLER, 1/2
95	3040189	2	CONNECTOR
96	0073111		SLIDE PAD SPACER
97	0080294	2	SLIDE PAD
98	0070043	2	SHIM (.030)
99	0073343	2	SHIM (.090)
100	5560015	20	3/8 THREADED INSERT
101	2500035	2	SPACER
102	0112796	1	PLAT/JIB SELECTOR VALVE ASSY
103	0112795	1	COVER
104	0111324	2	CABLE GUIDE
105	5560603	2	NUT-SERT .250-20
106	970159	2	BLT HEXHD .250-20 X 3.50 LG
107	986019	2	WASHER FLAT .25

## Boom Installation – TB85J



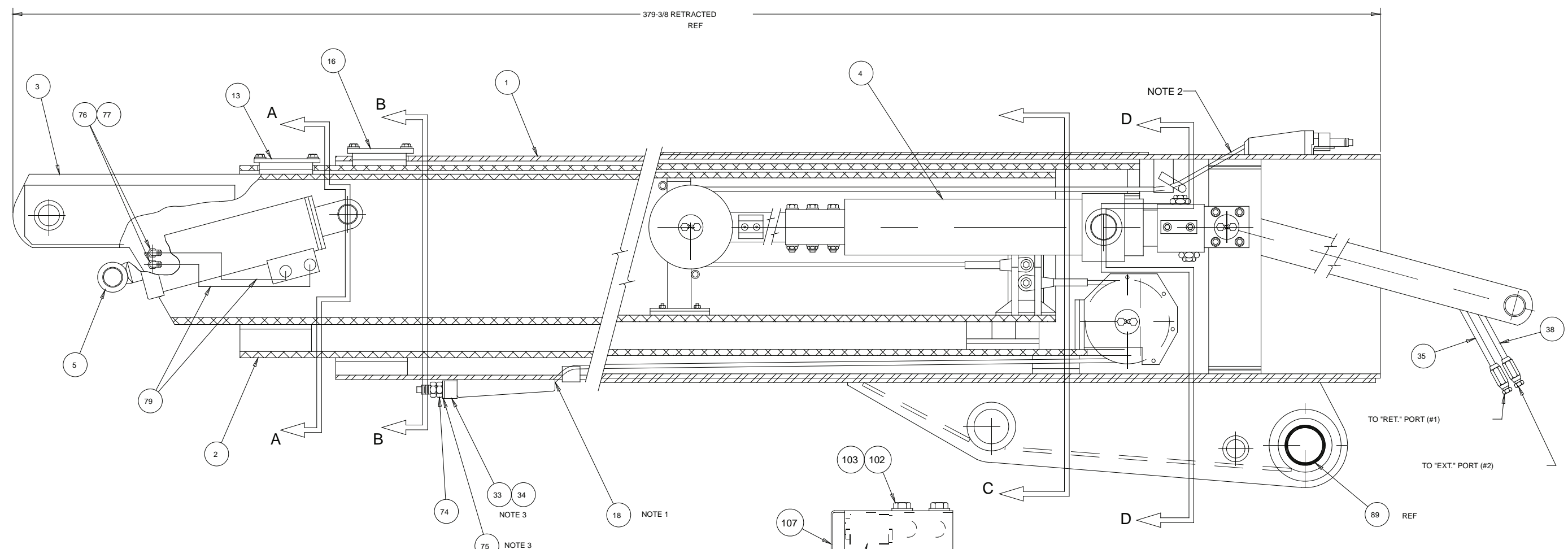
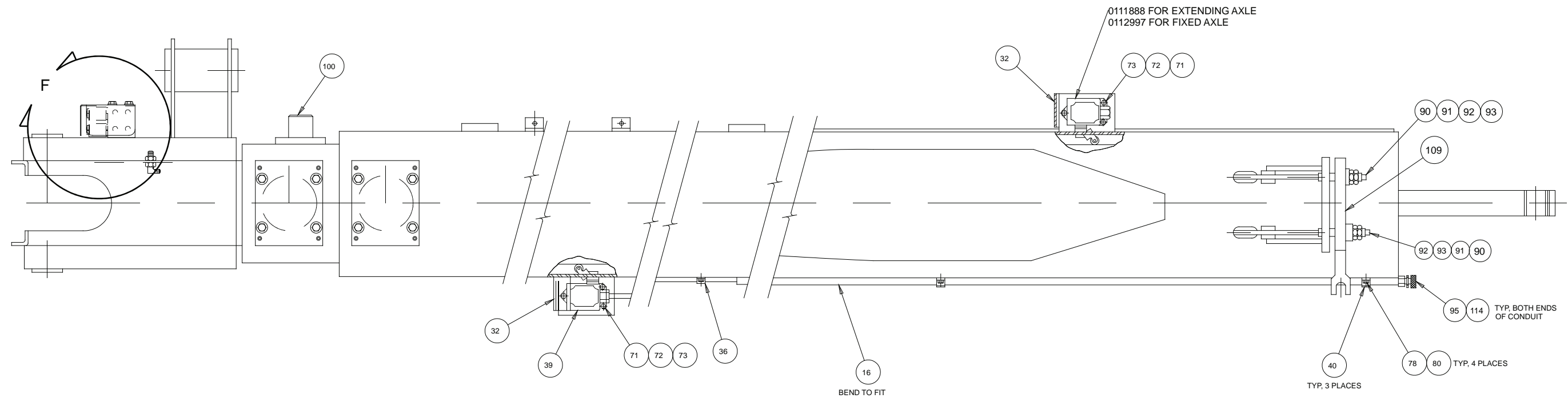

- NOTES:
1. WIRE ROPE ASSEMBLY (ITEM 18) TO REMAIN OUTSIDE BASE BOOM UNTIL SHEAVES ON INTERMEDIATE BOOM PASS BEYOND SLOT. PULL (ITEM 18) THRU SLOT AND HOLD SNUG WHILE ASSEMBLING BOOMS. DISASSEMBLE IN OPPOSITE MANNER.
  2. INSTALL TOP WIRE ROPE IN GUIDE WHILE AREA IS CLEAR, ALLOW SLACK OF WIRE ROPE TO FORM "S" CURVE TO SLIDE BY THE KEEPER.
  3. WHEN LARGE QUANTITY OF WASHERS (ITEMS 75 OR 90) IS REQUIRED, USE SPACERS (ITEMS 33, 34 OR 92, 93) AS REQUIRED TO KEEP QUANTITY OF WASHERS AT A MINIMUM.
  4. 0070485 SPACER MAY BE USED IN PLACE OF 0070486 SPACER (ITEM 15) IF THICKER SPACER IS REQUIRED.
  5. ACTUAL QUANTITY OF SHIMS REQUIRED (ITEMS 12 AND 88) TO BE DETERMINED AT ASSEMBLY TO PROVIDE CLOSE SLIDING FIT BETWEEN BOOMS.

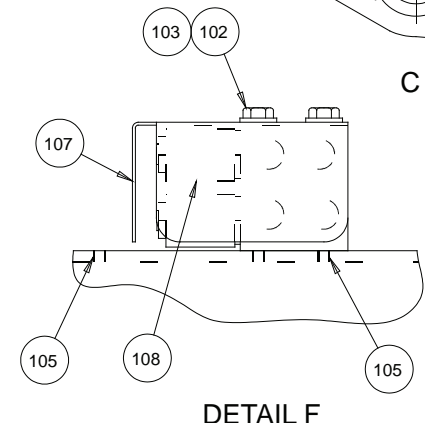

F  
E  
D  
C  
B  
A

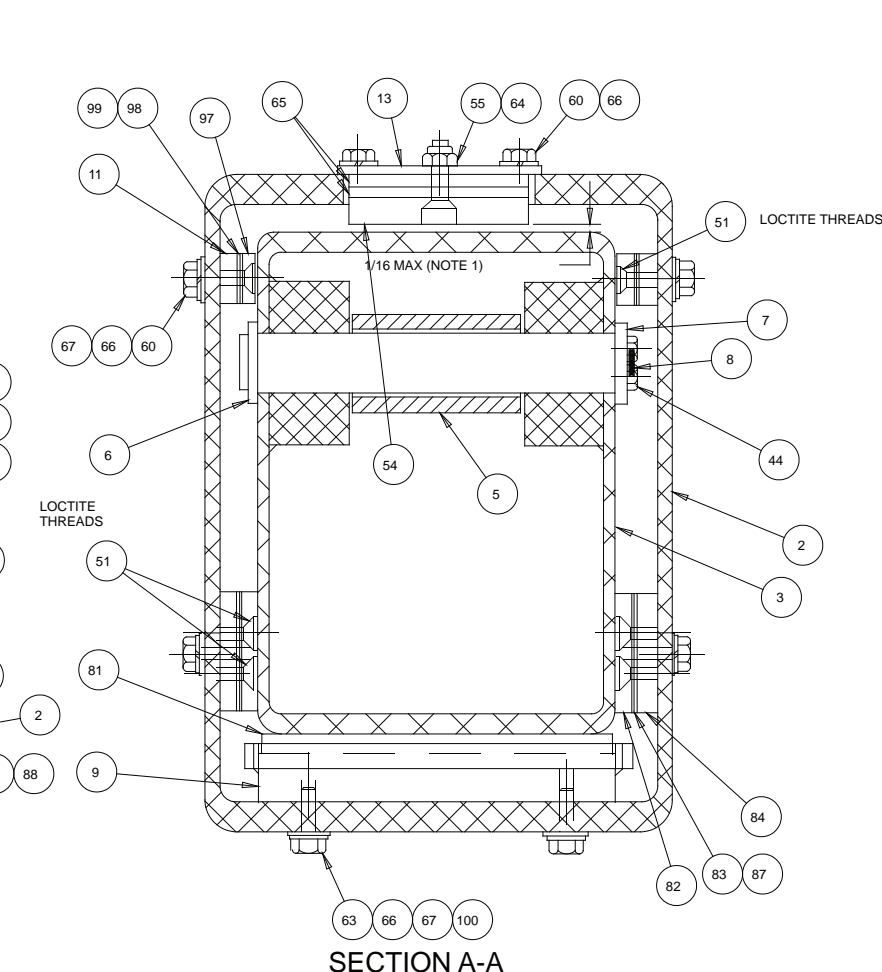
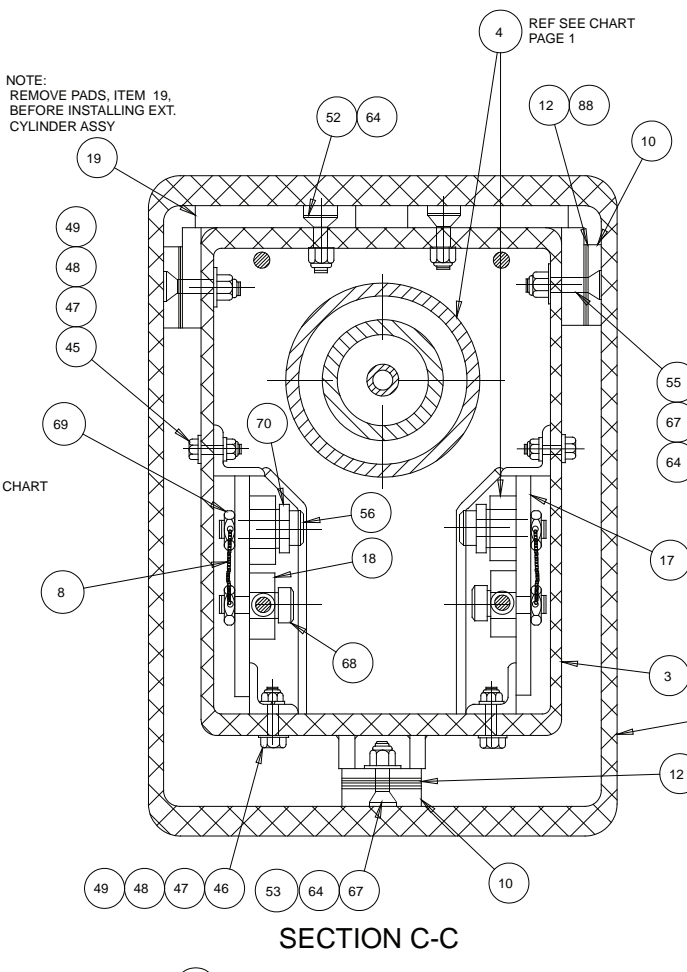
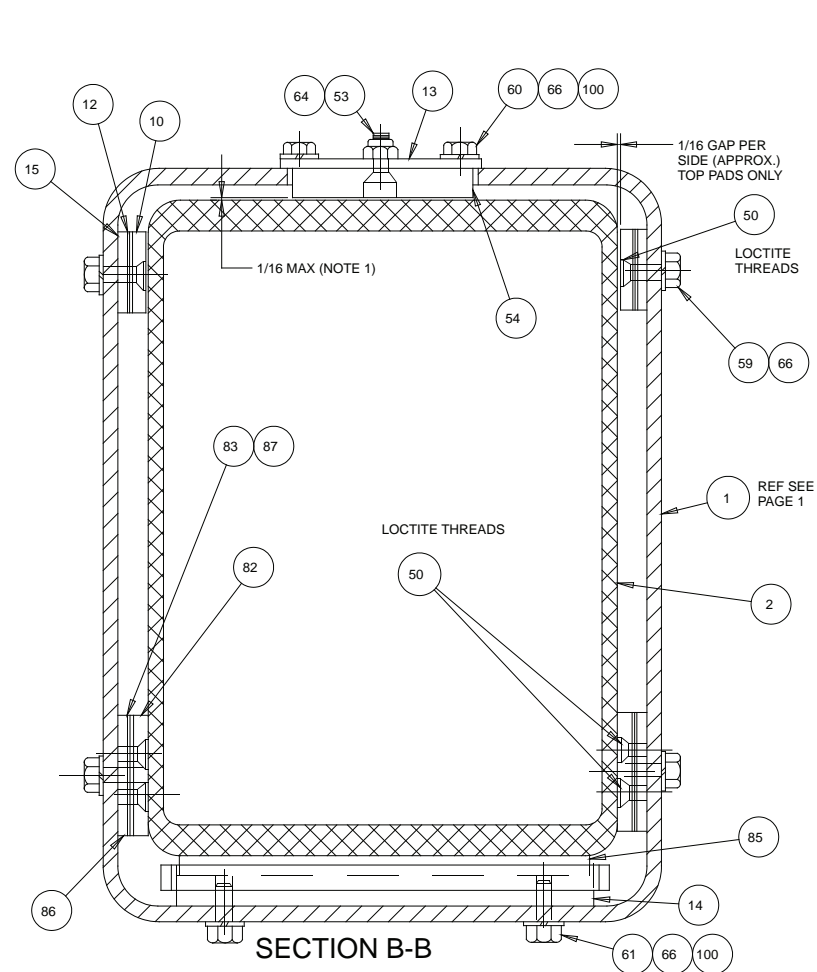

NOTES:  
 1. USE SPACERS 0072683 (1/4") OR 0073111 (1/8") TO PROVIDE 1/16" MAX GAP ABOVE TIP AND INTER. BOOMS AS NOTED. (FLATWASHERS UNDER MOUNT PLATES, ITEMS 13, MAY BE USED WHEN NEEDED).  
 2. SHIM (ITEM 28, 0071342) TO MINIMIZE GAP BETWEEN EXTEND CYL. SIDE WEAR PADS AND INSIDE TIP BOOM. MAX. RECOMMENDED GAP 1/8 INCH.

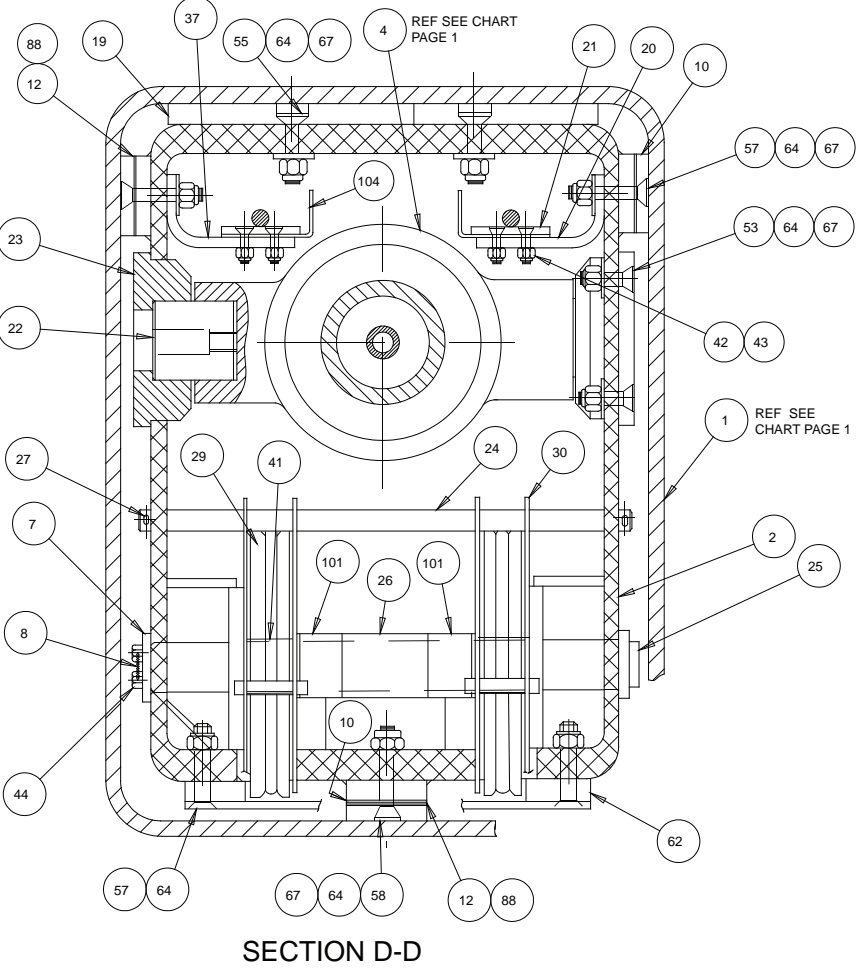

F  
E  
D  
C  
B  
A

## Boom Installation – CE

Item	Part No.	Qty.	Description
1	0111099	1	BASE BOOM WELDMENT
2	0110630	1	INTERMEDIATE BOOM WELDMENT
3	0110631	1	TIP BOOM WELDMENT
4	0110628	1	EXTEND CYLINDER ASSY
5	0172230	1	SLAVE LEVEL CYLINDER ASSY
6	0110661	1	PIN, LEVEL CYLINDER TO TIP BOOM
7	0070033	2	PIN LOCK
8	9980012		.040 DIA. S.S. SAFETY LOCKWIRE
9	0110699	1	PAD PLATE WLDMT (INTER. BOOM OUTER)
10	0080293	8	SLIDE PAD
11	0090444	2	SPACEER (1/2)
12	0070030	22	SHIM
13	0072681	2	SLIDE PAD MOUNT
14	0110700	1	PAD PLATE WLDMT (BASE BOOM OUTER)
15	0070486	2	SPACER
16	0110547	1	CONDUIT
17	0110665	2	WIRE ROPE ANCHOR WELDMENT
18	0110186	2	WIRE ROPE ASSY - RETRACT
19	0110703	4	SLIDE PAD
20	0110705	1	CABLE SUPPORT-LH
21	0060089	2	SLIDE PAD
22	0110190	2	PIN, CYLINDER ANCHOR
23	0110191	2	CYLINDER ANCHOR
24	0110670	1	PIN, CABLE RETAINER
25	0110671	1	PIN, RETRACT SHEAVE
26	2502032	1	BEARING
27	988179	2	COTTER PIN, 1/8 DIA X 1 LG
28	0071342	1	SHIM
29	0111700	2	CABLE SHEAVE
30	0111322	2	SHEAVE CAGE
32	0071216	2	GUARD
33	0071921	2	SPACER
34	0071922	2	SPACER
35	0151860	2	1/2 I.D. HOSE ASSY
36	5093000	1	CLAMP (A. 44)
37	0110704	1	CABLE SUPPORT - R.H.
38	0080522	1	1/2 I.D. HOSE ASSY
39	011188928	1	BOOM SWITCH ASSY, LIFT/SWING SPEED
40	5093004	3	CLAMP (A. 75)
41	2502028	2	BEARING, 1-1/4 BORE X 1 LG GARMAX
42	5560680	4	M SCR 1/4-20 1.0 H.F SOC. CAD PL
43	5560004	4	NUT, 1/4-20 ESNA
44	0070473	2	BLT, 5/16-18 X 3/4 LG HH DR
45	970259	6	CAPSCREW, 5/16-18 X 1 LG HH
46	970269	6	CAPSCREW, 5/26-18X 1-1/4 LG HH
47	5560031	12	NUT, 5/16-18 ESNA
48	987109	12	WASHER, 5/16 MEDIUM LOCK
49	986269	12	WASHER, 5/16 FLAT
50	5560679	16	M SCR, 3/8-16 5/8 F.H. SOC. CAD
51	972449	22	M SCR, 3/8-16 3/4 F.H. SOC. CAD
52	978409	6	M SCR, 3/8-16 1-1/2 F.H. SOC. CAD
53	5560644	16	M SCR, 3/8-16 1-1/4 F.H. SOC. CAD
54	0072682	2	SLIDE PAD
55	5560680	11	M SCR, 3/8-16 1-3/4 F.H. SOC. CAD
56	5560146	2	ANCHOR BOLT
57	5560681	8	M SCR, 3/8-16 2-1/4 F.H. SOC. CAD
58	5560682	3	M SCR, 3/8-16 2-1/2 F.H. SOC. CAD
59	5560683	10	CAPSCREW, 3/8-16 X 5/8 LG HH
60	970449	18	CAPSCREW, 3/8-16 X 3/4 LG HH

## Boom Installation – CE

## Boom Installation – CE

Item	Part No.	Qty.	Description
61	970469	8	CAPSCREW, 3/8-16 X 1 LG HH
62	0111317	1	CABLE RETAINER
63	972489	6	CAPSCREW, 3/8-16 X 1-1/2 LG HH
64	5560033	50	NUT, 3/8-16 ESNA
65	0072683	2	SPACER
66	987119	36	WASHER, 3/8 MEDIUM LOCK
67	986299	48	WASHER, 3/8 FLAT
68	5560005	2	ANCHOR BOLT
69	5560053	4	HEX JAM NUT, DRILLED
70	0111005	2	SPACER
71	5560649	6	M SCR, #10-24 X 1 LG, TRUSS HEAD
72	986009	6	WASHER, #10 FLAT
73	984049	6	NUT, #10-24 HEX
74	984469	4	NUT, 3/4-10 HEX JAM
75	5560170	4	WASHER, 3/4 HARD FLAT
76	5074401	2	BULKHEAD LOCKNUT
77	5034501	2	BLUKHEAD 90ELBOW
78	987099	4	WASHER, 1/4 MEDIUM LOCK
79	0070768	2	1/4 I.D. HOSE ASSY
80	970009	4	CAPSCREW, 1/4-20 X 1/2 LG HH PLATED
81	0110695	1	SLIDE PAD
82	0070639	2	SLIDE PAD
83	0110706	6	SHIM (.030)
84	0110701	2	SPACER
85	0110696	1	SLIDE PAD
86	0110702	2	SPACER
87	0110707	6	SHIM (.090)
88	0090141	10	SHIM (.090)
89	2504857		BEARING
90	5560684	4	WASHER, 7/8 HARD FLAT ASTM F-436
91	5560685	4	NUT, 7/8-9 HEX JAM
92	0110976	2	SPACER
93	0110977	2	SPACER
94	3070262	2	CONDUIT COUPLER, 1/2
95	3040187	2	CONNECTOR
96	0073111		SLIDE PAD SPACER
97	0080294	2	SLIDE PAD
98	0070043	2	SHIM (.030)
99	0073343	2	SHIM (.090)
100	5560015	20	3/8 THREADED INSERT
101	2500035	2	SPACER
102	970159	2	BOLT, .25-20 X 3.50 LG HH
103	986019	2	WASHER FLAT .25
104	0111324	2	CABLE GUIDE
105	5560603	2	NUT-SERT .250-20
107	0112795	1	COVER
108	0112796	2	VALVE ASSEMBLY
109	0111103	1	SWVEL ANCHOR BRACKET
111	974759	2	SCREW, #10-24 X 2.00 LG RD HD
112	5560654	2	WASHER LOCK #10
114	3040070	2	LOCKNUT .50

## Boom Installation – CE

F

E

D

C

B

A

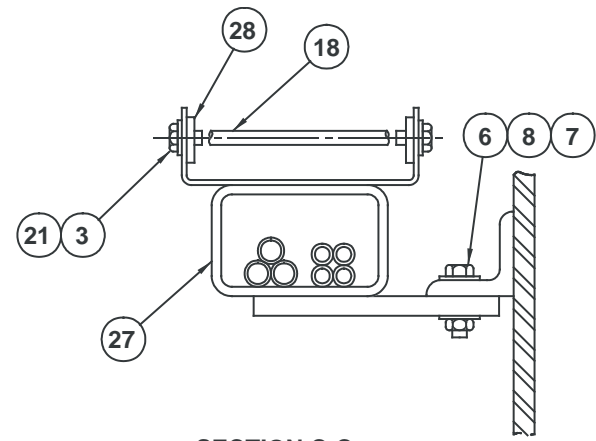

SECTION C-C

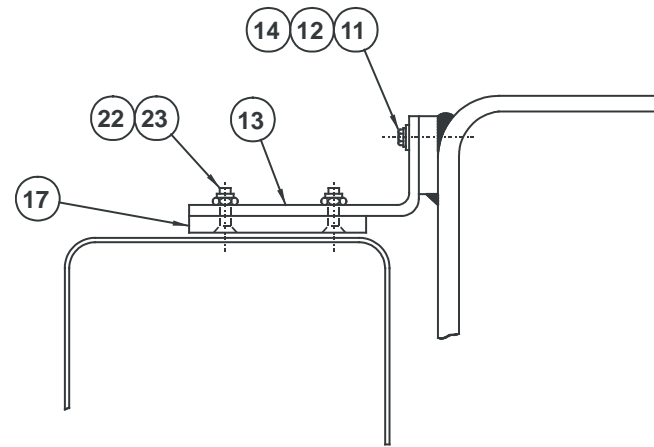

SECTION A-A

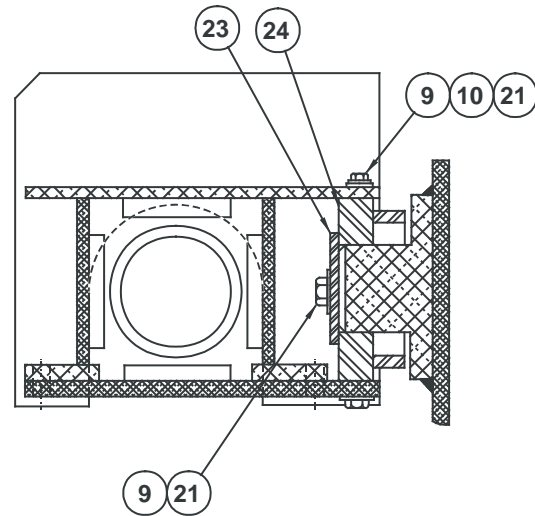

SECTION B-B

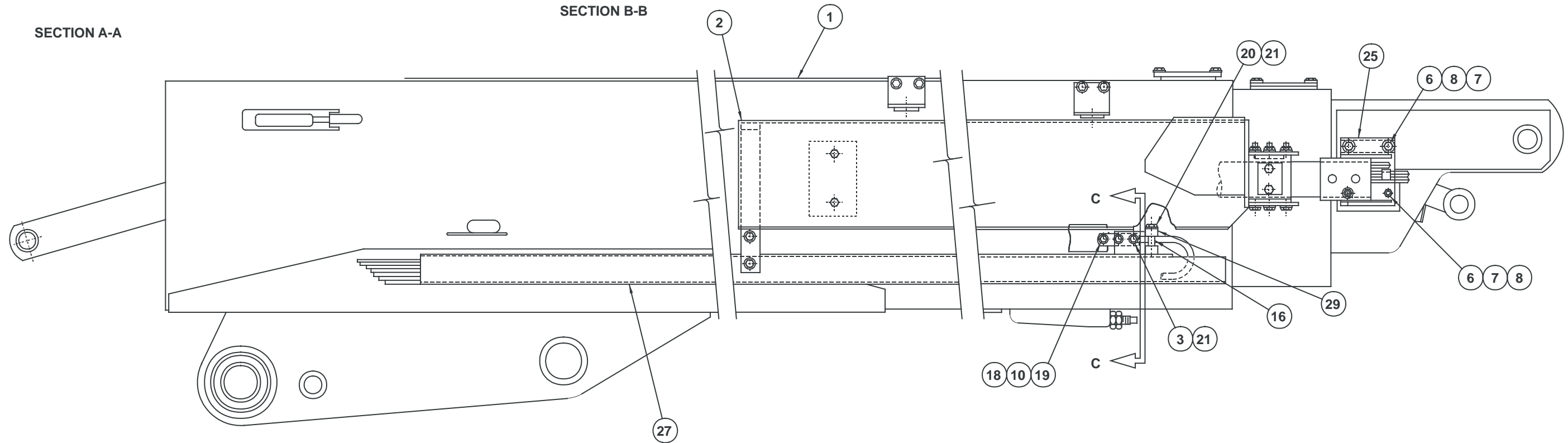
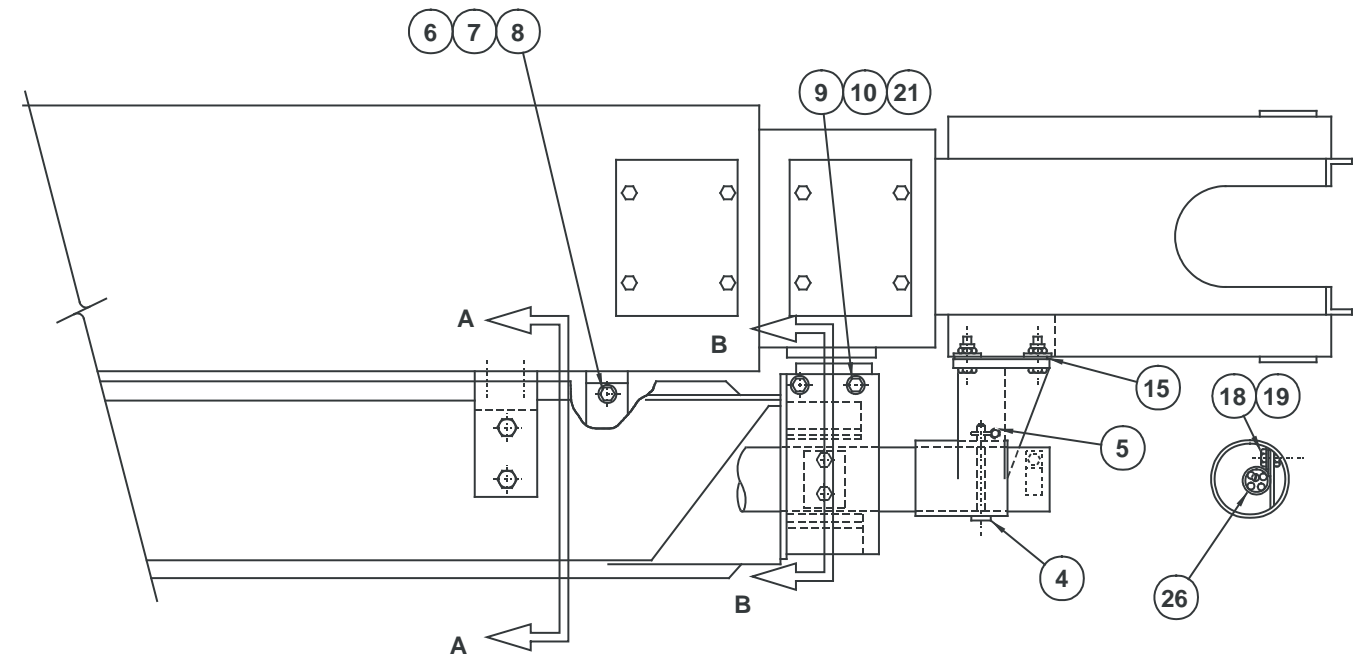

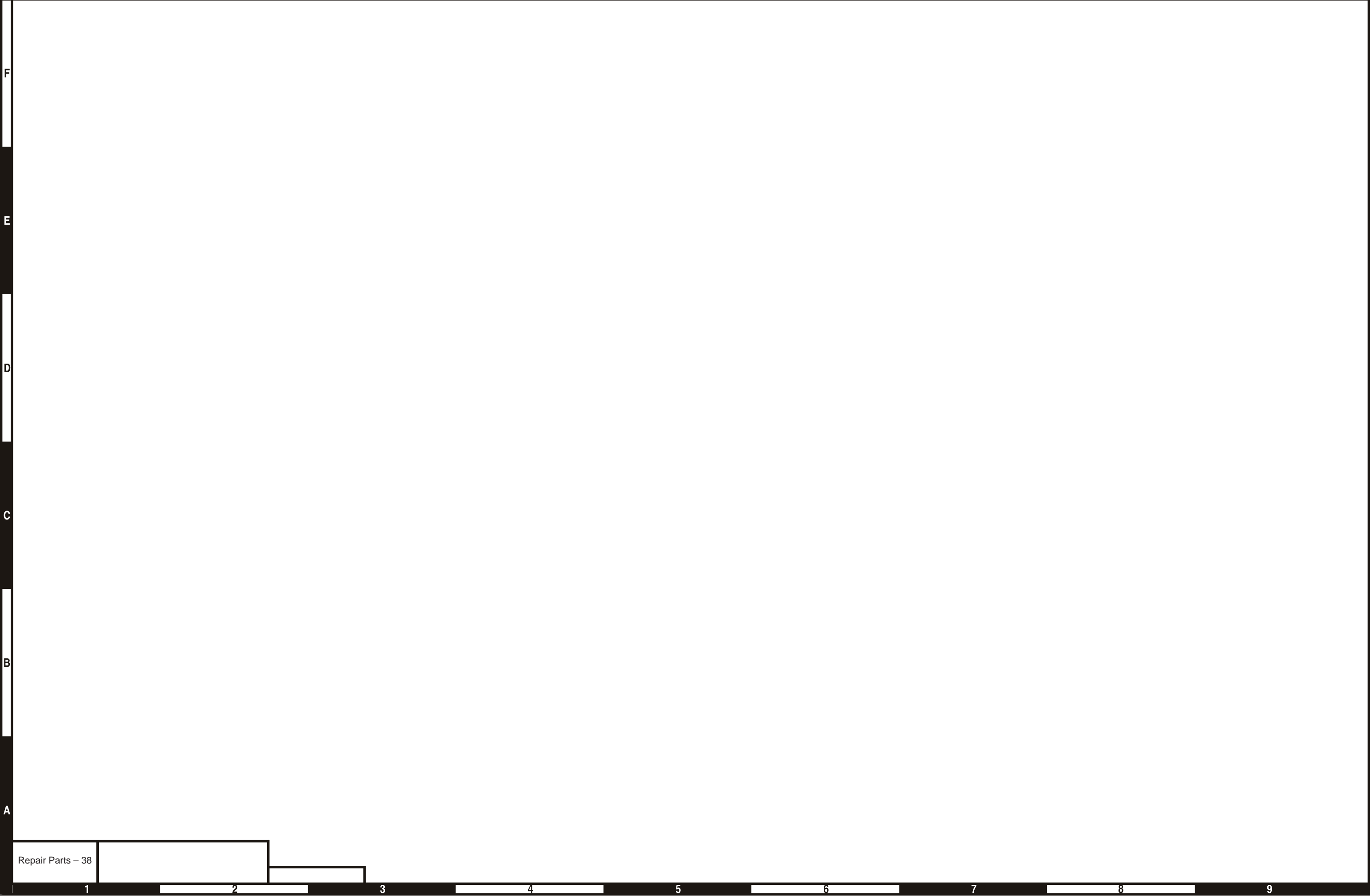

F

E

D

C

B

A

Repair Parts - 38

1

2

3

4

5

6

7

8

9

## Boom and Hose Carrier – TB80

Item	Part No.	Qty.	Description
1	0111896	1	BOOMS ASSEMBLY
2	0111951	1	HOSE CARRIER ASSEMBLY
3	970429	4	CAPSCREW, 3/8-16 X 1/2 LG HH GR5
4	0072015	1	CLEVIS PIN (5/8 DIA)
5	5560014	1	HAIR PIN (5/8 DIA. PIN)
6	970909	8	CAPSCREW 1/2-13 X 1 1/2 LG HH GR5
7	5560039	8	NUT, 1/2-13 ESNA
8	986359	8	WASHER 1/2 FLAT
9	970469	6	CAPSCREW 3/8-16 X 1 LG HH GR5
10	986299	6	WASHER 3/8 FLAT
11	970369	6	CAPSCREW 5/16-18 X 1 LG HH GR5
12	987109	8	WASHER 5/16 MED LOCK
13	0072951	2	GUIDE BAR
14	986019	6	WASHER 1/4 MED FLAT (5/16 I.D.)
15	0111120		SPACER
16	0110581	2	SPACER
17	0070029	2	SLIDE PAD
18	5560686	2	CAPSCREW 3/8-16 X 6 LG HH GR5
19	5560033	6	NUT 3/8-16 SELF LOCKING
20	970509	2	CAPSCREW 3/8-16 X 2 LG HH GR5
21	987119	12	WASHER 3/8 MED LOCK
22	972489	4	M. SCREW 3/8-16 X 1-1/2 LG FLAT HD SOC
23	0070506	1	PIN LOCK
24	0110602	1	PIN JOINT PLATE WELDMENT
25	0112071	1	TUBE BRACKET WELDMENT
26	5093027	1	CLAMP
27	0110840	1	SUPPORT TUBE WELDMENT
28	0110592	2	MOUNTING LUG
29	0110590	1	TUBE CLAMP, UPPER

## Boom and Hose Carrier – TB80





F  
E  
D  
C  
B  
A

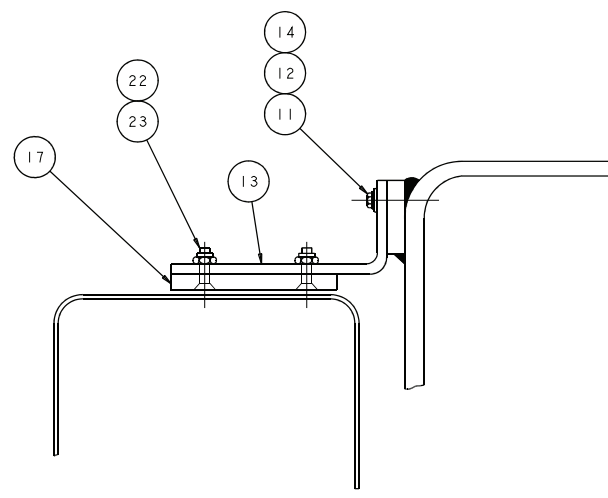

SECTION A-A

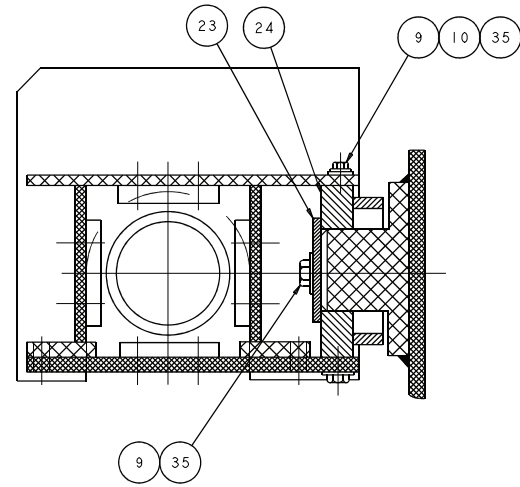

SECTION B-B

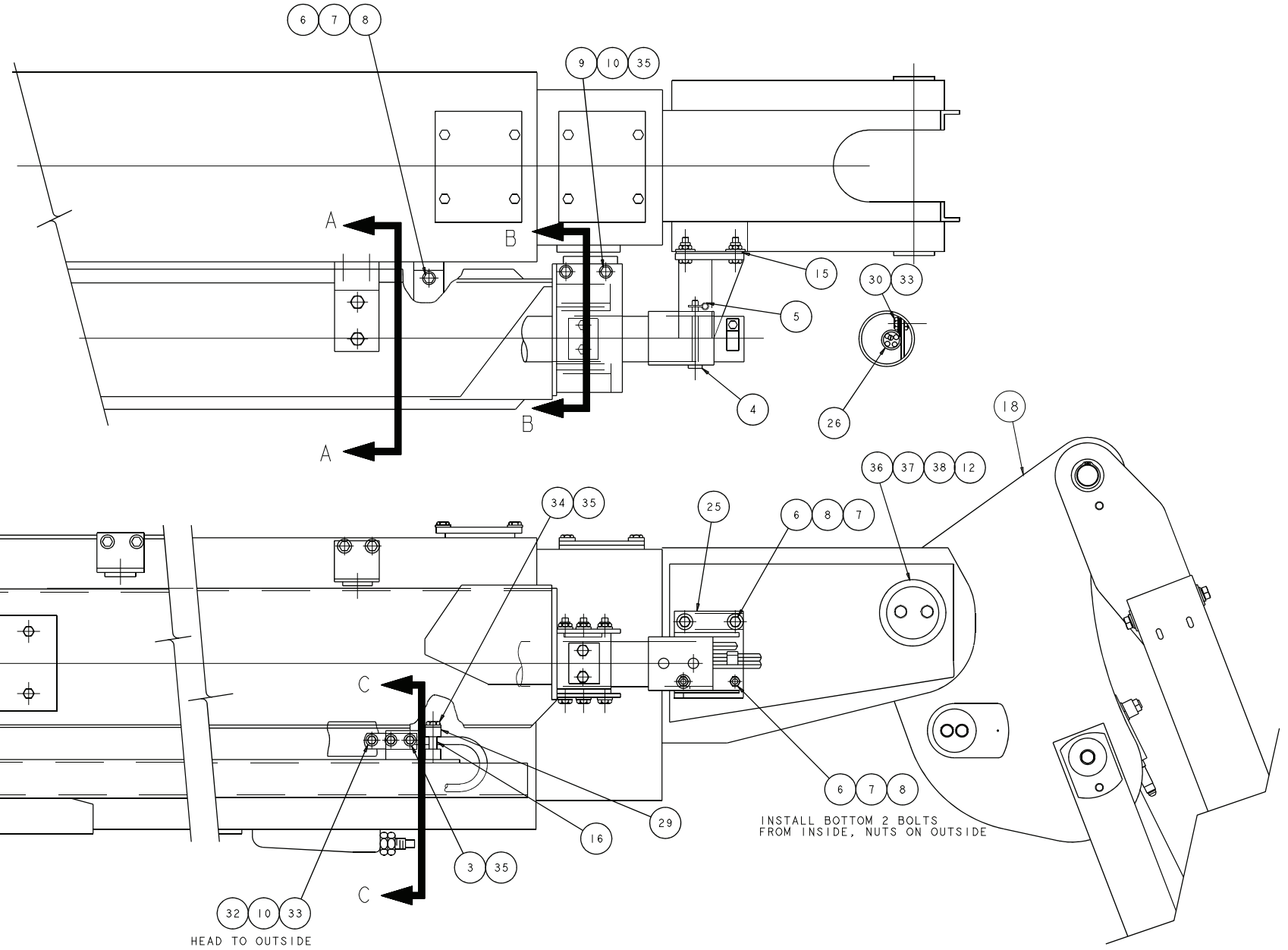

INSTALL BOTTOM 2 BOLTS FROM INSIDE, NUTS ON OUTSIDE

HEAD TO OUTSIDE

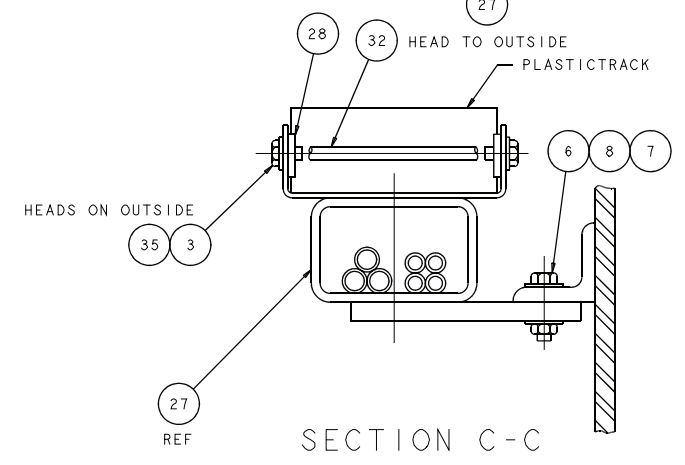

SECTION C-C

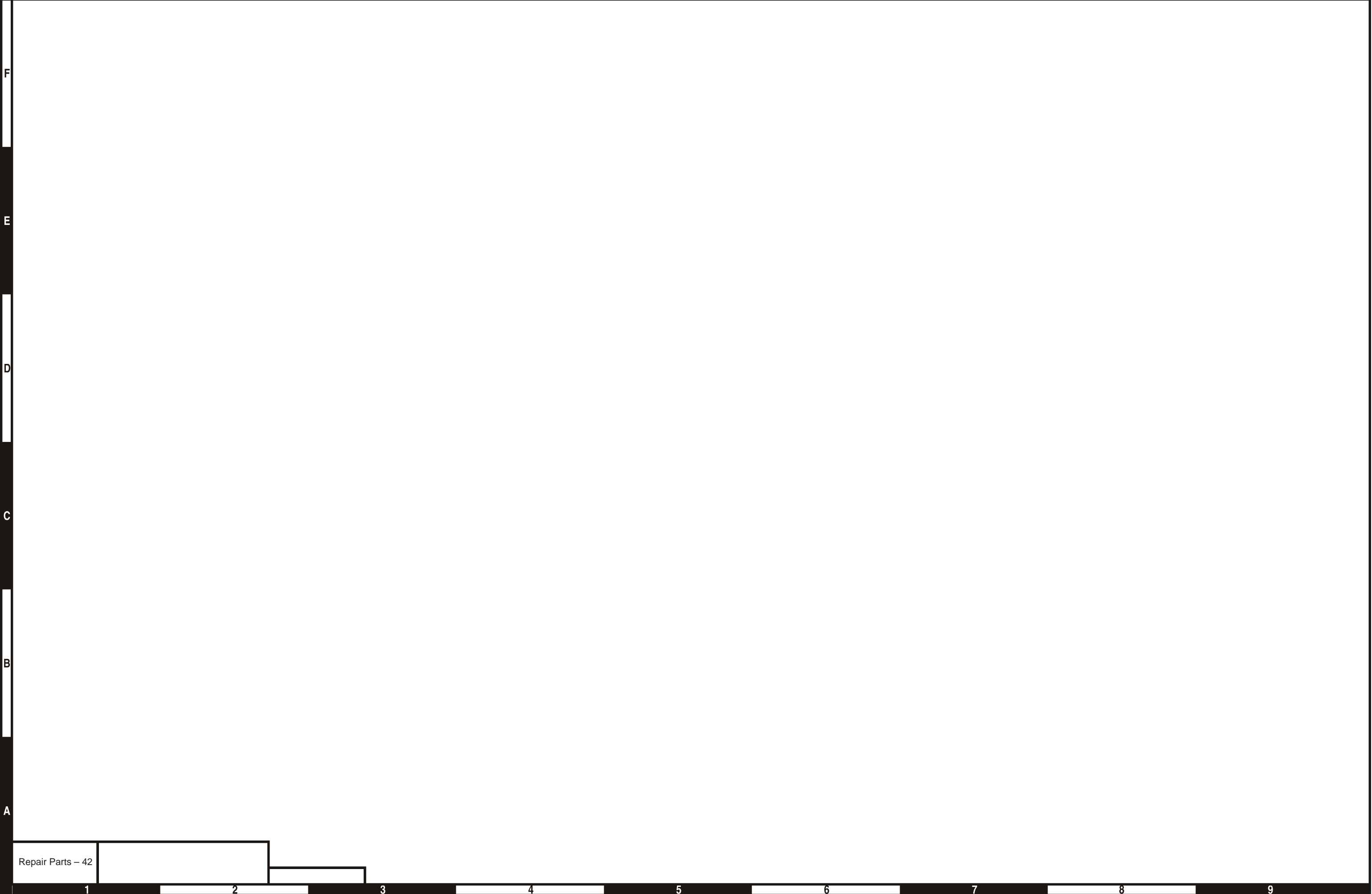

F

E

D

C

B

A

Repair Parts - 42

1

2

3

4

5

6

7

8

9

## Boom, Hose Carrier and Jib – TB85J

Item	Part No.	Qty.	Description
1	0112546	1	BOOMS ASSEMBLY
2	0112550	1	HOSE CARRIER ASSEMBLY
3	970429	4	CAPSCREW, 3/8-16 X 1/2 LG HH GR5
4	0072015	1	CLEVIS PIN (5/8 DIA)
5	5560014	1	HAIR PIN (5/8 DIA. PIN)
6	970909	8	CAPSCREW 1/2-13 X 1 1/2 LG HH GR5
7	5560039	8	NUT, 1/2-13 ESNA
8	986359	8	WASHER 1/2 FLAT
9	970469	6	CAPSCREW 3/8-16 X 1 LG HH GR5
10	986299	6	WASHER 3/8 FLAT
11	970259	6	CAPSCREW 5/16-18 X 1 LG HH GR5
12	987109	8	WASHER 5/16 MED LOCK
13	0072951	2	GUIDE BAR
14	986019	6	WASHER 1/4 MED FLAT (5/16 I.D.)
15	0111120		SPACER
16	0110581	2	SPACER
17	0070029	2	SLIDE PAD
18	0172220	1	ASSY, JIB
22	972489	4	M. SCREW 3/8-16 X 1-1/2 LG FLAT HD SOC
23	0070506	1	PIN LOCK
24	0110602	1	PIN JOINT PLATE WELDMENT
25	0112071	1	TUBE BRACKET WELDMENT
26	5093009	1	CLAMP
27	0110840	1	SUPPORT TUBE WELDMENT
28	0110592	2	MOUNTING LUG
29	0110590	1	TUBE CLAMP, UPPER
30	5560686	1	CAPSCREW 3/8-16 X 1-1/2 X 6 LG HH GR5
32	970469	1	CAPSCREW 3/8-16 X 1 LG HH GR5
33	5560033	6	NUT 3/8-16 ESNA
34	970509	2	CAPSCREW 3/8-16 X 2 LG HH GR5
35	986299	12	WASHER, 3/8 MED LOCK
36	0110678	1	PIN
37	0070132	1	PIN LOCK
38	0070473	2	BLT .313-18 DRILLED HD

## Boom, Hose Carrier and Jib – TB85J



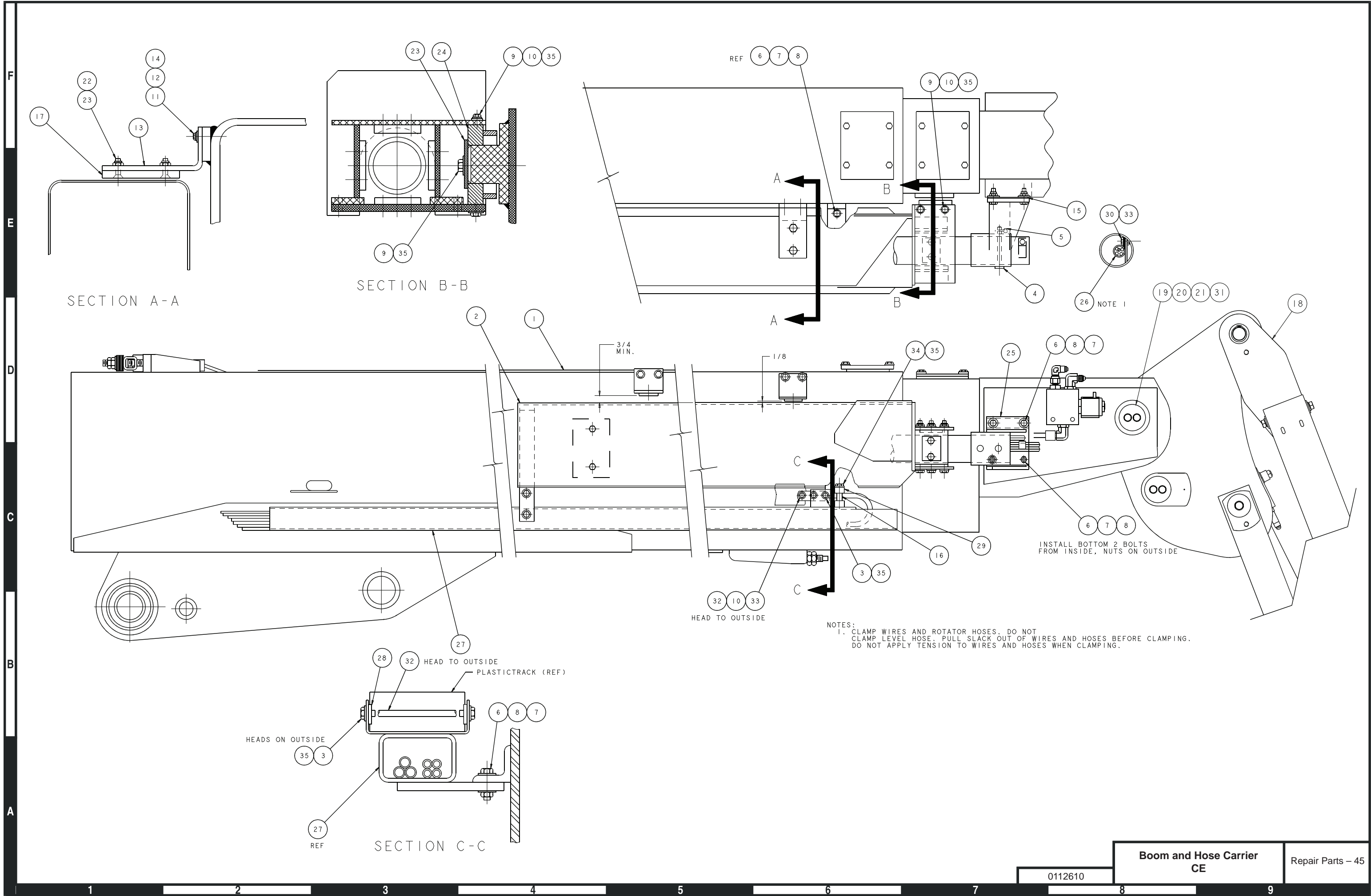

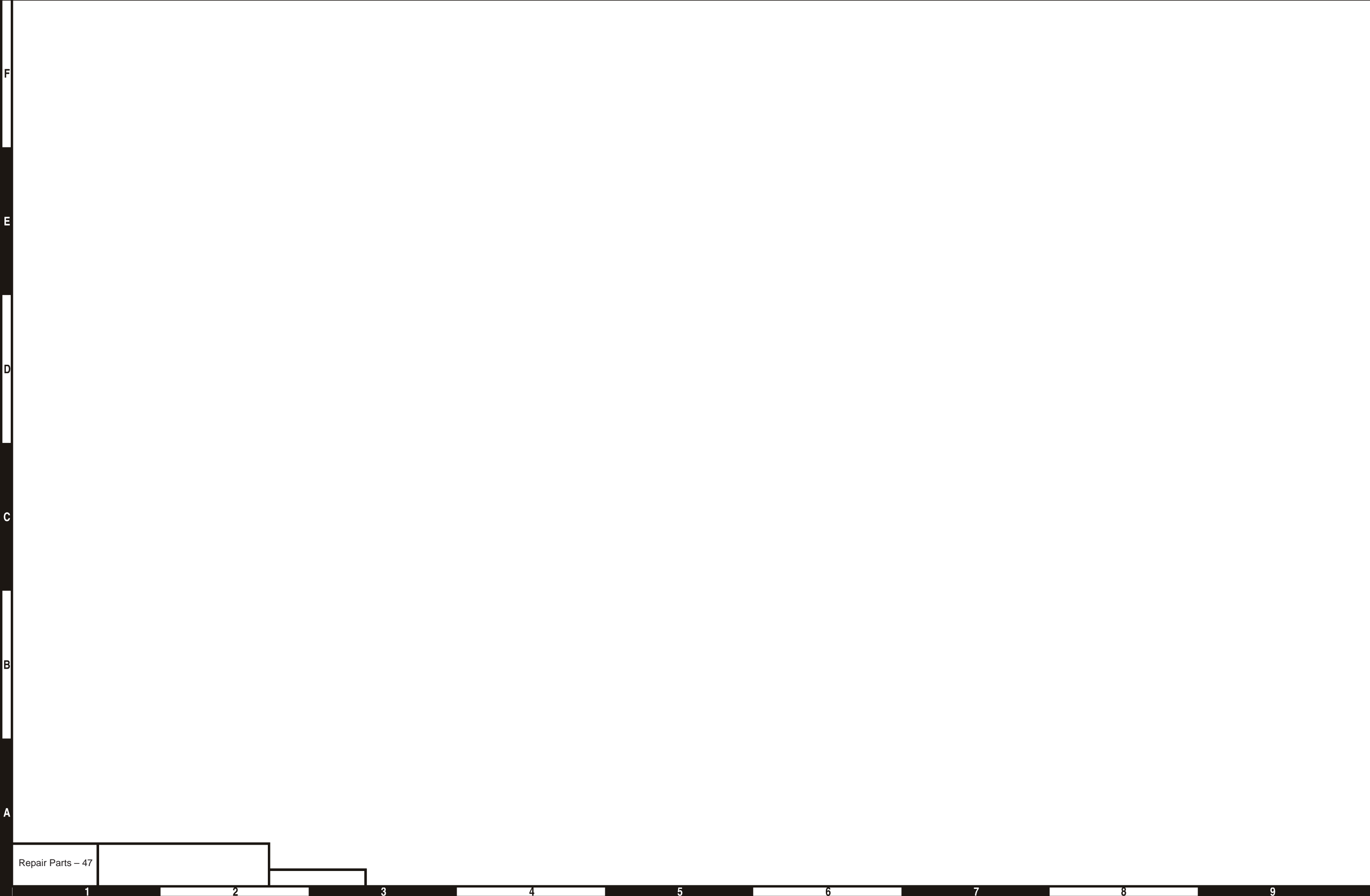

F

E

D

C

B

A

Repair Parts - 47

1

2

3

4

5

6

7

8

9

## Boom and Hose Carrier – CE

Item	Part No.	Qty.	Description
1	0112611	1	BOOMS ASSEMBLY
2	0112550	1	HOSE CARRIER ASSEMBLY
3	970429	4	CAPSCREW, 3/8-16 X 1/2 LG HH GR5
4	0072015	1	CLEVIS PIN (5/8 DIA)
5	5560014	1	HAIR PIN (5/8 DIA. PIN)
6	970909	8	CAPSCREW 1/2-13 X 1 1/2 LG HH GR5
7	5560039	8	NUT, 1/2-13 ESNA
8	986359	8	WASHER 1/2 FLAT
9	970469	6	CAPSCREW 3/8-16 X 1 LG HH GR5
10	986299	6	WASHER 3/8 FLAT
11	970259	6	CAPSCREW 5/16-18 X 1 LG HH GR5
12	987109	8	WASHER 5/16 MED LOCK
13	0072951	2	GUIDE BAR
14	986019	6	WASHER 1/4 MED FLAT (5/16 I.D.)
15	0111120		SPACER
16	0110581	2	SPACER
17	0070029	2	SLIDE PAD
18	0172220	1	ASSY, JIB
19	0110678	1	PIN WELDMENT
20	0070132	1	PIN LOCK
21	0070473	2	BOLT, DRH .313-18 X .75 LG HH
22	972489	4	M. SCREW 3/8-16 X 1-1/2 LG FLAT HD SOC
23	0070506	1	PIN LOCK
24	0110602	1	PIN JOINT PLATE WELDMENT
25	0112071	1	TUBE BRACKET WELDMENT
26	5093009	1	CLAMP
27	0110840	1	SUPPORT TUBE WELDMENT
28	0110592	2	MOUNTING LUG
29	0110590	1	TUBE CLAMP, UPPER
30	972489	1	CAPSCREW 3/8-16 X 1-1/2 LG HH GR5
31	9980012		.040 DIA SS SAFETY LOCKWIRE
32	5560686	1	CAPSCREW 3/8-16 X 6 LG HH GR5
33	5560033	6	NUT 3/8-16 ESNA
34	970509	2	CAPSCREW 3/8-16 X 2 LG HH GR5
35	986299	12	WASHER, 3/8 MED LOCK

## Boom and Hose Carrier – CE





F  
E  
D  
C  
B  
A

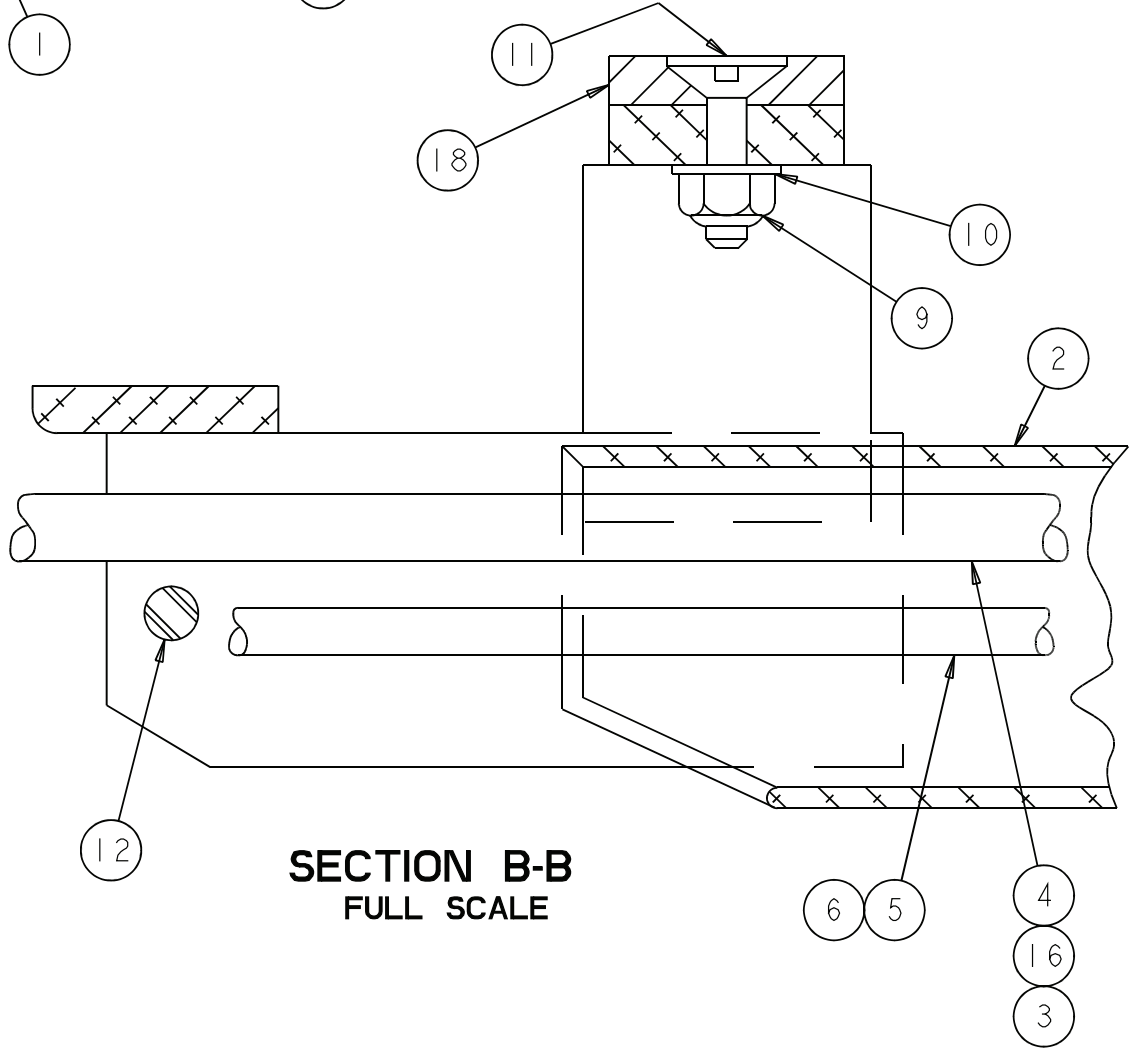
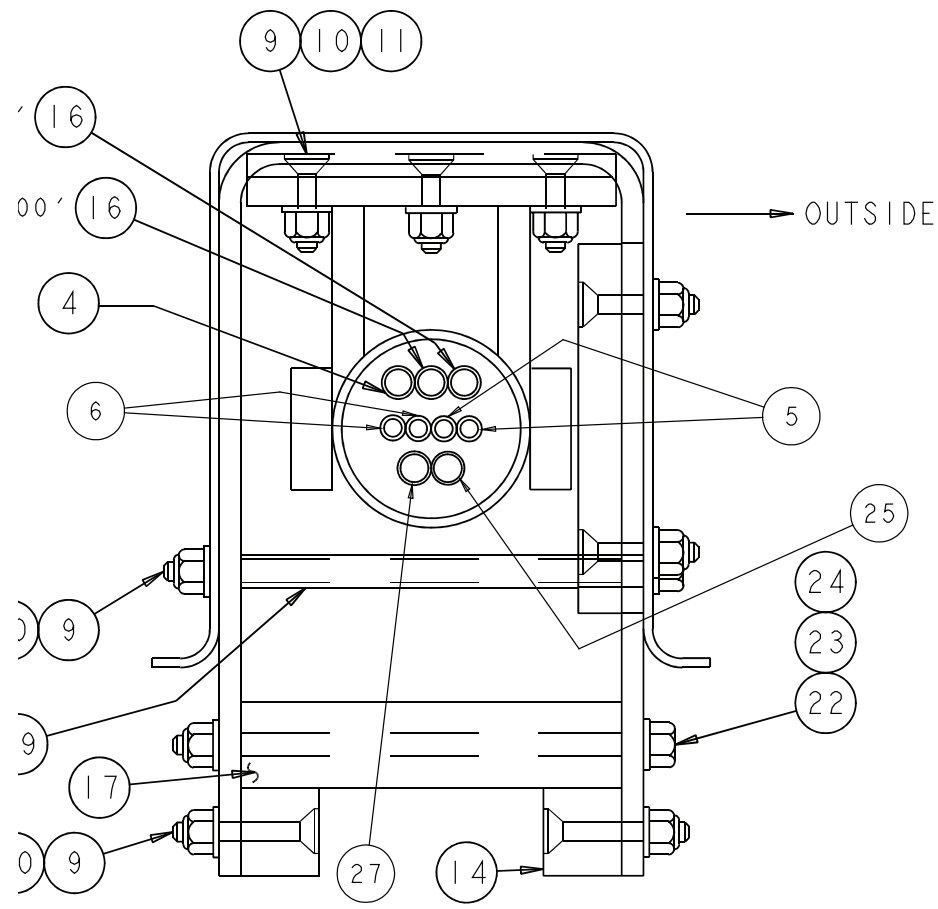
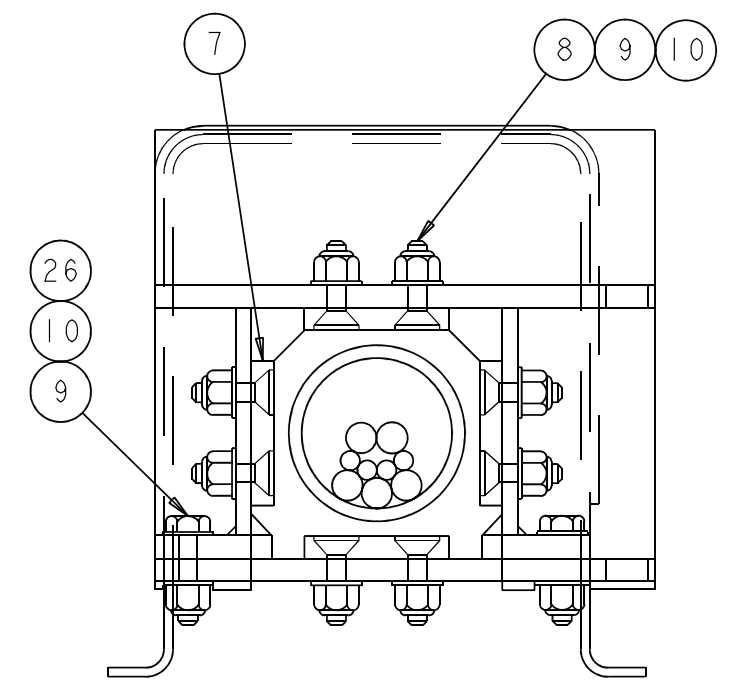
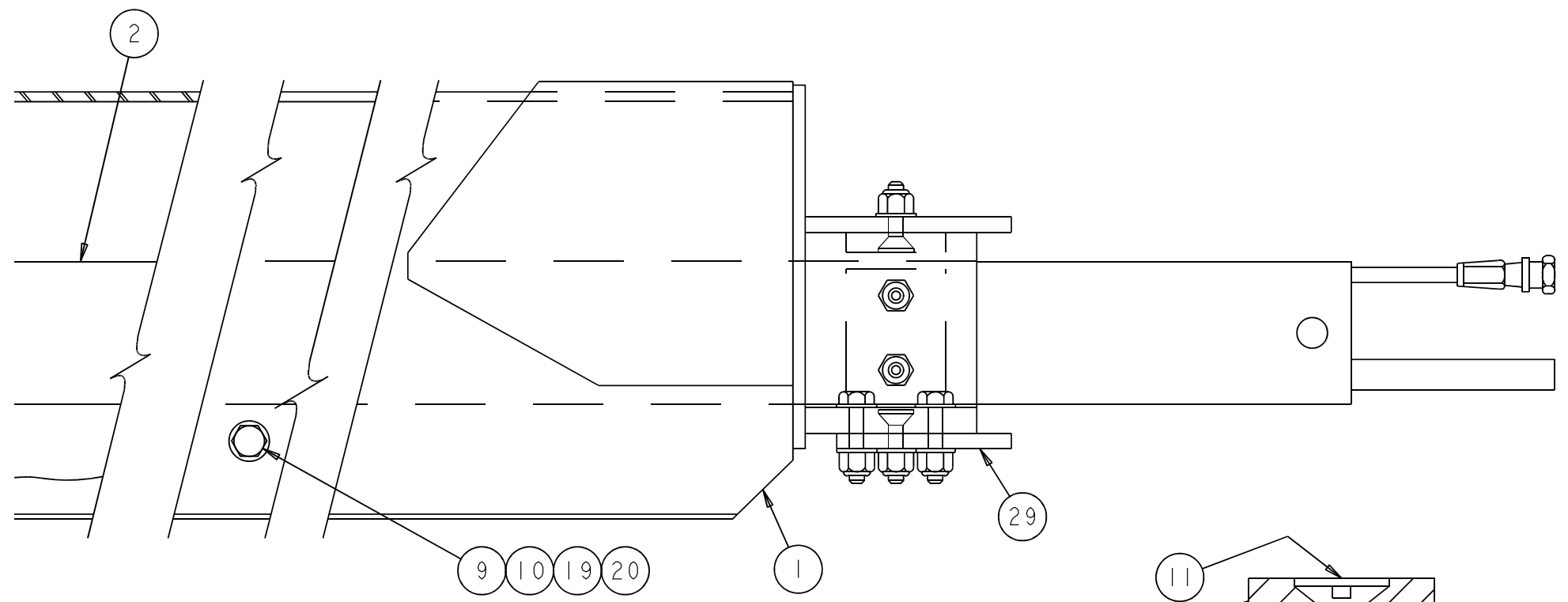

**SECTION B-B**  
FULL SCALE

**VIEW A-A**

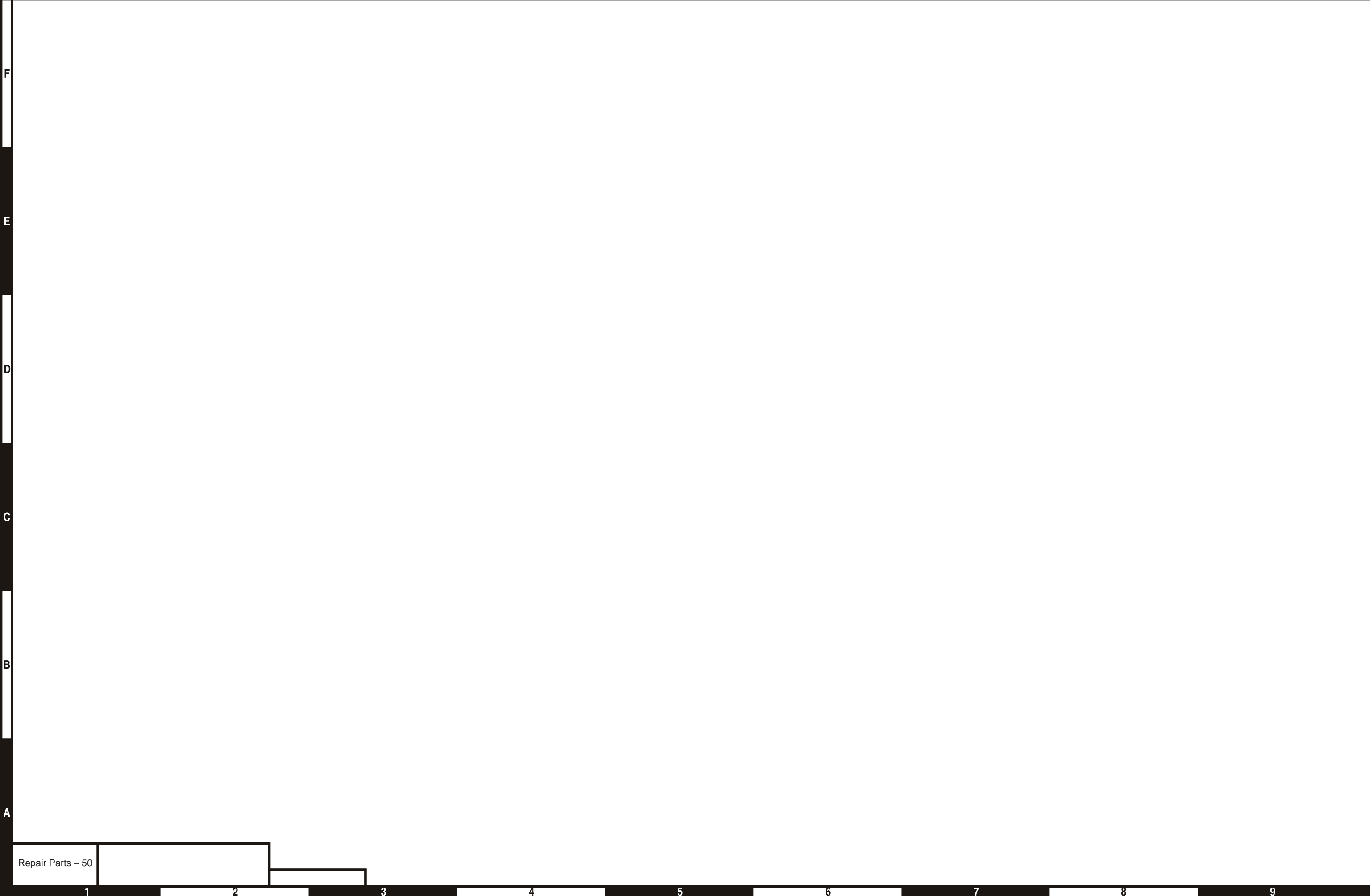

F

E

D

C

B

A

Repair Parts - 50

1

2

3

4

5

6

7

8

9

## Hose Carrier Assembly – TB80

Item	Part No.	Qty.	Description
1	0110206	1	HOSE CARRIER WELDMENT
2	0110571	1	CARRIER TUBE WELDMENT
4	3010006	100 FT	WIRE, 12/8 COND
5	0110219	2	3/16 ID HOSE ASSY (LEVELING)
6	0111957	2	3/16 ID HOSE ASSY (PLAT ROTATOR)
7	0100105	4	SLIDE PAD
8	5560644	8	BLT FLSKTHD 3/8-16 1.25 LG
9	5560033	29	NUT, 3/18-16, ESNA #22NE-066
10	986299	43	WASHER, 3/8 FLAT
11	978409	5	BLT FLSKTHD 3/8-16 1.5 LG
12	0110583	1	PIN
13	988169	2	COTTER PIN, 1/8 X 3/4 LG
14	0110583	2	SLIDE PAD
15	5560681	2	BLT FLSKTHD 3/8-16 X 2.25 LG
16	3010005	200 FT	WIRE 18/19 COND
17	0110841	1	SLIDE PAD
18	0070031	1	SLIDE PAD
19	0110227	10	SPACER
20	970639	10	BLT HEXHD 3/8-16 X 8 LG GR5
21	9920017	118	PLASTITRAK (118 LINKS)
22	5560687	1	BLT HEXHD 1/2-13 X 8 LG GR5
23	986359	2	WASHER, 1/2 FLAT
24	5560039	1	NUT, 1/2-13, ESNA #22NE-GR5
25	5010024	100 FT	HOSE 1/2 ID AIR HOSE
26	970529	4	BLT HEXHD 3/8-16 X 2.5 LG GR5
27	3011005	100 FT	WIRE 10/3 COND
28	0110603	1	SLIDE PAD
29	0110610	1	ANCHOR PLATE, BOTTOM

## Hose Carrier Assembly – TB80



F

E

D

C

B

A

ONE EACH SIDE

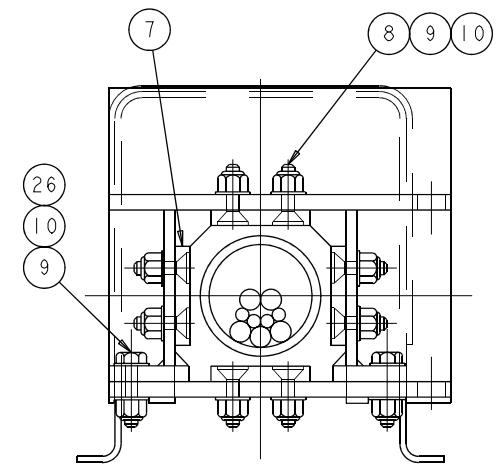
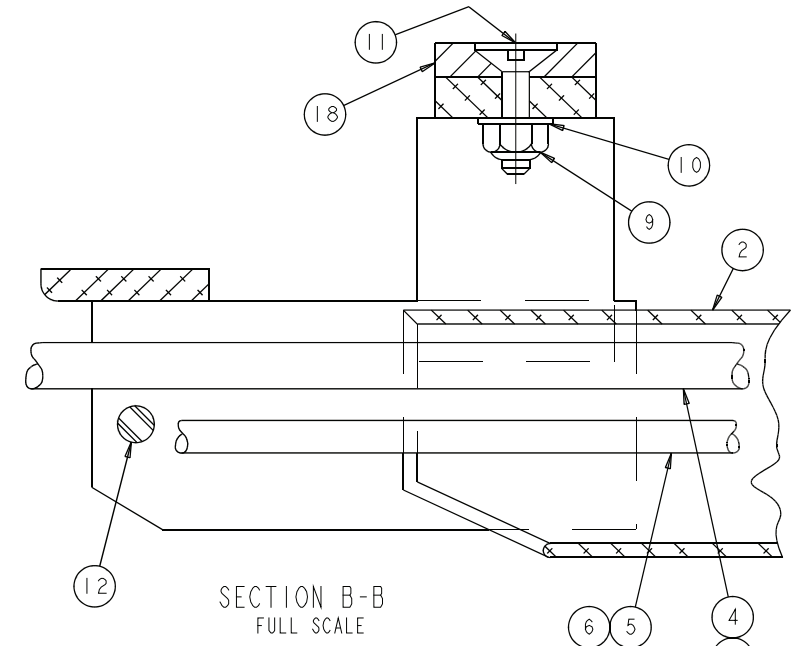
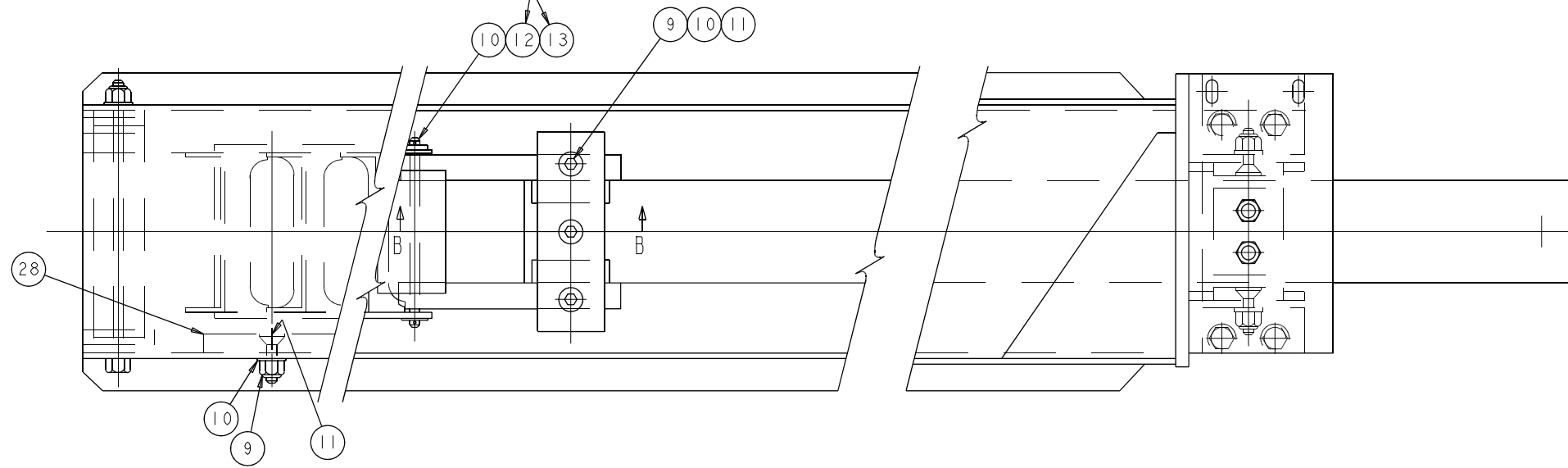

ITEMS 9, 10, 11 & 28 NOT SHOWN IN THIS VIEW

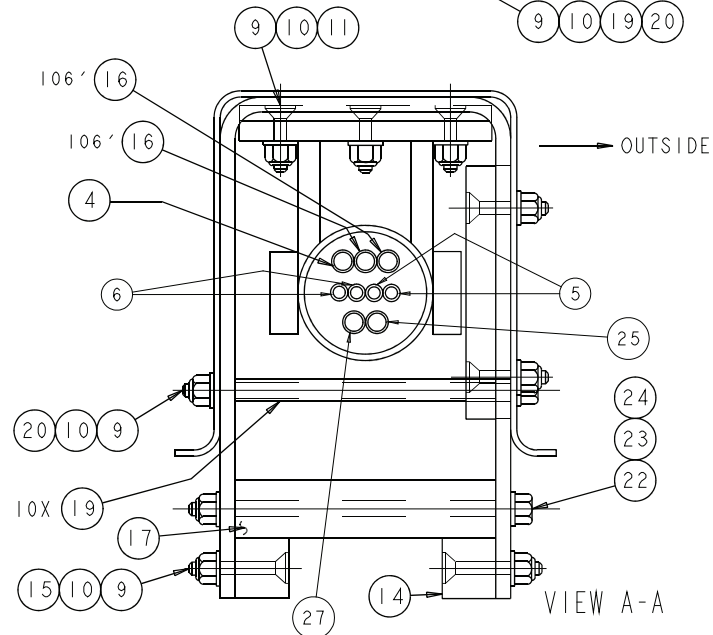
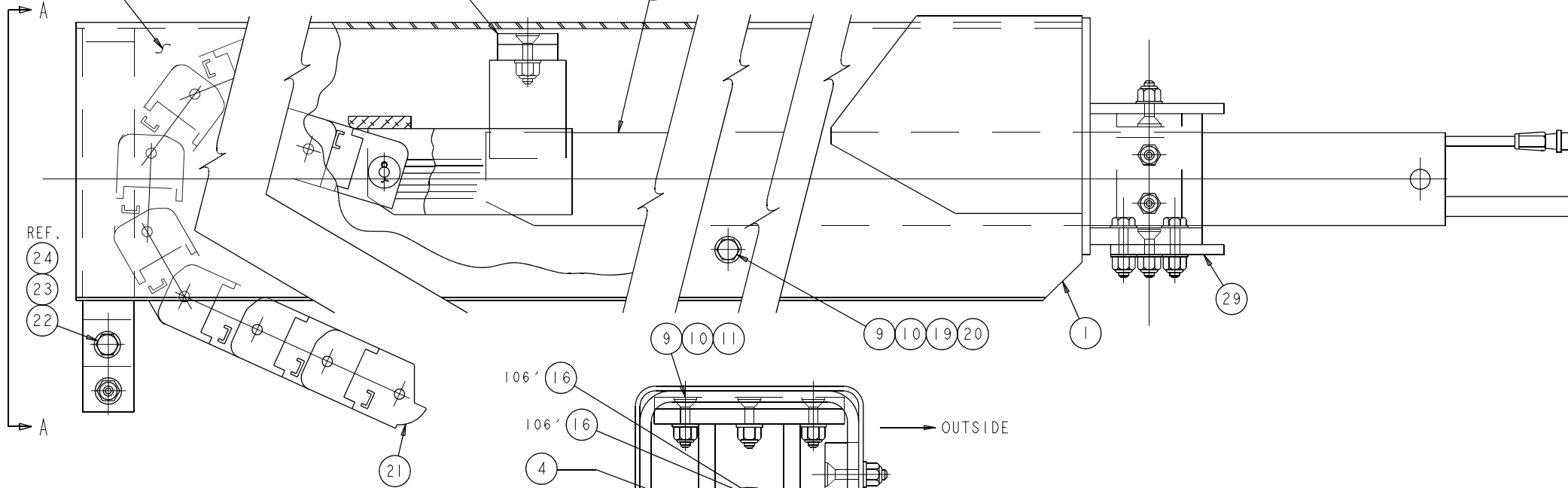

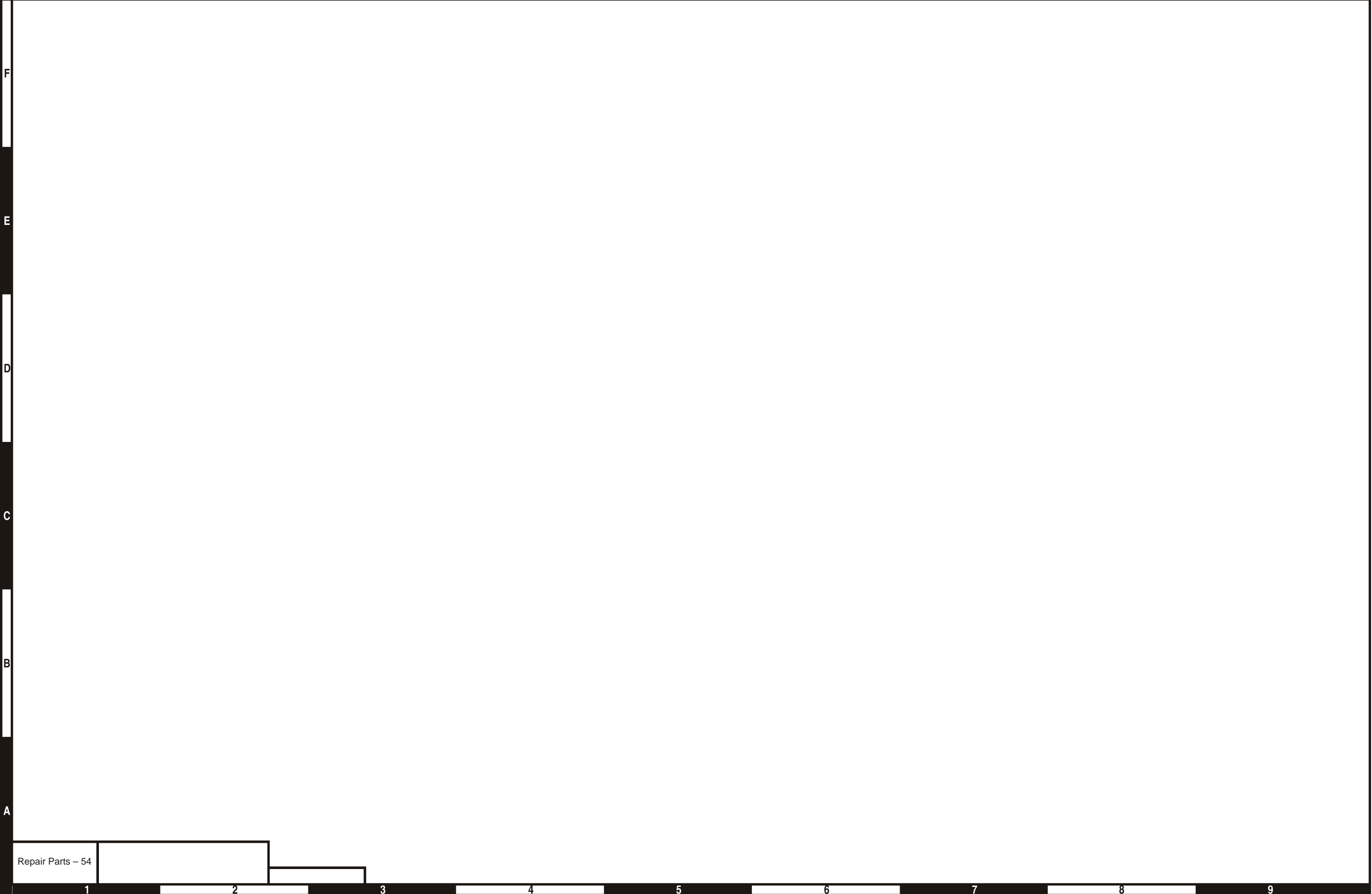

F

E

D

C

B

A

Repair Parts – 54

1

2

3

4

5

6

7

8

9

## Hose Carrier Assembly – TB85J

Item	Part No.	Qty.	Description
1	0110206	1	HOSE CARRIER WELDMENT
2	0110571	1	CARRIER TUBE WELDMENT
4	3010006	106 FT	WIRE, 12/8 COND
5	0110219	2	3/16 ID HOSE ASSY (LEVELING)
6	0112549	2	1/4 ID HOSE ASSY (PLAT ROTATOR)
7	0100105	4	SLIDE PAD
8	5560644	8	BLT FLSKTHD 3/8-13 1.25 LG
9	5560033	29	NUT, 3/18-16, ESNA
10	986299	43	WASHER, 3/8 FLAT
11	978409	5	BLT FLSKTHD 3/18-16 1.5 LG
12	0110583	1	PIN
13	988169	2	COTTER PIN, 1/8 X 3/4 LG
14	0110842	2	SLIDE PAD
15	5560681	2	BLT FLSKTHD 3/8-16 X 2.25 LG
16	3010005	212 FT	WIRE 18/19 COND
17	0110841	1	SLIDE PAD
18	0070031	1	SLIDE PAD
19	0110227	10	SPACER
20	970639	10	BLT HEXHD 3/8-16 X 8 LG GR5
21	9920017	118	PLASTITRAK (118 LINKS)
22	5560687	1	BLT HEXHD 1/2-13 X 8 LG GR5
23	986359	2	WASHER, 1/2 FLAT
24	5560039	1	NUT, 1/2-13, ESNA
25	5010024	104 FT	HOSE 1/2 ID AIR HOSE
26	970529	4	CAPSCREW 3/8-16 X 2.5 LG HEXHD GR5
27	3011005	106 FT	WIRE 10/3 COND
28	0110603	1	SLIDE PAD
29	0110610	1	ANCHOR PLATE, BOTTOM

## Hose Carrier Assembly – TB85J





# Jib – TB85J – Before 11/2007

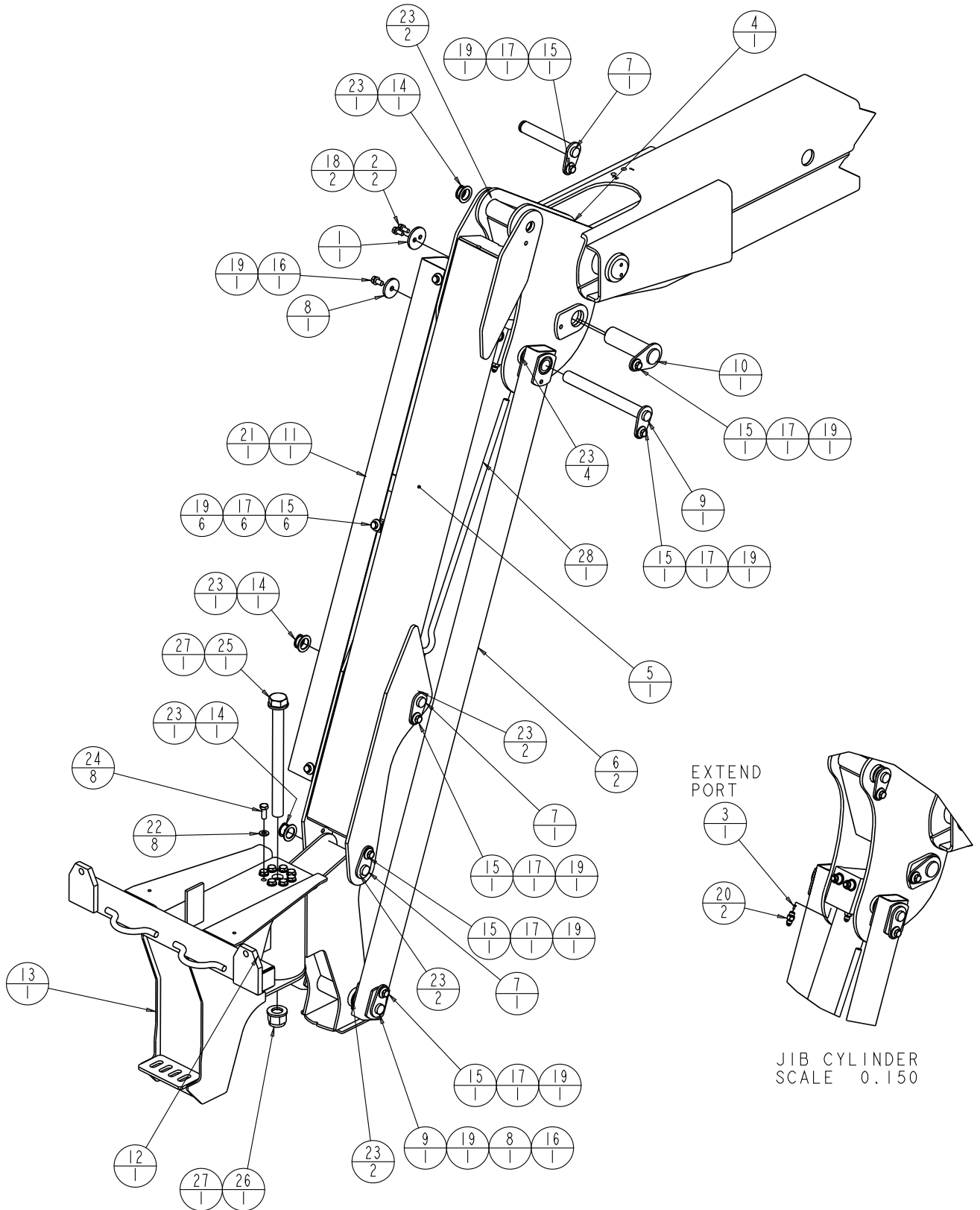

0172220

# Jib – TB85J – Before 11/2007

## Jib – TB85J – Before 11/2007

Item	Part No.	Qty.	Description
1	0070033	1	PIN LOCK
2	0070473	2	BLT .313-18 1.75GR DRILLED HOLE
3	0151918	1	ORIFICE .035
4	0172187	1	WLDMT, JIB INNER QUADRANT
5	0172195	1	UPPER JIB ARM, WELDMENT
6	0172199	2	LOWER JIB STRUT WELDMENT
7	0172213	3	PIN, TEARDROP, Ø1.0 X 5.79 GRIP
8	0172214	2	END CAP, 1 IN PIN
9	0172213	2	PIN, TEARDROP, Ø1.0 X 9.43 GRIP
10	0172228	1	PIN 1.50 DIA X 4.94 GRIP
11	0172231	1	COVER, HOSE 5' JIB
12	0172233	1	ASSY, ROTATOR
13	0172307	1	WLDMT, BASKET MTG BRKT
14	300542	3	SNAP RING 1.00 ID HEAVY DUTY
15	970439	12	BLT .375-16 .625
16	970449	2	BLT .375-16 .750 GR5
17	986299	12	WASHER FLAT .38
18	987109	2	WASHER LOCK .313
19	987119	14	WASHER LOCK .375
20	5065703	2	FTG ADPTR STRTHD-4B-4S STL
21	5560083	18 IN	TRIM LOC .125 RUBBER EDGE
22	5560222	8	WASHER HARD FLAT .375 SP
23	5560689	15	BSHG, MCHRY, 1.00 ID 1.5OD 14 GA
24	5563026	8	BLT 10MM-1.50P 25MM 10.9
25	5569989	1	BLT 24MM-3.00P 280MM 10.9
26	5569990	1	NUT LKG M24-3.OP
27	5569991	2	WASHER HARD FLAT M24
28	6047114	1	CLY, 31.53 LG, 24.45 STROKE
102	0172444	2	HOSE -4-4S-4S 93 100R1
106	0070772	2	HOSE -4-4S-4S 54 100R1

## Jib – TB85J – Before 11/2007

### Jib – Platform Rotator – Before 11/2007

Item	Part No.	Qty.	Description
1	017223328	1	PLATFORM ROTATOR - (ITEMS 1 THROUGH 5)
	0172188	1	HELAC ROTATOR
	8080152		SEAL KIT
	8080153		BEARING KIT
	8080154		HARDWARE KIT
	8080155		STOP TUBE
	8080156		COUNTERBALANCE VALVE ASSEMBLY
2	978419	3	BOLT SKTHD .25 - 20 1.50
3	2500060	4	BEARING 1.0 ID X 1.120 OD X 1.00 LG
4	5035303	2	FITTING ELBOW 90 STRTHD-4B-4S STL
5	6019089	1	VALVE DUAL COUNTERBALANCE

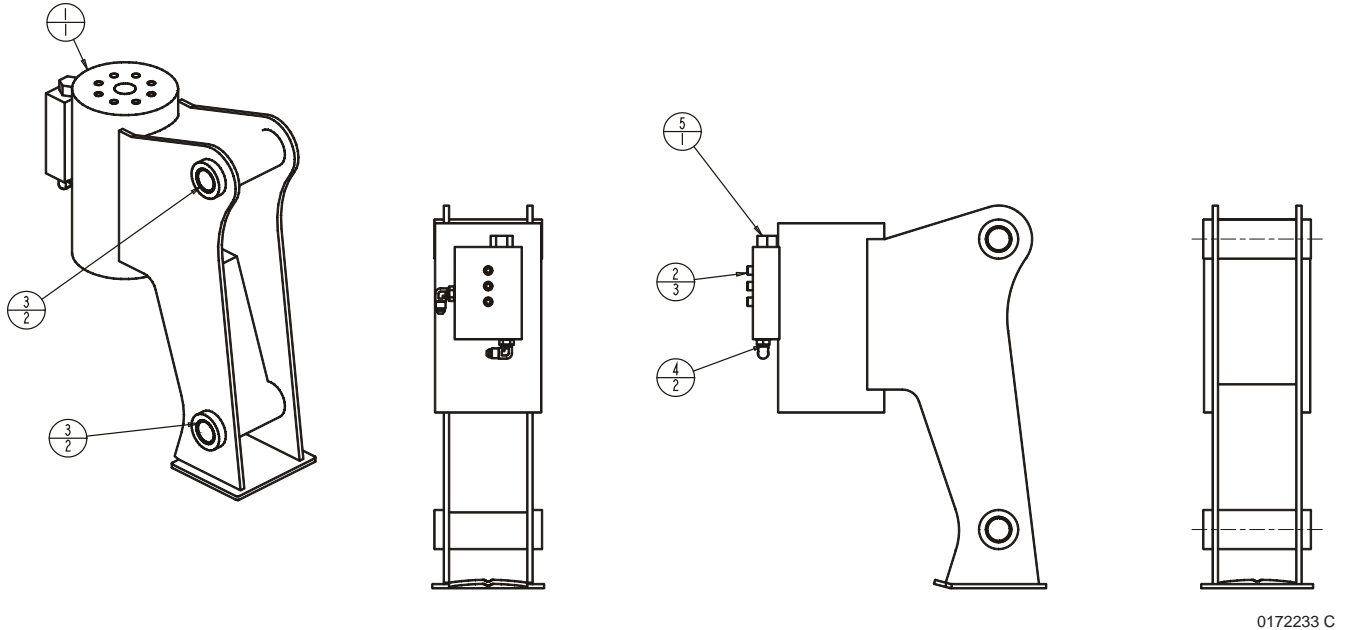

0172233 C

### Jib – Inner Quadrant – Before 11/2007

Item	Part No.	Qty.	Description
	0172187	1	JIB INNER QUADRANT - (INCLUDES ITEMS 1 AND 2)
1	2500060	4	BEARING 1.0 ID X 1.125 OD X 1.00 LG
2	2502832	2	BEARING 1.75 ID X 1.94 OD X 2.00 LG

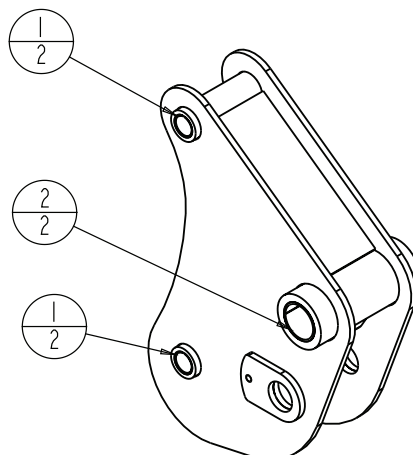

0172187 D



# Jib – TB85J – After 10/2007

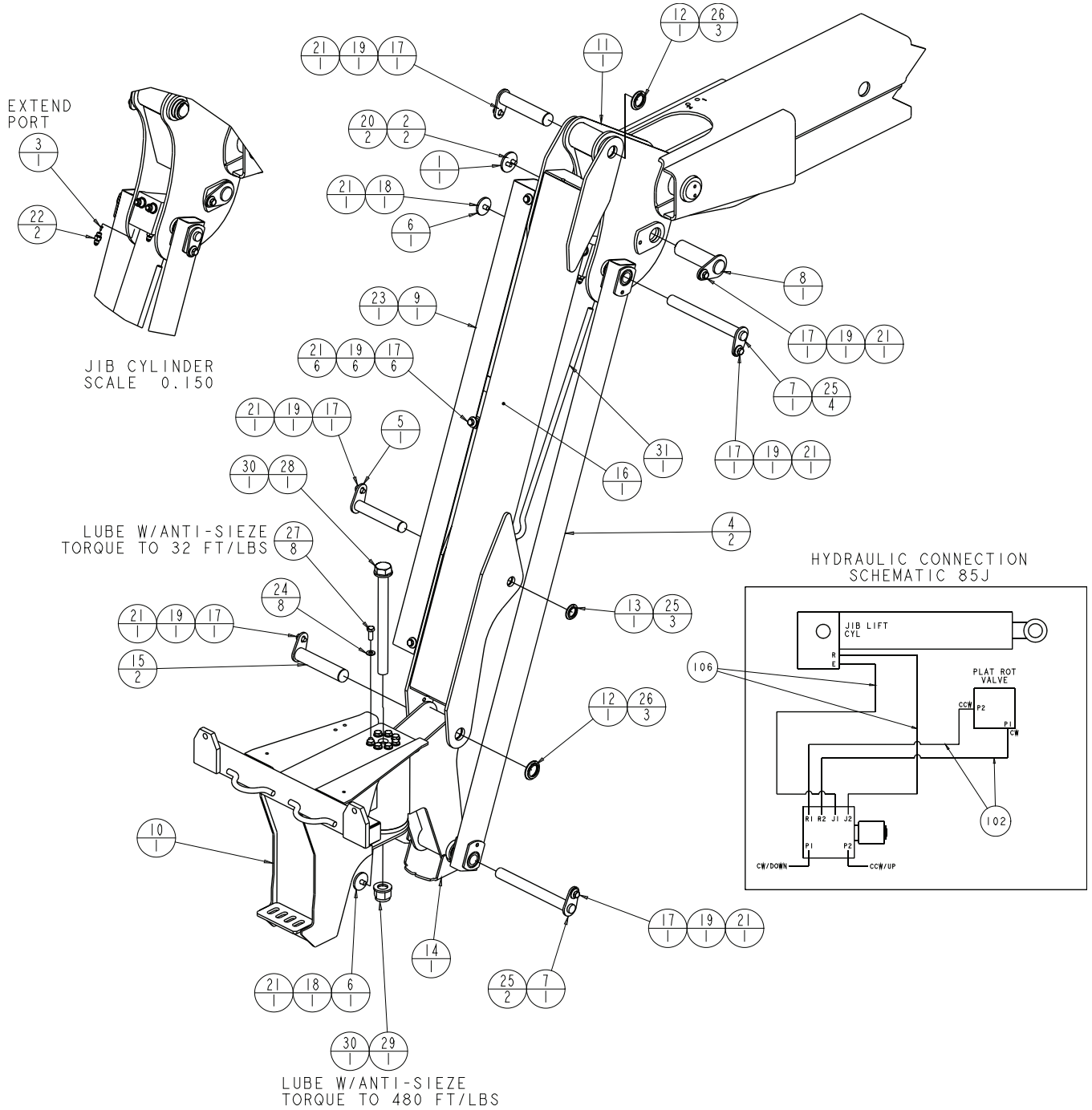

0172220

# Jib – TB85J – After 10/2007

## Jib – TB85J – After 10/2007

Item	Part No.	Qty.	Description
1	0070033	1	PIN LOCK
2	0070473	2	BLT .313-18 0.75 GR5 DRILLED HOLE
3	0151918	1	ORIFICE .035
4	0172199	2	LOWER JIB STRUT WELDMENT
5	0172213	3	PIN, TEARDROP, Ø1.0 X 5.79 GRIP
6	0172214	2	END CAP, 1 IN PIN
7	0172216	2	PIN, TEARDROP, Ø1.0 X 9.43 GRIP
8	0172228	1	PIN 1.50 DIA X 4.94 GRIP
9	0172231	1	COVER, HOSE 5' JIB
10	0172307	1	WLDMT, BASKET MTG BRKT
11	0172462	1	WLDMT, JIB INNER QUADRANT
12	300541	2	SNAP RING 1.25 ID HEAVY DUTY
13	300542	3	SNAP RING 1.00 ID HEAVY DUTY
14	0420114	1	ASSEMBLY, ROTATOR PLATFORM
15	0420124	2	PIN, TEARDROP, Ø1.25 X 5.79 GRIP
16	0420734	1	WLDMT, UPPER ARM 5' JIB
17	970439	12	BLT .375-16 .625
18	970449	2	BLT .375-16 .750 GR5
19	986299	12	WASHER FLAT .38
20	987109	2	WASHER LOCK .313
21	987119	14	WASHER LOCK .375
22	5065703	2	FTG ADPTR STRTHD-4B-4S STL
23	5560083	18 IN	TRIM LOC .125 RUBBER EDGE
24	5560222	8	WASHER HARD FLAT .375 SP
25	5560689	15	BSHG, MCHRY, 1.00 ID 1.5OD 14 GA
26	5560712	6	MACH BSHG 1.25 ID X 1.88 OD X .075
27	5563026	8	BLT 10MM-1.50P 25MM 10.9
28	5569989	1	BLT 24MM-3.00P 280MM 10.9
29	5569990	1	NUT LKG M24-3.OP
30	5569991	2	WASHER HARD FLAT M24
31	6047114	1	CLY, 31.53 LG, 24.45 STROKE
102	0172444	2	HOSE -4-4S-4S 93 100R1
106	0070772	2	HOSE -4-4S-4S 54 100R1

## Jib Boom – TB85J – After 10/2007

## Jib – Platform Rotator – After 10/2007

Item	Part No.	Qty.	Description
1	0420114	1	PLATFORM ROTATOR - (ITEMS 1 THROUGH 6)
	0420113	1	HELAC ROTATOR
	8080152		SEAL KIT
	8080153		BEARING KIT
	8080154		HARDWARE KIT
	8080155		STOP TUBE
	8080156		COUNTERBALANCE VALVE ASSEMBLY
2	978419	3	BOLT SKTHD .25 - 20 1.50
3	2500051	2	BEARING 1.25 ID X 1.50 OD X 1.50 LG
4	2509677	2	BEARING 1.00 ID X 1.50 OD X 1.50 LG
5	5035303	1	FITTING ELBOW 90 STRTHD-4B-4S STL
6	6019089	1	VALVE DUAL COUNTERBALANCE

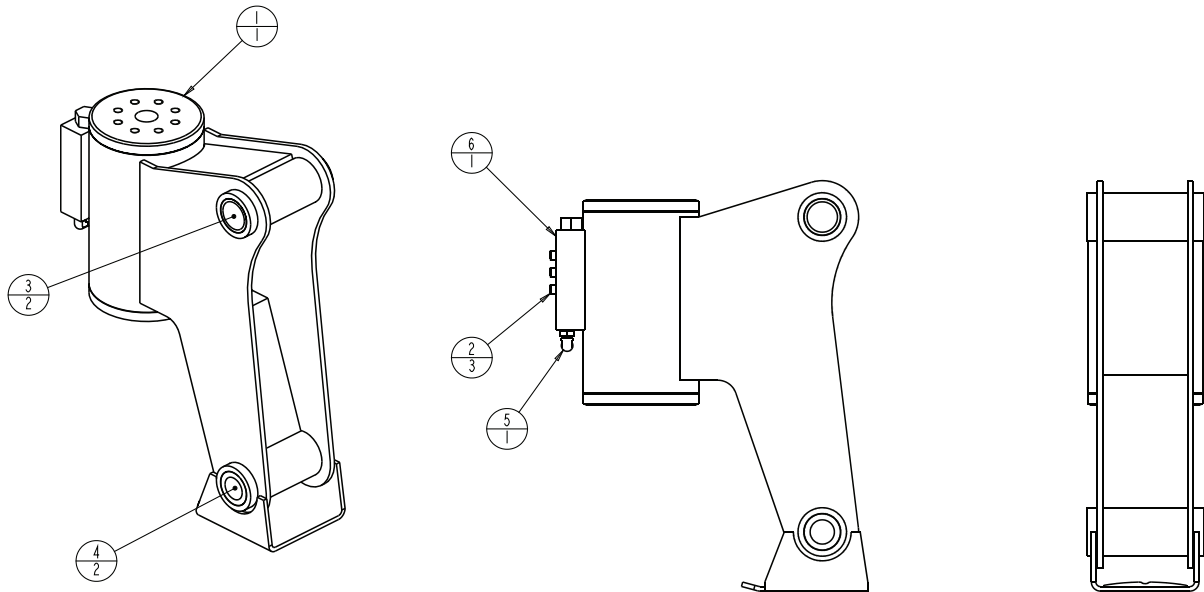

0420114 D

## Jib – Inner Quadrant – After 10/2007

Item	Part No.	Qty.	Description
	0172462	1	JIB INNER QUADRANT - (INCLUDES ITEMS 1 THROUGH 3)
1	2500035	2	BEARING 1.25 ID X 1.50 OD X 1.25 LG
2	2500060	2	BEARING 1.0 ID X 1.125 OD X 1.00 LG
3	2502836	2	BEARING 1.75 ID X 2.25 OD X 2.00 LG

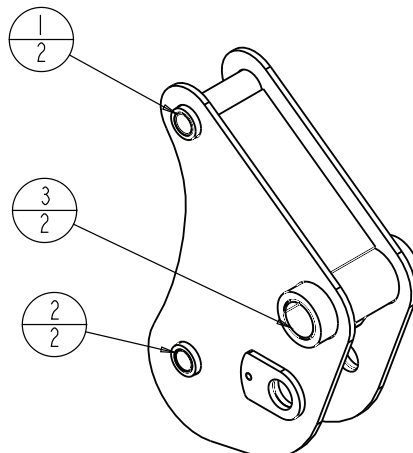

0172462 A





F

E

D

C

B

A

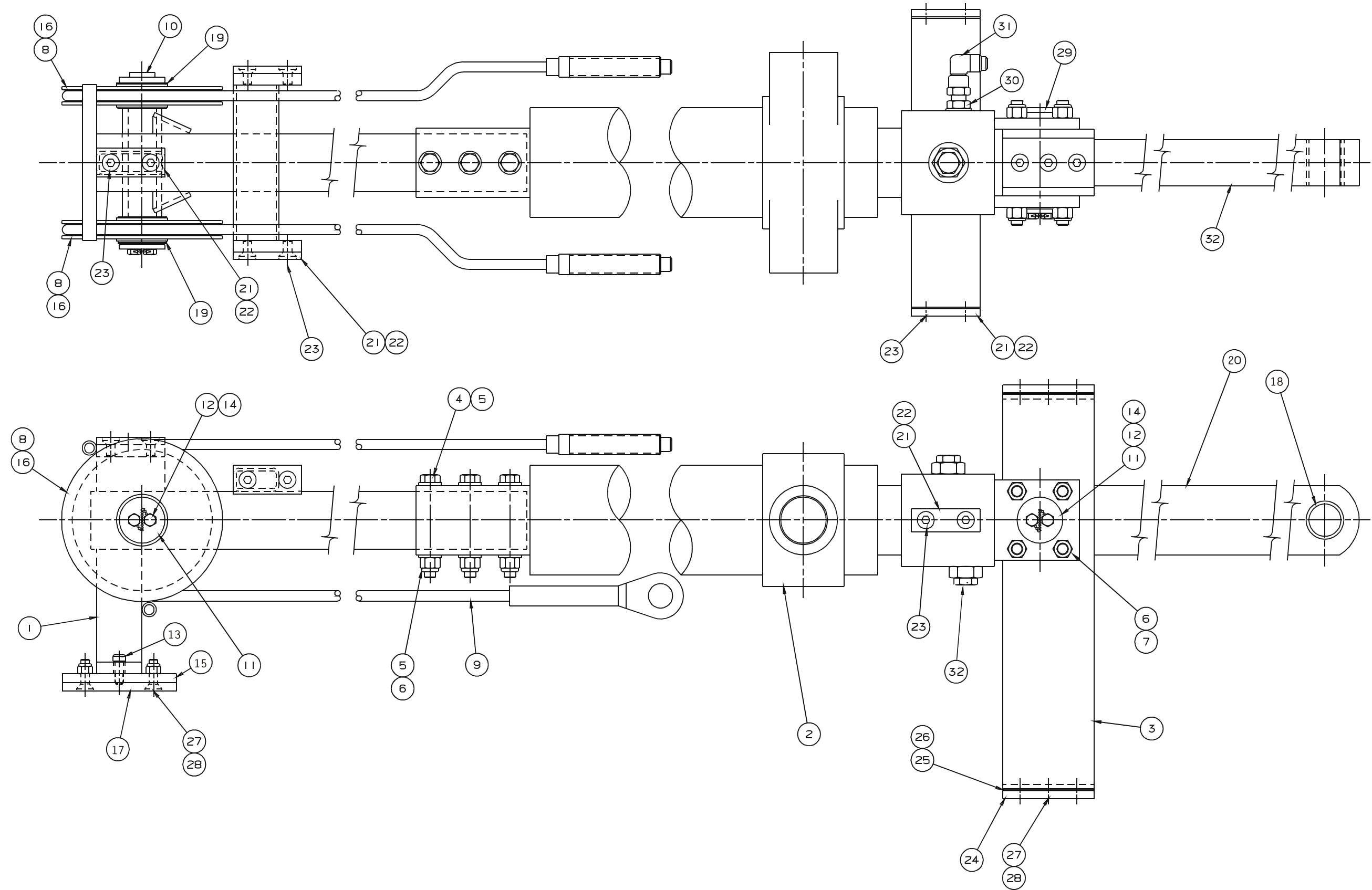

0110628

Extension Cylinder  
Mounting

Repair Parts - 61

1

2

3

4

5

6

7

8

9

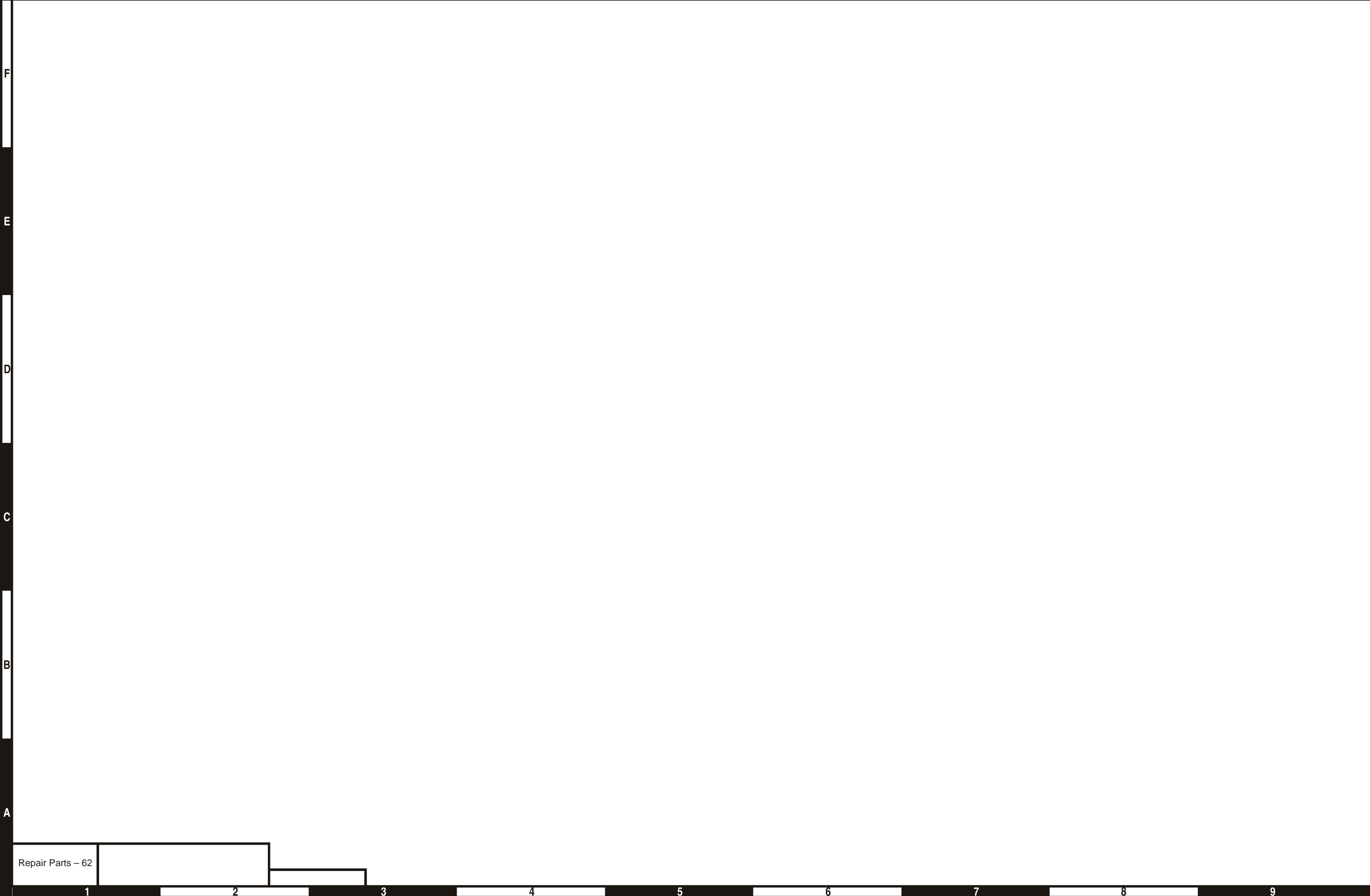

F

E

D

C

B

A

Repair Parts - 62

1

2

3

4

5

6

7

8

9

## Extension Cylinder Mounting

Item	Part No.	Qty.	Description
1	0111822	1	SUPPORT BRACKET, EXTEND CYLINDER BASE END
2	0110623	1	EXTENSION CYLINDER
3	0110647	1	SUPPORT BRACKET, EXTEND CYLINDER ROD END
4	971009	3	CAPSCREW, 1/2-13 X 4 LG HEXHD GR5
5	5560168	6	WASHER, 1/2 HARDENED FLAT ASTM-A325
6	5560039	11	NUT, 1/2-13 ESNA
7	970919	8	CAPSCREW, 1/2-13 X 1-3/4 LG FH SOCKET
8	0111701	2	SHEAVE, EXTEND CABLE
9	0112064	2	WIRE ROPE ASSEMBLY, EXTEND
10	0110645	1	PIN EXTEND SHEAVE
11	0070033	2	PIN LOCK
12	0070473	4	CAPSCREW, DRILLED HEAD
13	5560005	2	ANCHOR BOLT
14	9980012		.040 SS SAFETY LOCKWIRE
15	0191070	1	PLATE, SLIDE PAD MOUNTING
16	2502028	2	BEARING
17	0191071	1	SLIDE PAD
18	2502432	2	BEARING, 1-1/2 BORE X 2 LG
19	5560254	5	THRUST WASHER
20	0110166	1	LINK
21	0070141	5	SLIDE PAD
22	0071341	6	SHIM, .063 THICK
23	972449	10	CAPSCREW, 3/8-16 X 3/4 LG FH SOCKET CAD PLATED
24	0070029	2	SLIDE PAD
25	0070838	2	SHIM, .030 THICK
26	0071272	2	SHIM, .063 THICK
27	5560644	10	CAPSCREW, 3/8-16 X 1-1/4 LG FH SOCKET CAD PLATING
28	5560033	10	NUT, 3/8-16 ESNA
29	0070440	1	LINK PIN
30	5065709	2	STRAIGHT THREAD ADAPTER
31	5037006	2	ELBOW, 90SWIVEL NUT
32	6010116	2	CARTRIDGE HOLDING VALVE

## Extension Cylinder Mounting



## Platform Mounting – TB80

Item	Part No.	Qty.	Description
1		1	PLATFORM – CONSULT FACTORY
2	0072552	1	PLATFORM ROTATOR
3		1	PLATFORM GATE – SEE PAGE 67
4	0070441	1	PIN, SLAVE LEVEL CYLINDER TO PLATFORM
5	0070446	1	PIN, PLATFORM TO TIP BOOM
6	0070033	1	PIN LOCK
7	0070132	1	PIN LOCK
8	987109	4	WASHER 5/16 MED LOCK
9	0070473	4	CAPSCREW 5/16-18 DRILLED HEAD
10	9980012	1	.040 DIA SS SAFETY LOCKWIRE – SOLD IN ONE POUND CAN
11	5560039	4	NUT 1/2-13 SELF LOCKING
12	986359	8	WASHER 1/2 MED LOCK
13	971009	2	CAPSCREW 1/2-13 X 4 HH GR5
14	970909	2	CAPSCREW 1/2-13 X 1-1/2 HH GR5
15	0070874	1	COVER, PLATFORM ROTATOR
16	0070351	1	BEARING SPACER
17	2502832	2	BEARING

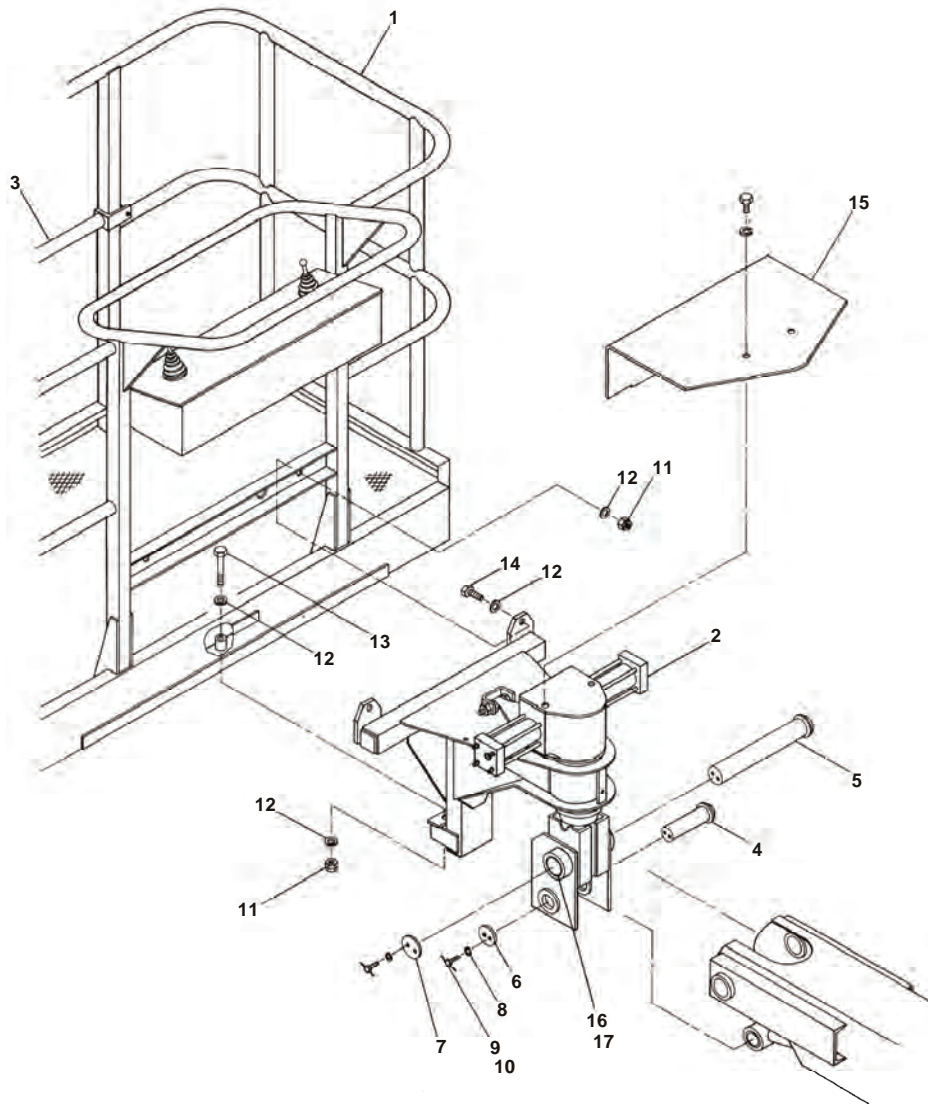

AW0074353

## Platform Mounting – TB80



# Platform Gate

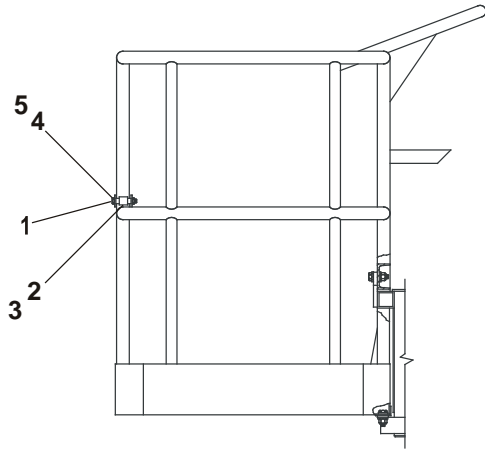

Gravity gate, steel platform

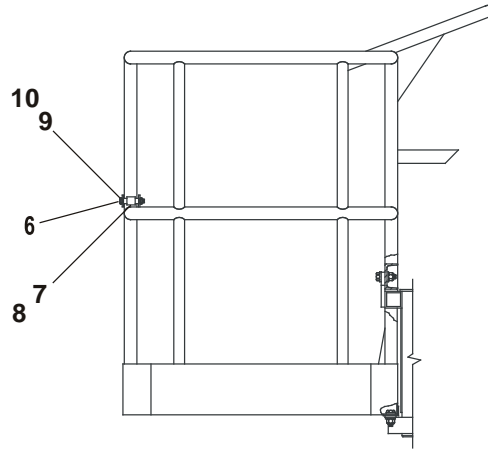

Gravity gate, aluminum platform

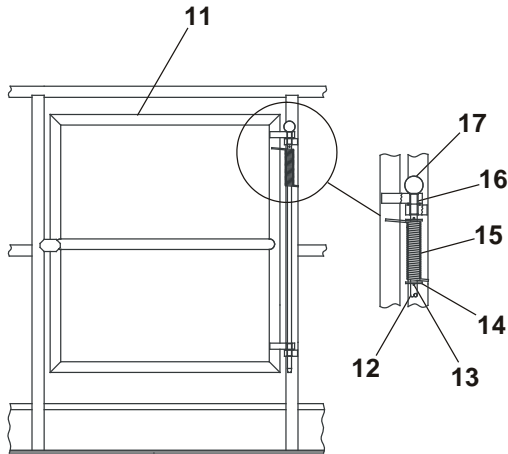

Swinging gate, steel platform

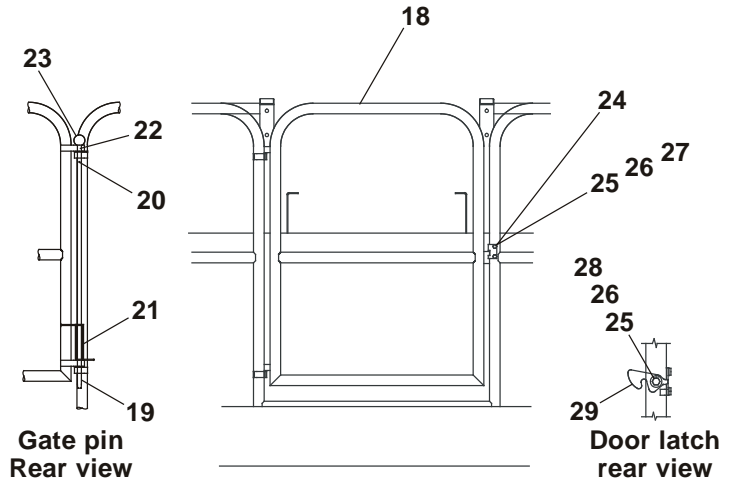

Swinging gate, aluminum platform

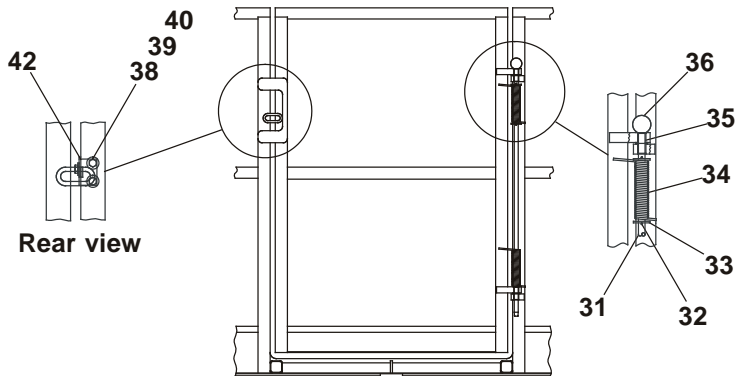

Full height swinging gate, steel platform

# Platform Gate

AWM00207

## Platform Gate

Item	Part No.	Qty.	Description
1	0071951	1	GRAVITY GATE FOR 5 FT AND 8 FT STEEL PLATFORMS
2	0150509	2	GRAVITY GATE, STEEL PLATFORM
3	0071953	2	ROLLER, STEEL GRAVITY GATE
4	970529	2	ROLLER SPACER, STEEL GRAVITY GATE
5	5560033	2	CAPSCREW 3/8-16 X 2-1/2 INCH LONG HEX HEAD GRADE 5
			NUT 3/8-16 SELF LOCKING
			GRAVITY GATE FOR 5 FT AND 8 FT ALUMINUM PLATFORMS
6	016117728	1	GRAVITY GATE SERVICE KIT - (KIT INCLUDES ITEMS 6 THROUGH 10)
7	0161177	1	GRAVITY GATE, ALUMINUM PLATFORM
8	0161182	2	ROLLER, ALUMINUM GRAVITY GATE
9	0161184	2	ROLLER SPACER, ALUMINUM GRAVITY GATE
10	970889	2	CAPSCREW 1/2-13 X 1 INCH LONG HEX HEAD GRADE 5
	5560039	2	NUT 1/2-13 SELF LOCKING
			SWINGING GATE FOR 5 FT AND 8 FT STEEL PLATFORMS
11	0071834	1	SWINGING GATE, STEEL PLATFORM
12	0322724	1	PIN, GATE HINGE
13	988179	2	COTTER PIN 1/8 INCH DIAMETER X 1 INCH LONG
14	986359	2	WASHER 1/2 MEDIUM FLAT
15	0071837	1	SPRING, TORSION
16	2570002	2	BEARING
17	2667500	1	KNOB, GATE HINGE PIN
			SWINGING GATE FOR 5 FT AND 8 FT ALUMINUM PLATFORMS
18	0160970	1	SWINGING GATE, ALUMINUM PLATFORM
19	0322724	1	PIN, GATE HINGE
20	5560056	1	ROLL PIN 1/8 INCH DIAMETER X 1 INCH LONG
21	0071837	1	SPRING, TORSION
22	2570002	2	BEARING
23	2667500	1	KNOB, GATE HINGE PIN
24	0161472	1	LATCH STOP
25	970099	3	CAPSCREW 1/4-20 X 5/8 INCH LONG HEX HEAD GRADE 5
26	984529	3	NUT SERT 1/4-20
27	987099	2	WASHER 1/4 MEDIUM LOCK
28	986019	1	WASHER 1/4 MEDIUM FLAT
29	300891	1	DOOR LATCH
			FULL HEIGHT SWINGING GATE FOR 8 FT STEEL PLATFORMS
30	0074468	1	FULL HEIGHT SWINGING GATE, STEEL PLATFORM
31	0322724	1	PIN, GATE HINGE
32	988179	2	COTTER PIN 1/8 INCH DIAMETER X 1 INCH LONG
33	986359	2	WASHER 1/2 MEDIUM FLAT
34	0071837	1	SPRING, TORSION
35	2570002	2	BEARING
36	2667500	1	KNOB, GATE HINGE PIN
37	300891	1	DOOR LATCH
38	984529	3	NUT SERT 1/4-20
39	970099	3	CAPSCREW 1/4-20 X 5/8 INCH LONG HEX HEAD GRADE 5
40	987099	2	WASHER 1/4 MEDIUM LOCK
41	986019	1	WASHER 1/4 MEDIUM FLAT
42	0181574	1	LATCH STOP

## Platform Gate



## Platform Rotator – TB80

Item	Part No.	Qty.	Description
1	0072553	1	PYLON, PLATFORM ROTATOR
2	0070916	1	KEY
3	0072555	1	COLLAR
4	0072561	1	THRUST BEARING
5	2504856	2	BEARING
6	0072562	1	BEARING SPACER
7	0072556	1	MOUNTING FRAME, PLATFORM ROTATOR
8	970919	2	CAPSCREW 1/2-13 X 1-3/4 INCH LONG HEX HEAD GRADE 5
9	970849	6	CAPSCREW 1/2-13 X 1-1/4 INCH LONG HEX HEAD GRADE 5
10	987139	6	WASHER 1/2 MEDIUM LOCK
11	0072818	1	TORQUE PLATE, PLATFORM ROTATOR
12	0073783	1	VALVE SPACER
13	6010628	1	DUAL HOLDING VALVE, PLATFORM ROTATION
14	986269	2	WASHER 5/16 MEDIUM FLAT
15	987109	4	WASHER 5/16 MEDIUM LOCK
16	970349	2	CAPSCREW 5/16-18 X 2-3/4 INCH LONG HEX HEAD GRADE 5
17	7110348	1	O-RING
18	011077128	1	PLATFORM ROTATOR
19	0070132	1	PIN LOCK
20	0070473	2	CAPSCREW 5/16-18 DRILLED HEAD
21	9980012	1	.040 INCH DIA SS SAFETY LOCKWIRE - (SOLD IN ONE POUND CAN)
22	0072508	1	COVER PLATE, PLATFORM ROTATOR
23	7110348	1	O-RING
24	984409	2	NUT 1/2-13 HEX JAM

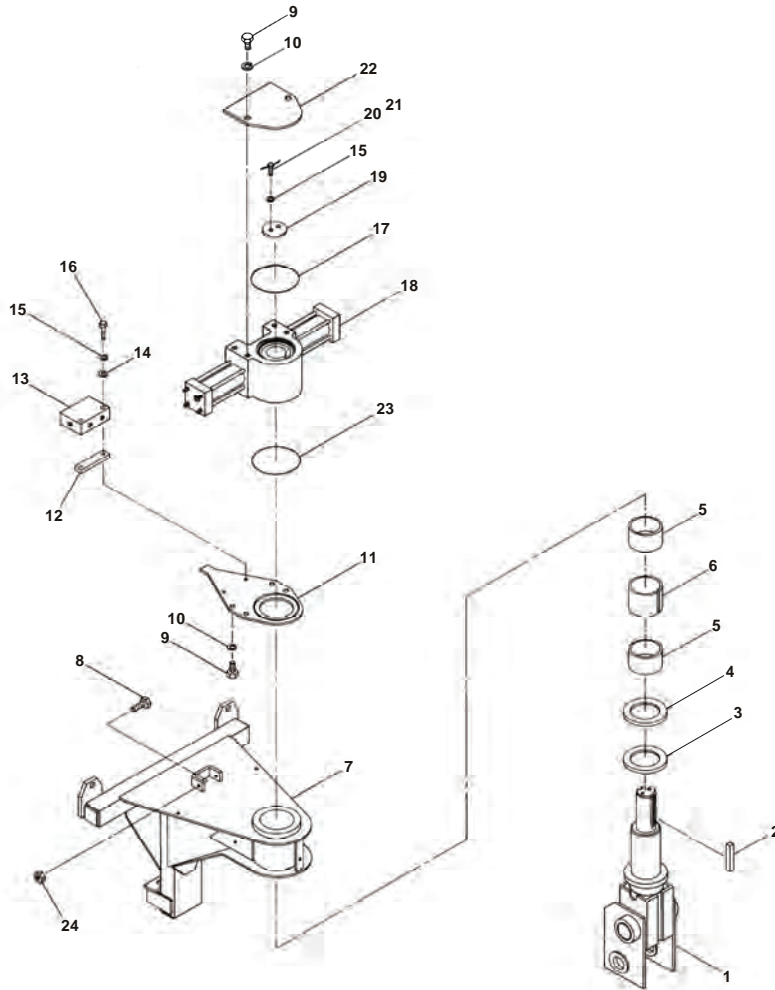

## Platform Rotator – TB80

AW0072552



F

E

D

C

B

A

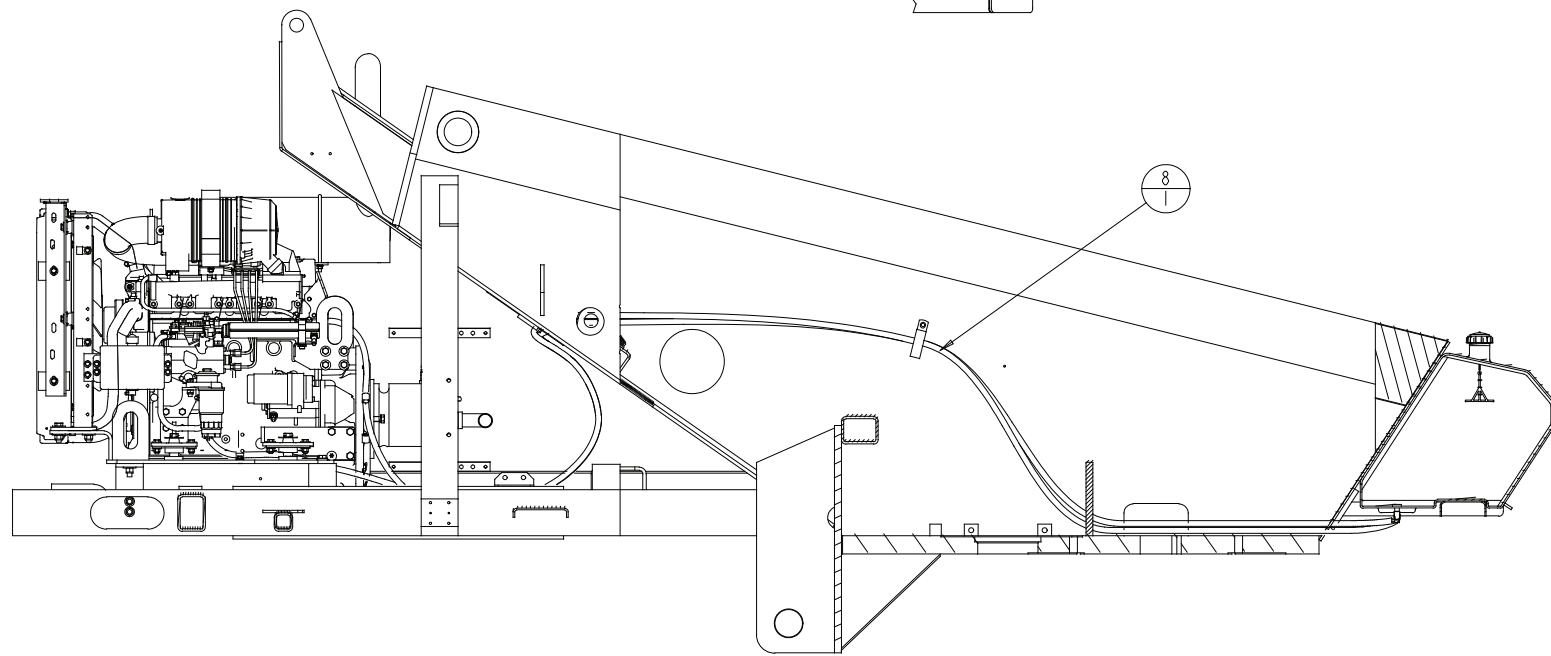

FUEL LINE ROUTING DETAIL

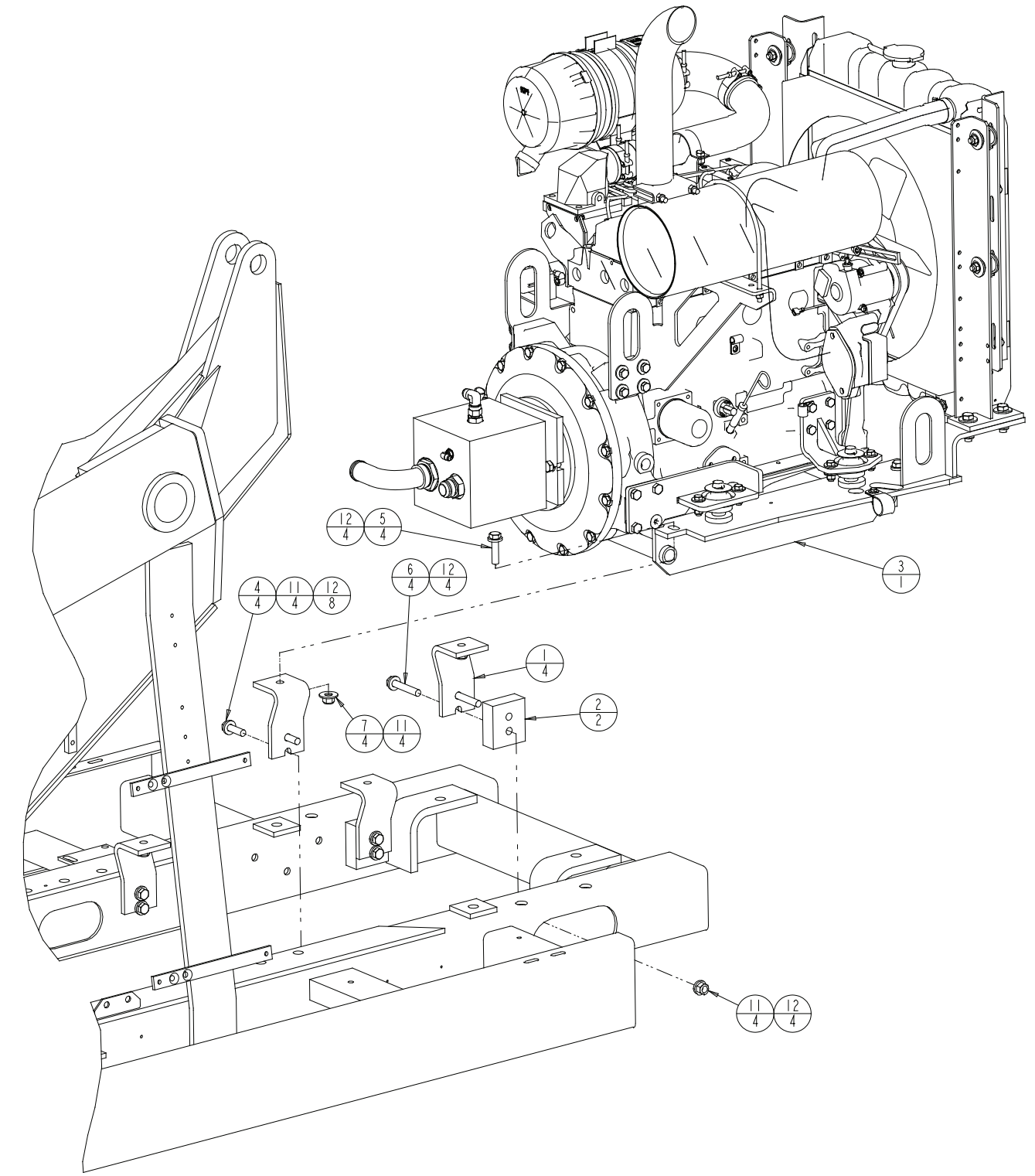
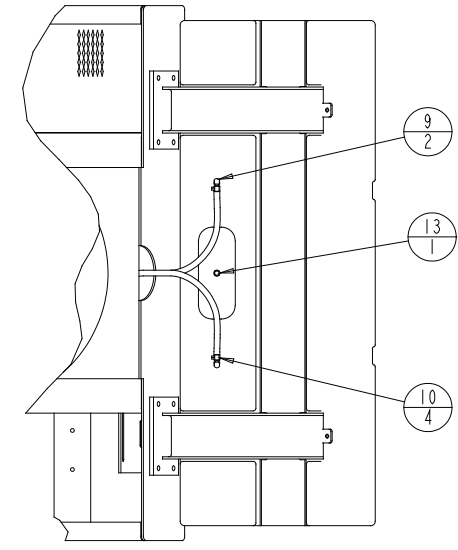

0112403

Engine Mounting  
Cummins 3.3

Repair Parts - 71

1 2 3 4 5 6 7 8 9

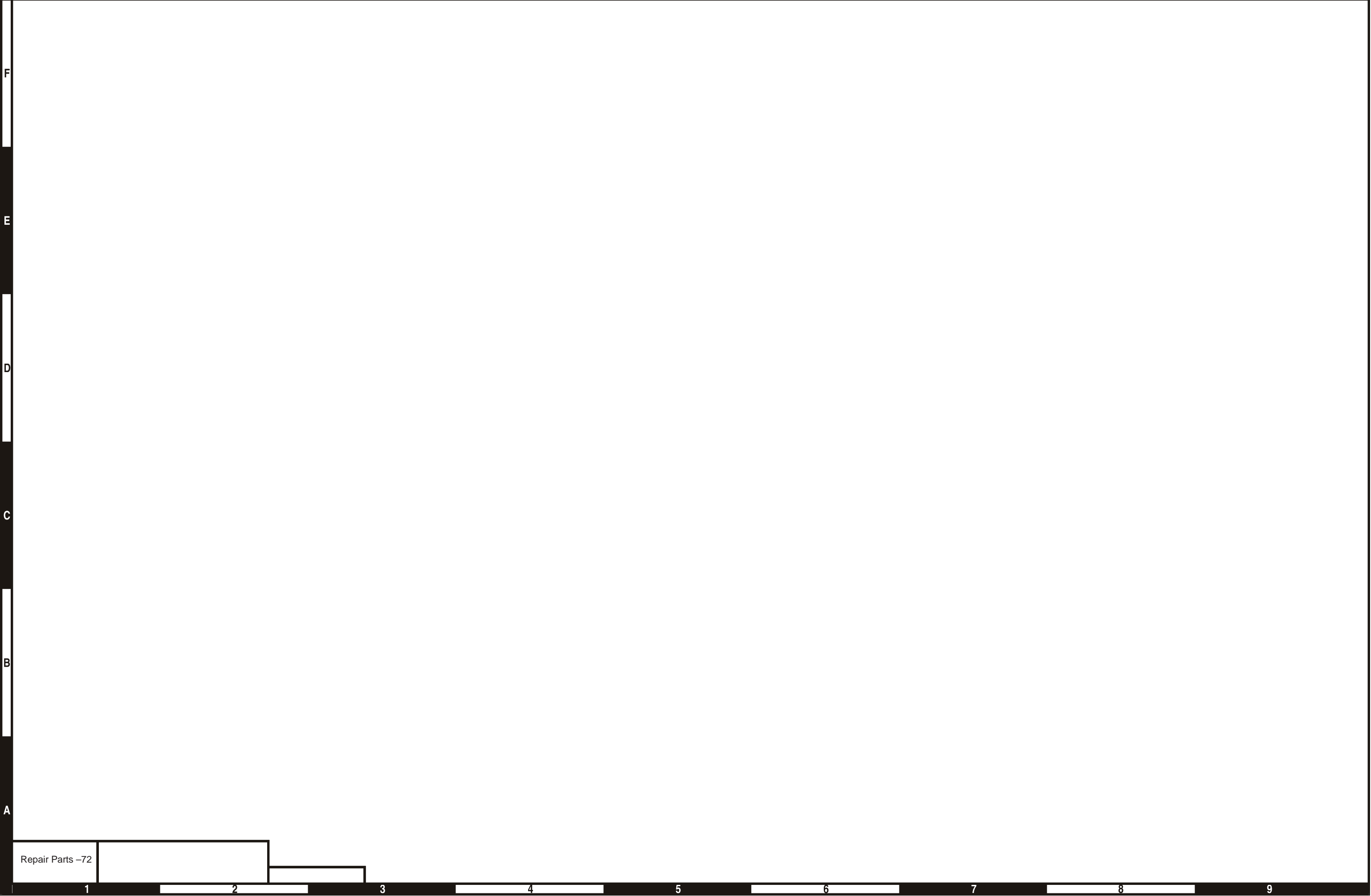

F

E

D

C

B

A

Repair Parts -72

1

2

3

4

5

6

7

8

9

## Engine Mounting – Cummins 3.3

Item	Part No.	Qty.	Description
1	0083438	4	ENGINE MOUNT CUMMINGS
2	0112241	2	SPACER
3	0112381	1	ENGINE ASSEMBLY WITH RADIATOR
4	910919	4	BOLT .500-13 1.75 GR5
5	970929	4	BOLT .500-13 2.00 GR5
6	970969	4	BOLT .500-13 3.00
7	986359	4	WASHER FLAT .500
8	5010005	33 FT	HOSE .38 831-6 PUSH LOCK
9	5093038	2	FTG ELB90 MALE -6N-6H BR
10	5550006	4	CLAMP WORM DRV #6
11	5560039	12	NUT LKG .500-13
12	5560168	20	WASHER HARD FLAT .500 SP
13	7714203	1	PIPE PLUG 3/8 NPT SQ HD BLK

## Engine Mounting – Cummins 3.3



F

E

D

C

B

A

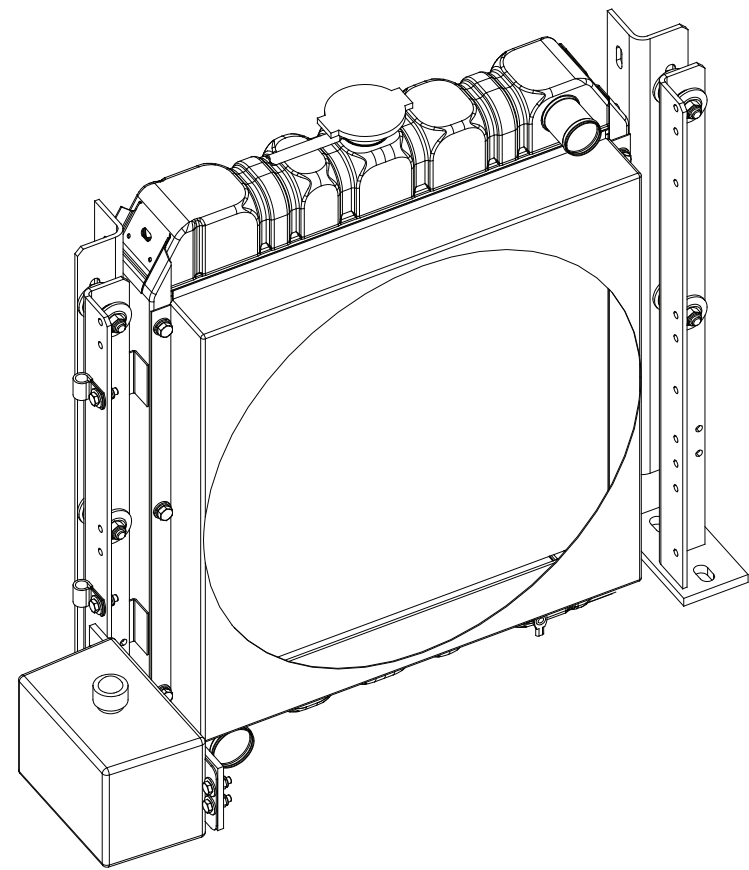

REFERENCE VIEW  
SCALE 0.31

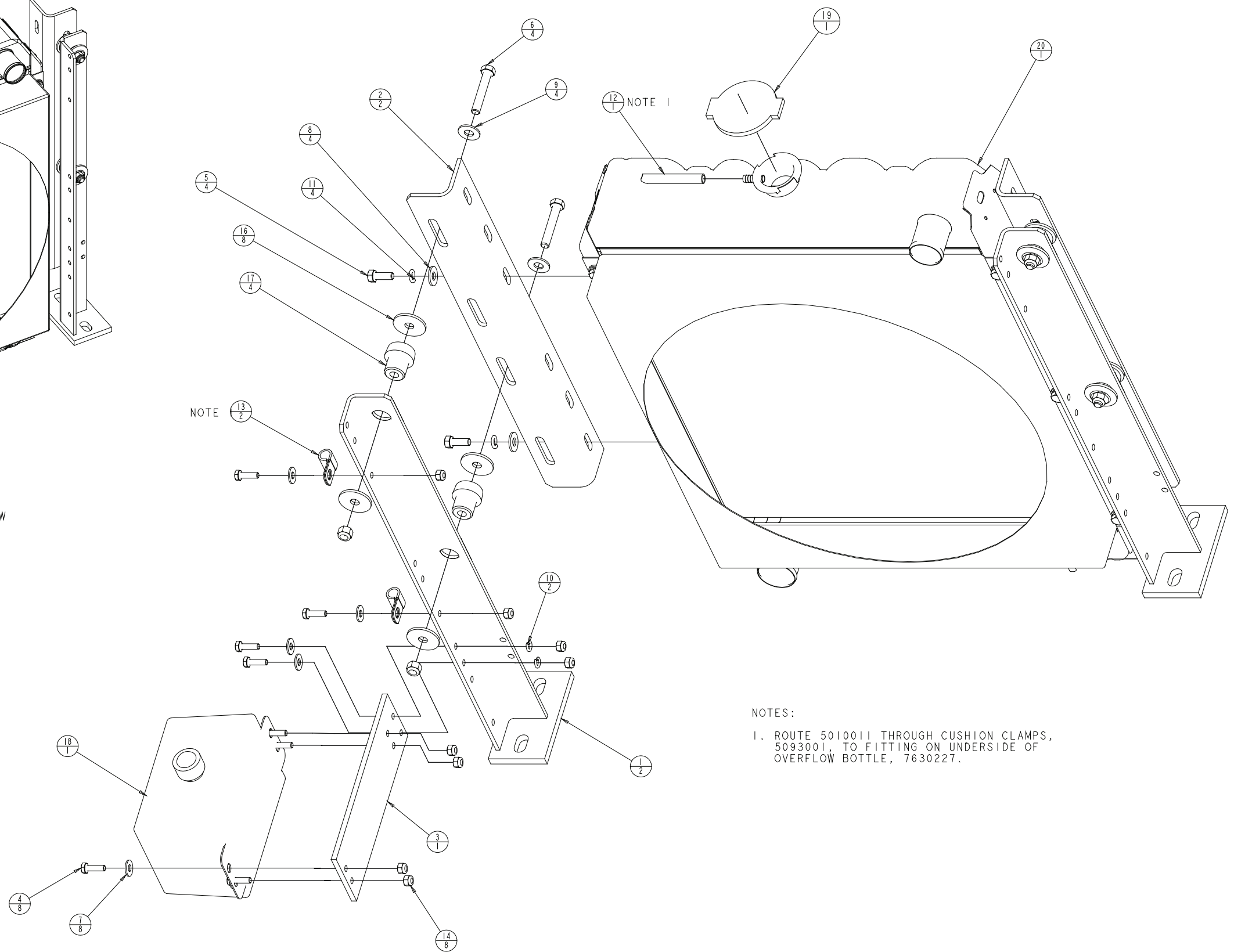

NOTES:

1. ROUTE 5010011 THROUGH CUSHION CLAMPS, 5093001, TO FITTING ON UNDERSIDE OF OVERFLOW BOTTLE, 7630227.

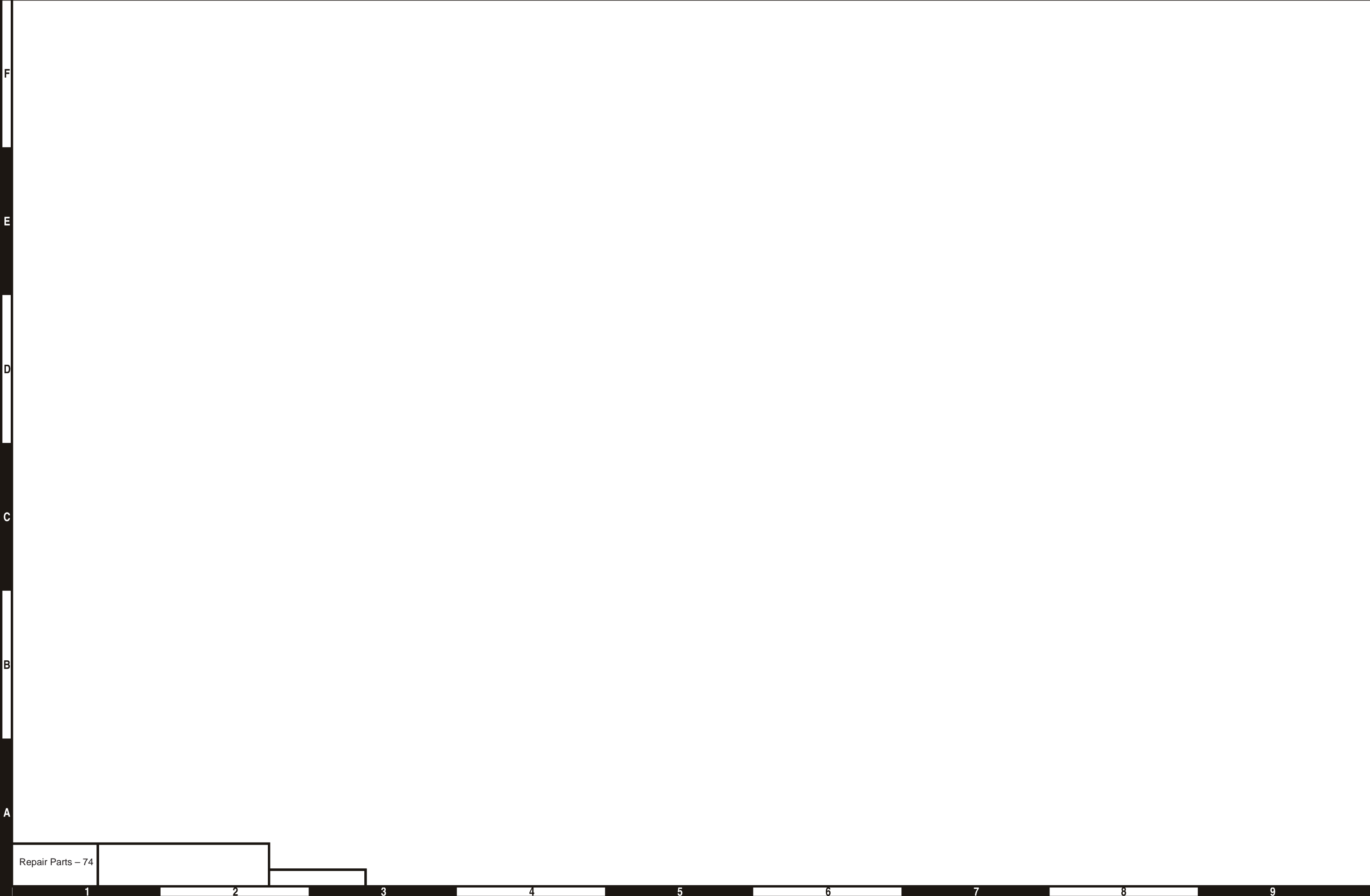

F

E

D

C

B

A

Repair Parts - 74

1

2

3

4

5

6

7

8

9



## Radiator – Cummins 3.3

Item	Part No.	Qty.	Description
1	0074630	2	WLDMT RAD BRKT
2	0083153	2	ANGLE RADIATOR MOUNT
3	0180832	1	MTG PLATE OVFL BOTTLE
4	970039	8	BOLT .25-20 .875 GR5
5	970249	4	BOLT .313-18 .875
6	970519	4	BOLT .375-16 2.25 GR5
7	986019	8	WASHER FLAT .250
8	986269	4	WASHER FLAT .313
9	986299	4	WASHER FLAT .38
10	987099	2	WASHER LOCK .250
11	987109	4	WASHER LOCK .313
12	5010011	4 FT	HOSE SAE30R2-05 .312 FUEL
13	5093001	2	CUSHION CLAMP #8 (1/2)
14	5560004	8	NUT LKG .250-20
15	5560033	4	NUT LKG .375-16
16	5560179	8	WASHER SPCL FLAT
17	7630180	4	RADIATOR CAP 13 PSI
18	7630227	1	BOTTLE 2 QT OVERFLOW
	8060277	1	CAP
19	7630239	1	RADIATOR CAP 13 PSI
20	7630756	1	RADIATOR ASSEMBLY

## Radiator – Cummins 3.3



F

E

D

C

B

A

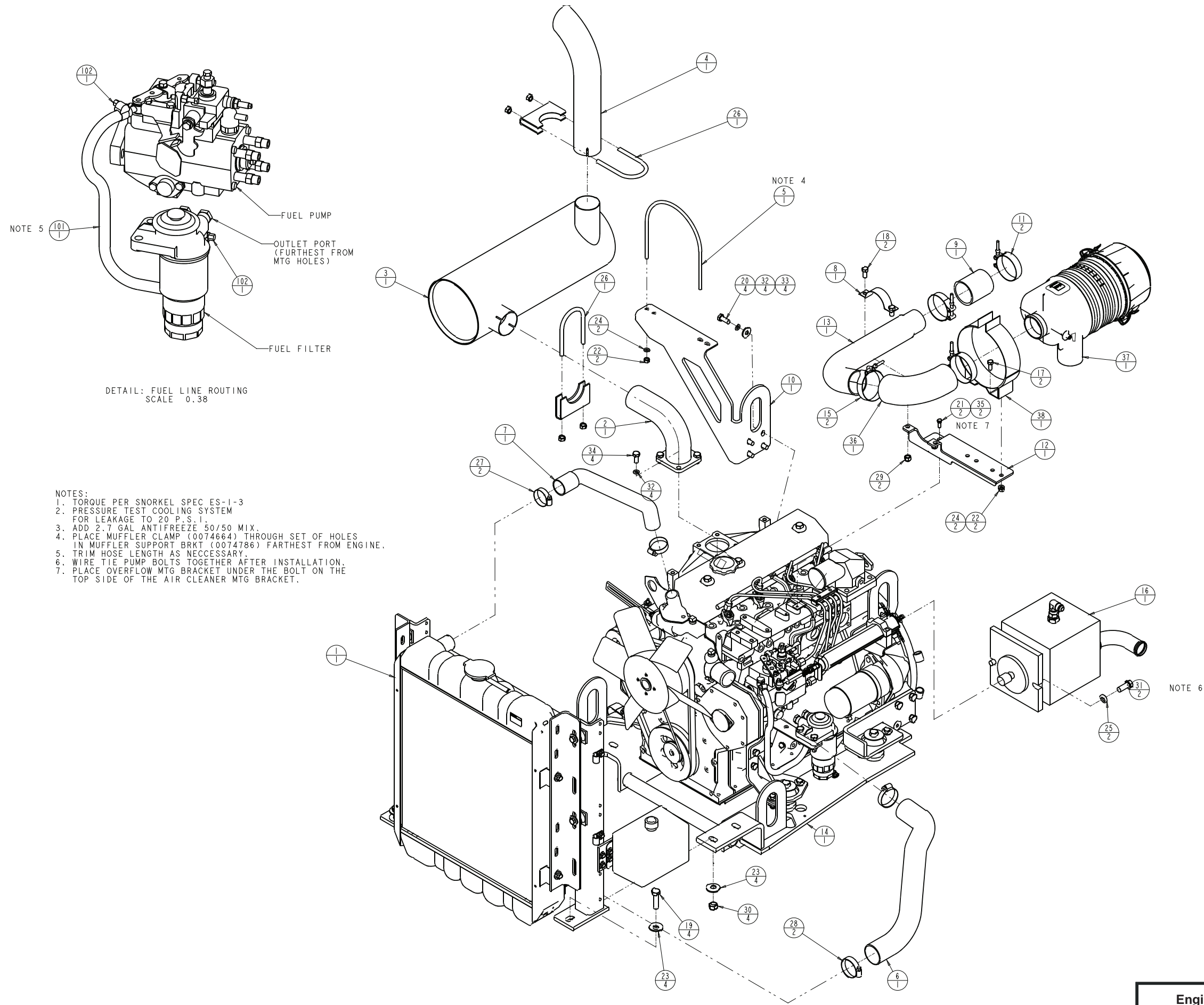

NOTE 5

101

1

102

1

102

1

102

1

102

1

102

1

102

1

102

1

102

1

102

1

102

1

102

1

102

1

102

1

102

1

102

1

102

1

102

1

102

1

102

1

102

1

102

1

DETAIL: FUEL LINE ROUTING  
SCALE 0.38

NOTES:

1. TORQUE PER SNORKEL SPEC ES-1-3
2. PRESSURE TEST COOLING SYSTEM FOR LEAKAGE TO 20 P.S.I.
3. ADD 2.7 GAL ANTIFREEZE 50/50 MIX.
4. PLACE MUFFLER CLAMP (0074664) THROUGH SET OF HOLES IN MUFFLER SUPPORT BRKT (0074786) FARTHEST FROM ENGINE.
5. TRIM HOSE LENGTH AS NECESSARY.
6. WIRE TIE PUMP BOLTS TOGETHER AFTER INSTALLATION.
7. PLACE OVERFLOW MTG BRACKET UNDER THE BOLT ON THE TOP SIDE OF THE AIR CLEANER MTG BRACKET.

NOTE 4

5

1

NOTE 7

21

2

35

2

NOTE 6

16

1

31

2

25

2

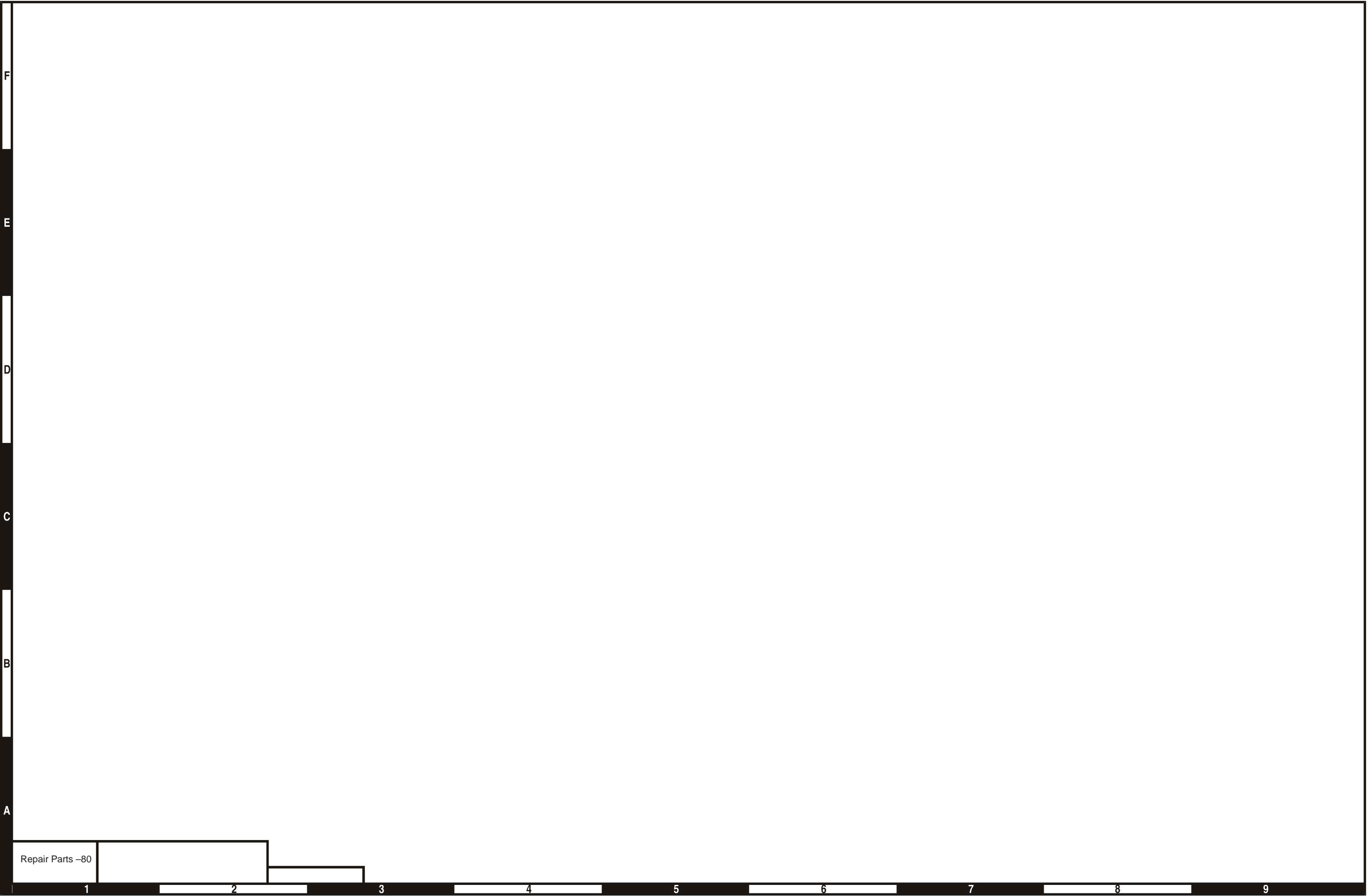

F

E

D

C

B

A

Repair Parts -80

1

2

3

4

5

6

7

8

9

## Engine with Radiator – Cummins 3.3

Item	Part No.	Qty.	Description
1	0074634	1	RADIATOR ASSEMBLY
2	0074641	1	WLDMT EXHAUST ELB LONG
3	0074644	1	MUFFLER
4	0074645	1	TAIL PIPE
5	0074664	1	MUFFLER CLAMP
6	0074684	1	HOSE LOWER RAD
7	0074685	1	HOSE UPPER RAD
8	0074687	1	CLAMP AIR INTAKE TUBE
9	0074688	1	ADAPTOR HOSE AIR INTAKE
10	0074789	1	MUFFLER SUPPORT BRACKET
11	0083165	2	CLAMP T-BOLT 2.75 NOM
12	0083167	1	MT BRKT AIR CLEANER
13	0073175	1	AIR CLEANER HOSE COUPLER 2.5-2.25
14	0083445	1	ASSY ENG TRAY
15	0083544	2	CLAMP T-BOLT 3.00 NOM
16	011157828	1	PUMP SUB ASSY
17	970239	2	BOLT .313-18 .750 GR5
18	970449	2	BOLT .375-16 .750 GR5
19	970919	4	BOLT .500-13 1.75 GR5
20	972019	4	BOLT 10MM-1.50P 25MM GR5
21	975209	2	BOLT 6MM-1.00P 18MM GR5
22	984089	4	NUT HEX .313-18
23	986359	8	WASHER FLAT .500
24	987109	4	WASHER LOCK .313
25	987109	2	WASHER LOCK .500
26	550026	2	EXHAUST CLAMP
27	5550038	2	CLAMP WORM DRV #28
28	5550040	2	CLAMP WORM DRV #40
29	5560033	2	NUT LKG .375-16
30	5560039	4	NUT LKG .500-13
31	5560136	2	BOLT .500-13 1.25 GR5 NYLOCK DRILLED
32	5560356	8	WASHER LOCK M10
33	5560364	4	WASHER FLAT M10
34	5560625	4	BOLT 10MM-1.50P 20MM
35	5560664	2	WASHER LOCK M6
36	7630015	1	90 DEGREE ELBOW
37	7630755	1	AIR CLEANER
	8140011	1	ELEMENT
	8140014	3	RETAINER CLIP – CAP
	8140012	1	DUST EJECTOR
	8140013	1	COVER
38	7630759	1	BRACKET AIR CLEANER
101	5010005	2.75 FT	HOSE .38 #831-6 PUSH LOCK
102	5550006	2	CLAMP WORM DRV #6

## Engine with Radiator – Cummins 3.3



F

E

D

C

B

A

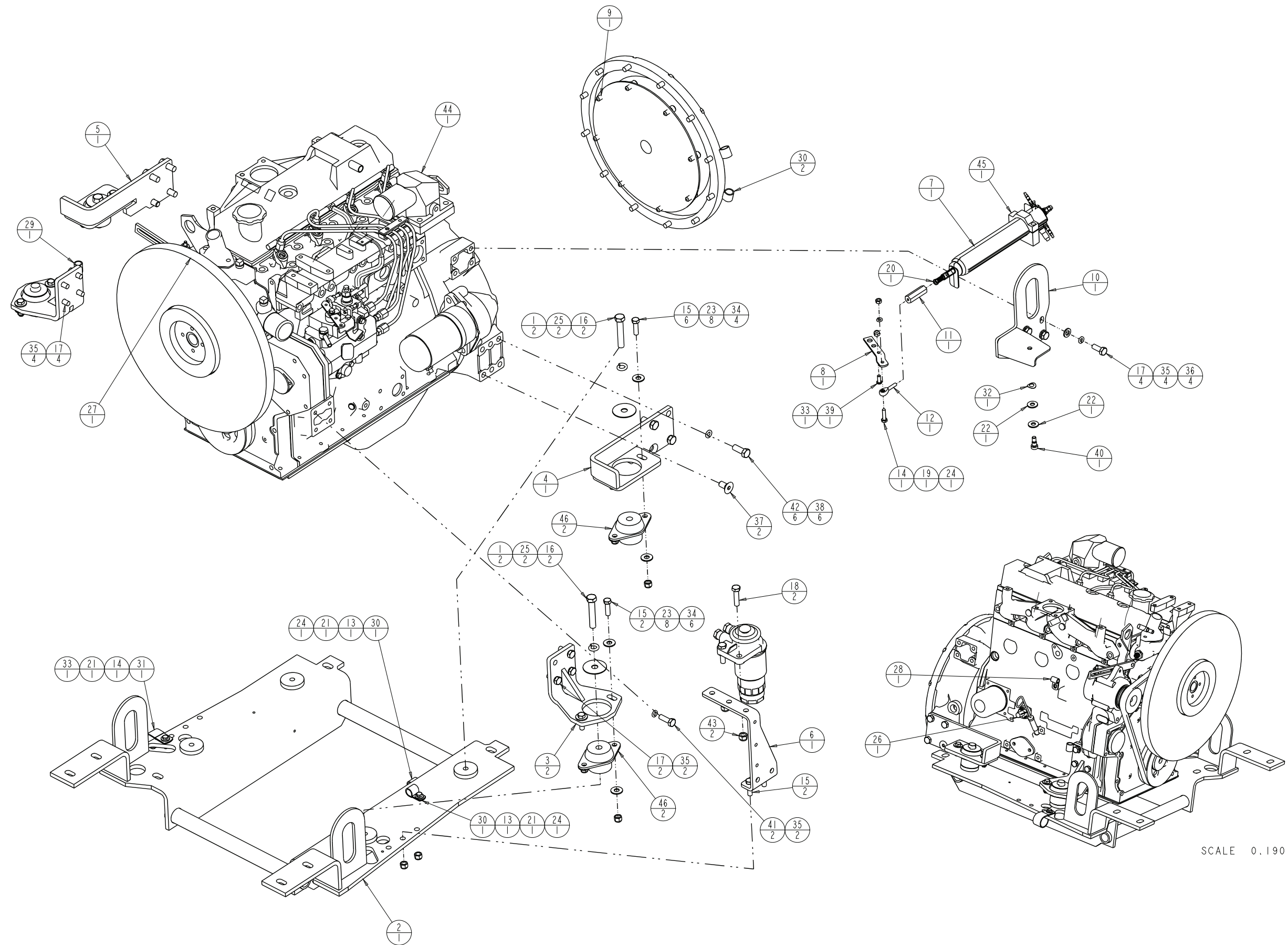

SCALE 0.190

0083445

Engine Tray - Cummins 3.3

Repair Parts - 83

1 2 3 4 5 6 7 8 9

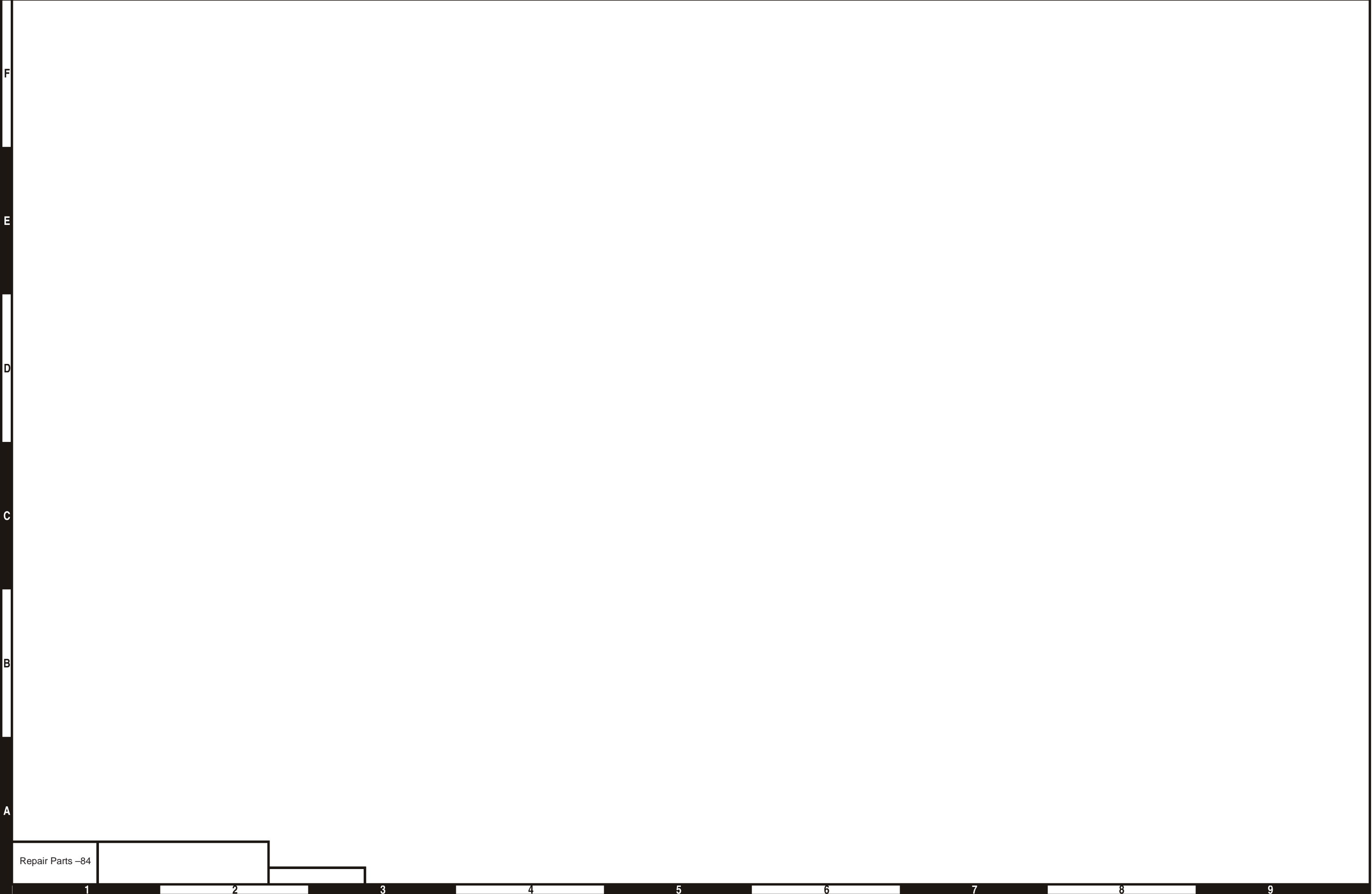

F

E

D

C

B

A

Repair Parts -84

1

2

3

4

5

6

7

8

9



## Engine Tray – Cummins 3.3

Item	Part No.	Qty.	Description
1	0070148	4	WASHER SPCL .531 X 2 X .06
2	0074615	1	WLDMT ENGINE TRAY
3	0074622	2	WLDMT FRONT BRKT
4	0074625	1	WLDMT LEFT REAR BRKT
5	0074628	1	WLDMT RIGHT REAR BRKT
6	0074972	1	BRKT, FUEL FILTER
	7630771	1	FUEL FILTER
7	007204528	1	ACTUATOR, SUB ASSY
8	0083155	1	THROTTLE LEVER EXTENSION
9	0083437	1	KIT CPLG/FLYWHEEL
10	0083570	1	THROTTLE ACTUATOR MT BRKT WLDMT
11	0083586	1	THROTTLE ACTUATOR COUPLER
12	0083587	1	ROD END
13	970019	2	BOLT .25-20 .625
14	970049	2	BOLT .25-20 1.00 GR5
15	970419	10	BOLT .375-16 1.25 GR5
16	971069	4	BOLT .500-13 2.75 GR5
17	972019	10	BOLT 10MM-1.50P 25MM GR5
18	972049	2	BOLT 10MM-1.50P 40MM GR8
19	984069	1	NUT HEX .250-20
20	984329	1	NUT JAM .250-20
21	986019	3	WASHER FLAT .250
22	984269	2	WASHER FLAT .313
23	984299	16	WASHER FLAT .38
24	987099	3	WASHER LOCK .250
25	987139	4	WASHER LOCK .500
26	3020095	1	SWITCH PRESSURE 6 PSI 1/8-27NPT
27	3070037	1	TEMP SENSOR 1/2 NPT HIGH
28	5093000	1	CUSHION CLAMP #7 (7/16)
29	5093002	1	CUSHION CLAMP #9 (9/16)
30	5093021	4	CUSHION CLAMP #8 (5/8)
31	5093024	1	CUSHION CLAMP #20 (1-1/4)
32	5530017	1	WASHER SPR CRV .375
33	5560004	2	NUT LKG .250-20
34	5560033	10	NUT LKG .375-16
35	5560356	12	WASHER LOCK M10
36	5560364	4	WASHER FLAT M10
37	5560598	2	BOLT FLSKTHD M12 25.0
38	5560614	6	WASHER LOCK M12
39	5560615	1	BOLT BTNHD .25-20 .625
40	5560618	1	BOLT SHLDR .375 .375
41	5560626	2	BOLT 10MM-1.50P 30MM
42	5560631	6	BOLT 12MM-1.75P 30MM
43	5560719	2	NUT LKG M10-1.50
44	7624766	1	ENGINE CUMMINS 3.3 (65 HP) T3
	7630770	1	OIL FILTER
45	7630323	1	ACTUATOR CLAMP
46	7630707	4	ENGINE ISOLATOR

## Engine Tray – Cummins 3.3



F

E

D

C

B

A

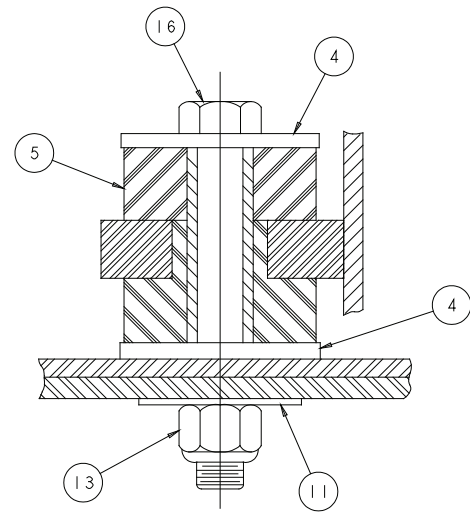

DETAIL "A"  
TYP INSTALLATION 4 PLACES

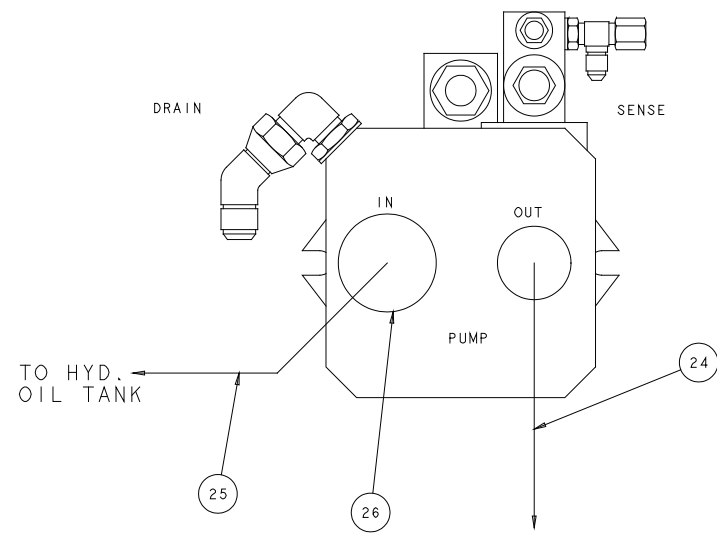

VIEW B-B

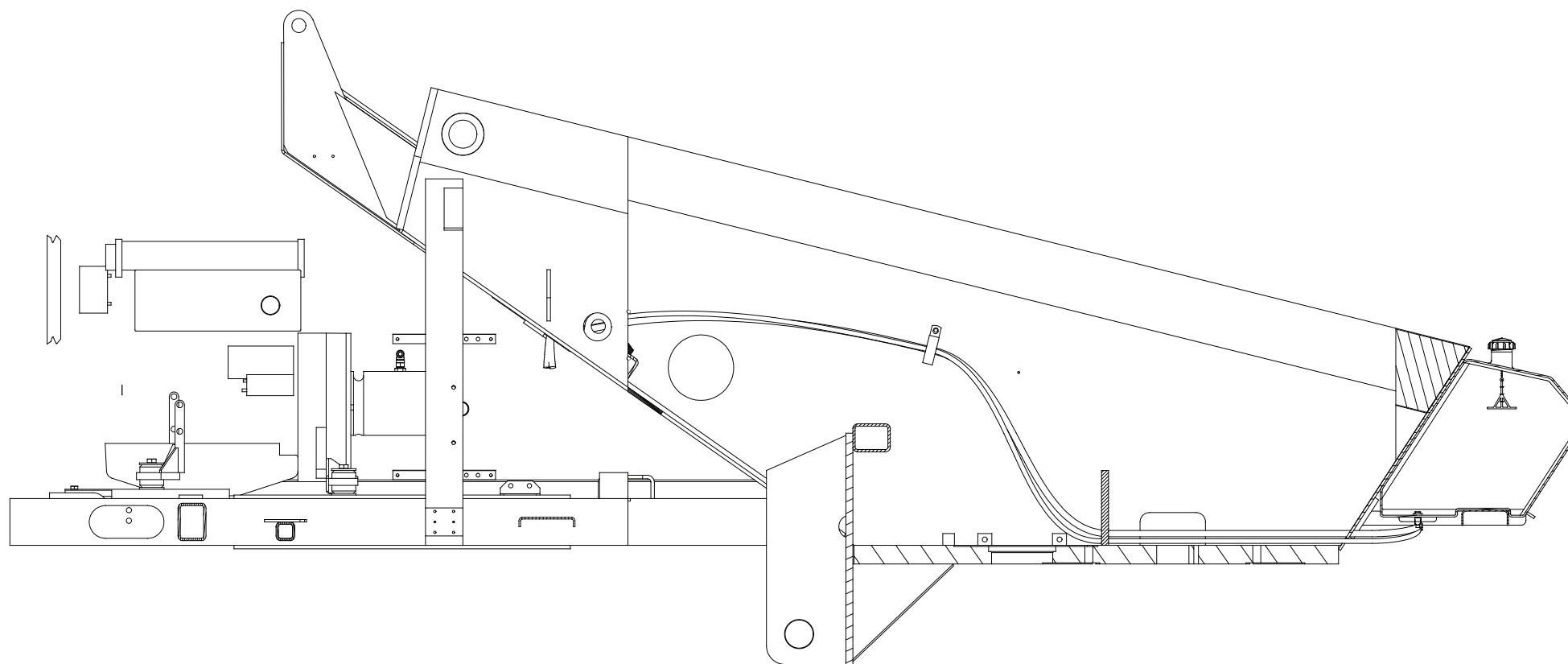
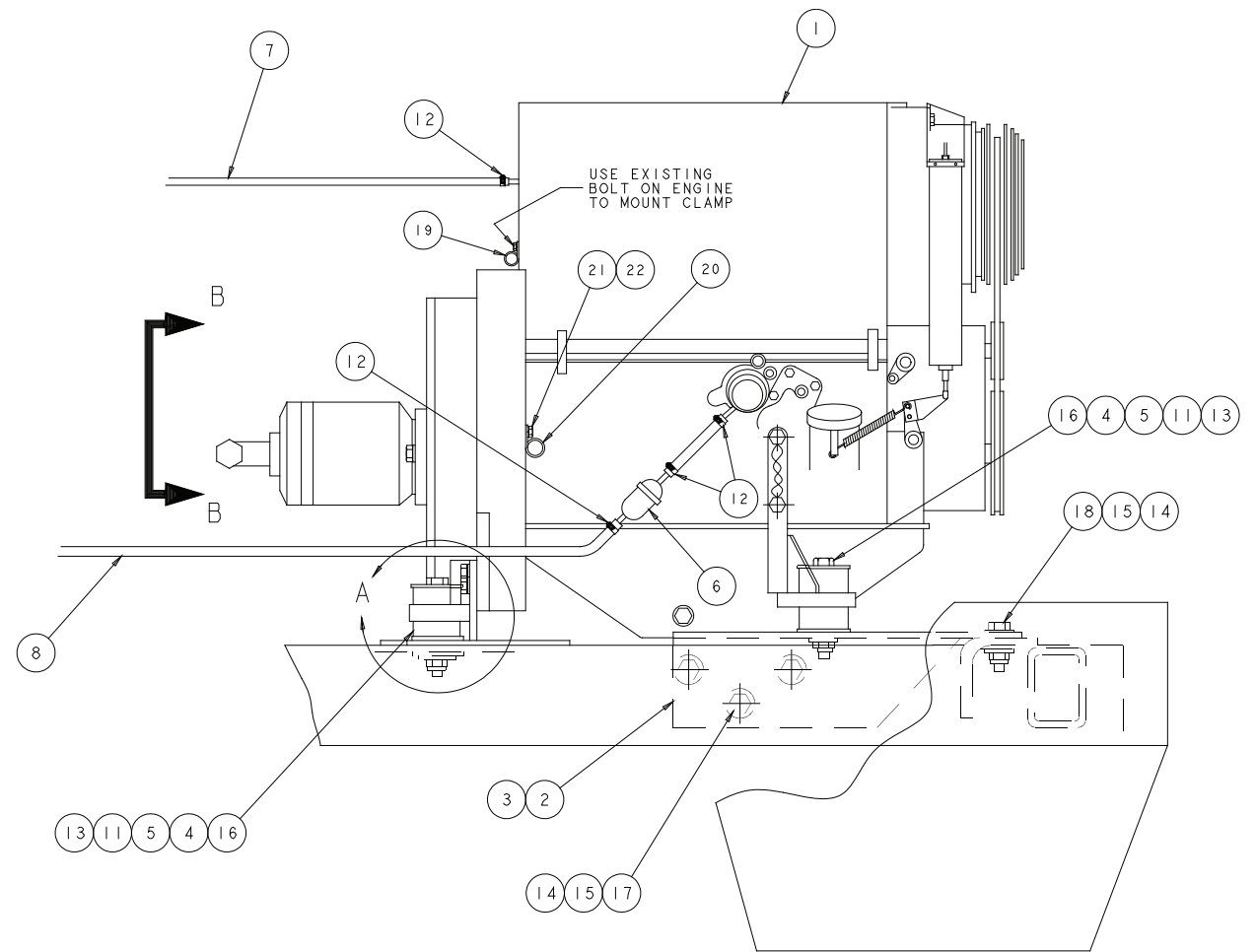

FUEL LINE ROUTING DETAIL

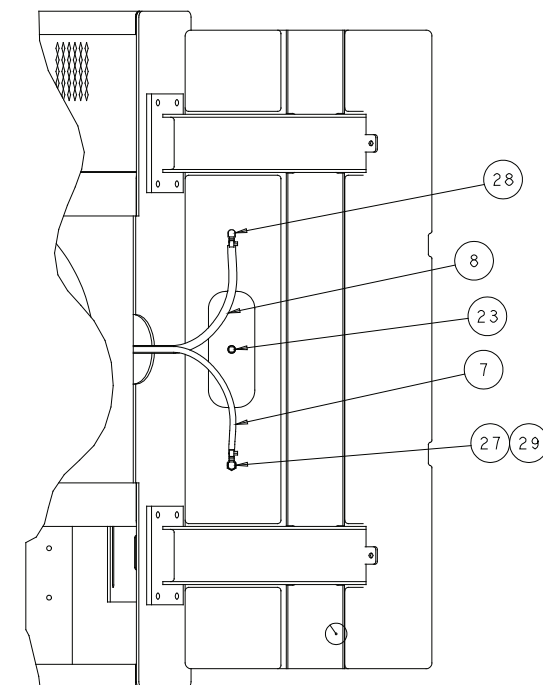

0112401

Engine Mounting  
Deutz

Repair Parts - 87

1

2

3

4

5

6

7

8

9

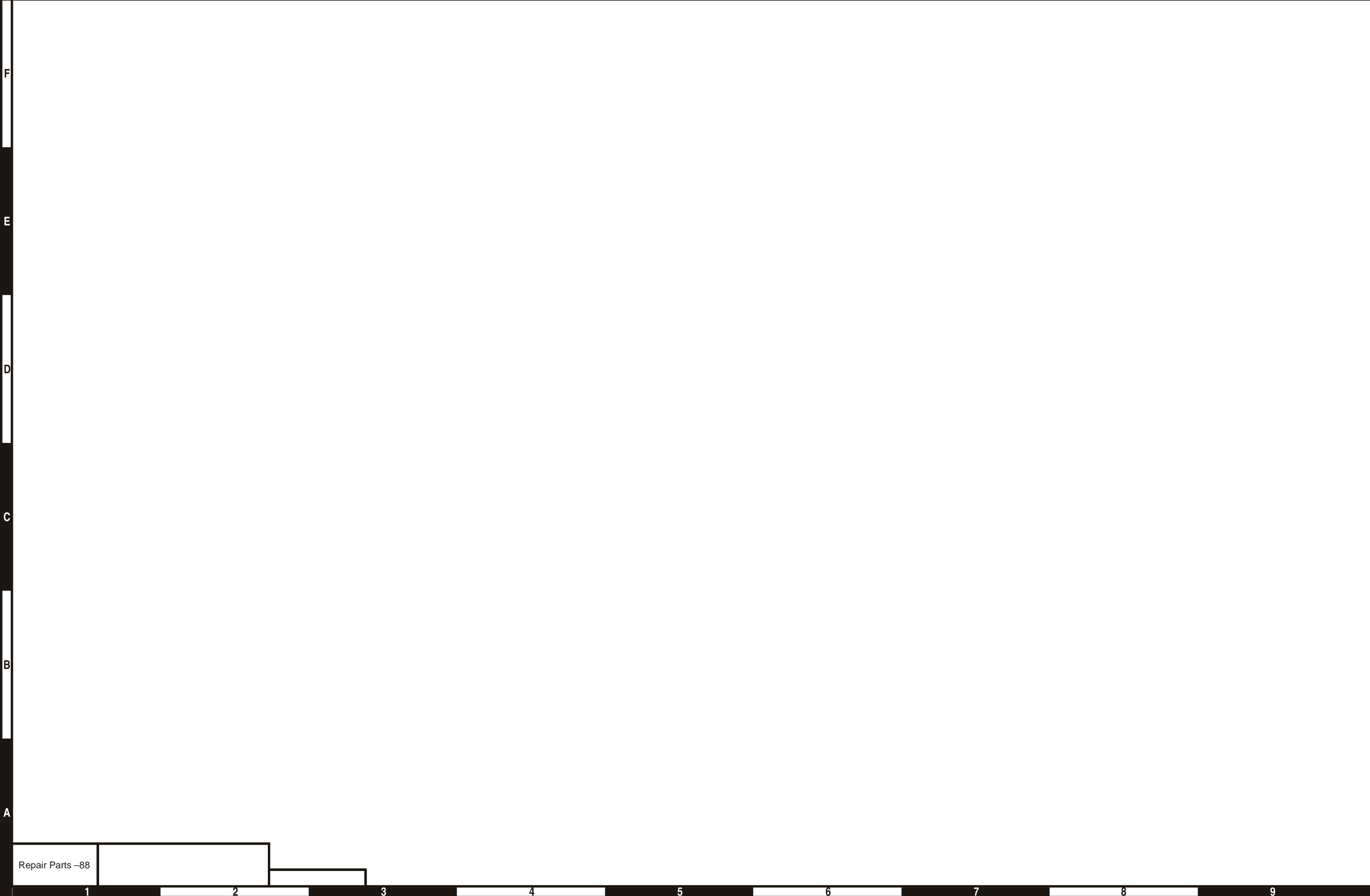

F

E

D

C

B

A

Repair Parts -88

1

2

3

4

5

6

7

8

9

## Engine Mounting – Deutz

Item	Part No.	Qty.	Description
1	0111953	1	ENGINE SUB ASSY DEUTZ
2	0111750	1	MOUNTING BRKT FRONT RH
3	0111751	1	MOUNTING BRKT FRONT LH
4	0071599	8	WASHER ENGINE MOUNTING DSL
5	7630130	4	MOUNT, ENGINE
6	7630286		FILTER IN-LINE FUEL (SUPPLIED WITH ENGINE)
7	967299	15 FT	HOSE, SAE30R2-04 TYPE 3 1/4 ID
8	5010011	15 FT	HOSE, SAE30R2-05 .312 FUEL
10	5090032	1	CLIP CUSHION .562
11	5560169	4	WASHER HARD FLAT .625 SP
12	5550028	5	CLIP WORM DRV SAE #4 TYPE M
13	5560131	4	NUT .625-11 HIGH STRENGTH
14	5560168	16	WASHER HARD FLAT .500 SP
15	5560039	8	NUT LKG .500-13
16	5560639	4	BOLT HEXHD .625-11 4.50 GR5
17	970909	6	BOLT HEXHD .500-13 1.50 GR5
18	970929	2	BOLT HEXHD .500-13 2.00 GR5
19	5093000	2	CLIP CUSHION .437
20	5093006	1	CLIP CUSHION .937
21	5560638	1	BOLT HEXHD M8 16MM GR8
22	5560355	1	WASHER LOCK M8
23	7714203	1	PIPE PLUG, 3/8 NPT SQ HD BLK
24	0110199	1	HOSE-16-16S-16S 34
25	0111821	1	HOSE SUCTION 1.50 ID 26
26	5058824	1	HOSE CLAMP
27	5076407	1	FTG BSHG RDCR -N-4N STL
28	5093039	1	FTG ELB90 MALE -6N-5H BR
29	5093040	1	FTG ELB90 MALE -4N-4H BR

## Engine Mounting – Deutz



F

E

D

C

B

A

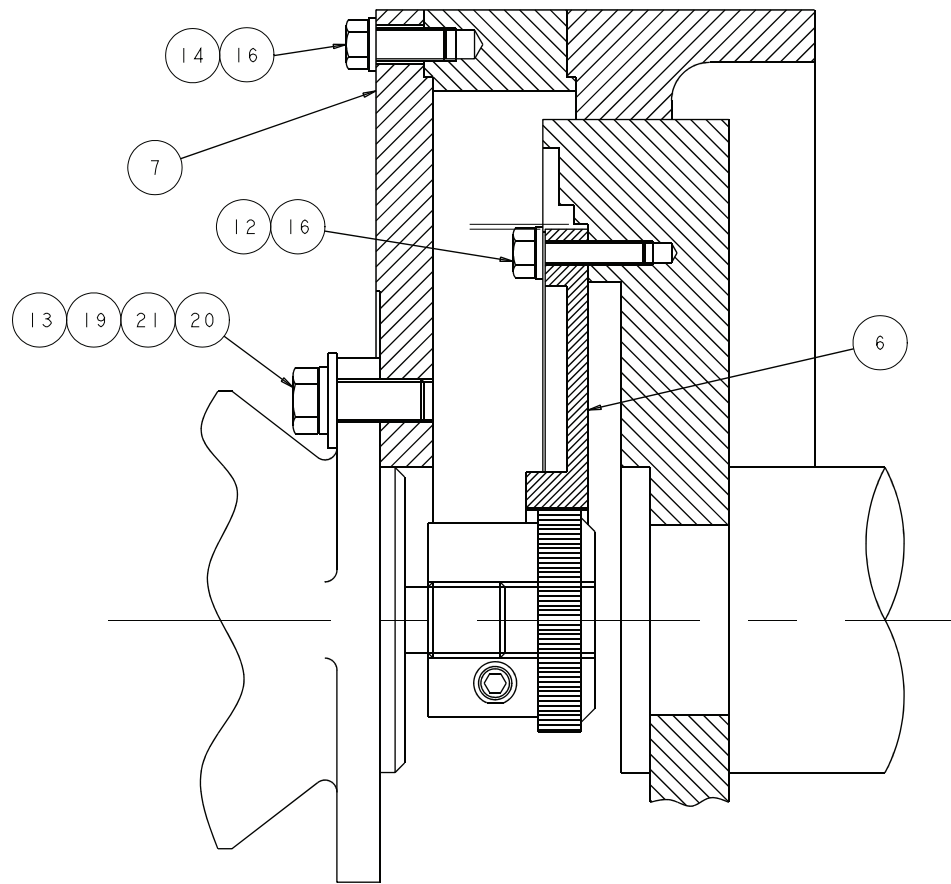
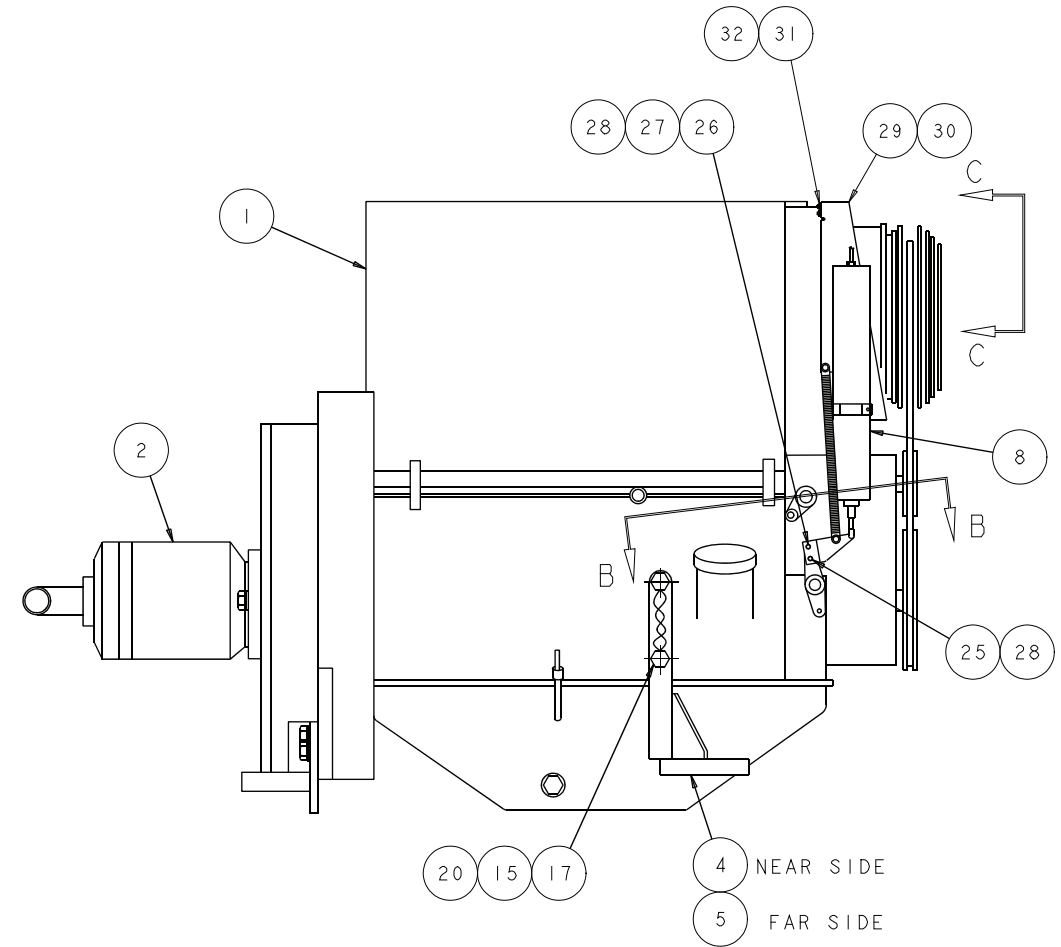
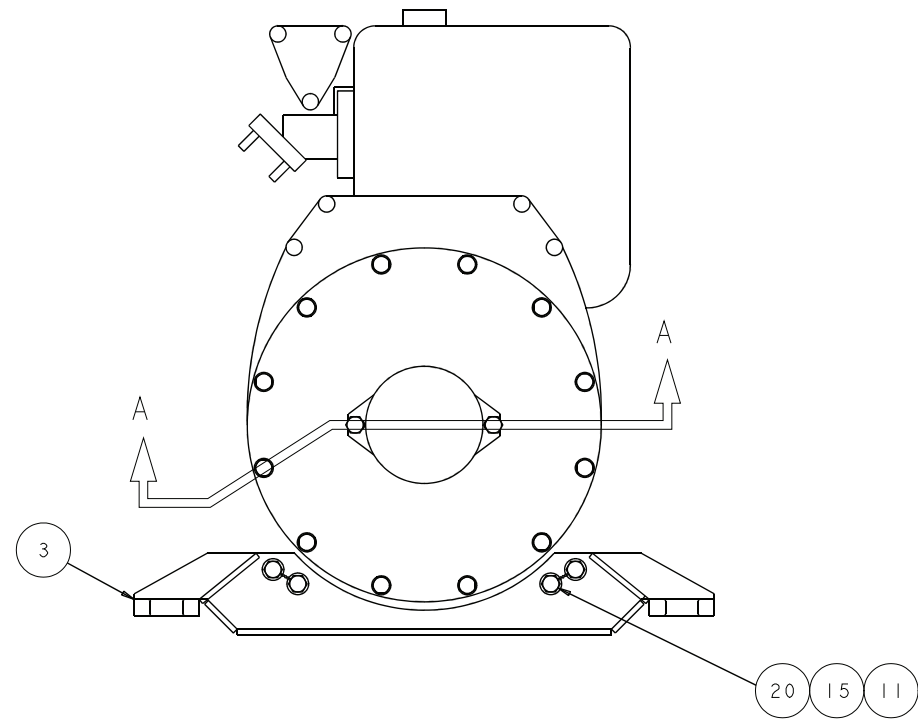

SECTION A-A

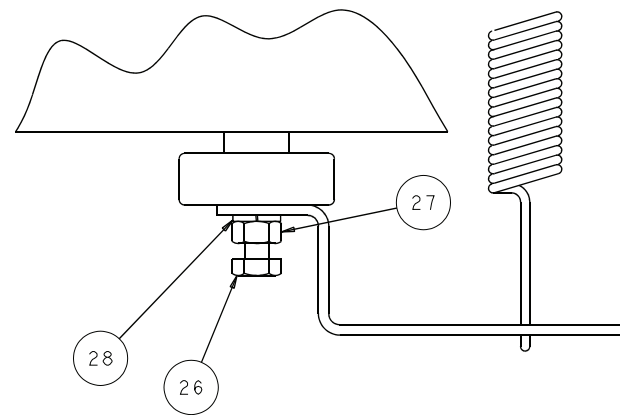

VIEW B-B

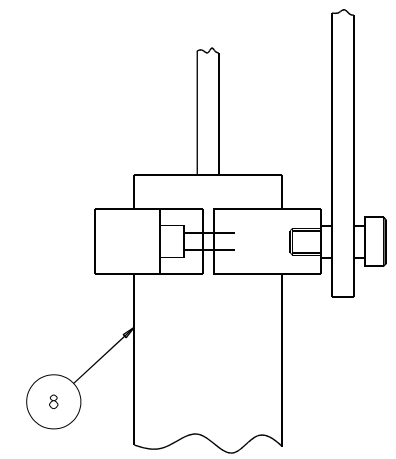

VIEW C-C



F

E

D

C

B

A

Repair Parts - 92

1

2

3

4

5

6

7

8

9



## Engine – Deutz

Item	Part No.	Qty.	Description
1	7624750	1	ENGINE DUETZ F4L-2011F
	8040149	1	ENGINE OIL FILTER
	8040155	1	FUEL FILTER CARTRIDGE
	8040171	1	MUFFLER
	8040165	4	EXHAUST GASKET
2	011157828	1	PUMP SUB ASSEMBLY
3	0081624	1	WLDMT MOTOR MOUNT REAR
4	0081619	1	FRONT MOTOR MOUNT RH
5	0081614	1	FRONT MOTOR MOUNT lh
6	7630779	1	FLEXIBLE COUPLING
7	0081226	1	ENGINE ADAPTER
8	008204528	1	ACTUATOR SUB ASSEMBLY
11	5560207	4	BOLT HEXHD M14 X 2 X 30MM GR8 DR
12	986299	6	WASHER FLAT .375
13	987139	2	WASHER LOCK .500
14	5560356	8	WASHER LOCK M10
15	5560377	8	WASHER LOCK M14
16	5560626	14	BOLT HEXHD M10 X 1.5 X 30MM GR8
17	5560228	4	BOLT HEXHD M10 X 2 X 50MM DRILLED
19	5560168	2	WASHER 1/2 HARD FLAT
20	9980012		.040 STNLS STL LOCKWIRE
21	5560136	2	BOLT LKG .500-16 X 1.25 GR5 DR
23	5560638	2	BOLT HEXHD M8 X 1.25 X 16MM
24	5560355	2	WASHER LOCK M8
25	975209	1	BOLT HEXHD M6 X 1.0 18MM
26	5560628	1	BOLT HEXHD M6 X 1.0 X 12MM
27	984169	1	NUT HEX M6 1.0
28	5560664	2	WASHER LOCK M6
29	0075516	1	PLATE, ACTUATOR MOUNT
30	0075519	1	WLDMT, ACTUATOR MOUNT
31	970369	2	BOLT HEXHD .313-18 1.00
32	5560031	2	NUT HEX LKG .313-18

## Engine – Deutz



## Exhaust and Air Cleaner – Deutz

Item	Part No.	Qty.	Description
1	0071510	2	SPACER
2	0080679	1	TUBE AIR CLEANER INLET
3	0081639	1	TUBE AIR INTAKE
4	0081640	1	EXHAUST PIPE
5	0190805	1	TUBE AIR INLET
6	986299	2	WASHER FLAT .38
7	987119	2	WASHER LOCK .375
8	5560007	1	EXHAUST CLAMP
9	5550050	6	CLAMP WORM DRV #52
10	5560635	2	BOLT 8MM-1.25P 50MM
11	7630004	1	AIR INLET HOOD
12	7630016	1	ELBOW 60 DEG RUBBER
13	7630129	1	ELBOW 90 DEG RUBBER
14	7630140	1	FILTER MINDER KIT
15	7630313	2.30 FT	HOSE 3 IN FLAME RES
16	7630689	1	AIR CLEANER
	8140006	1	ELEMENT
	8140012	1	DUST EJECTOR
	8140014	3	RETAINER CLIP
	8140017	1	COVER

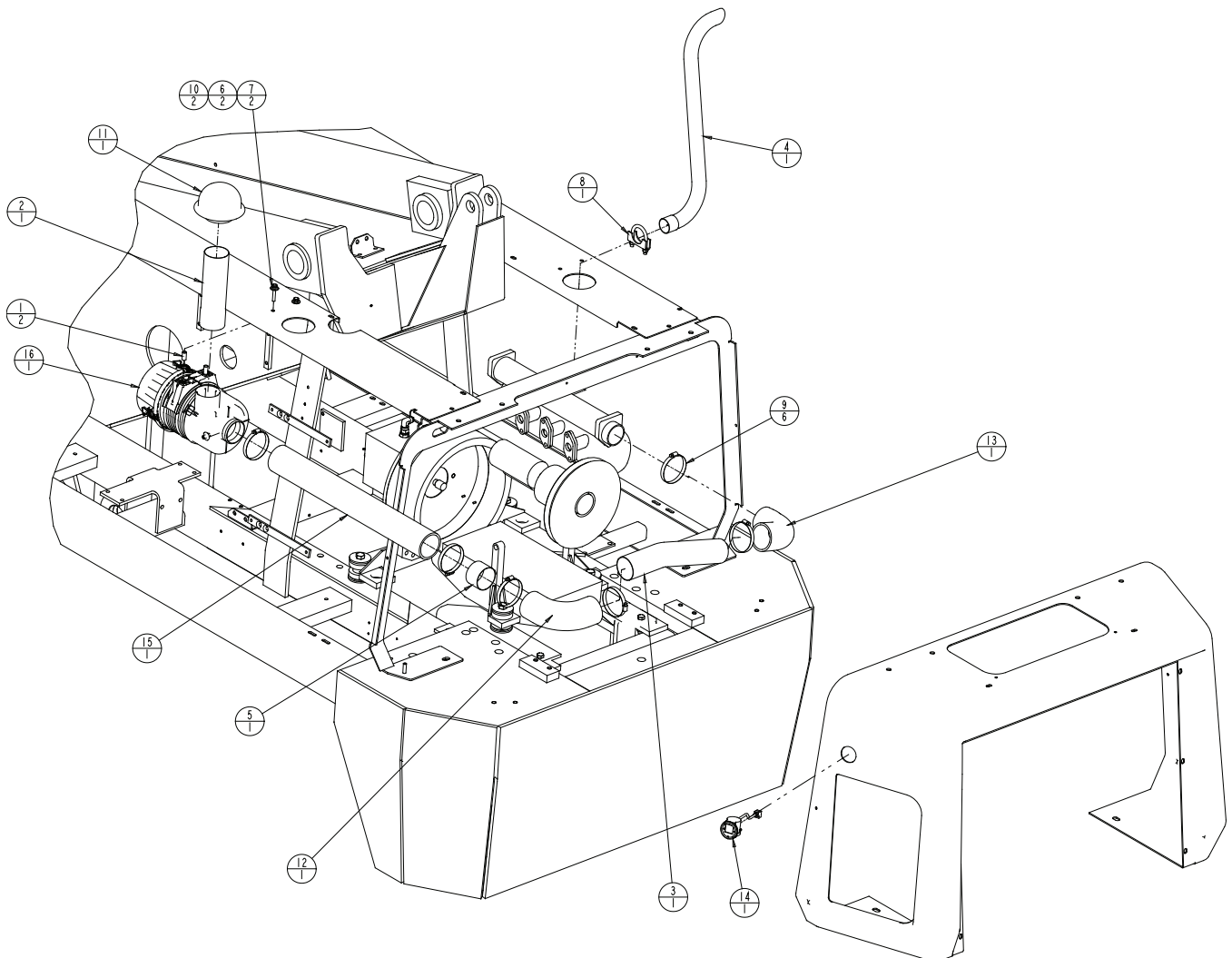

0112400

## Exhaust and Air Cleaner – Deutz



F

E

D

C

B

A

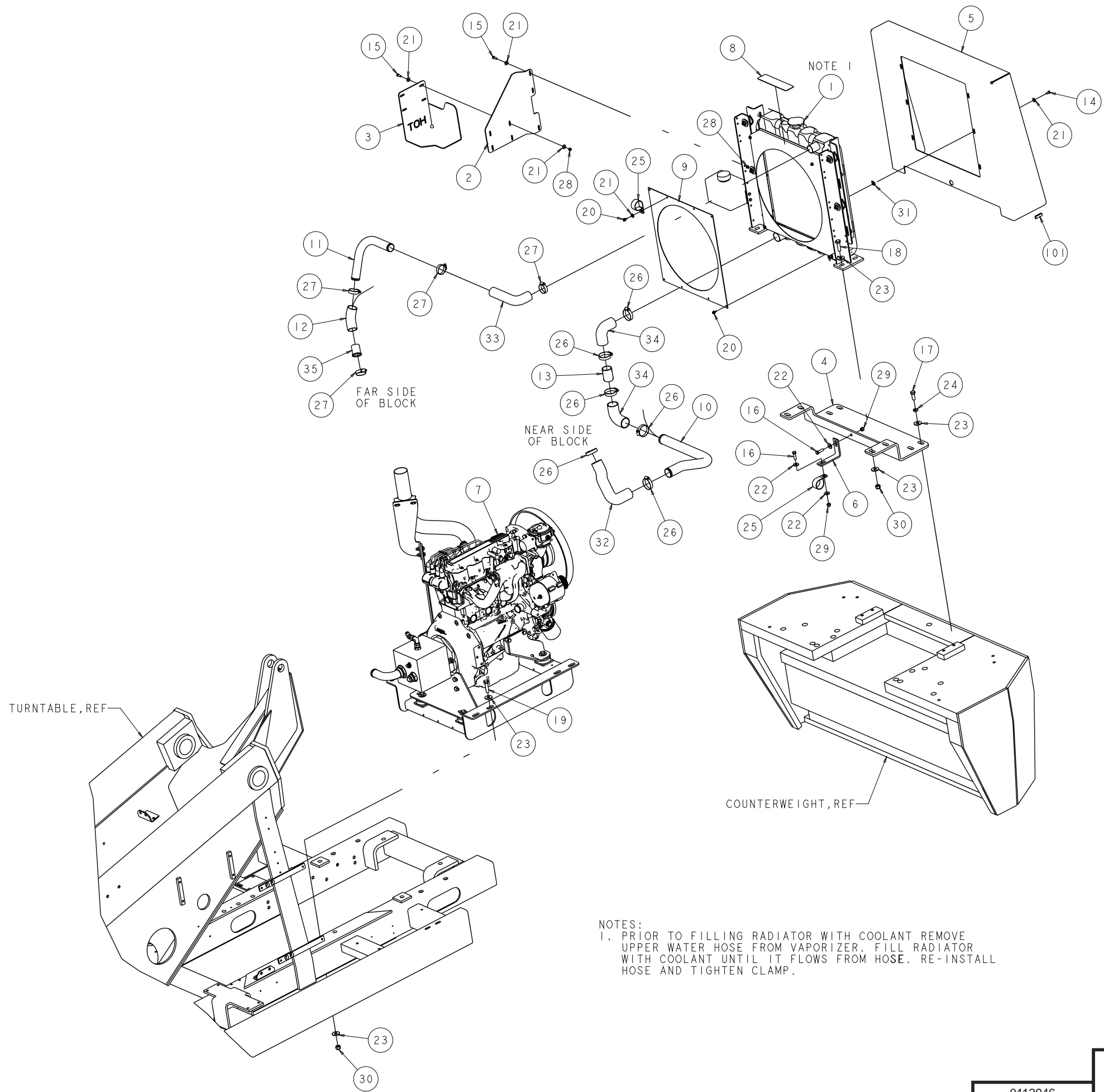

NOTES:  
 1. PRIOR TO FILLING RADIATOR WITH COOLANT REMOVE UPPER WATER HOSE FROM VAPORIZER. FILL RADIATOR WITH COOLANT UNTIL IT FLOWS FROM HOSE. RE-INSTALL HOSE AND TIGHTEN CLAMP.

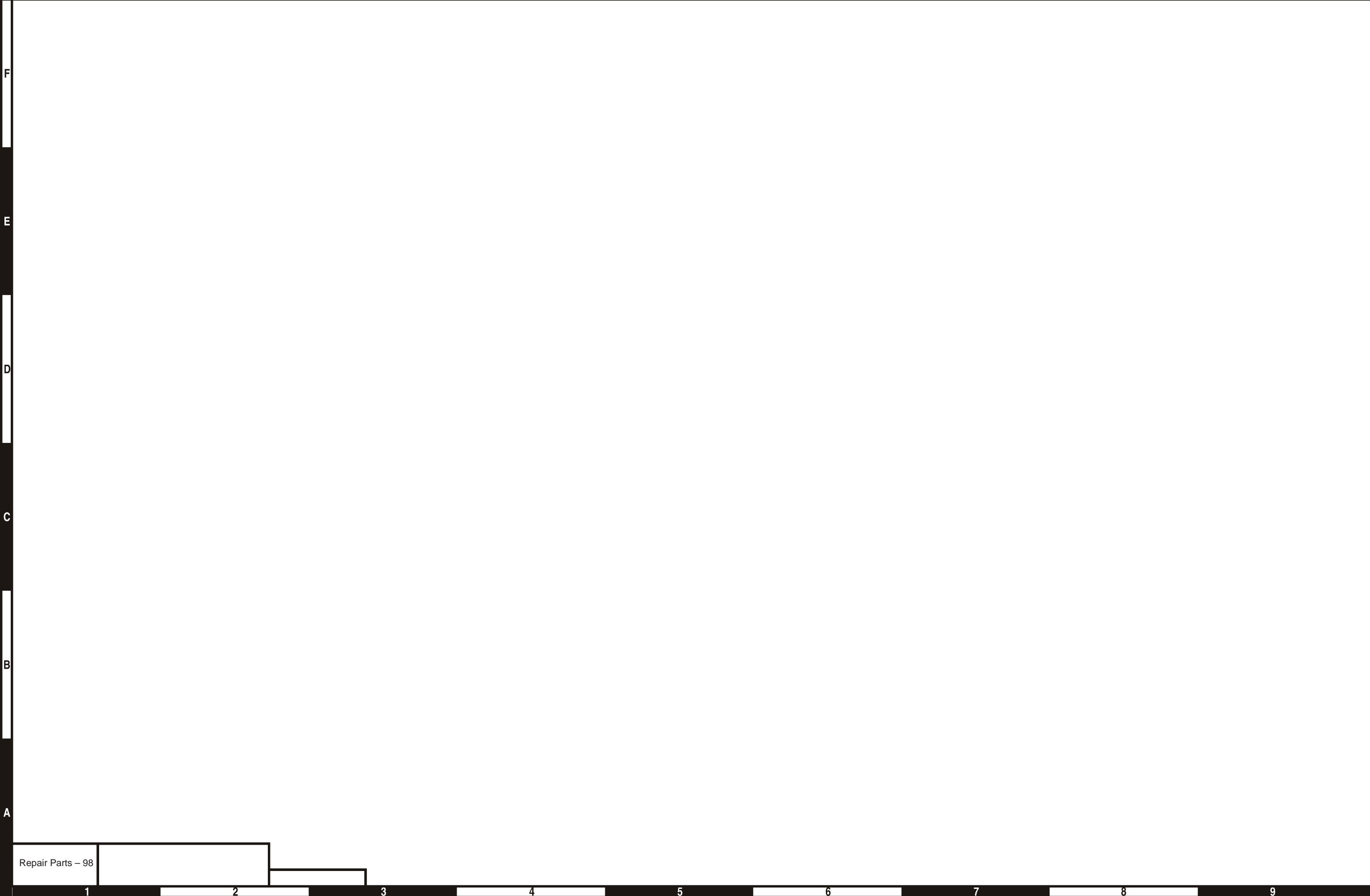

F

E

D

C

B

A

Repair Parts - 98

1

2

3

4

5

6

7

8

9

## Engine Mounting – GM

Item	Part No.	Qty.	Description
1	0084046	1	RADIATOR ASSEMBLY
2	0084080	1	HEAT SHIELD, UPPER
3	0084081	1	HEAT SHIELD, LOWER
4	0112884	1	BRACKET, RADIATOR SUPPORT
5	0112885	1	SHROUD
6	0112890	1	BRACKET, LOWER RADIATOR TUBE
7	0112947	1	ENGINE SUB-ASSEMBLY
8	0163367	1	DECAL, COOLANT FILLING
9	0172395	1	SHROUD
10	0192170	1	TUBE, LOWER RADIATOR 1.75 OD
11	0192172	1	TUBE, UPPER RADIATOR 1.50 OD
12	0192182	1	ELBOW, MOD 45 DEGREES 1.50 ID
13	0192192	1	TUBE UNION 1.75 OD X 2.375 LG
14	970009	6	BOLT, HEXHD .25-20 .500 GR5
15	970029	4	BOLT, HEXHD .25-20 .750 GR5
16	970419	2	BOLT, HEXHD .375-16 1.25 GR5
17	970849	4	BOLT, HEXHD .500-13 1.25 GR5
18	970919	4	BOLT, HEXHD .500-13 1.75 GR5
19	970929	4	BOLT, HEXHD .500-13 2.00 GR5
20	978629	5	SCREW, SLFTPG .25-20 .50
21	986019	18	WASHER, FLAT .250
22	986299	3	WASHER, FLAT .38
23	986259	20	WASHER, FLAT .500
24	987139	4	WASHER, LOCK .500
25	5093012	2	CUSHION CLAMP #28 (1-3/4)
26	5550030	6	CLAMP WORM DRV #32
27	5550038	4	CLAMP WORM DRV #28
28	5560004	7	NUT, LKG .250-20
29	5560033	2	NUT, LKG .375-16
30	5560039	8	NUT, LKG .500-13
31	5569945	6	SPEED NUT 1/4-20 J-STYLE CAGE
32	7630820	1	ELBOW, 1.75 90 DEGREE W/ OFFSET
33	7630821	1	ELBOW, 1.50 90 DEGREE
34	7630833	2	ELBOW, 1.75 90 DEGREE
35	7630835	1	REDUCER, TUBE END 1.50/1.25
101	5560083	1 FT	TRIM-LOCK .125 RUBBER EDGE

## Engine Mounting – GM





NOTES:  
 1. APPLY ANTI-SEIZE SUPPLIED WITH ENGINE  
 TO PUMP SPLINES PRIOR TO INSTALLATION.

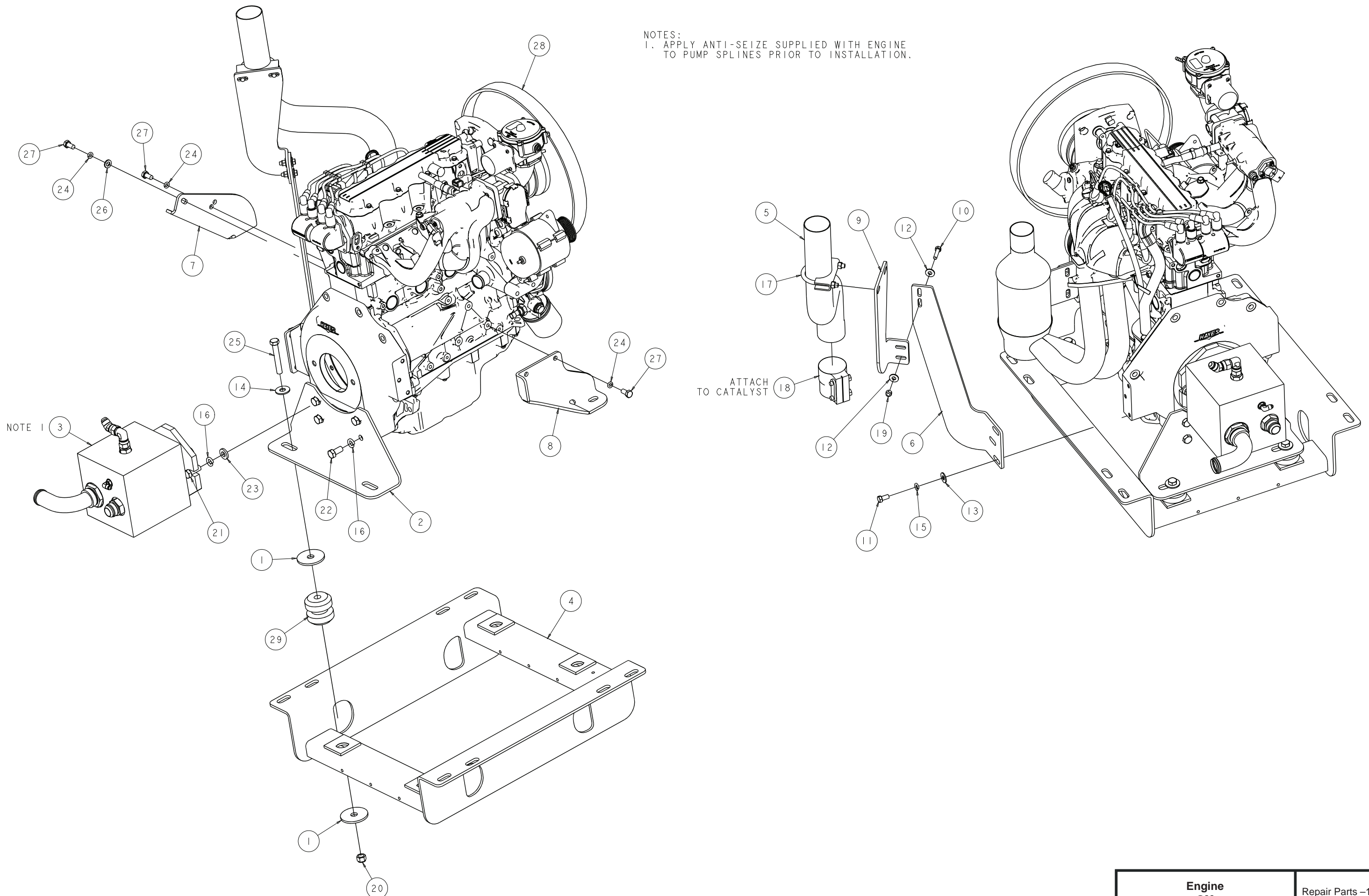

NOTE 1

ATTACH  
 TO CATALYST

F  
E  
D  
C  
B  
A

1 2 3 4 5 6 7 8 9

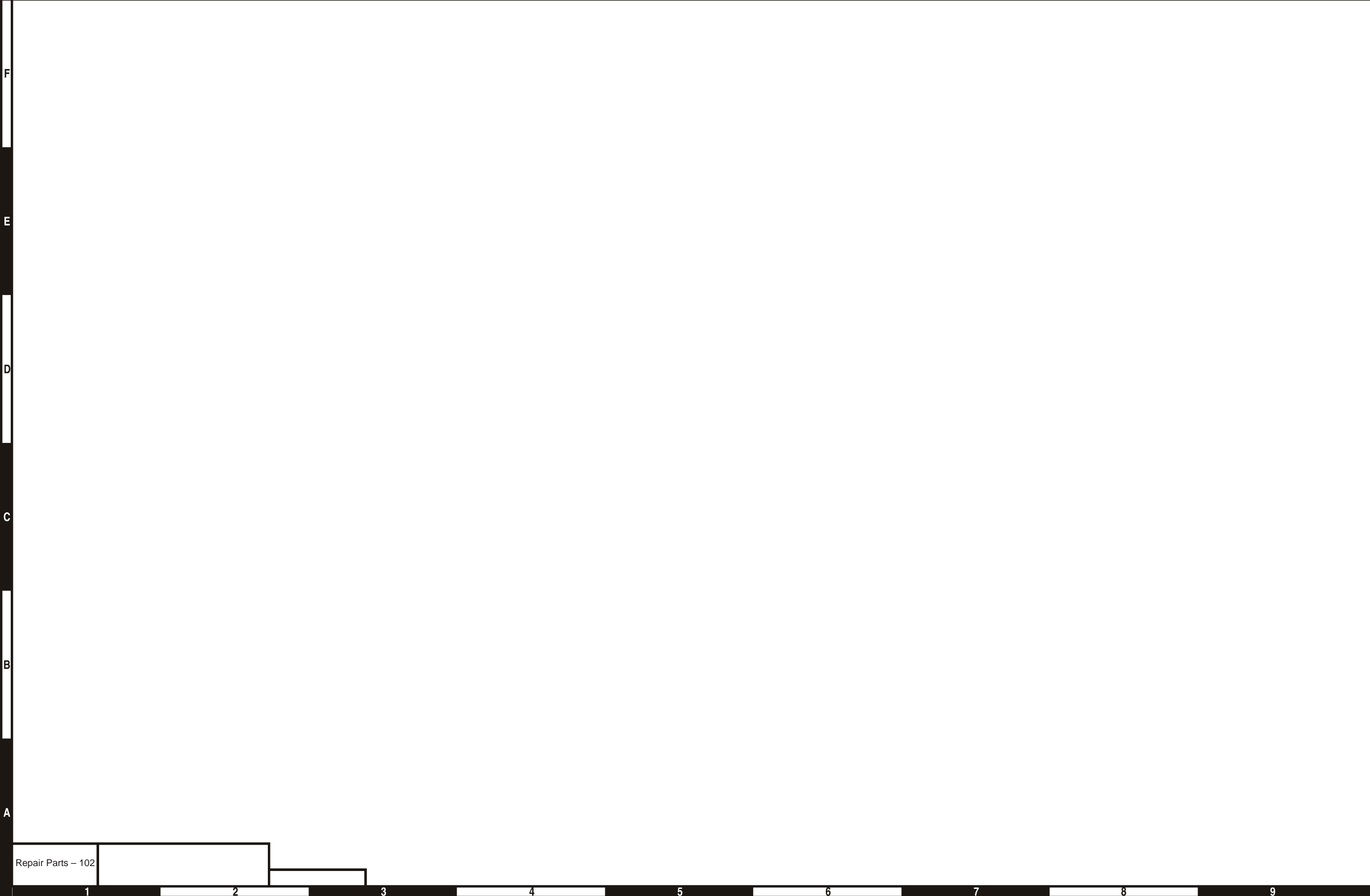

F

E

D

C

B

A

Repair Parts – 102

1

2

3

4

5

6

7

8

9

## Engine – GM

Item	Part No.	Qty.	Description
1	0071599	8	WASHER ENGINE MOUNTING DIESEL
2	0084045	1	MOTOR MOUNT, REAR
3	0111578	1	PUMP SUB ASSEMBLY
4	0112879	1	WELDMENT, ENGINE TRAY
5	0112888	1	TAIL PIPE
6	0112889	1	BRACE, TAILPIPE LOWER
7	0172373	1	MOTOR MOUNT, FRONT LH
8	0172374	1	MOTOR MOUNT, FRONT RH
9	0182115	1	TAILPIPE SUPPORT
10	970269	2	BOLT, HEXHD .313-18 1.25 GR5
11	970449	3	BOLT, HEXHD 375-16 .750 GR5
12	986269	4	WASHER, FLAT .313
13	986299	3	WASHER, FLAT .38
14	986359	4	WASHER, FLAT .500
15	987119	3	WASHER, LOCK .375
16	987139	6	WASHER, LOCK .500
17	5550026	1	EXHAUST CLAMP
18	5554373	1	CLP MUFFLER .250 STEPPED
19	5560031	2	NUT, LKG .313-18
20	5560039	4	NUT, LKG .500-13
21	5560136	2	BOLT, HEXHD .500-13 1.25 GR5 LKG DR
22	5560138	4	BOLT, HEXHD .500-13 1.00 GR5
23	5560168	2	WASHER, HARD FLAT .500 SP
24	5560356	4	WASHER, LOCK M10
25	5560362	4	BOLT, HEXHD .500-13 3.25 GR5
26	5560364	1	WASHER, FLAT M10
27	5560625	4	BOLT, 10MM-1.50P 20MM
28	7624764	1	ENGINE, GM 2.4 T3
29	7630117	4	ENGINE MOUNT

## Engine – GM



## Exhaust and Air Cleaner – GM

Item	Part No.	Qty.	Description
1	0084064	1	ELBOW, MOD 90 DEGREE 2.25 ID
2	0112886	2	SPACER, .50 OD X .43 ID (.035)
3	0112972	1	TUBE 90 DEGREE 2.25 OD
4	0182043	1	TUBE, AIR INLET
5	970309	2	BOLT, HEXHD .313-18 2.25
6	986269	4	WASHER, FLAT .313
7	5550050	6	CLAMP WORM DRV #52
8	5560031	2	NUT, LKG .313-18
9	7630024	1	HOOD, AIR INLET FOR AIR CLEANER
10	7630140	1	FILTER MINDER KIT
11	7630158	2.5 IN	HOSE RADIATOR 2.5 ID BULK
12	7630755	1	AIR CLEANER
13	7630759	1	BRACKET AIR CLEANER
14	7630796	2	DIFFUSER DISK SUPERTRAP (12 PACK)
15	7630797	1	MUFFLER ADAPTER, SUPERTRAP
16	7630838	1	REDUCER STRAIGHT 2.50/2.25 ID

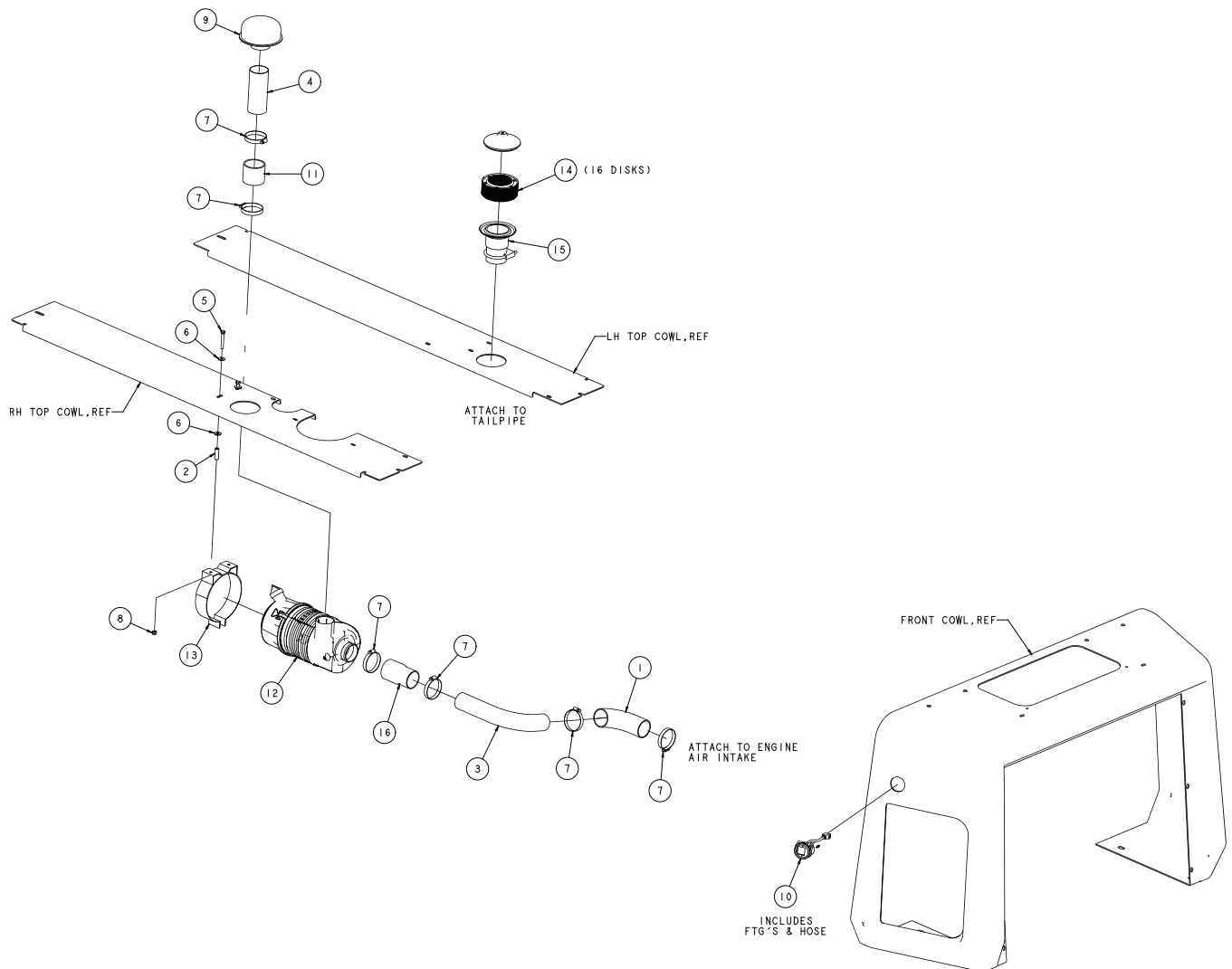

0112949

## Exhaust and Air Cleaner – GM



F

E

D

C

B

A

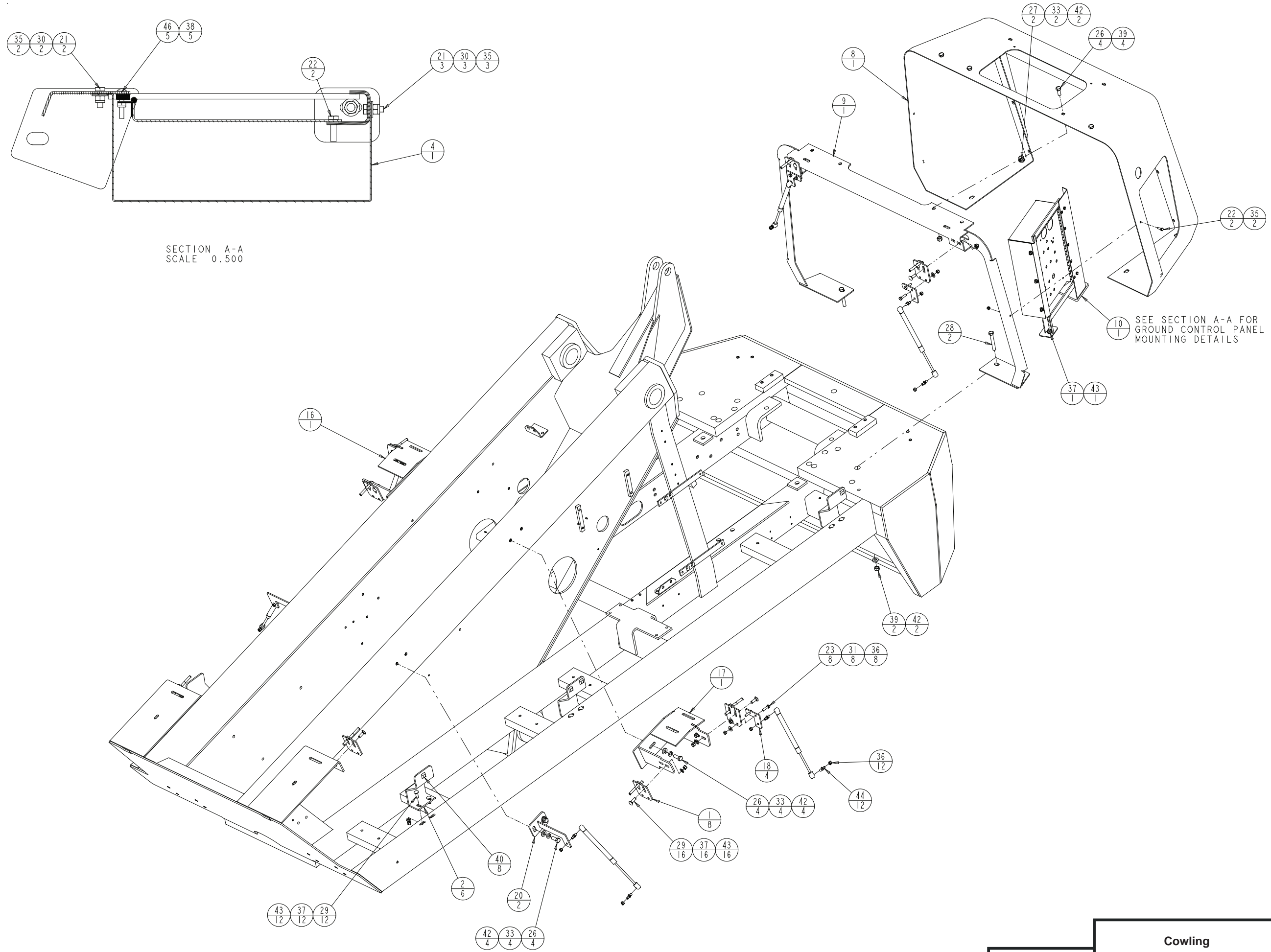

A11034A

Cowling

Repair Parts - 107

1

2

3

4

5

6

7

8

9

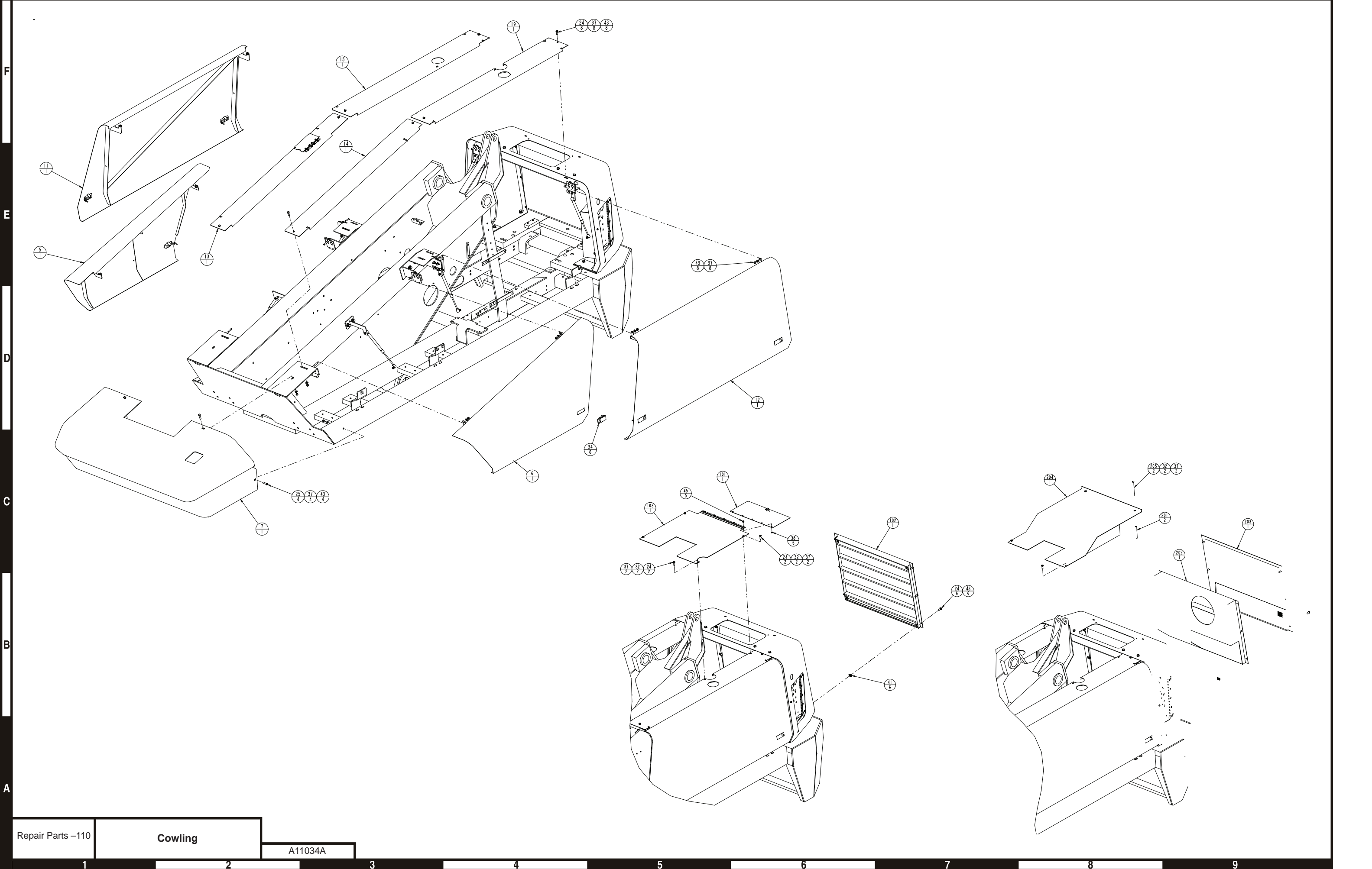



## Cowling

Item	Part No.	Qty.	Description
1	0074408	8	HINGE, DOOR
2	0082303	6	DOOR STOP MIDDLE
3	0082321	6	GAS SPRING 17.1,10.8,105
4	0110483	1	REAR COVER WLDMT GROUND CONTROL BOX
5	0112193	1	WLDMT DOOR LH REAR
6	0112195	1	WLDMT DOOR RH REAR
7	0112196	1	COVER, TURNTABLE REAR
8	0112234	1	COWLING FRONT
9	0112235	1	FRONT COWLING SUPPORT WLDMT
10	0112239	1	WLDMT BOX MOUNT
11	0112242	1	DOOR WLDMT LH FRONT
12	0112244	1	DOOR WLDMT RH FRONT
13	0112248	1	LH REAR COVER
14	0112249	1	COVER REAR
15	0112250	1	COVER LH FRONT
16	0112252	1	BRACKET WLDMT
17	0112253	1	WLDMT BRACKET
18	0112261	4	MOUNT, GAS SPRING
19	0112413	1	WLDMT, COVER
20	0191780	2	WLDMT, GAS SPRING MOUNT
21	970029	5	BOLT .25-20 .750 GR5
22	970049	4	BOLT .25-20 1.00 GR5
23	970269	8	BOLT .313-18 1.25 GR5
24	970469	18	BOLT .375-16 1.00 GR5
25	970489	4	BOLT .375-16 1.50
26	970849	12	BOLT .500-13 1.25 GR5
27	970909	2	BOLT .500-13 1.50 GR5
28	970989	2	BOLT .500-13 3.50 GR5
29	972439	28	BOLT CGR .375-16 1.25
30	986019	5	WASHER FLAT .250
31	986269	8	WASHER FLAT .313
32	986299	6	WASHER FLAT .38
33	987139	10	WASHER LOCK .500
34	5510022	6	LATCH ADJUST LEVER
35	5560004	7	NUT LKG .250-20
36	5560031	20	NUT LKG .313-18
37	5560033	55	NUT LKG .375-16
38	5560034	10	NUT LKG 10-24
39	5560039	6	NUT LKG .500-13
40	5560080	8	BUMPER
41	5560137	6	SPEED NUT .313-18
42	5560168	12	WASHER HARD FLAT .500 SP
43	5560222	55	WASHER HARD FLAT .375 SP
44	5560311	12	BALLSTUD GAS SPRING
45	5560609	5	SCR TRHD 10-24 .50
46	5560610	5	SCR TRHD 10-24 1.25
101	0073481	1	COVER ASSEMBLY
102	0110042	1	SHROUD WLDMT
103	0112268	1	COVER ASSY
201	0073158	2	SPACER SANDBLAST
202	0111756	1	SHROUD, INNER INTAKE
203	0111757	1	AIR INTAKE SHROUD WLDMT
204	0112397	1	WLDMT, COVER
205	5560645	2	BOLT .375-15 5.00 GR5

## Cowling



F  
E  
D  
C  
B  
A

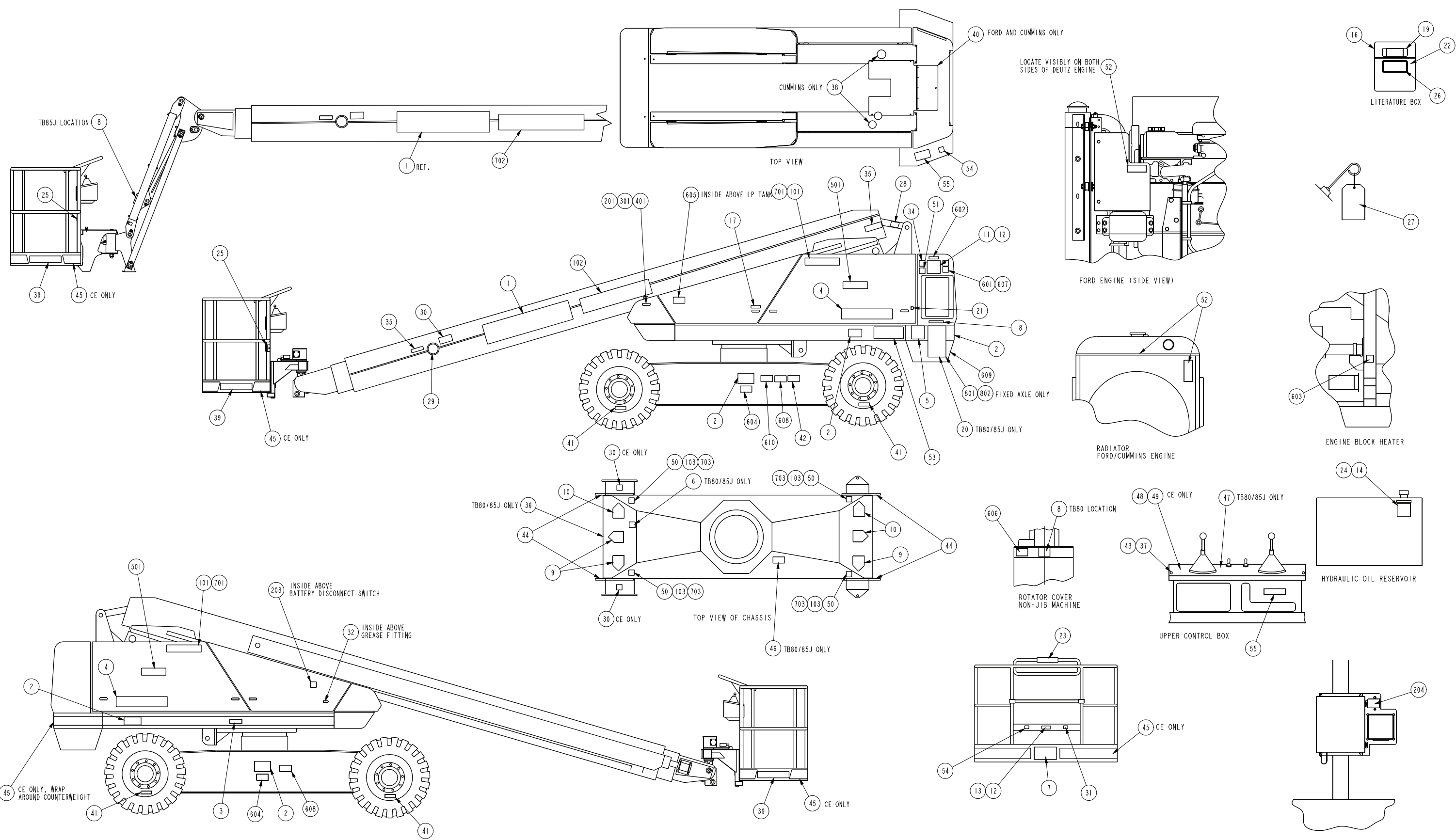

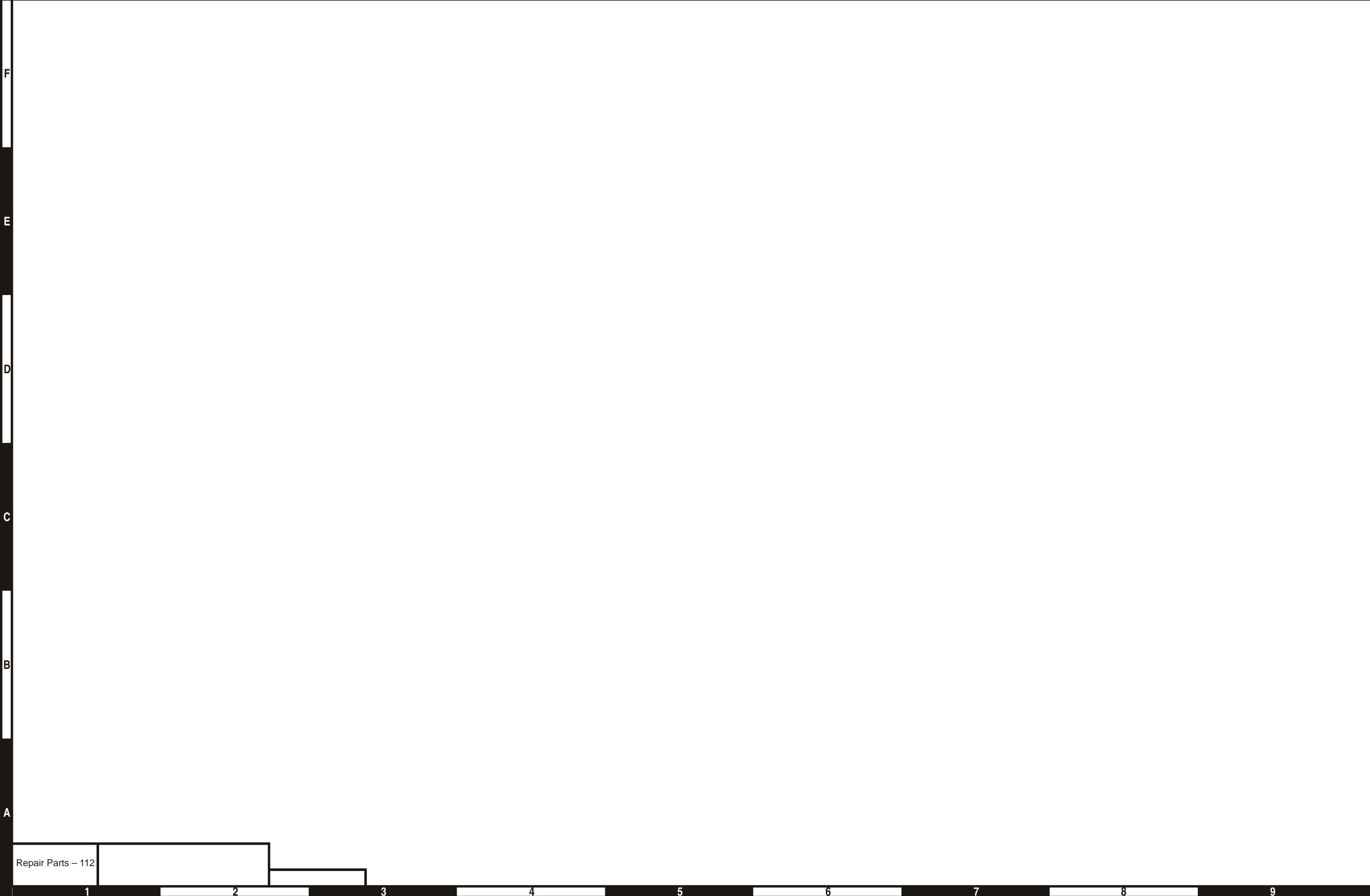

F

E

D

C

B

A

Repair Parts – 112

1

2

3

4

5

6

7

8

9

## Placards and Decals

Item	Part No.	Qty.	Description
1	0083733	1	DECAL SNORKEL BRAND LOGO
2	0323896	5	DECAL, DANGER ELECTRICAL HAZARD
	0162336E	5	DECAL DNGR ELEC HAZARD - CE ONLY
	0162366	5	DECAL DNGR ELEC HAZARD - CE ONLY
	0162336F	5	DECAL DNGR ELEC HAZARD - FRENCH ONLY
	0162366	5	DECAL DNGR ELEC HAZARD - FRENCH ONLY
	0162336P	5	DECAL DNGR ELEC HAZARD - SPANISH ONLY
	0162366	5	DECAL DNGR ELEC HAZARD - SPANISH ONLY
	0162336W	5	DECAL DNGR ELEC HAZARD - SWEDISH ONLY
	0162366	5	DECAL DNGR ELEC HAZARD - SWEDISH ONLY
	0162336D	5	DECAL DNGR ELEC HAZARD - DUTCH ONLY
	0162366	5	DECAL DNGR ELEC HAZARD - DUTCH ONLY
	0162336G	5	DECAL DNGR ELEC HAZARD - GERMAN ONLY
	0162366	5	DECAL DNGR ELEC HAZARD - GERMAN ONLY
3	0070420	1	PLACARD, EMERGENCY BLEED DOWN VALVE
4	0074908	2	DECAL, SNORKEL BRAND LOGO
5	0323897	1	DECAL, DANGER YOU MUST NOT OPERATE
7		1	PLACARD, PLATFORM CAPACITY (CONSULT FACTORY)
8	0323899	1	DECAL, DANGER ELECTRICAL HAZARD
	0162366	1	DECAL DNGR ELEC HAZARD - CE ONLY
	0162336E	1	DECAL DNGR ELEC HAZARD - CE ONLY
	0162366	1	DECAL DNGR ELEC HAZARD - FRENCH ONLY
	0162336F	1	DECAL DNGR ELEC HAZARD - FRENCH ONLY
	0162366	1	DECAL DNGR ELEC HAZARD - SPANISH ONLY
	0162336P	1	DECAL DNGR ELEC HAZARD - SPANISH ONLY
	0162366	1	DECAL DNGR ELEC HAZARD - SWEDISH ONLY
	0162336W	1	DECAL DNGR ELEC HAZARD - SWEDISH ONLY
	0162366	1	DECAL DNGR ELEC HAZARD - DUTCH ONLY
	0162336D	1	DECAL DNGR ELEC HAZARD - DUTCH ONLY
	0162366	1	DECAL DNGR ELEC HAZARD - GERMAN ONLY
	0162336G	1	DECAL DNGR ELEC HAZARD - GERMAN ONLY
9	0070540	3	DECAL, YELLOW ARROW
10	0070541	3	DECAL, BLUE ARROW
11	0070901	1	PLACARD, CAUTION SERIAL NUMBER
12	5560655	12	POP RIVET
13	0071425	1	PLACARD, PLATFORM IDENTIFICATION
14	0071927	1	DECAL, HYDRAULIC OIL
16	562386	1	LITERATURE COMPARTMENT
17	0073419	1	DECAL, SAFE OPERATION INFORMATION
18	0181562	1	PLACARD, ANSI STANDARD
19	0073224	1	DECAL, NOTICE MANUAL REORDER
20	0190988	1	PLACARD, GROUND CONTROL INSTRUCTIONS
	0190988E	1	PLACARD, GROUND CONTROL INSTRUCTIONS - CE ONLY
	0190988F	1	PLACARD, GROUND CONTROL INSTRUCTIONS - FRENCH ONLY
	0190988P	1	PLACARD, GROUND CONTROL INSTRUCTIONS - SPANISH ONLY
	0190988W	1	PLACARD, GROUND CONTROL INSTRUCTIONS - SWEDISH ONLY
	0190988D	1	PLACARD, GROUND CONTROL INSTRUCTIONS - DUTCH ONLY
	0190988G	1	PLACARD, GROUND CONTROL INSTRUCTIONS - GERMAN ONLY
21	5560080	8	BUMPER
22	7050004	1	RECORD POUCH
23	0072531	1	DECAL, DANGER ELECTRICAL HAZARD
24	7030003	1	DECAL, LUBE RECOMMENDATIONS
25	0070921	1	PLACARD, 125 VOLT 15 AMPS
26	0073043	1	DECAL, OPERATING MANUAL ENCLOSED
27	0073139	1	CRANKCASE OIL TAG – USED FOR SHIPPING ONLY
28	0074311	7	DECAL, DANGER CYLINDER FAILURE – 1 PER CYLINDER
29	9980013	2	CAP
30	0190989	1	DECAL, DANGER DO NOT REACH ( QTY 3 FOR CE MACHINE)

## Placards and Decals

## Placards and Decals

Item	Part No.	Qty.	Description
31	0172451	1	DECAL, ATTACH FALL RESTRAINT
32	0073492	1	DECAL, ROTATE WHILE GREASING
	0073492F	1	DECAL ROTATE WHILE GREASING - FRENCH ONLY
	0073492P	1	DECAL ROTATE WHILE GREASING - SPANISH ONLY
	0073492W	1	DECAL ROTATE WHILE GREASING - SWEDISH ONLY
	0073492D	1	DECAL ROTATE WHILE GREASING - DUTCH ONLY
	0073492G	1	DECAL ROTATE WHILE GREASING - GERMAN ONLY
33	0073921	16 FT	DECAL, 4 INCH STRIPE
34	0074372	1	PLACARD, ENGINE RPM
	0074372F	1	PLACARD ENGINE RPM - FRENCH ONLY
	0074372P	1	PLACARD ENGINE RPM - SPANISH ONLY
	0074372W	1	PLACARD ENGINE RPM - SWEDISH ONLY
	0074372D	1	PLACARD ENGINE RPM - DUTCH ONLY
	0074372G	1	PLACARD ENGINE RPM - GERMAN ONLY
35	0073667	2	DECAL, INSPECT WIRE ROPES
36	451986	1	DECAL, DANGER DO NOT ALTER
	451986F	1	DECAL, DANGER DO NOT ALTER - FRENCH ONLY
	451986P	1	DECAL, DANGER DO NOT ALTER - SPANISH ONLY
	451986W	1	DECAL, DANGER DO NOT ALTER - SWEDISH ONLY
	451986D	1	DECAL, DANGER DO NOT ALTER - DUTCH ONLY
	451986G	1	DECAL, DANGER DO NOT ALTER - GERMAN ONLY
37	5560004	2	NUT, .250-20 ESNA
38	9980022		PLUG, 4.0 DIA
39	569295	2	DECAL, SNORKEL BRAND LOGO
40	5569012	4	RUBBER BUMPER
42	0162311	1	DECAL, CE LOGO - CE ONLY
41	0072276	4	PLACARD, LUG NUT TORQUE
43	970009	2	BOLT .25-20 X .5 HH GR5
44	0083427	4	DECAL, TIE DOWN SYMBOL
45	7030001	35 FT	WARNING STRIPE, CE ONLY
46	0111343	1	DECAL, HIGH SPEED RANGE SP SEL VALVE
47	0111342	1	DECAL, HISH SPEED RANGE SP SEL LOCATION
48		1	DECAL, ADDITIONAL OPERATION INSTRUCTIONS
49		1	DECAL, ADDITIONAL OPERATING INSTRUCTIONS
	0162329E	1	DECAL PRE-START INSTR - CE ONLY
	0162328E	1	DECAL PRE-START INSTR - CE ONLY
	0162329F	1	DECAL PRE-START INSTR - FRENCH ONLY
	0162328F	1	DECAL PRE-START INSTR - FRENCH ONLY
	0162329P	1	DECAL PRE-START INSTR - SPANISH ONLY
	0162328P	1	DECAL PRE-START INSTR - SPANISH ONLY
	0162329W	1	DECAL PRE-START INSTR - SWEDISH ONLY
	0162328W	1	DECAL PRE-START INSTR - SWEDISH ONLY
	0162329D	1	DECAL PRE-START INSTR - DUTCH ONLY
	0162328D	1	DECAL PRE-START INSTR - DUTCH ONLY
	0162329G	1	DECAL PRE-START INSTR - GERMAN ONLY
	0162328G	1	DECAL PRE-START INSTR - GERMAN ONLY
51		1	DECAL, CE NOISE LEVEL - CE ONLY
52	0161410	3	DECAL, DANGER ROTATING PARTS
	0151410E		DECAL DNGR ROTATING PARTS - CE ONLY
	0151410F		DECAL DNGR ROTATING PARTS - FRENCH ONLY
	0151410P		DECAL DNGR ROTATING PARTS -SPANISH ONLY
	0151410W		DECAL DNGR ROTATING PARTS - SWEDISH ONLY
	0151410D		DECAL DNGR ROTATING PARTS - DUTCH ONLY
	0151410G		DECAL DNGR ROTATING PARTS - GERMAN ONLY
53	0112188	1	DECAL, LIFT TIE DOWN LOCATION
54	0075235	4	DECAL, SIDE LOADING
55		1	PLACARD, PLATFORM CAPACITY (CONSULT FACTORY)
101	0112475	2	DECAL, TB80 LOGO – TB80 ONLY
102	0112474	1	DECAL, 80 LOGO – TB80 ONLY

## Placards and Decals

## Placards and Decals

Item	Part No.	Qty.	Description
103		4	DECAL, WHEEL LOADING FIXED AXLE – TB80 ONLY
301	0071926	1	DECAL, DIESEL FUEL – CUMMINS ENGINE
401	0071926	1	DECAL, DIESEL FUEL – DUETZ ENGINE
501	0074913	2	DECAL, 4X4 LOGO
601	0081377	1	DECAL, LPS LOGO – LP FUEL ONLY
602	0071793	1	DECAL, HYDRAULIC WARM UP INSTRUCTIONS – OPTION ONLY
603	0181634	1	DECAL, ENGINE BLOCK HEATER – OPTIONS
604	0073298	2	PLACARD, DANGER FOAM FILLED TIRES – OPTIONS
	0073298F		PLACARD DANGER FOAM FILLED TIRES - FRENCH ONLY OPTION
	0073298P		PLACARD DANGER FOAM FILLED TIRES - SPANISH ONLY OPTION
	0073298W		PLACARD DANGER FOAM FILLED TIRES - SWEDISH ONLY OPTION
	0073298D		PLACARD DANGER FOAM FILLED TIRES - DUTCH ONLY OPTION
	0073298G		PLACARD DANGER FOAM FILLED TIRES -GERMAN ONLY OPTION
605	0081441	1	DECAL, CAUTION LIQUID WITHDRAWL – OPTION
606	0082164	1	DANGER, DO NOT RIDE – OPTION
607	0090493	1	DECAL, DUAL FUEL INSTRUCTIONS – OPTION
608	0072203	2	DECAL, TOWING INSTRUCTIONS – OPTION
609	0082203	1	DECAL, DANGER CRUSHING HAZARD – OPTION
610	0082160	1	PLACARD, DANGER TOW PACKAGE – OPTION
701	0112567	2	DECAL, TB85J LOGO – T85J ONLY
702	0112568	1	DECAL, 85J LOGO – T85J ONLY
703		2	DECAL, WHEEL LOADING FIXED AXLE – T85J ONLY
801	0074209	1	DECAL PRESTART INSTRUCTIONS
802	0074210	1	DECAL DANGER ELEC/TIPPING HAZARD

## Placards and Decals





# Gear Hub – Auburn Gear

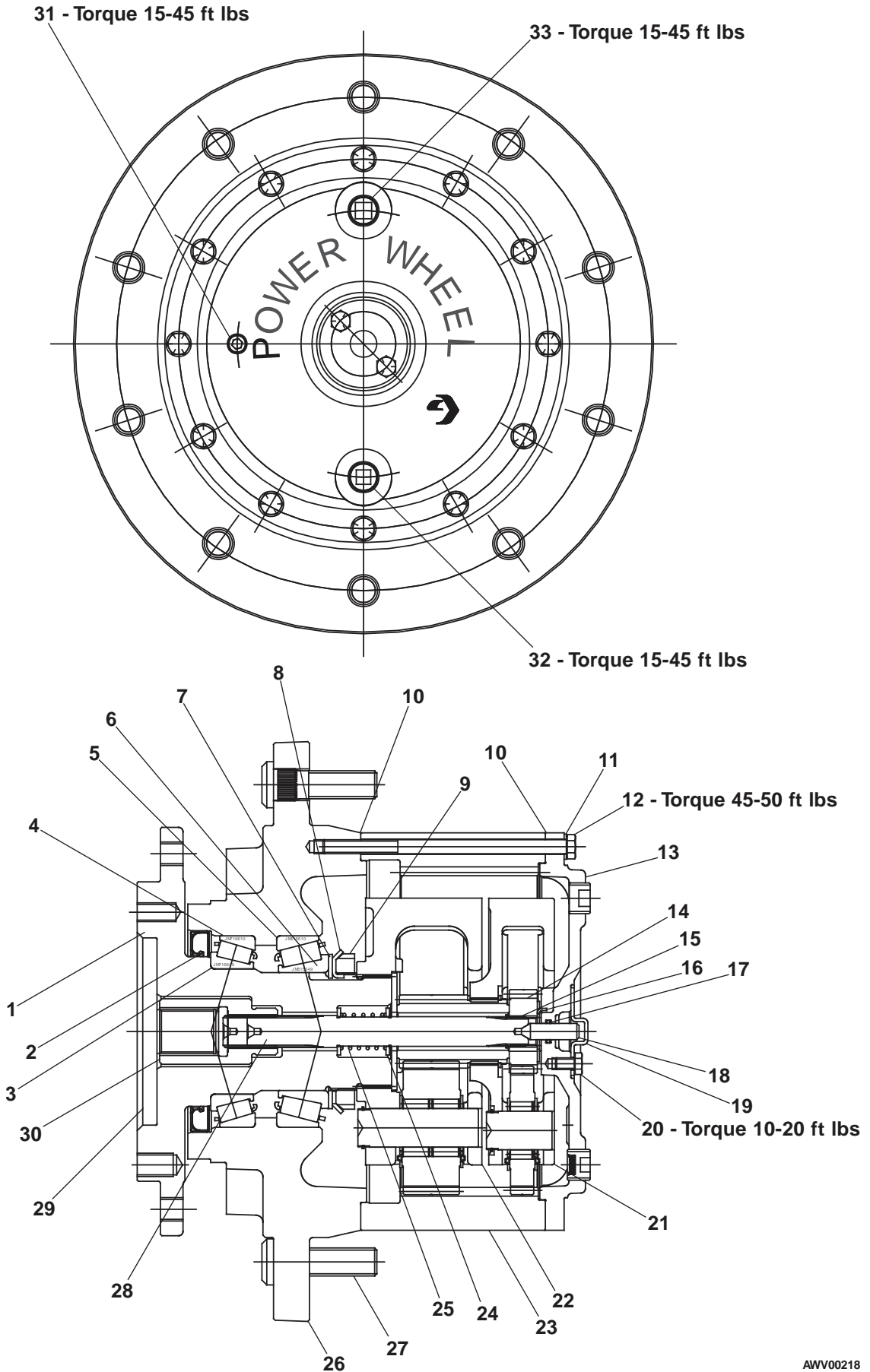

# Gear Hub – Auburn Gear

AWV00218

## Gear Hub – Auburn Gear

Item	Part No.	Qty.	Description
	0180961	1	GEAR HUB, AUBURN
1	0112216	1	SPINDLE
2	8010027	1	OIL SEAL
3	8010030	1	BEARING CONE
4	8010029	1	BEARING CUP
5	0112217	1	BEARING CUP
6	0112218	1	BEARING CONE
7	8010275	1	THRUST WASHER
8	8010276	1	LOCK WASHER
9	8010277	1	LOCK NUT
10	8010021	1	PIPE PLUG
11	8010105	12	FLAT WASHER
12	8010278	12	CAPSCREW, HEX HEAD
13	0112219	1	COVER
14	0112220	1	PRIMARY SUN GEAR
15	8010145	2	RETAINING RING
16	8010075	1	THRUST WASHER
17	8070149	1	O-RING
18	8010143	1	PLUNGER
19	8010080	1	DISENGAGE COVER
20	8070168	2	CAPSCREW, HEX HEAD
21	0112221	1	PRIMARY CARRIER
22	0112222	1	SECONDARY CARRIER
23	0112223	1	RING GEAR
24	8010279	2	THRUST WASHER
25	0112224	1	DISENGAGE SPRING
26	0112225	1	HUB
27	8010280	10	WHEEL BOLT
28	0112226	1	INPUT SHAFT
29	8010281	1	SHIPPING PLUG
30	8010138	1	COUPLING
31	0112227	1	PIPE PLUG
32	8010028	1	PIPE PLUG
33	8010021	1	MAGNETIC PLUG

## Gear Hub – Auburn Gear

# Swing Drive – Perfection Gear

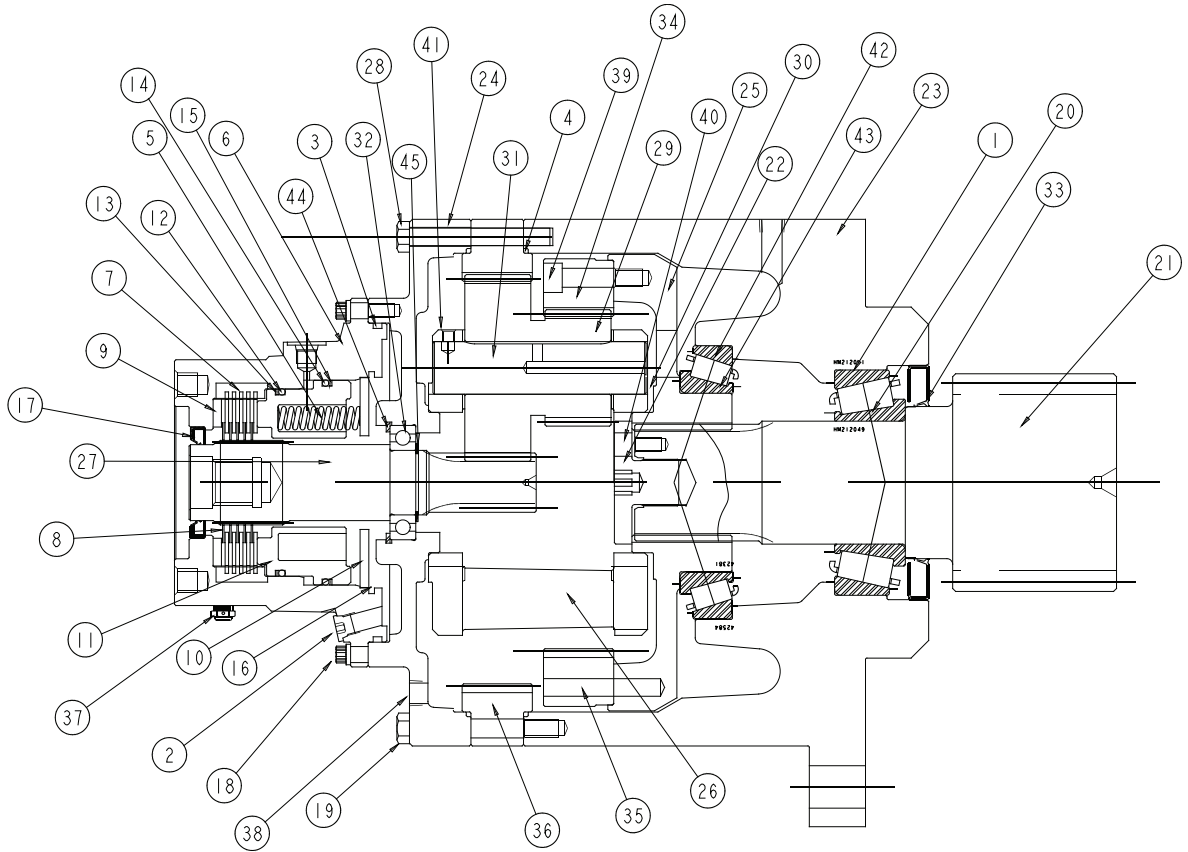

NOTES:  
SPECIAL CARE MUST BE TAKEN WHEN DISASSEMBLING THE SWING DRIVE.  
INTERNAL GEARS MUST BE ORIENTED PROPERLY. CONTACT SNORKEL FOR MORE INFORMATION

0112233

# Swing Drive – Perfection Gear

## Swing Drive – Perfection Gear

Item	Part No.	Qty.	Description
	0112233	1	PLANETARY SWING DRIVE WITH BRAKE
	0112316	1	SEAL REPAIR KIT
1	0172033	1	BEARING CUP
2	0112273	2	PLUG, O-RING
3	KIT ITEM	1	O-RING (NOT SOLD SEPARATELY)
4	KIT ITEM	1	O-RING (NOT SOLD SEPARATELY)
5	0112276	11	SPRING
6	0112277	1	HOUSING
7	0112278	5	PRESSURE DISC
8	0112279	1	PRESSURE DISC
9	0112280	1	PRESSURE PLATE
10	0112281	1	PRESSURE PLATE
11	0112282	1	BRAKE PISTON
12	KIT ITEM	1	O-RING (NOT SOLD SEPARATELY)
13	0112284	1	BACK-UP RING
14	KIT ITEM	1	O-RING (NOT SOLD SEPARATELY)
15	0112286	1	BACK-UP RING
16	0112292	1	SNAP RING, INTERNAL
17	KIT ITEM	1	OIL SEAL (NOT SOLD SEPARATELY)
18	0112287	8	CAPSCREW 5/16-18 X 7/8
19	0112288	8	CAPSCREW 3/8-16 X 3
20	0112289	1	BEARING CONE
21	0112290	1	PINION
22	0112297	1	PINION BOLT
23	0112293	1	HOUSING
24	0112294	1	BRAKE ADAPTER
25	0112295	1	DRIVE WEB
26	0112296	1	CARRIER
27	0112297	1	INPUT PINION
28	0112298	4	CAPSCREW 3/8-16 X 3
29	0112299	3	PLANET GEAR
30	0112300	1	THRUST WASHER
31	0112301	3	IDLER PIN
32	0112303	1	BALL BEARING
33	KIT ITEM	1	OIL SEAL (NOT SOLD SEPARATELY)
34	0112304	3	ROLL PIN 3/8 ID X 2
35	0112305	1	RING GEAR, 72 TEETH
36	0112306	1	RING GEAR, 87 TEETH
37	0172053	1	PRESSURE VENT PLUG
38	0172050	2	PIPE PLUG
39	0112308	12	CAPSCREW 3/8-16 X 1-1/2
40	0112309	1	CAPSCREW 5/16-18 X 1/2
41	0112310	3	CAPSCREW 1/4-20 X 1/2
42	0112311	1	BEARING CUP
43	0112312	1	BEARING CONE
44	0112313	1	SNAP RING, INTERNAL
45	0112314	1	SNAP RING, EXTERNAL

## Swing Drive – Perfection Gear

## Tires and Wheels

Item	Part No.	Qty.	Description
1	0112657	2	4X4, 15-625 FOAM FILLED TIRES AND WHEELS
2	0112658	2	TIRE AND WHEEL, FOAM FILLED RIGHT HAND DRIVE
3	0073298	4	DECAL, DANGER FOAM FILLED TIRES

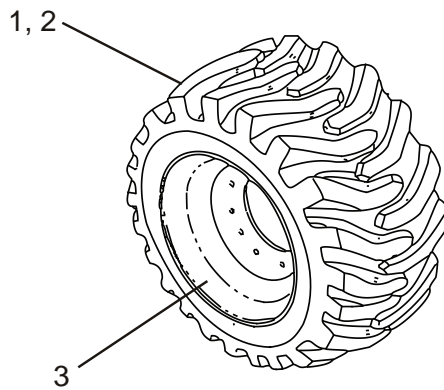

## Tires and Wheels



# *Hydraulics*

TB80

TB85J



**snorkel**





F

E

D

C

B

A

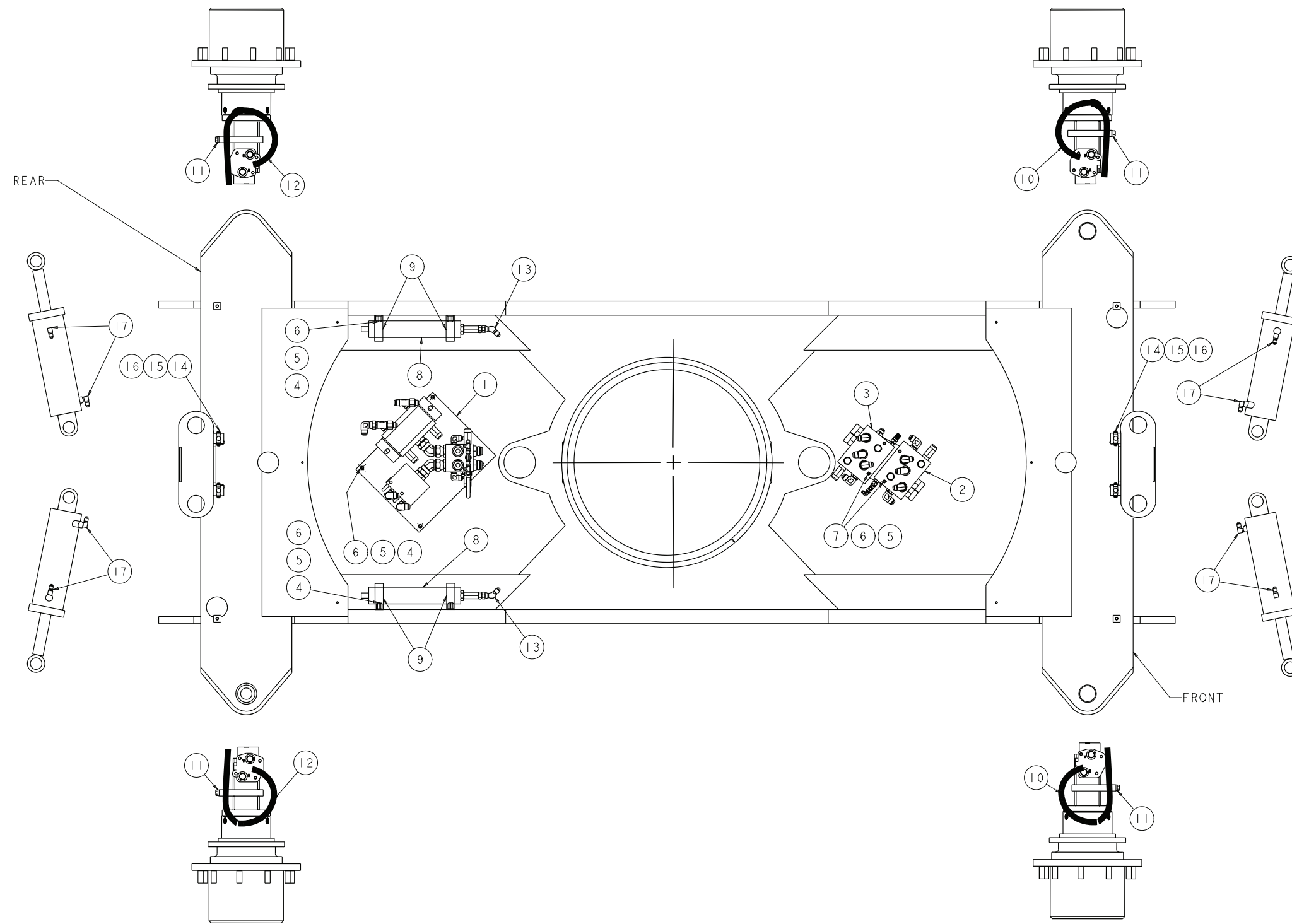

1

2

3

4

5

6

7

8

9

0112749

Chassis Hydraulics

Hydraulics - 3

F

E

D

C

B

A

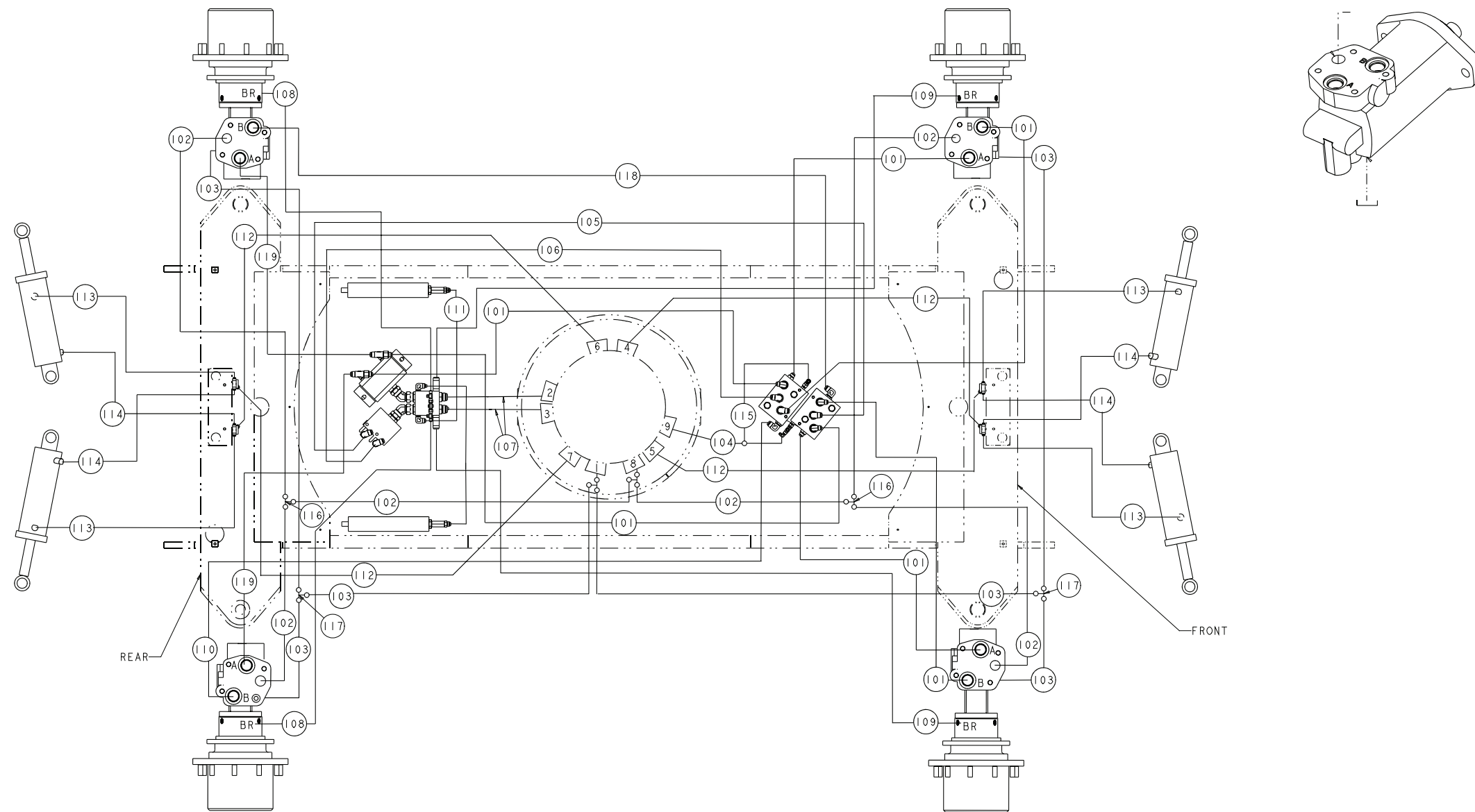

REAR

FRONT

## Chassis Hydraulics

Item	Part No.	Qty.	Description
1	0112807	1	FLOW DIV. MOTION CTRL VALVE SUB ASSEMBLY
2	0112805	1	FRONT TRANS. VALVE SUBASSY
3	0112806	1	REAR TRANS. VALVE SUBASSY
4	970449	7	BOLT, HEXHD .375-16 .75 GR5
5	986299	11	WASHER FLAT .375
6	987119	11	WASHER LOCK .375 MDM
7	970449	4	BOLT HEXHD .375-16 .75 GR5
8	0181083	2	ACCUMULATOR SUB ASSY
9	5093014	2	CLP CUSHION 2.25
10	5090034	6 FT	SLEEVE,HOSE ABRASION GRD 1.81"
11	5550070	4	CLP WORM DRV 3.00-5.00 SAE#72
12	5098339	6 FT	SLEEVE,HOSE ABRASION GRD 2.38"
13	5036906	2	FTG ELB45SWVL-8S-8S STL
14	5035005	4	FTG TEE BHD BR-6S-6S STL
15	5037005	4	FTG ELB90SWVL-6S-6S STL
16	5074405	4	FTG LKNT BHD-6 STL
17	5035305	8	FTG ELB90STRTHD-6B-6S STL
101	0180784	6	HOSE -8-8S-8S 72
102	0180945	6	HOSE -4-4S-4S 62 100R2
103	0060305	6	HOSE -6-6S-6S 41
104	0050400	1	HOSE -6-6S-6S 41
105	0112705	1	HOSE -10-10S-10S 78
106	0180779	1	HOSE -10-10S-10S 70
107	0112827	2	HOSE -16-16S45-16S 26 100R12
108	0111287	2	HOSE - 4 - 4S - 4S 84 100R2
109	0100491	2	HOSE -4-4S-4S 150
110	0112706	1	HOSE -10-10S-10S 132
111	0070792	2	HOSE -8-8S-8S 32 100R2
112	0070789	4	HOSE -6-6S-6S 75.5 100R2
113	0020275	4	HOSE -6-6S-6S 16 100R2
114	463374	4	HOSE -6-6S-6S 13 100R2
115	0070786	1	HOSE -6-6S-6S 19 100R2
116	5034102	2	FTG TEE UN-4S-4S STL
117	5034104	2	FTG TEE UN-6S-6S STL
118	0112830	1	HOSE -10-10S-10S 146.5
119	0112828	2	HOSE -10-10S-10S 70 100R16

## Chassis Hydraulics



NOTES:  
 1. ITEMS 48 AND 54 HOSES CALLED OUT FOR CONNECTION PURPOSES.  
 ACTUAL QTY OF EACH HOSE IS 1 AND IS CALLED OUT ON ENGINE  
 INSTALLATIONS 0111961, 0111741, 0111773, 0111963.

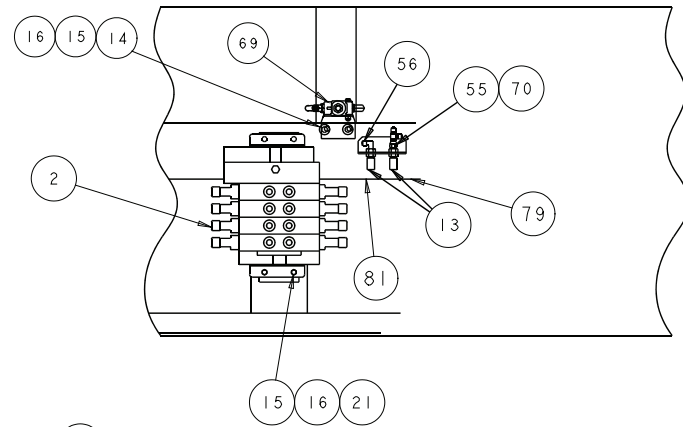

VIEW B-B

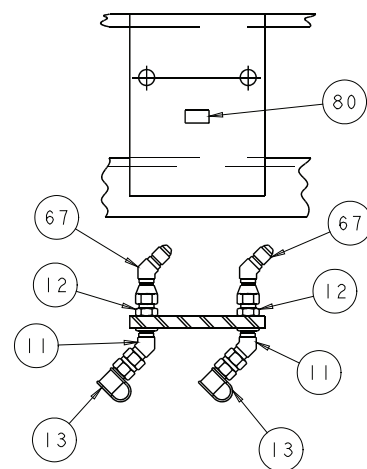
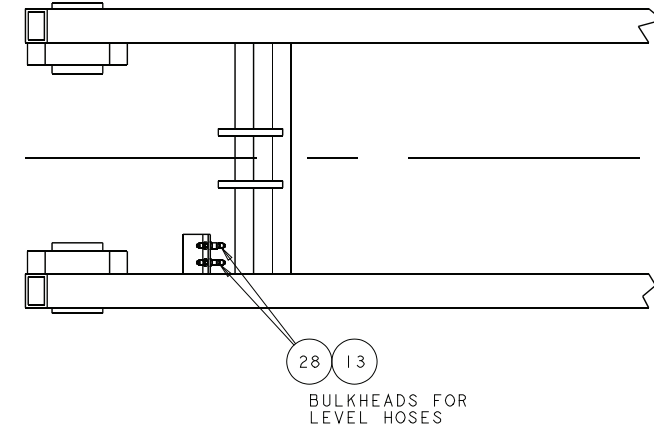
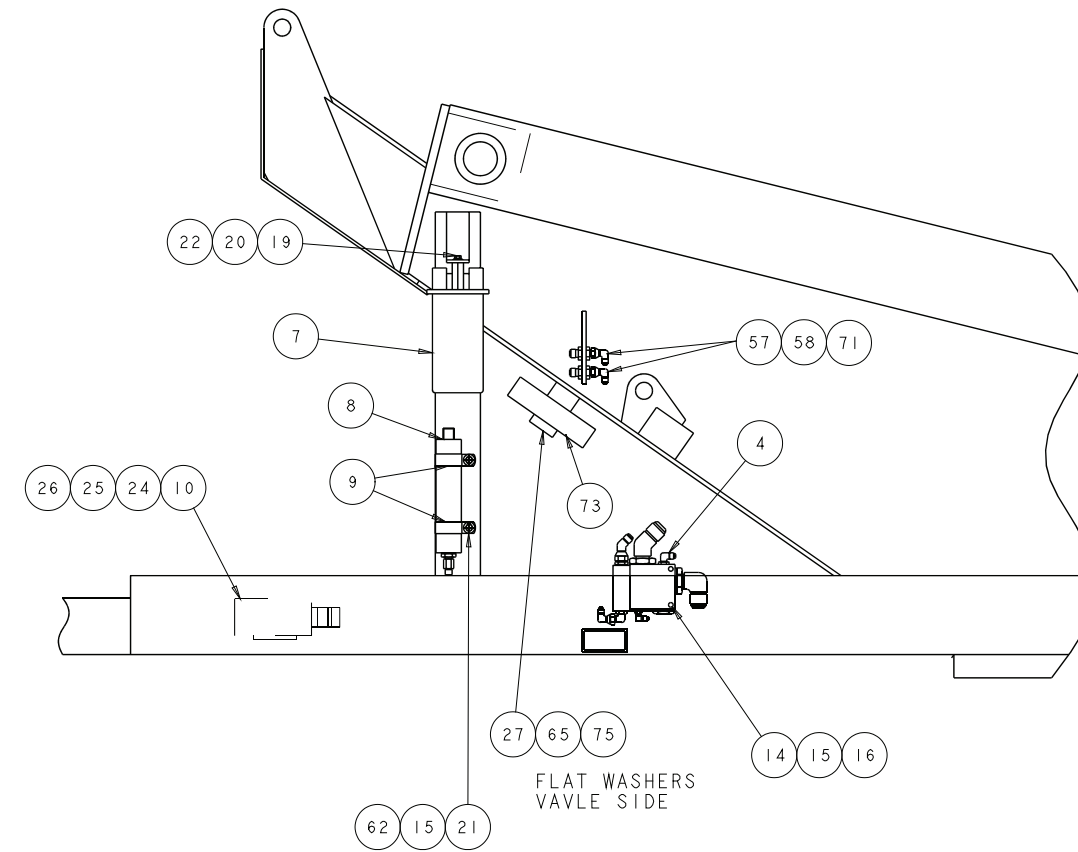
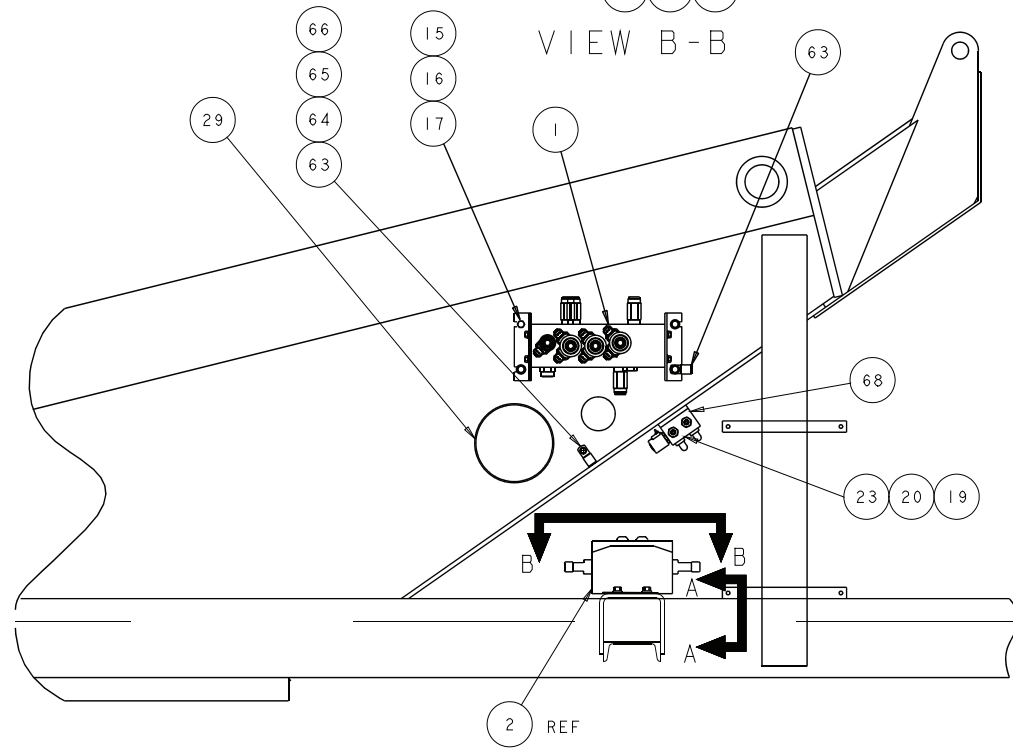

SECTIONAL VIEW A-A

F  
E  
D  
C  
B  
A

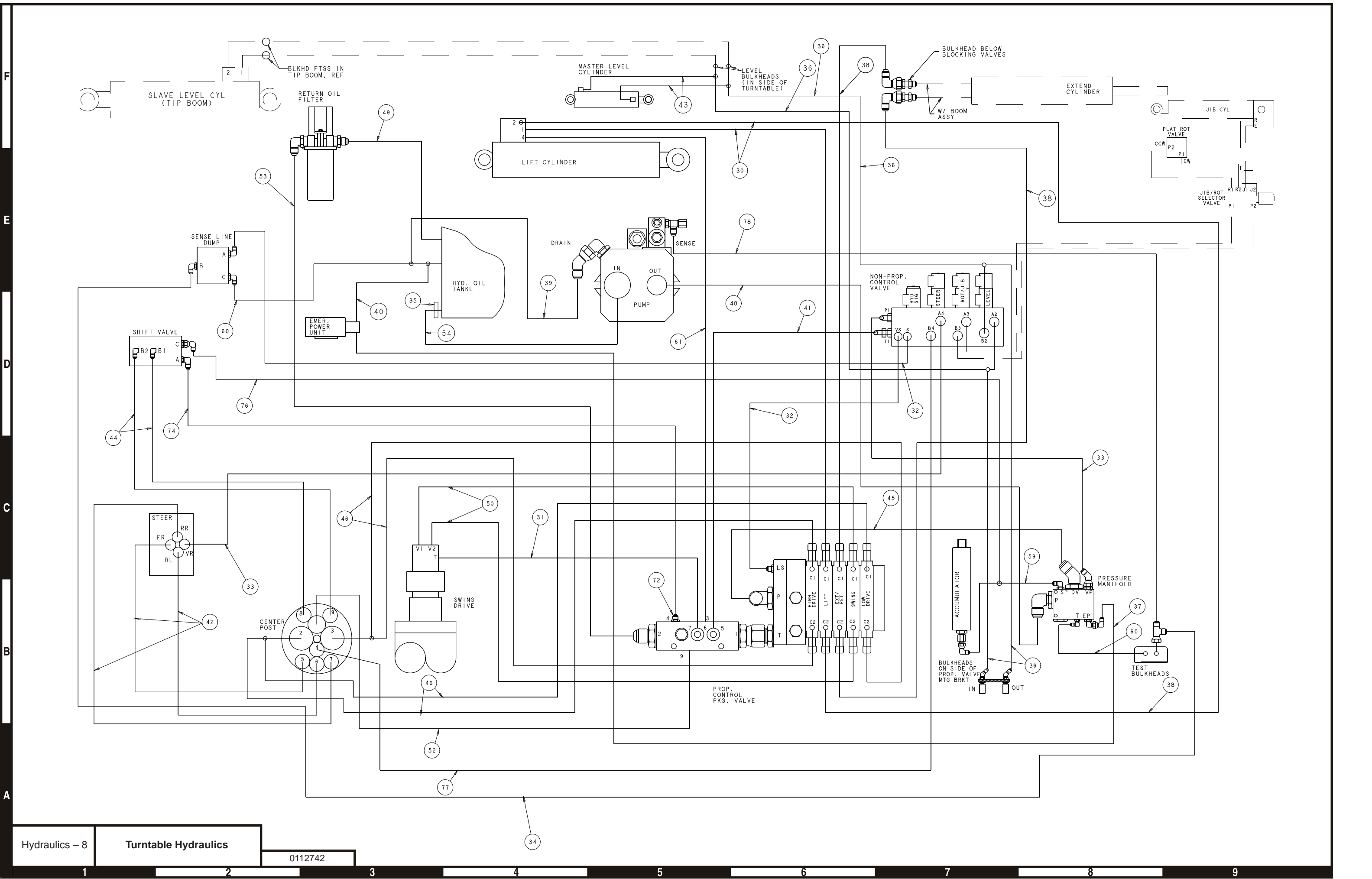

## Turntable Hydraulics

Item	Part No.	Qty.	Description
1	0112759	1	NON PROPORTIONAL VALVE SUB ASSY
2	0111857	1	PROPORTIONAL CONTROL VALVE SUB ASSY
4	0111879	1	PRESS MANIFOLD VALVE SUB ASSY
7	0112029	1	RETURN FILTER SUB ASSY
8	0082055	1	ACCUMULATOR SUB ASSY
9	5093014	2	CLAMP
10	0072940	1	EMERGENCY POWER UNIT SUB ASSY
11	5034601	2	FTG ELB45BHD-4S-4S STL
12	5074401	6	LOCKNUT (-4)
13	5070006	4	NIPPLE DIAGNOSTIC
14	970569	2	CAPSCREW, 3/8-16 X 3-1/2 LG HH GR5
15	986299	14	WASHER, 3/8 FLAT
16	987119	12	WASHER, 3/8 MEDIUM LOCK
17	970449	4	CAPSCREW, 3/8-13 X 3/4 LG HH GR5
18	970239	2	CAPSCREW, 5/16-18 X 3/4 LG HH GR5
19	986269	8	WASHER, 5/16 FLAT
20	987109	8	WASHER, 5/16 MEDIUM LOCK
21	970479	6	CAPSCREW, 3/8-16 X 1-1/4 LG HH GR5
22	970239	1	CAPSCREW, 5/16-18 X 3/4 LG HH GR5
23	970319	7	CAPSCREW, 5/16-18 X 2-1/2 LG HH GR5
24	970709	4	CAPSCREW, 7/16-14 X 1 LG HH GR5
25	986179	4	WASHER, 7/16 FLAT
26	987129	4	WASHER, 7/16 MEDIUM LOCK
27	970069	2	BOLT HEXHD .25-20 1.25
28	5035403	2	BULKHEAD RUN TEE (-4/-4)
29	5560277	2 FT	3/8 TRIM-LOK
30	0080522	2	HOSE-8-8S-8S 42 100R2
31	0070771	1	HOSE-4-4S-4S 77 100R1
32	0020280	2	HOSE-4-4S-4S 23.5 100R2
33	0020273	2	HOSE-6-6S-6S 35.5 100R2
34	0020283	1	HOSE-4-4S-4S 15.25 100R1
35	5058820	1	CLAMP, SUCTION HOSE
36	0050137	5	HOSE-4-4S-4S 36 100R1
37	0050400	1	HOSE-6-6S-6S 41 100R2
38	0060315	2	HOSE-8-8S-8S 48 100R2
39	0070927	1	HOSE-8-8S-8S 23.5 100R2
40	0070792	1	HOSE-8-8S-8S 32 100R2
41	0070789	1	HOSE-6-6S-6S 19 100R2
42	0080362	3	HOSE-6-6S-6S 93.5 100R2
43	0080359	2	HOSE-4-4S-4S 23.5 100R1
44	0100271	2	HOSE-4-4S-4S 103 100R1
45	0111843	1	HOSE-16-16S-16S 24.5
46	0111844	4	HOSE-10-10S-10S 86
48		1	3/4 ID HOSE ASSY
49	0180943	1	HOSE-20-20S-20S 25.5
50	0180784	2	HOSE-8-8S-8S 72
52	0110198	1	HOSE-8-8S-8S 96 100R2
53	0111882	1	HOSE-20-20S-20S 64.5
54	0111883	1	1-1/2 ID SUCTION HOSE
55	5034401	1	BULKHEAD UNION
56	5034501	1	BULKHEAD ELBOW 90° ELBOW (-4)
57	5034404	2	BULKHEAD UNION (-8)
58	5074404	2	LOCKNUT, BULKHEAD (-8)
59	0040276	1	HOSE -4-4S-4S 20.5 100R1
60	0070765	2	HOSE -4-4S-4S 29 100R1
61	0060297	1	HOSE-4-6S-6S 28 100R2
62	5560003	2	NUT HEX .375-16 LKG
63	5093000	2	CLAMP
64	970029	1	CAPSCREW 1/4-20 .75 GR5 HH

## Turntable Hydraulics

## Turntable Hydraulics

Item	Part No.	Qty.	Description
65	986019	2	WASHER FLAT .250
66	987099	1	WASHER LOCK .250 MDM
67	5036903	2	FTG ELB45SWVL-4S-4S
68	0112829	1	SHIFT SPEED VALVE SUB ASSY
69	0112703	1	ASSY, SENSE LINE DUMP
70	5036703	1	FTG TEE SWVL -4S-4S STL
71	5037006	2	FTG ELB90SWVL-8S-8S STL
72	5065705	1	FTG ADPTR STRTHD -6S-4S STL
73	0112826	1	VALVE 4 WHEEL STEER SUB ASSY
74	0070776	1	HOSE 4-6S-6S 19.5 100R1
75	5560004	2	NUT .25-20 ESNA
76	0020281	1	HOSE 4-4S-4S 27.63 100R1
77	0111286	1	HOSE 4-6S-6S 84 100R2
78	0040276	1	HOSE 4-4S-4S 20.5 100R1
79	0075378	1	DECAL, SYSTEM PRESSURE
80	0075379	1	DECAL, LEVER RELIEF PRESSURE
81	0075380	1	DECAL, SENSE PRESSURE

## Turntable Hydraulics



## Hydraulic Oil Reservoir

Item	Part No.	Qty.	Description
1	0110364	1	HYDR OIL RESERVOIR
2	3080018	1	FILTER SUMP STRAINER
3	5037305	1	CONNECTOR 2" STRAIGHT
4	7714204	1	FTG PLUG .50 NPT BLK SQ. HEAD
5	5090007	1	GAUGE LIQUID LEVEL W/THERM
6	5090008	1	FILTER/BREATHER CAP ASSY
7	0110367	1	COVER PLATE
8	0110368	1	COVER PLATE GASKET
9	5560691	6	SCRW HEXHD #10-24 .500 PLTD
10	5560654	6	WSHR LOCK MDM 10
11	970369	10	BLT HEXHD .313-18 1.00 GR5
12	987109	10	WSHR LOCK .313
13	5033623	1	FTG ADPTR MALE-20N-20S STL
14	7734204	1	STREET TEE-1/2 NPT STREET TEE
15	5033713	1	FTG ELB90 MALE-8N-8S STL-PH 21
16	5033614	1	FTG ADPTR MALE-8N-8S STL-2404-
17	5036706	2	FTG TEE SWVL RUN-8S-8S STL
18	5063906	1	FTG NUT-8S STL
19	5064002	1	FTG RDCR-8S-4S W/O NUT STL
21	7721612	1	REDUCER BUSHING-2X1-1/2 HEX HD
22	5037011	1	FTG ELB90SWVL-20S-20S STL-PH 2

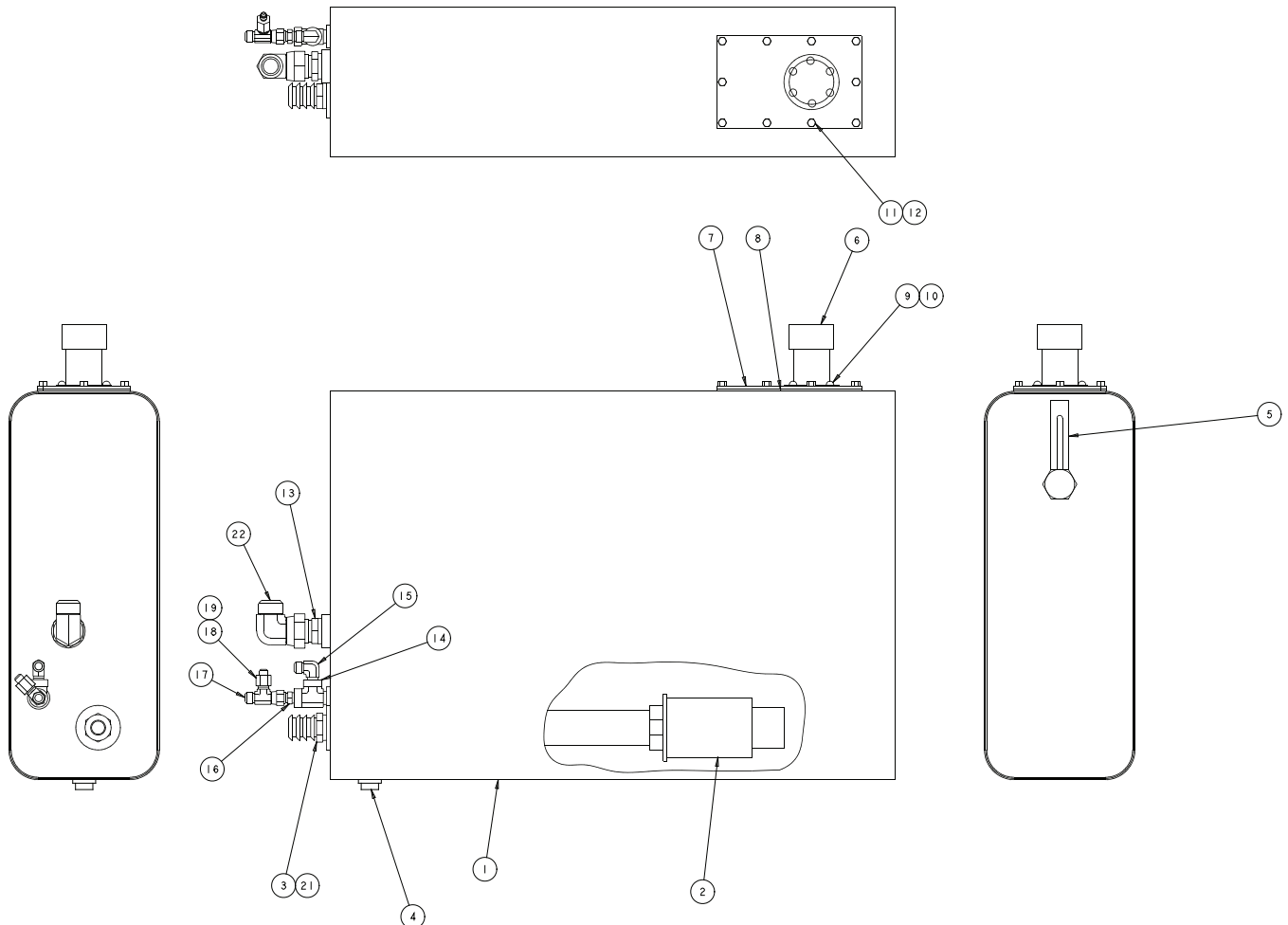

0110360

## Hydraulic Oil Reservoir



# Proportional Control Valve

Item	Part No.	Qty.	Description
1	6010846	1	PROPORTIONAL CONTROL VALVE
2	5065709	5	FTG ADPTRSTRTHD-8B-8S STL
3	5065703	1	FTG ADPTRSTRTHD-4B-4S STL
4	5068324	1	FTG ELB90STRTHD-16B-20S STL
5	5035306	1	FTG ELB90STRTHD-8B-8S STL
6	5035311	1	FTG ELB90STRTHD-12B-16S STL
7	5025002	1	FTG ADPTRSWVL-16B-16S STL
8	5065729	4	FTG APDTRSWVL-16B-16S STL
9	5037006	2	FTG ELB90SWVL-8S-8S STL
10	5075208	1	FTG PL HEX HD-12B STL
11	5065806	1	FTG ADPTRSTRTHD L-8B-8S STL
12	0110156	1	PRESSURE MANIFOLD
13	5075205	2	FTG PL HEXHD-6B STL
14	5075206	1	FTG PL HEXHD-8B STL
16	5065705	1	FTG ADPTRSTRTHD-6B-4S STL
17	5036903	1	FTG ELB45SWVL-4S-4S STL
18	5065719	1	FTG ADPTRSTRTHD-12B-16S STL
19	5037003	1	FTG ELB90SWVL-4S-4S STL
20	5036906	2	FTG ELB45SWVL-8S-8S STL
21	5035305	1	FTG ELB90STRTHD-6S-6S STL
22	5035705	1	FTG ELB45STRTHD-6B-6S STL

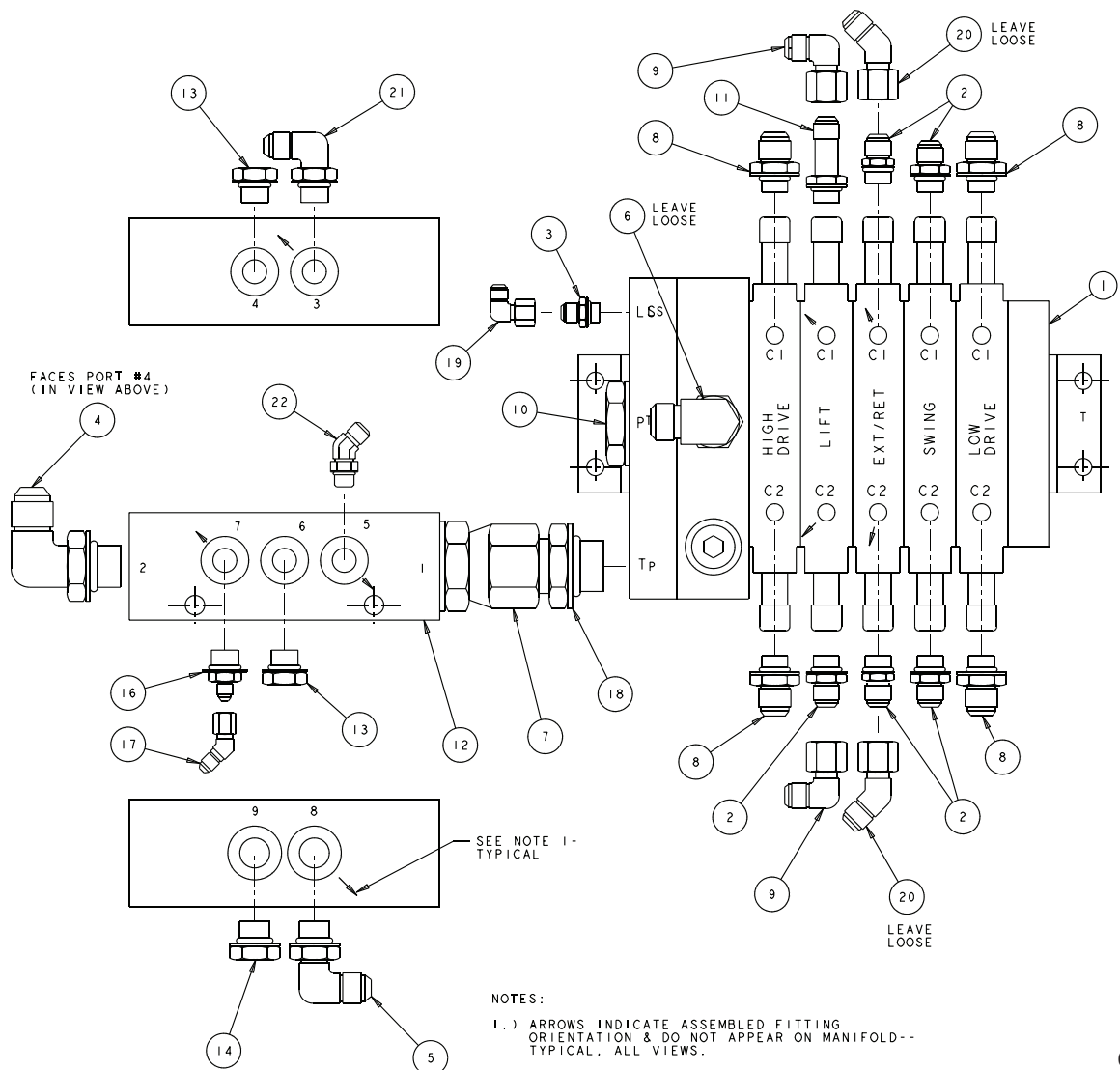

# Proportional Control Valve

0111857



# Proportional Control Valve

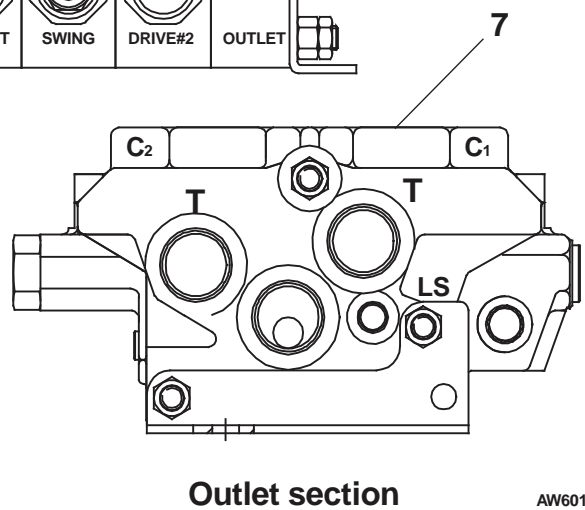
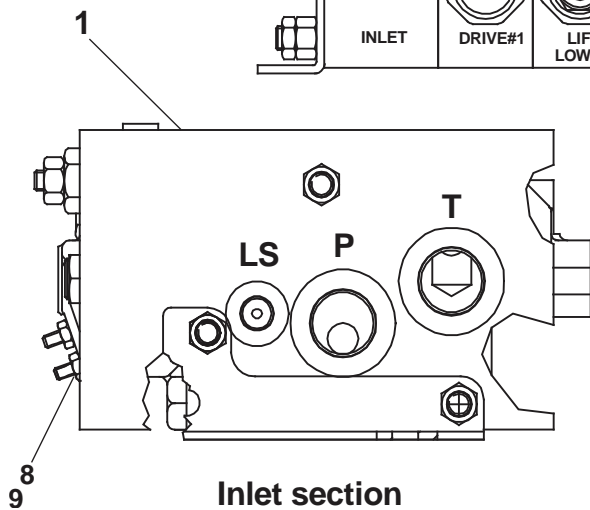
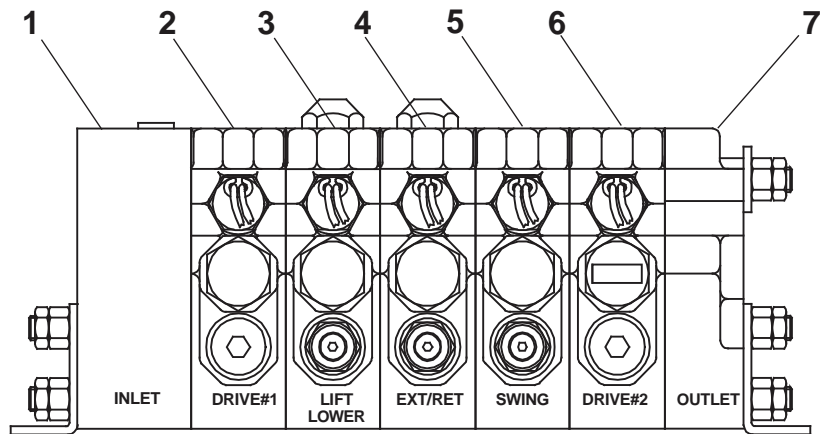
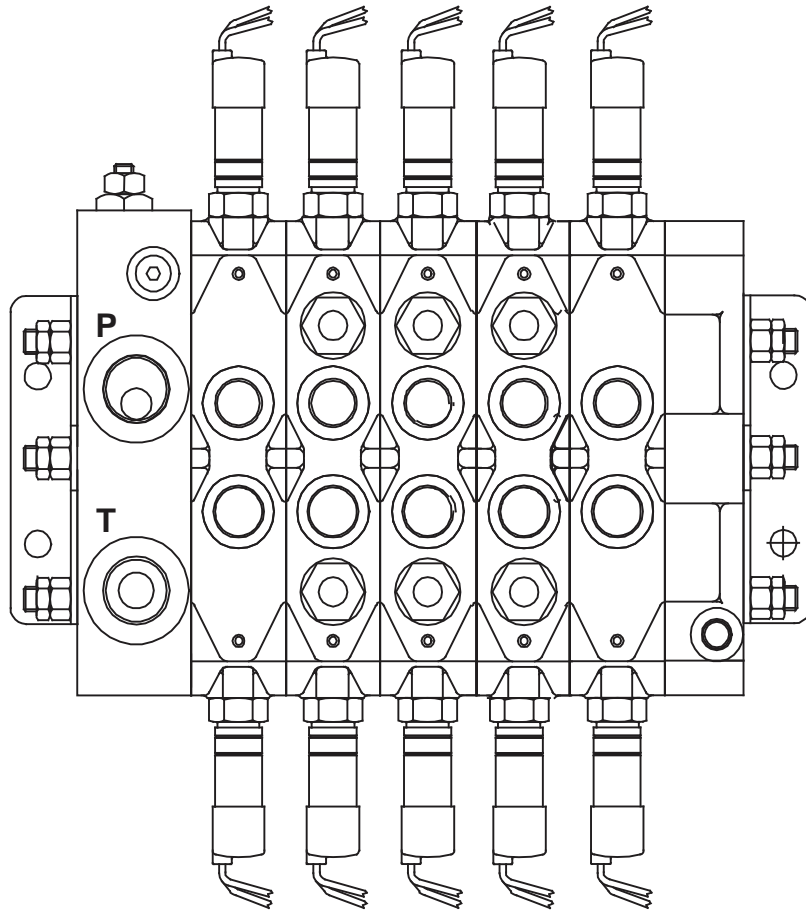

Inlet section

Outlet section

# Proportional Control Valve

AW6010846

## Proportional Control Valve

Item	Part No.	Qty.	Description
1	6010846	1	Control valve, proportional
	6010860	1	Inlet section
	8010245	1	O-ring seal kit for valve section
2	6010890	1	Drive control valve section #1
	8010245	1	O-ring seal kit for valve section
	6010653	2	Solenoid cartridge, 12 volt DC - (black - 33 Hz) (includes cartridge, o-ring and orifice disc - must be installed as complete unit)
3	6010891	1	Lift/lower control valve section
	8010245	1	O-ring seal kit for valve section
	6010653	2	Solenoid cartridge, 12 volt DC - (black - 33 Hz) (includes cartridge, o-ring and orifice disc - must be installed as complete unit)
4	6010892	1	Extend/retract control valve section
	8010245	1	O-ring seal kit for valve section
	6010845	2	Solenoid cartridge, 12 volt DC - (blue - 60 Hz) (includes cartridge, o-ring and orifice disc - must be installed as complete unit)
5	6010893	1	Swing control valve section
	8010245	1	O-ring seal kit for valve section
	6010653	2	Solenoid cartridge, 12 volt DC - (black - 33 Hz) (includes cartridge, o-ring and orifice disc - must be installed as complete unit)
6	6010894	1	Drive control valve section #2
	8010245	1	O-ring seal kit for valve section
	6010653	2	Solenoid cartridge, 12 volt DC - (black - 33 Hz) (includes cartridge, o-ring and orifice disc - must be installed as complete unit)
7	6010871	1	Outlet section
	8010245	1	O-ring seal kit for valve section
8	8010273	2	Nut/washer
9	8010274	2	Set screw

0111857

## Proportional Control Valve

## Non-Proportional Control Valve

Item	Part No.	Qty.	Description
1	6019060	1	NON PROPORTIONAL VALVE
2	0191640	2	ANGLE
3	0082010	1	DECAL SET
4	0192127	1	ADAPTOR HARNESS, NON PROPORTIONAL VALVE
5	5075205	2	FTG PL HEXHD-6B
6	5037005	1	FTG EBL90SWVL-6S-6S
7	5035320	1	FTG ELB90STRTHD-8B-8S
8	5065703	2	FTG ADAPTER STRTHD-4B-4S
9	5065805	6	FTG ADAPTER STRTHD LG-6B-6S
10	5063905	4	FTG NUT -6S
11	5064001	4	FTG RDCRTUBE -6S-4S
12	5036703	2	FTG TEESWVLRUN -4S-4S
13	5065708	1	FTG ADAPTER STRTHD-8S-6S
14	970239	4	BOLT HEXHD .313-18 X .75
15	987109	4	WASHER LOCK .313

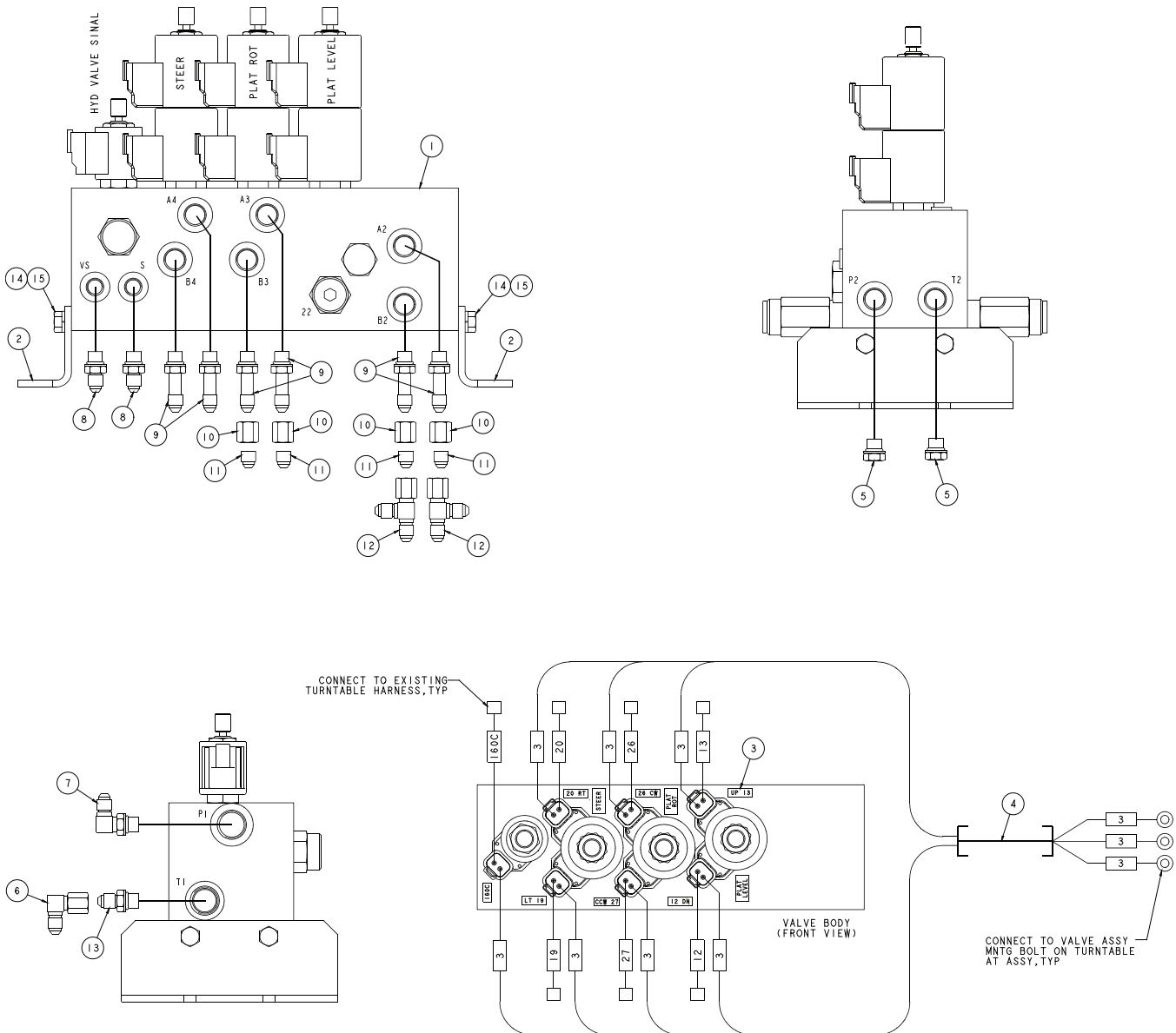

0112759

## Non-Proportional Control Valve





## Non-Proportional Control Valve

Item	Part No.	Qty.	Description
1	487086	1	FLOW CONTROL VALVE
2	6019153	1	SOLENOID VALVE
3	6019154	1	SOLENOID VALVE
4	6019041	1	SHUTTLE VALVE
5		1	SOLENOID VALVE
6		2	SOLENOID VALVE
7		8	COIL
8		1	RELIEF VALVE
9		1	RELIEF VALVE
10		1	RELIEF VALVE
11		1	RELIEF VALVE
12		1	DOUBLE PO CHECK
13		21	PERM PLUG
14		7	FLUSH HEAD PLUG
15		1	ORIFICE .035
16		1	VALVE BODY
17		1	ORIFICE .070

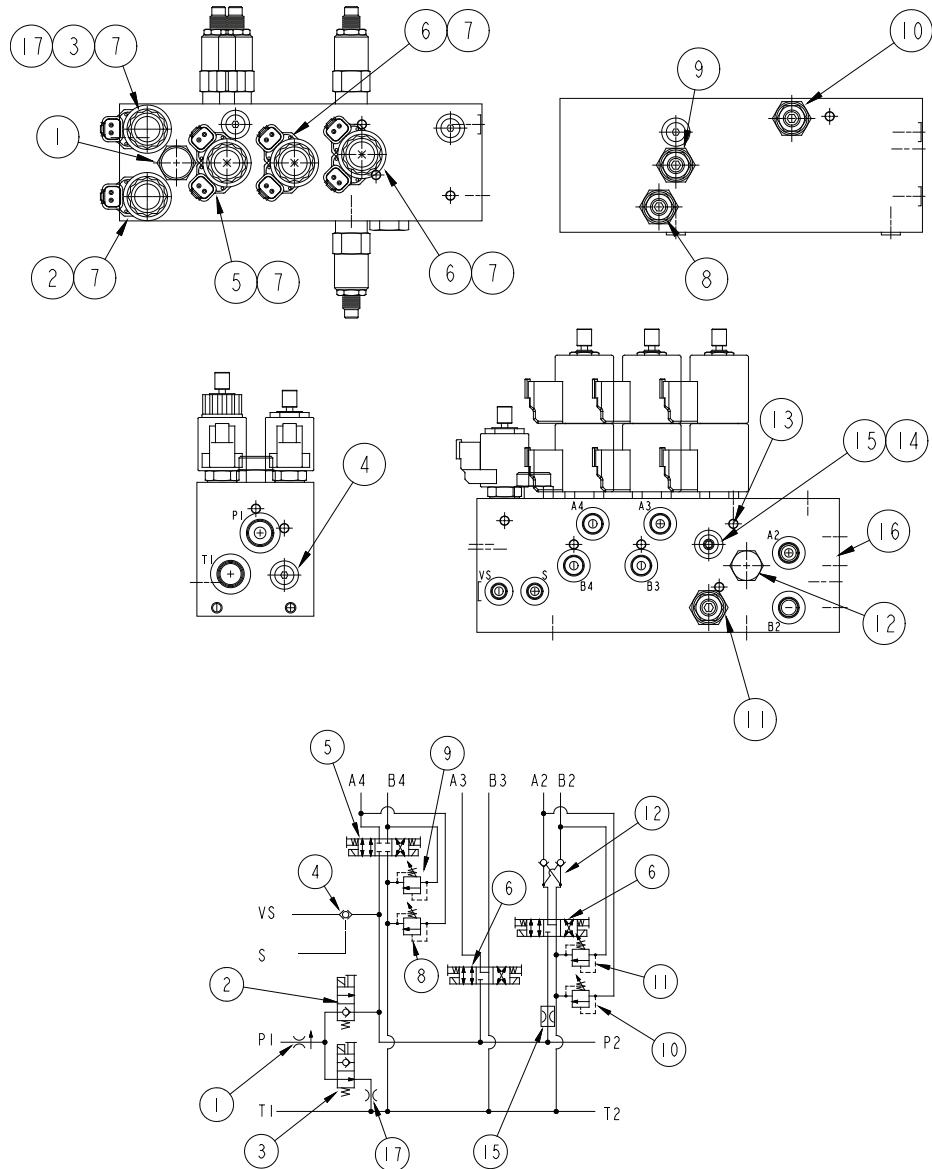

HYDRAULIC SCHEMATIC

## Non-Proportional Control Valve

6019141



## AC Generator Valve

Item	Part No.	Qty.	Description
	015283128	1	AC GENERATOR VALVE
1	6010489	1	AC GENERATOR VALVE - (INCLUDES ITEMS 2, 3 AND 4 - VALVE IS NOT PRESET)
2	6010508	1	CARTRIDGE VALVE WITH COIL
	6010509	1	REPLACEMENT CARTRIDGE VALVE WITHOUT COIL
	3040457	1	REPLACEMENT COIL, 12 VOLT DC
3	6018901	1	FLOW CONTROL VALVE CARTRIDGE
4	6010510	1	SHUTTLE VALVE CARTRIDGE
5	5065803	2	LONG STRAIGHT THREAD ADAPTER
6	5037003	2	SWIVEL NUT 90° ELBOW
7	5035306	1	STRAIGHT THREAD 90° ELBOW
8	5035320	1	STRAIGHT THREAD 90° ELBOW

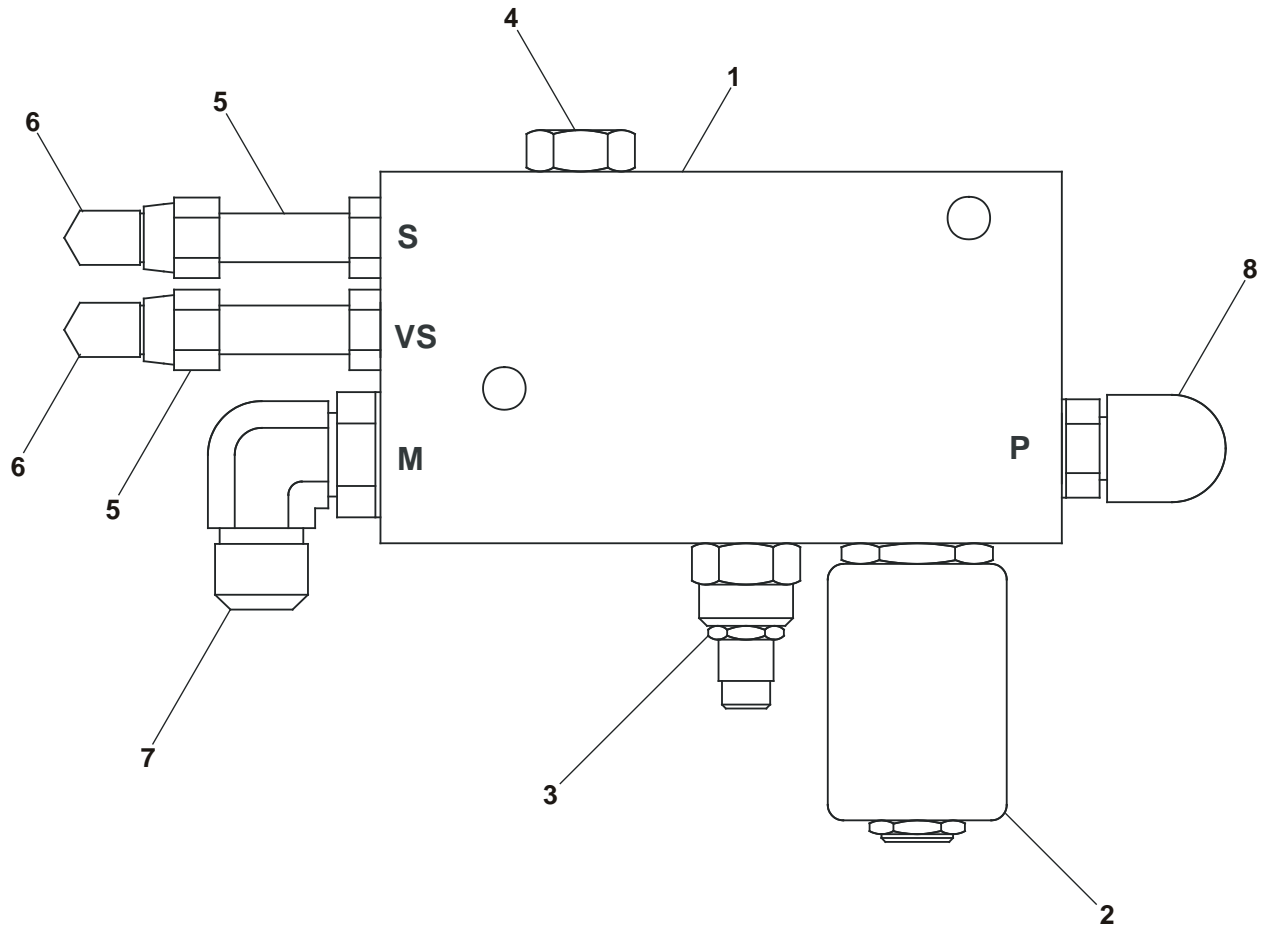

AW0152831

## AC Generator Valve



# Centerpost

Item	Part No.	Qty.	Description
1	0112718	1	CENTERPOST SUPPORT
	0112978	1	SEAL KIT
2	970919	2	BOLT .500-13 1.75 GR5
3	5035305	4	FTG ELB90STRTHD-6B-6S STL
4	5035310	2	FTG ELB90STRTHD-16B-16S STL
5	5035321	1	FTG ELB90STRTHD-4B-6S STL
6	5036503	1	FTG TEE STRTHD BR-4B-4S STL
7	5036707	2	FTG TEESWVL RUB -10S-10S STL
8	5036806	1	FTG TEE SWVL BR-8S-8S STL
9	5037003	2	FTG ELB90SWVL-4S-4S STL
10	5037007	2	FTG ELB90SWVL-10S-10S STL
11	5065703	2	FTG ADPTRSTRTHD-4B-4S STL
12	5065707	4	FTG ADPRTSTRTHD-6B-6S STL
13	5065709	1	FTG ADPTRSTRTHD-8B-8S STL
14	5065710	1	FTG ADPTRSTRTHD-10B-8S STL
15	5067012	2	FTG ADPTRSTRTHD-16B-10S STL
16	5560039	2	NUT LKG .500-13
17	7714203	2	PIPE PLUG, 3/8 NPT SQ HD BLK

PORT	DESCRIPTION	PORT SIZE		HOSE SIZE	
		SPOOL	HOUSING	SPOOL	HOUSING
1	DRAIN/RETURN	-8	-10	-8	-6
2	DRIVE-REV	-16	-16	-16	-10
3	DRIVE-FWD	-16	-16	-16	-10
4	STEER FL	-6	-6	-6	-6
5	STEER FR	-6	-6	-6	-6
6	STEER RL	-6	-6	-6	-6
7	STEER RR	-6	-6	-6	-6
8	PILOT 2WD/4WD	-4	-4	-4	-4
9	PILOT HI/LOW	-4	-4	-4	-6

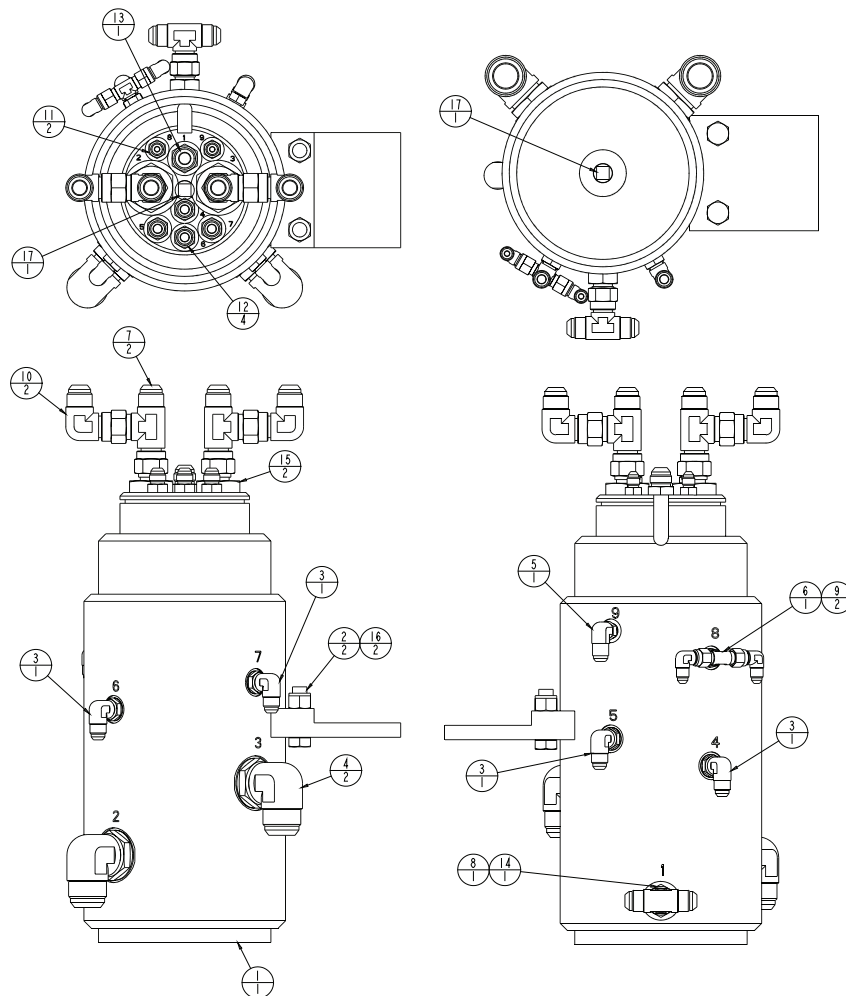

0112747

# Centerpost



## Cylinder, Extension – GBI

Item	Part No.	Qty.	Description
	0110623	1	CYLINDER, EXTENSION - GBI
	8070380	1	SEAL REPAIR KIT - (KIT INCLUDES ITEMS 13 THROUGH 24)
1		1	TUBE - (NOT SOLD SEPARATELY)
2	8070373	1	ROD
3	8070231	1	THREAD RING
4	8070374	1	HEAD GLAND
5	8070375	1	PISTON
6	8070376	1	SPACER
7	8070363	1	CAPSCREW
8	8070362	1	LOCK WASHER
9	8070377	1	NUT
10	8070378	1	RETAINING RING
11	8070379	1	RETAINING RING
12	8070368	1	PORT PLUG
13	KIT ITEM	1	O-RING - (NOT SOLD SEPARATELY)
14	KIT ITEM	1	NYLON PLUG - (NOT SOLD SEPARATELY)
15	KIT ITEM	1	BACK-UP - (NOT SOLD SEPARATELY)
16	KIT ITEM	1	O-RING - (NOT SOLD SEPARATELY)
17	KIT ITEM	1	TEFLON SEAL - (NOT SOLD SEPARATELY)
18	KIT ITEM	2	WEAR RING - (NOT SOLD SEPARATELY)
19	KIT ITEM	1	O-RING - (NOT SOLD SEPARATELY)
20	KIT ITEM	2	WEAR RING - (NOT SOLD SEPARATELY)
21	KIT ITEM	1	U-CUP - (NOT SOLD SEPARATELY)
22	KIT ITEM	1	BACK-UP - (NOT SOLD SEPARATELY)
23	KIT ITEM	1	WEAR RING - (NOT SOLD SEPARATELY)
24	KIT ITEM	1	WIPER, AN - (NOT SOLD SEPARATELY)
25	6010116	1	CARTRIDGE HOLDING VALVE - (PRESET BY FACTORY, DO NOT RESET)
	0071918	1	SEAL REPAIR KIT

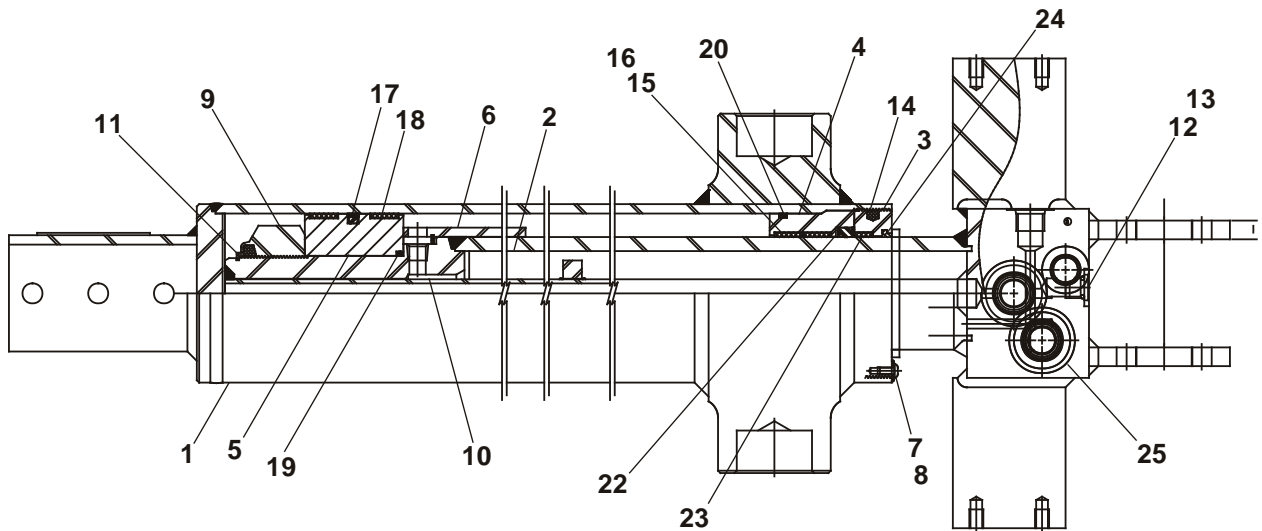

AWV00226

## Cylinder, Extension – GBI





## Cylinder, Lift

Item	Part No.	Qty.	Description
1	0110168	1	LIFT CYLINDER
1	0112380	1	CYLINDER, LIFT
2	5065707	1	STRAIGHT THREAD ADAPTER
3	5065709	2	STRAIGHT THREAD ADAPTER

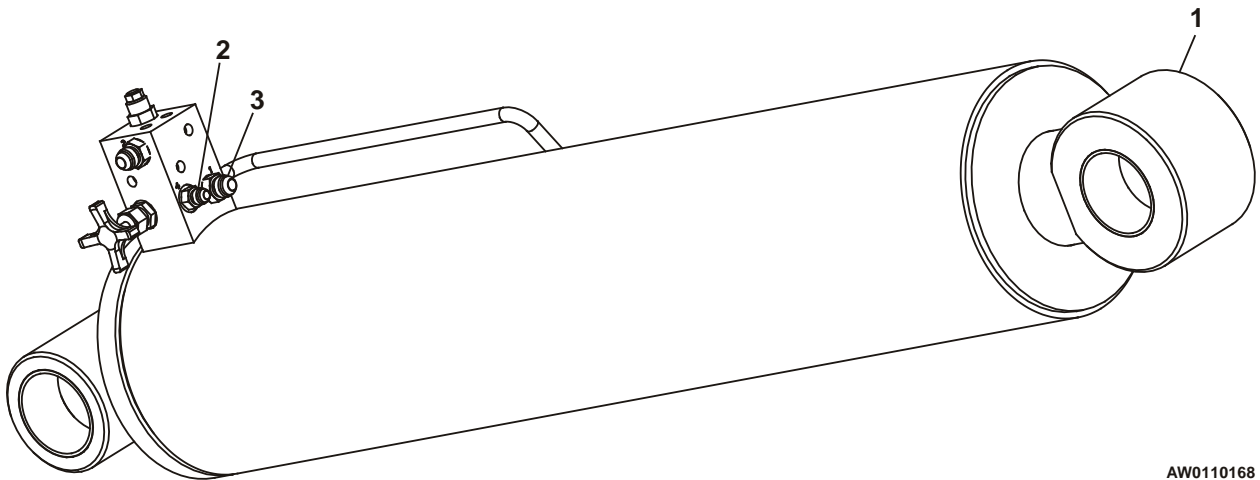

## Cylinder, Lift



## Cylinder, Lift – Rosenboom

Item	Part No.	Qty.	Description
	0112380	1	CYLINDER, LIFT - ROSENBOOM
	6091362	1	SEAL REPAIR KIT - (KIT INCLUDES ITEMS 12 THROUGH 22)
1		1	TUBE - (NOT SOLD SEPARATELY)
2	6091361	1	ROD
3	6091359	1	HEAD GLAND
4	6091358	1	PISTON
5	6091241	1	POPPET
6	6091246	1	SPRING
7	6091314	1	COUNTERBALANCE HOLDING VALVE - (PRESET BY FACTORY, DO NOT RESET)
8	6010115	1	CARTRIDGE NEEDLE VALVE
	0071845	1	SEAL REPAIR KIT
9	975839	4	SET SCREW 3/8-16 X 3/4 INCH LONG HEX SOCKET HEAD
10	5075306	1	HEX PLUG
11	2500063	4	BEARING
12	KIT ITEM	1	O-RING - (NOT SOLD SEPARATELY)
13	KIT ITEM	1	O-RING - (NOT SOLD SEPARATELY)
14	KIT ITEM	1	O-RING - (NOT SOLD SEPARATELY)
15	KIT ITEM	1	BACK-UP - (NOT SOLD SEPARATELY)
16	KIT ITEM	1	DEEP Z-SEAL - (NOT SOLD SEPARATELY)
17	KIT ITEM	1	CAST IRON RING - (NOT SOLD SEPARATELY)
18	KIT ITEM	1	CAPPED T-SEAL - (NOT SOLD SEPARATELY)
19	KIT ITEM	1	ROD WIPER - (NOT SOLD SEPARATELY)
20	KIT ITEM	2	WEARBAND - (NOT SOLD SEPARATELY)
21	KIT ITEM	2	WEARBAND - (NOT SOLD SEPARATELY)
22	KIT ITEM	2	LOCKING INSERT - (NOT SOLD SEPARATELY)

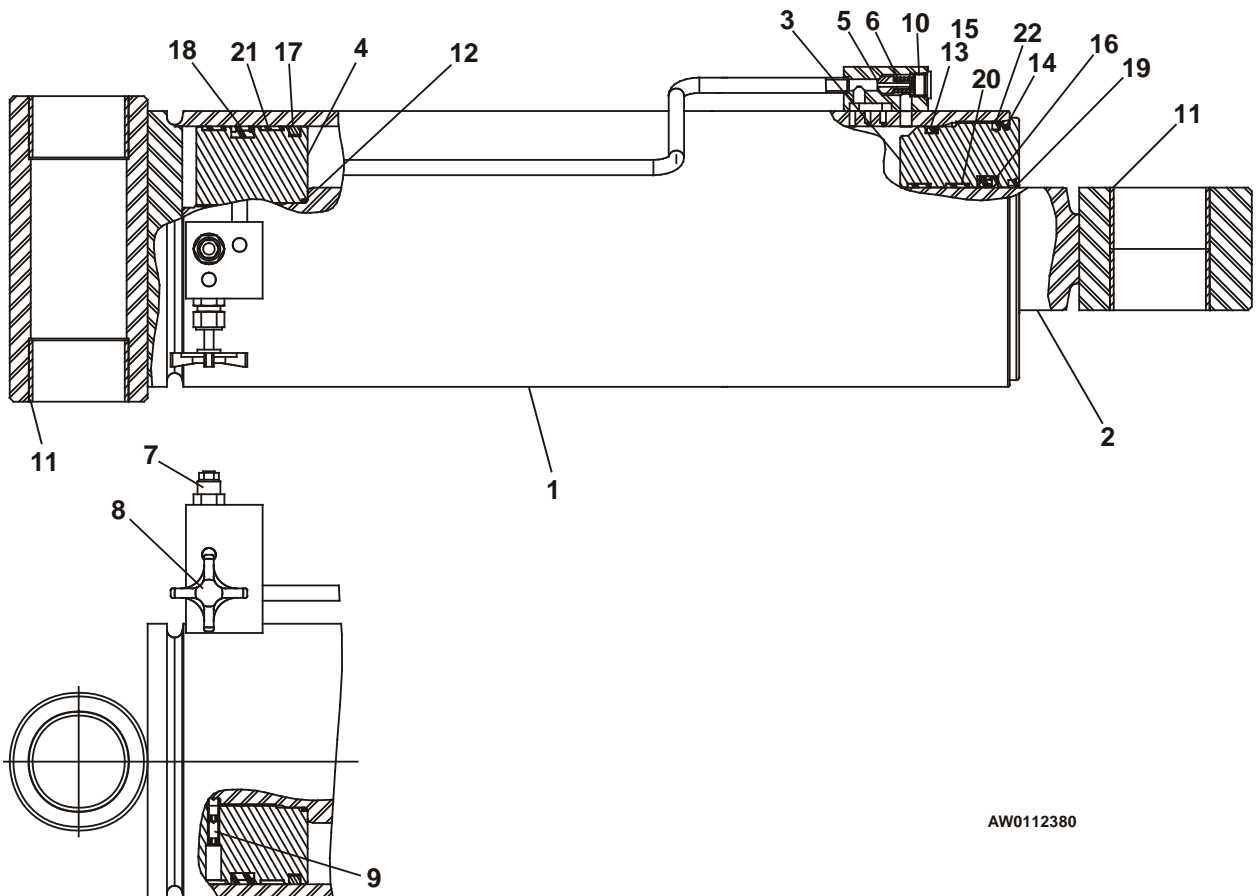

AW0112380

## Cylinder, Lift – Rosenboom



## Cylinder, Master Level

Item	Part No.	Qty.	Description
	0172223	1	CYLINDER
	8071007	1	SEAL KIT
1	KIT ITEM	1	WEAR RING - (NOT SOLD SEPARATELY)
2	KIT ITEM	1	PISTON SEAL - (NOT SOLD SEPARATELY)
3	KIT ITEM	1	O-RING - (NOT SOLD SEPARATELY)
4	KIT ITEM	1	O-RING - (NOT SOLD SEPARATELY)
5	KIT ITEM	1	BACKUP RING - (NOT SOLD SEPARATELY)
6	KIT TIEM	1	ROD WIPER - (NOT SOLD SEPARATELY)
7	KIT TIEM	1	ROD SEAL - (NOT SOLD SEPARATELY)

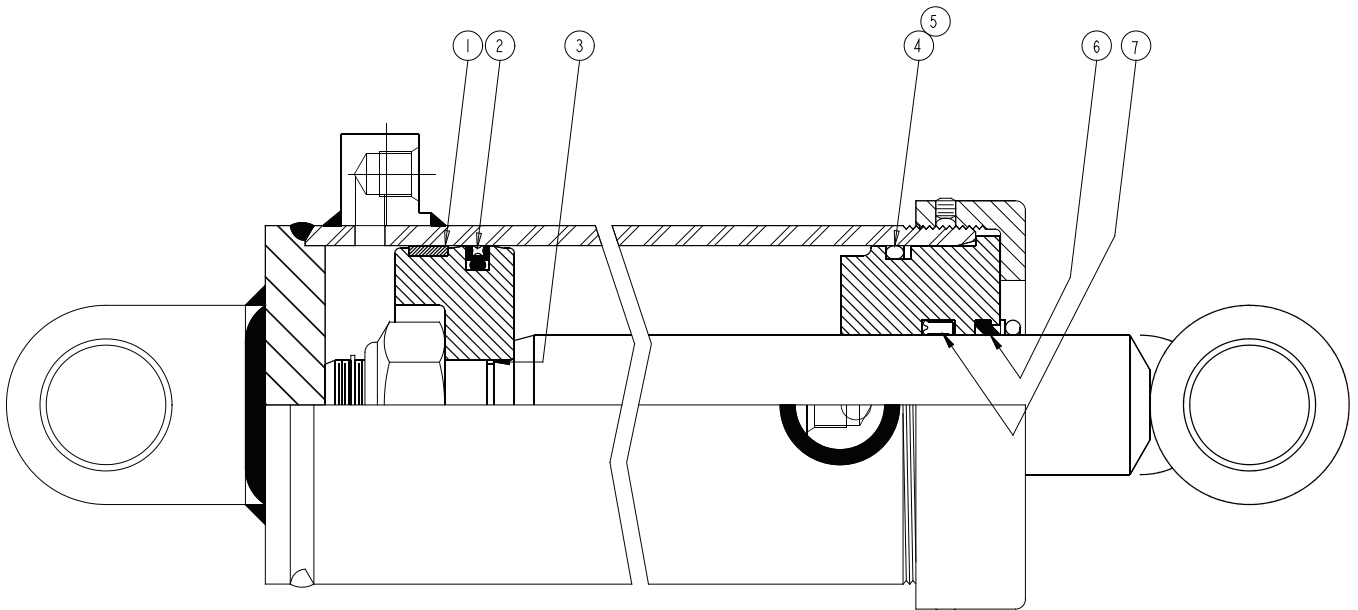

0172223

## Cylinder, Master Level



## Cylinder, Slave Level TB80

Item	Part No.	Qty.	Description
	0074713	1	CYLINDER, SLAVE LEVEL - ROSENBOOM
	6091260	1	SEAL REPAIR KIT - (KIT INCLUDES ITEMS 10 THROUGH 19)
1		1	CYLINDER TUBE - (NOT SOLD SEPARATELY)
2	6091258	1	ROD
3	6091255	1	HEAD GLAND CAP
4	6091257	1	HEAD GLAND
5	6091256	1	PISTON
6	6091259	1	LOCK NUT
7	5569835	1	SET SCREW 5/16-18 X 1/4 INCH LONG
8	2502416	4	BUSHING
9	6010794	2	CARTRIDGE HOLDING VALVE - (FACTORY PRESET, DO NOT RESET)
	0150563	1	SEAL REPAIR KIT
10	KIT ITEM	1	EXTERNAL SNAP RING - (NOT SOLD SEPARATELY)
11	KIT ITEM	1	O-RING - (NOT SOLD SEPARATELY)
12	KIT ITEM	1	O-RING - (NOT SOLD SEPARATELY)
13	KIT ITEM	1	BACK-UP RING - (NOT SOLD SEPARATELY)
14	KIT ITEM	1	T-SEAL - (NOT SOLD SEPARATELY)
15	KIT ITEM	1	DEEP Z-SEAL - (NOT SOLD SEPARATELY)
16	KIT ITEM	1	ROD WIPER - (NOT SOLD SEPARATELY)
17	KIT ITEM	1	WEARBAND - (NOT SOLD SEPARATELY)
18	KIT ITEM	2	WEARBAND - (NOT SOLD SEPARATELY)
19	KIT ITEM	1	LOCKING INSERT - (NOT SOLD SEPARATELY)

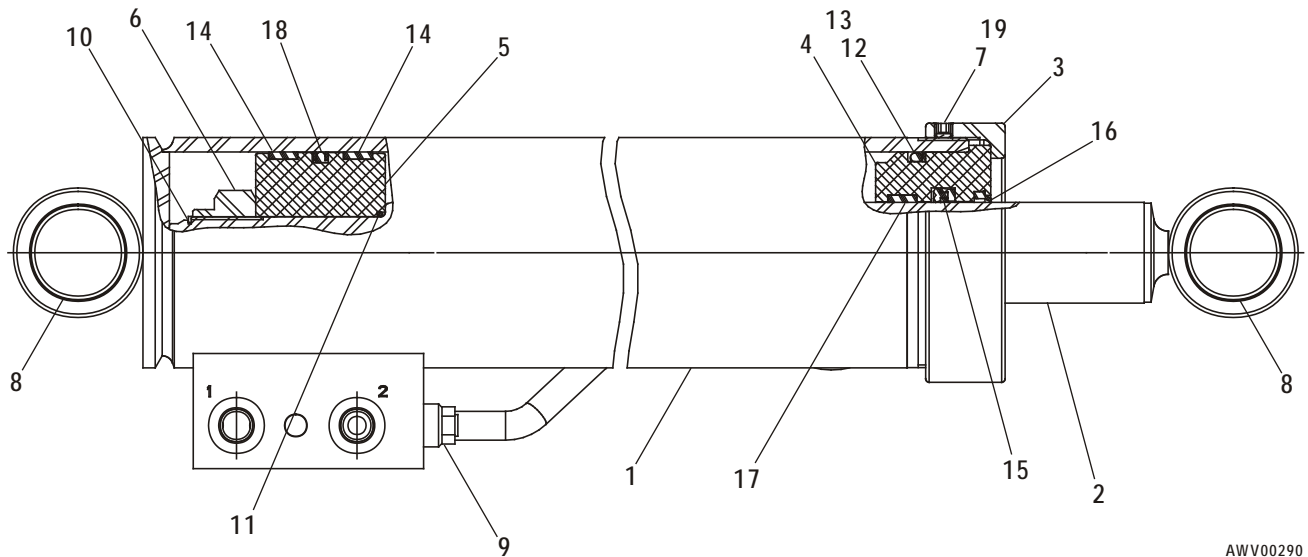

AWV00290

## Cylinder, Slave Level TB80





## Cylinder, Slave Level TB85J

Item	Part No.	Qty.	Description
	0172224	1	CYLINDER, SLAVE LEVEL – GREEN
	8071007	1	SEAL KIT - INCLUDES ITEMS BELOW NOT SHOWN
	KIT ITEM	1	WEAR RING
	KIT ITEM	1	PISTON SEAL (AQ)
	KIT ITEM	1	O-RING
	KIT ITEM	1	O-RING
	KIT ITEM	1	BACKUP
	KIT ITEM	1	ROD WIPER
	KIT ITEM	1	ROD SEAL
	5035318	2	FTG ELB 90 STRTHD-6B-4S STL-PH4
1	6019068	2	CARTRIDGE, COUNTERBALANCE

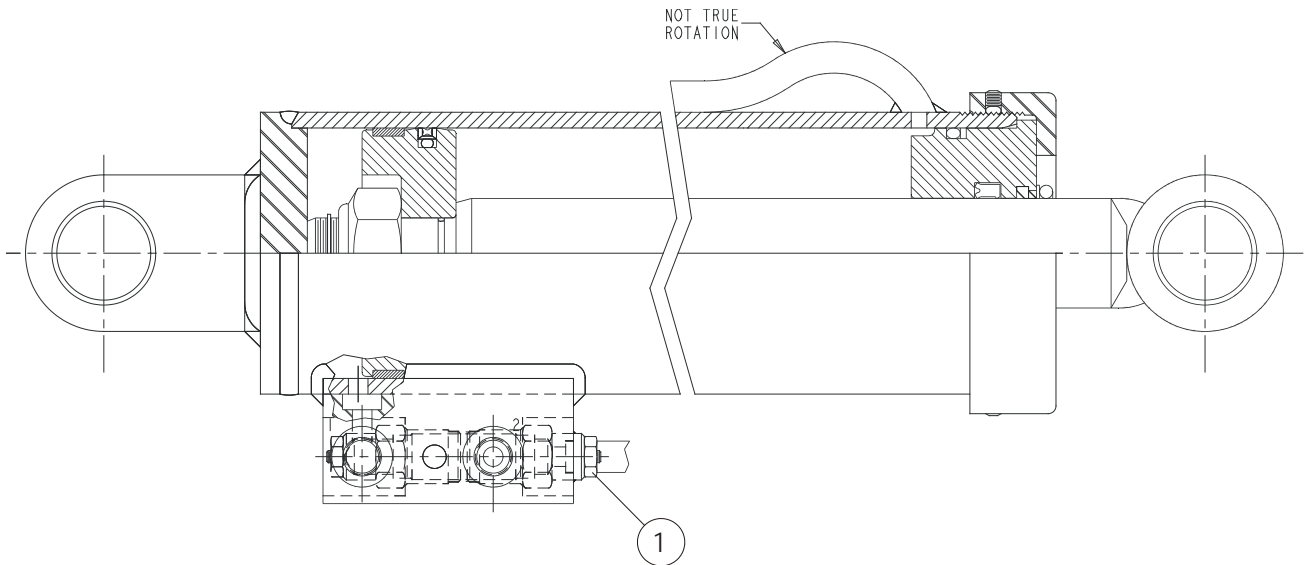

0172224 C

## Cylinder, Slave Level TB85J



## Cylinder, Steering

Item	Part No.	Qty.	Description
	0112777	1	CYLINDER, STEERING
1	6091534	1	GLAND
2	6091536	1	PISTON
3	6091556	1	ROD ASSEMBLY
4	6091557	1	BARREL ASSEMBLY
	6091538	1	REPAIR KIT - INCLUDES ITEMS 5-11 AND 16
5	KIT ITEM	1	O-RING - (NOT SOLD SEPARATELY)
6	KIT ITEM	1	O-RING - (NOT SOLD SEPARATELY)
7	KIT ITEM	1	ROD SEAL - (NOT SOLD SEPARATELY)
8	KIT ITEM	1	BACKUP RING - (NOT SOLD SEPARATELY)
9	KIT ITEM	1	ROD WIPER - (NOT SOLD SEPARATELY)
10	KIT ITEM	1	WEAR-RING - (NOT SOLD SEPARATELY)
11	KIT ITEM	2	WEAR-RING - (NOT SOLD SEPARATELY)
12	6091539	1	SNAP RING
13		2	PLUG
14		1	SET SCREW
15	6091540	1	NUT, COLLAR FULL
16	KIT ITEM	1	PISTON SEAL - (NOT SOLD SEPARATELY)
17		2	BLEEDER VALVE
18	2509699	4	BEARING
19		1	O-RING

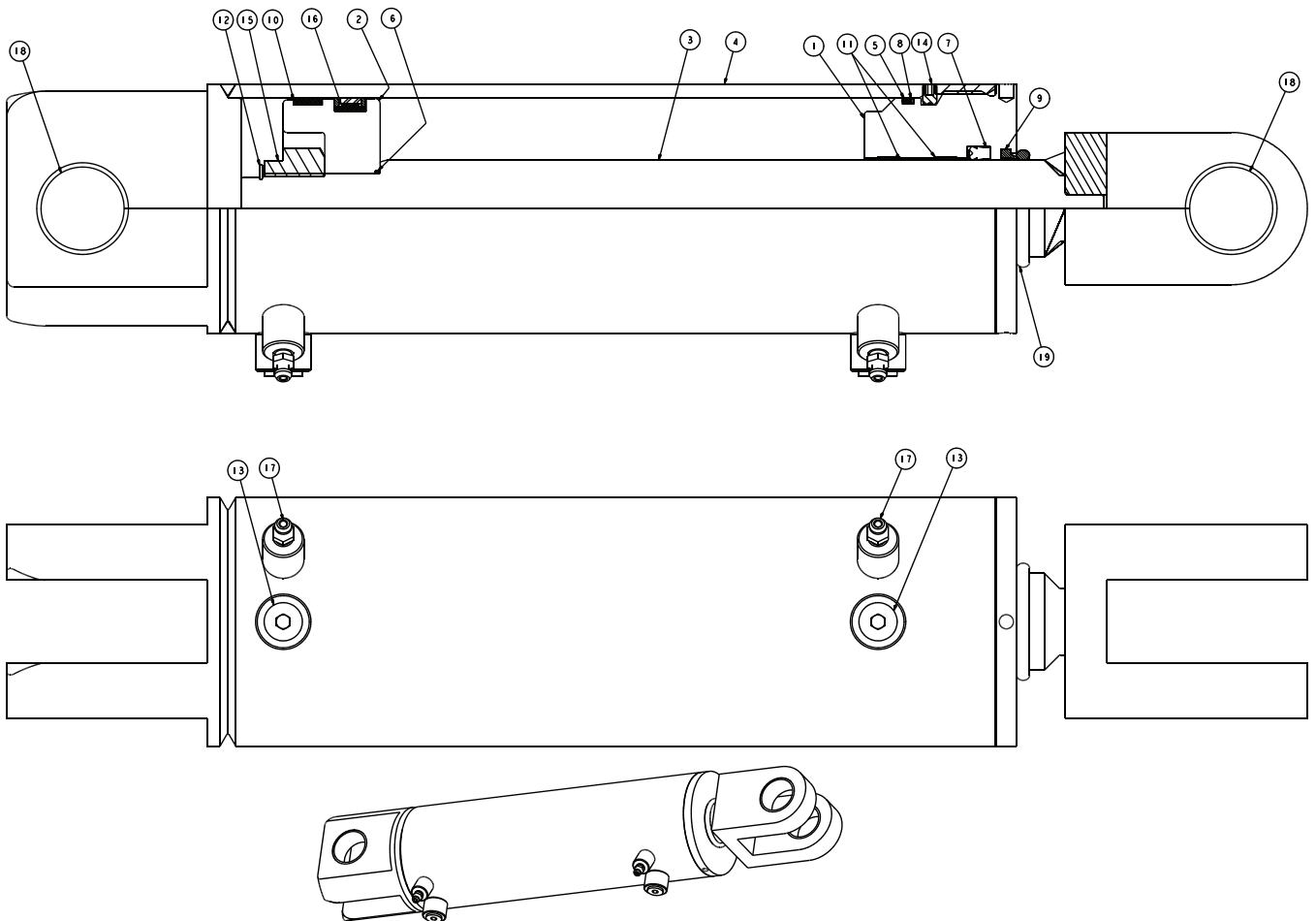

0112777

## Cylinder, Steering



## Cylinder, Jib – TB85J

Item	Part No.	Qty.	Description
	6047114	1	JIB CYLINDER
	8071006	1	SEAL KIT
1	KIT ITEM	1	PISTON SEAL - (NOT SOLD SEPARATELY)
2	KIT ITEM	1	O-RING - (NOT SOLD SEPARATELY)
3	KIT ITEM	1	O-RING - (NOT SOLD SEPARATELY)
4	KIT ITEM	1	BACKUP RING - (NOT SOLD SEPARATELY)
5	KIT ITEM	1	ROD WIPER - (NOT SOLD SEPARATELY)
6	KIT ITEM	1	ROD SEAL - (NOT SOLD SEPARATELY)
7	6010606	2	CARTRIDGE COUNTERBALANCE

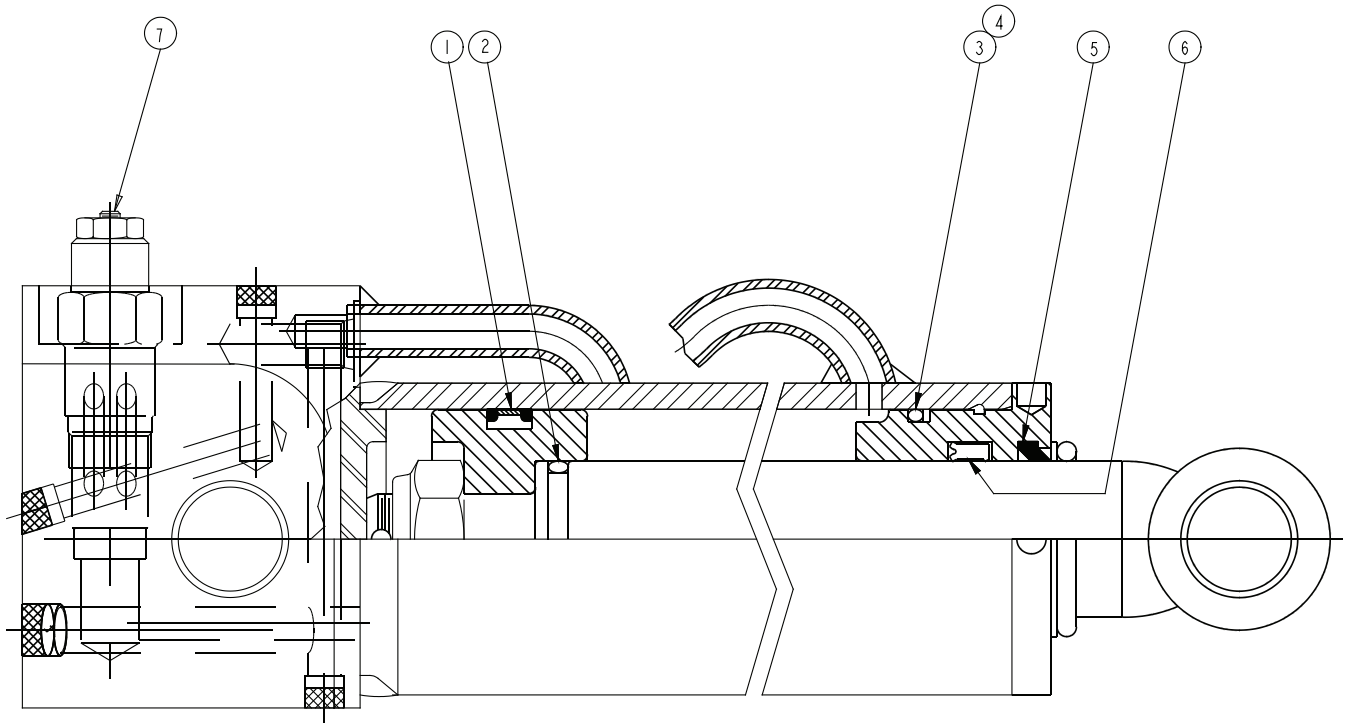

6047114

## Cylinder, Jib – TB85J



## Emergency Power Unit

Item	Part No.	Qty.	Description
1	0072940	1	EMERGENCY POWER UNIT
	6020058	1	EMERGENCY POWER MOTOR/PUMP
	8060296	1	PUMP
	8060297	1	MOTOR
	459986	1	COUPLING
2	5037006	1	SWIVEL NUT 90° ELBOW
3	5035305	1	STRAIGHT THREAD 90° ELBOW
4	5065709	1	STRAIGHT THREAD ADAPTER

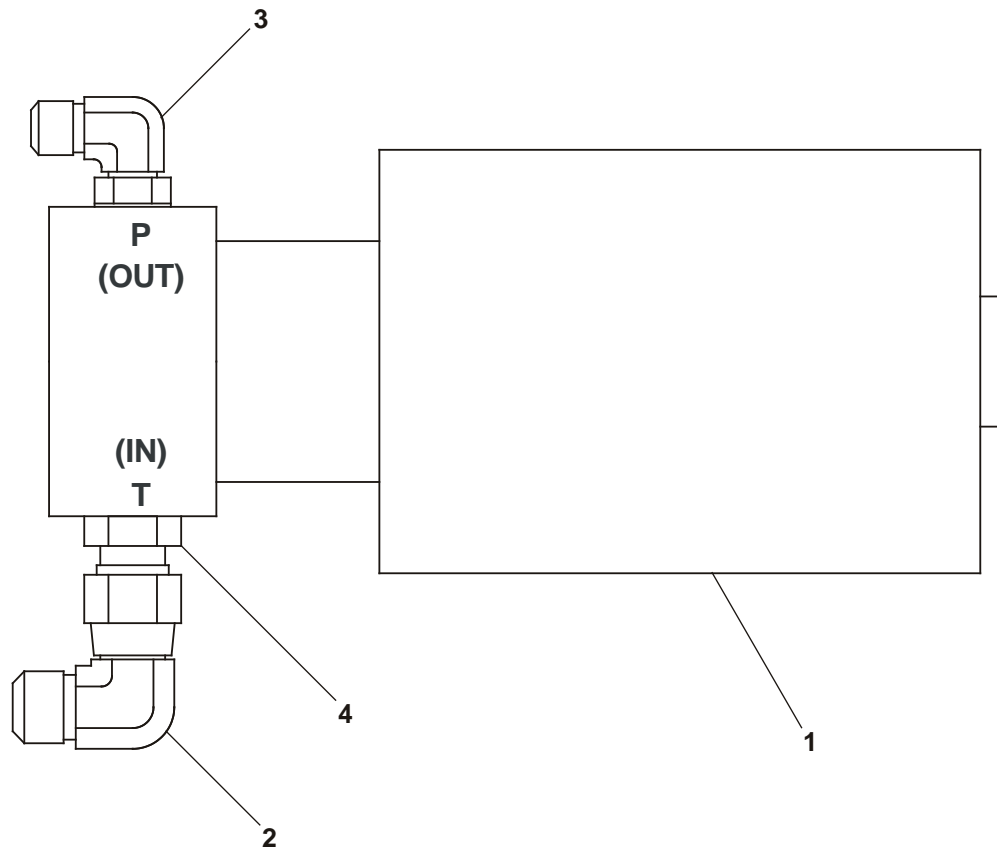

AW0072940

## Emergency Power Unit





## Hydraulic Pump and Fittings

Item	Part No.	Qty.	Description
1	0111578	1	HYDRAULIC PUMP - (COMPLETE)
	6020065-99	1	HYDRAULIC PUMP - (PUMP COMPENSATOR IS NOT PRESET)
	8220119	1	SEAL REPAIR KIT
	8220120	1	REPLACEMENT COMPENSATOR
2	5038005	1	BEADED 90° ELBOW
3	5065718	1	STRAIGHT THREAD ADAPTER
4	5036906	1	SWIVEL NUT 45° ELBOW
7	5065710	1	STRAIGHT THREAD ADAPTER
8	5035303	1	STRAIGHT THREAD 90° ELBOW
9	5037006	1	SWIVEL NUT 90° ELBOW

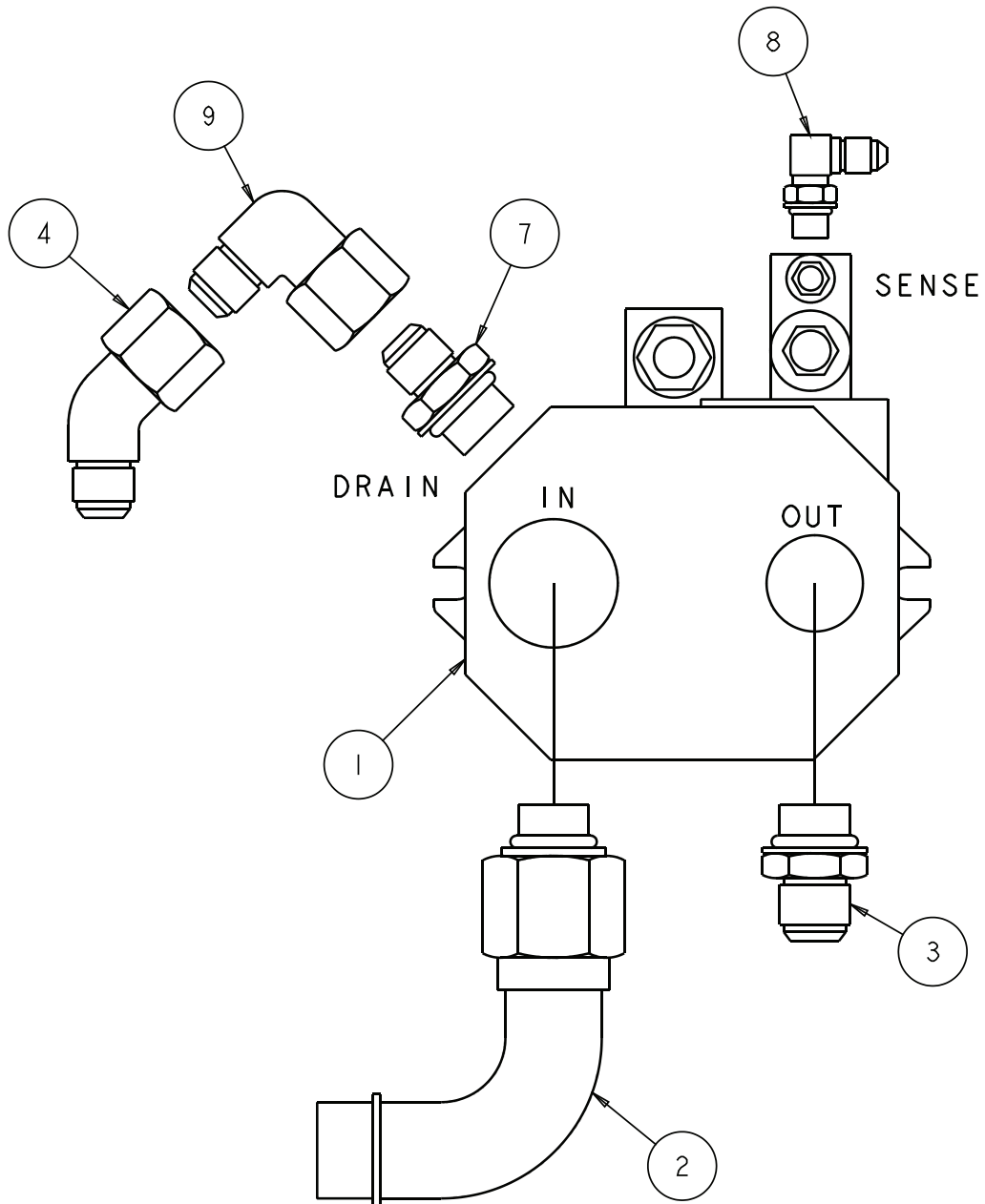

0111578

## Hydraulic Pump and Fittings



## Sense Line Dump Valve

Item	Part No.	Qty.	Description
1	0074765	1	BRKT SENSE LINE DUMP VLV
2	969989	2	BOLT .25-20 1.75
3	986019	2	WASHER FLAT .250
4	5035318	2	FTG ELB90STRTHD-6B-4S
5	5037003	1	FTG ELB90SWVL-4S-4S STL
6	5065705	1	FTG ADPTR STRTHD-6B-4S STL
7	5560004	2	NUT HEX LKG .250-20
8	6010499	1	VALVE ASSY 3WAY 10 VOLT SINGLE

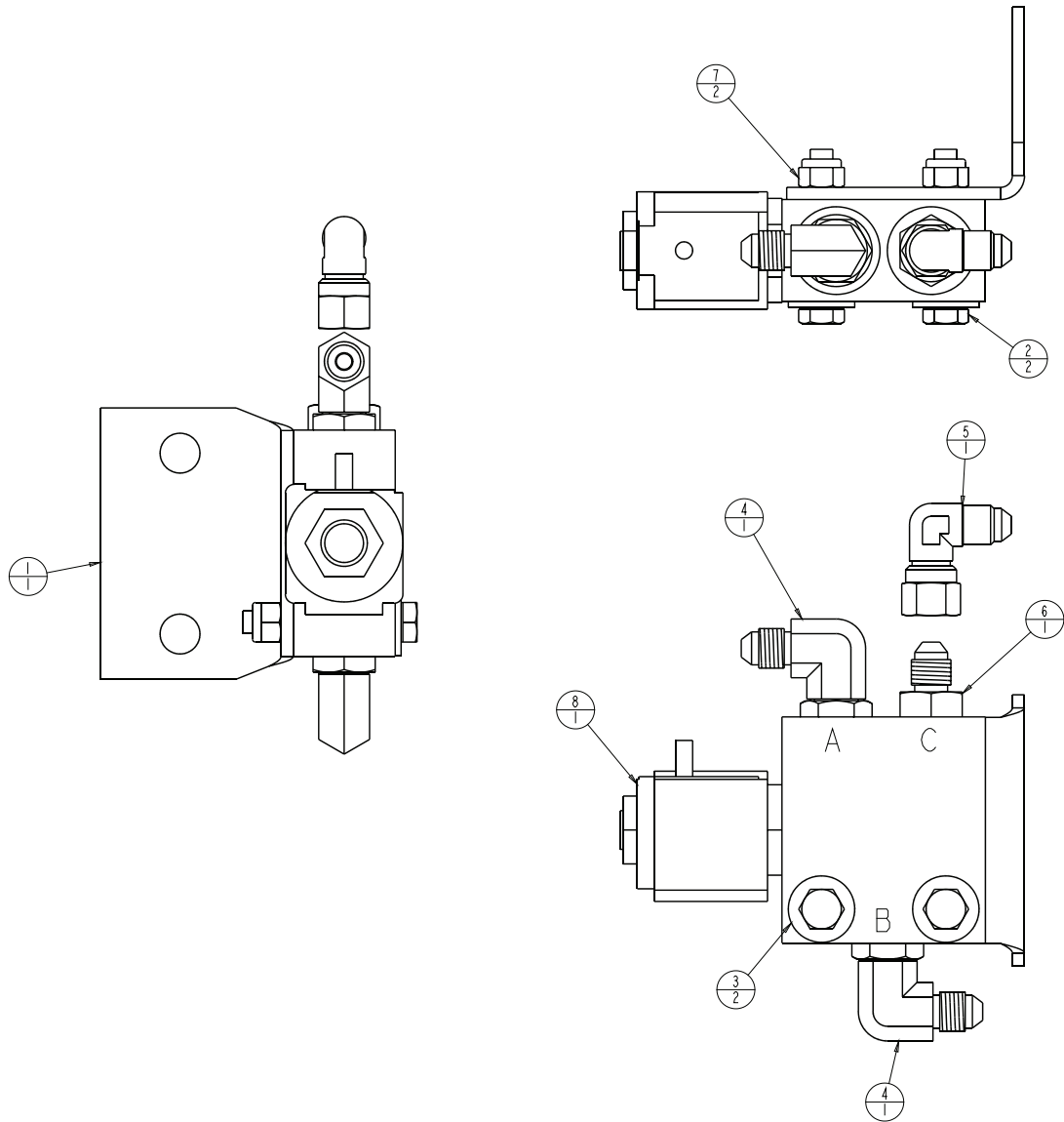

0112703

## Sense Line Dump Valve



## Hydraulic Warm-Up Valve

Item	Part No.	Qty.	Description
1	0073072	1	HYDRAULIC WARM-UP VALVE
	6010499	1	SOLENOID VALVE
	0073620	1	SEAL REPAIR KIT
	6010472	1	REPLACEMENT CARTRIDGE
	3040473	1	REPLACEMENT SOLENOID, 10 VOLT DC
2	6010083	1	SHUTTLE VALVE
3	5065705	2	STRAIGHT THREAD ADAPTER
4	5035318	2	STRAIGHT THREAD 90° ELBOW
5	5076301	1	UNION
6	5037003	1	SWIVEL NUT 90° ELBOW

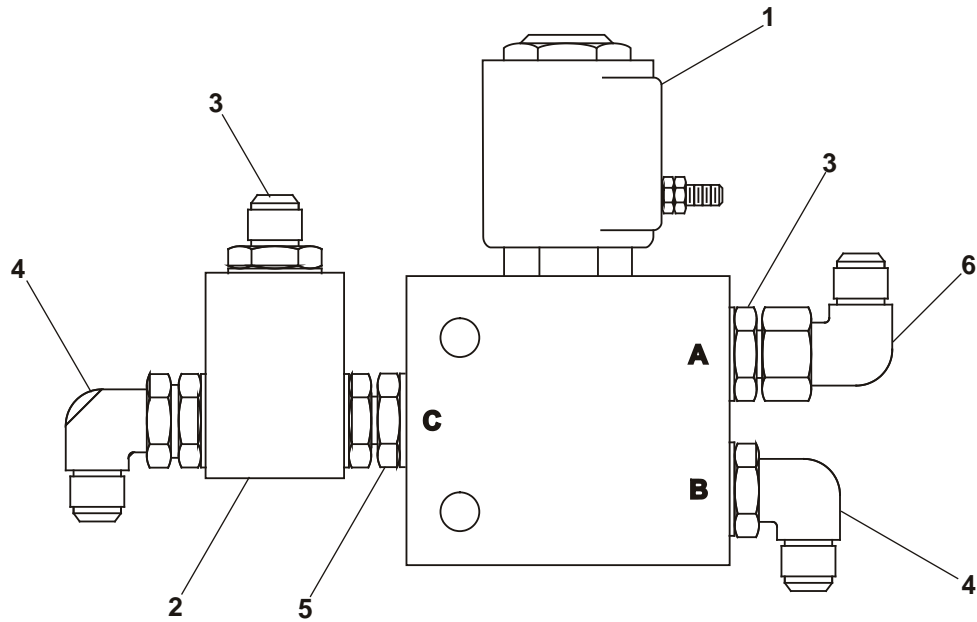

AW0073072

## Hydraulic Warm-Up Valve



# Motion Control Valve, Drive

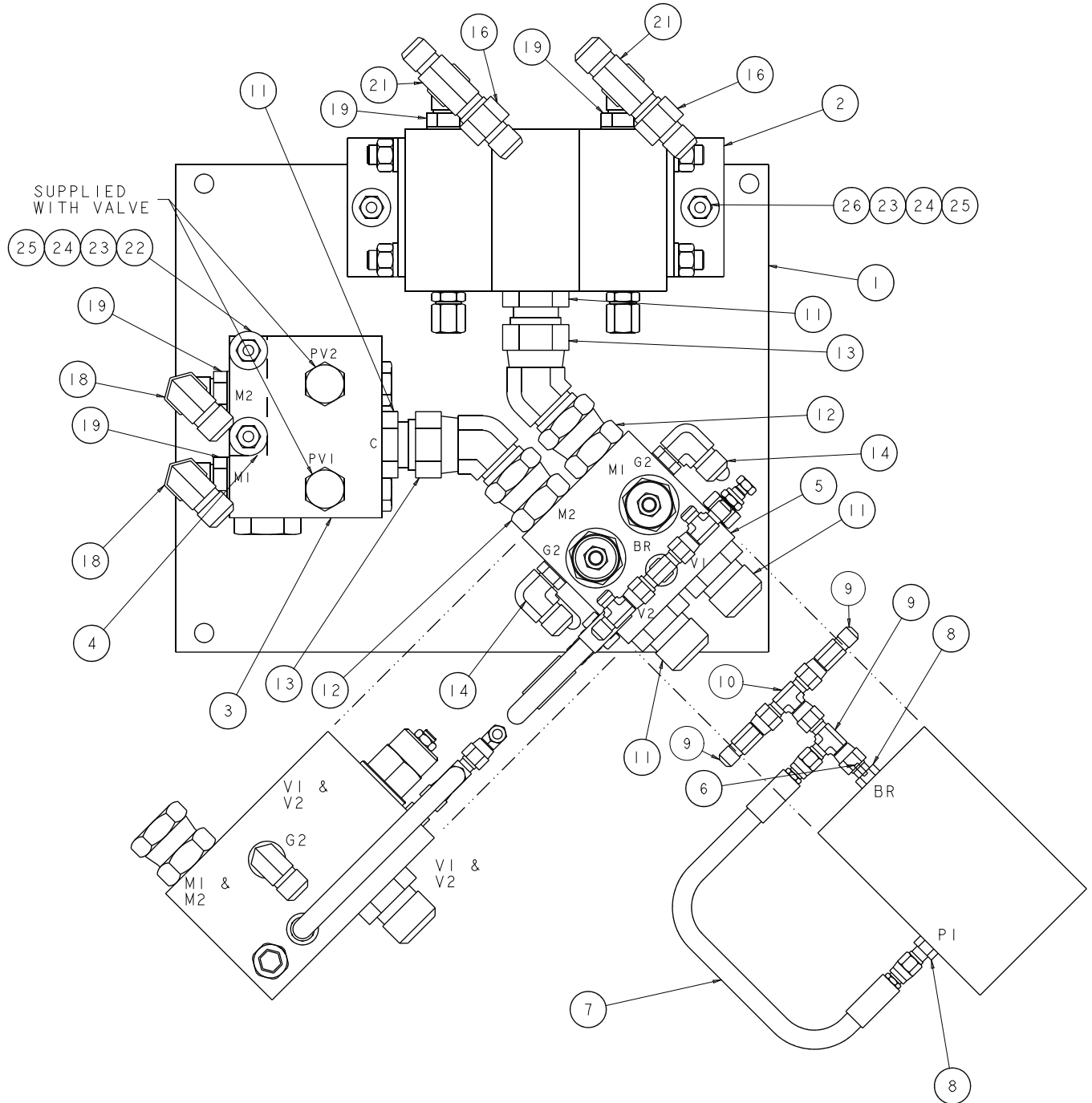

0112807

# Motion Control Valve, Drive

## Motion Control Valve, Drive

Item	Part No.	Qty.	Description
1	0151728	1	PLATE
2	6030036	1	FLOW DIVIDER
3	6010570	1	VALVE PACKAGE
4	0180809	1	BAR
5	6019052	1	PACKAGE VALVE
6	0181077	1	ORIFICE
7	0181161	1	HOSE-4-4S-4S 15.25 R100R2
8	5065703	2	FTG ADPTR STRTHD-4B-4S STL
9	5036703	3	FTG TEE SWVL RUN-4S-4S STL
10	5036803	1	FTG TEE SWVL BR-4S-4S STL
11	5065718	4	FTG ADPTR STRTHD-16B-16S STL
12	5025002	2	FTG ADPTR SWVL-16B-16S STL
13	5036910	2	FTG ELB45SWVL-16S-16S STL
14	5035315	2	FTG ELB90STRTHD-6B-8S STL
16	5064005	2	FTG RDCR TUBE END-10S-8S STL
17	0181092	1	SPACER
18	5037007	2	FTG ELB90SWVL-10S-10S STL
19	5035307	4	FTG ELB90STRTHD-10S-10S STL
21	5036807	2	FTG TEE SWVL BR-10S-10S STL
22		2	BLT CARR .375-16 4.5 RDSQNK
23	987119	4	WASHER LOCK .375 MDM
24	986299	4	WASHER FLAT .375
25	984109	4	NUT HEXHD .375-16
26		2	BLT CARR .375-16 1.25 RDSQNK

## Motion Control Valve, Drive



## Motion Control Valve, Turntable Rotation

Item	Part No.	Qty.	Description
1	6010216	1	Motion control valve, turntable rotation - (valve includes items 2, 3 and 4)
	0110682	1	Seal repair kit
2	6010255	2	Sequence valve cartridge - (factory preset, do not reset)
3	6010256	2	Counterbalance cartridge - (factory preset, do not reset)
4	6010531	1	Shuttle valve
	0150562	1	Seal repair kit

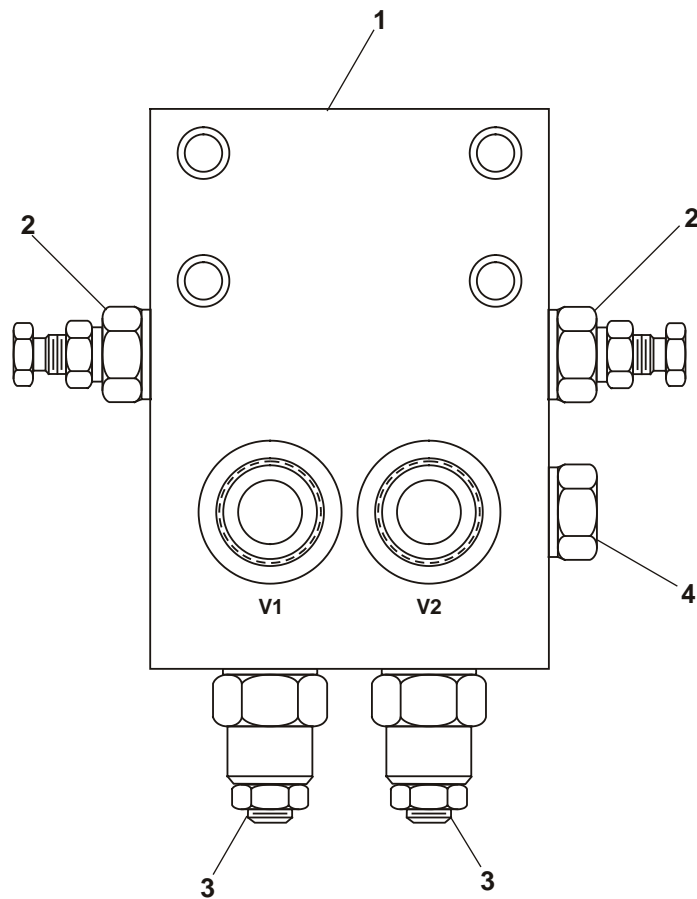

AW6010216

## Motion Control Valve, Turntable Rotation



## Pressure Manifold

Item	Part No.	Qty.	Description
	0111879	1	PRESSURE MANIFOLD
1	6010579	1	VALVE, PRESSURE MANIFOLD - (INCLUDES CHECK VALVE CARTRIDGE)
2	6010565	1	CHECK VALVE CARTRIDGE - (FACTORY PRESET, DO NOT RESET)
	6010605	1	SEAL REPAIR KIT
3	5035710	1	STRAIGHT THREAD 45° ELBOW
4	5035305	1	STRAIGHT THREAD 90° ELBOW
5	5037005	1	SWIVEL NUT 90° ELBOW
6	5035303	1	STRAIGHT THREAD 90° ELBOW
7	5065708	1	STRAIGHT THREAD ADAPTER
8	5036905	1	SWIVEL NUT 45° ELBOW
9	5036703	1	SWIVEL NUT RUN TEE
10	5036505	1	STRAIGHT THREAD BRANCH TEE
11	5063703	1	CAP
12	5064001	1	TUBE END REDUCER
13	5063905	1	FITTING NUT
14	5035310	1	STRAIGHT THREAD 90° ELBOW

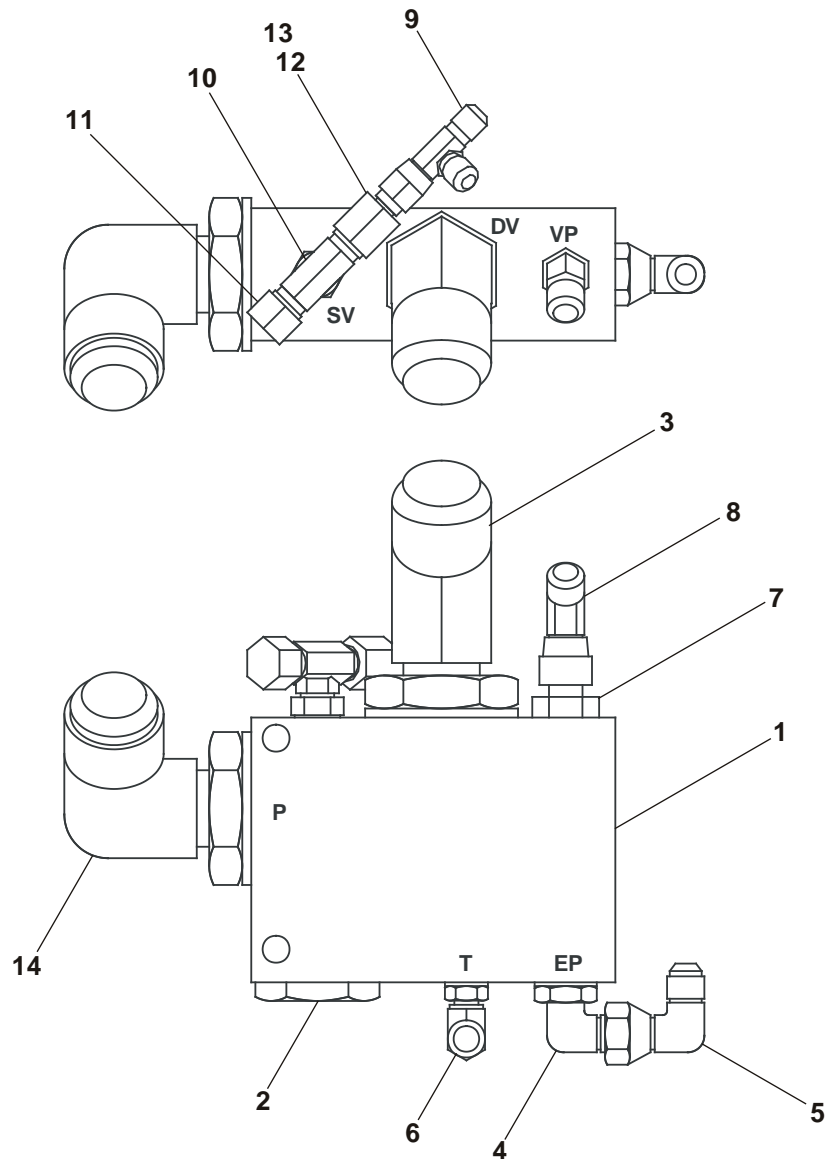

## Pressure Manifold

AW0111879



## Four Wheel Steer Valve

Item	Part No.	Qty.	Description
1	0112821	1	VALVE, 4 WHEEL STEER
	6091144	1	SEAL KIT
	6091558	1	COIL
2	5065707	3	FTG ADPTR STRTHD-6B-6S STL
3	5065805	1	FTG ADPTR STRTHD-LG -6B-6S STL

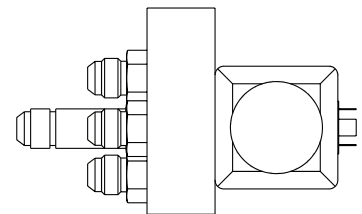
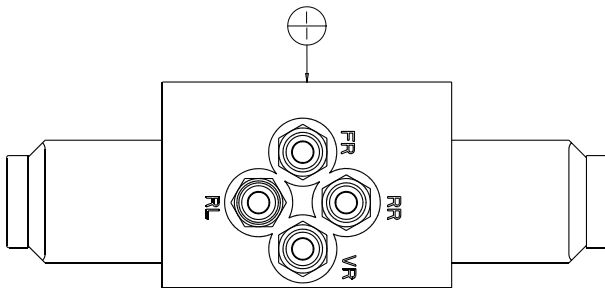
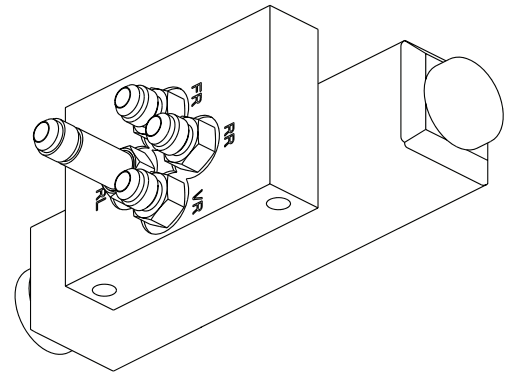
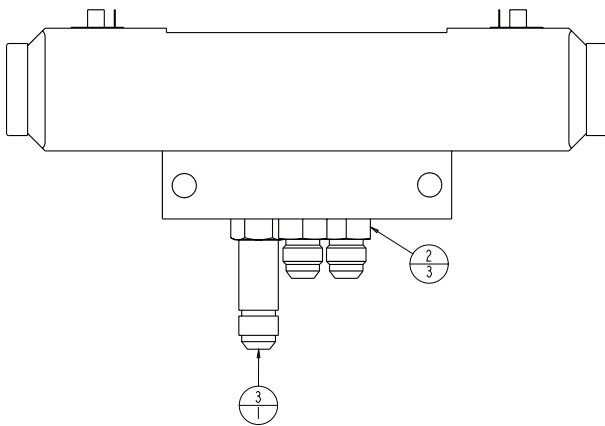

0112826

## Four Wheel Steer Valve



## Speed Shift Valve

Item	Part No.	Qty.	Description
1	5035305	1	FTG ELB90STRTHD-6B-6S STL
2	5035318	2	FTG ELB90STRTHD-6B-4S
3	5066705	1	FTG TEE SWVL RUN-6S-6S STL
4	5065705	1	FTG ADPTR STRTHD-6B-4S STL
5	6010610	1	VALVE
	6019113	1	CARTRIDGE WITH COIL

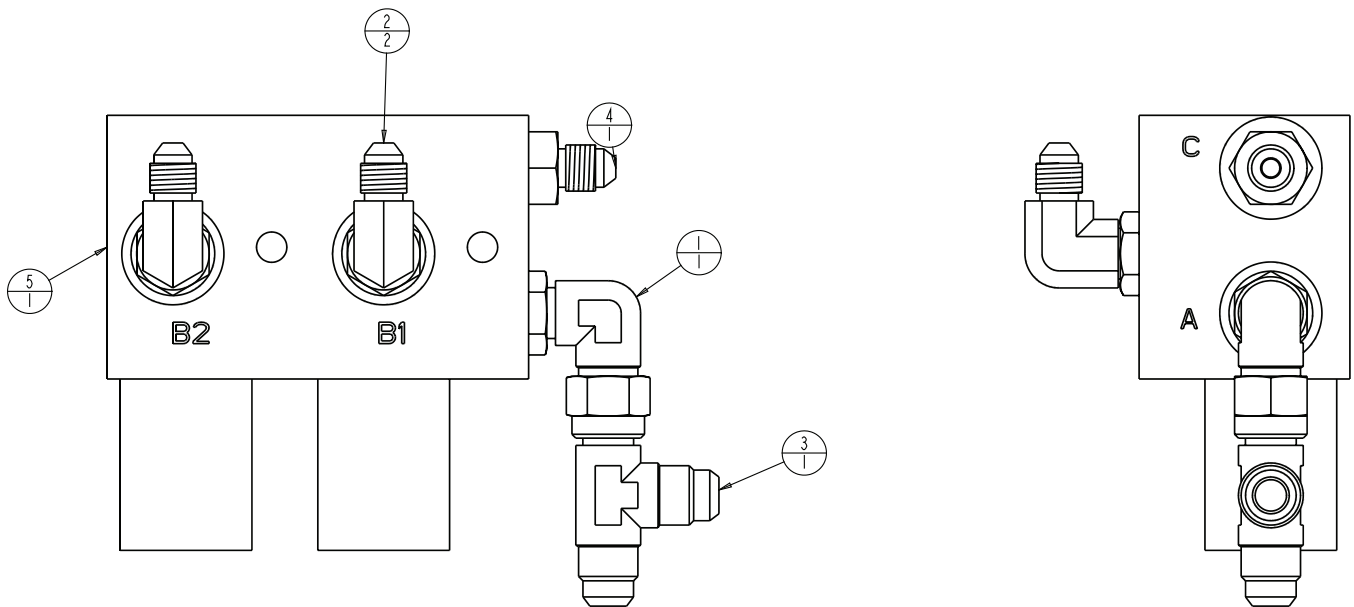

0112829

## Speed Shift Valve





## Oil Return Filter

Item	Part No.	Qty.	Description
1	0112029	1	HYDRAULIC OIL RETURN FILTER
	5080044	1	FILTER – INCLUDES ELEMENT AND MANIFOLD
	5080017	1	FILTER ELEMENT
2	5080011	1	FILTER GAUGE
3	5037011	1	SWIVEL NUT 90 DEGREE ELBOW
4	5065721	1	STRAIGHT THREAD ADAPTER

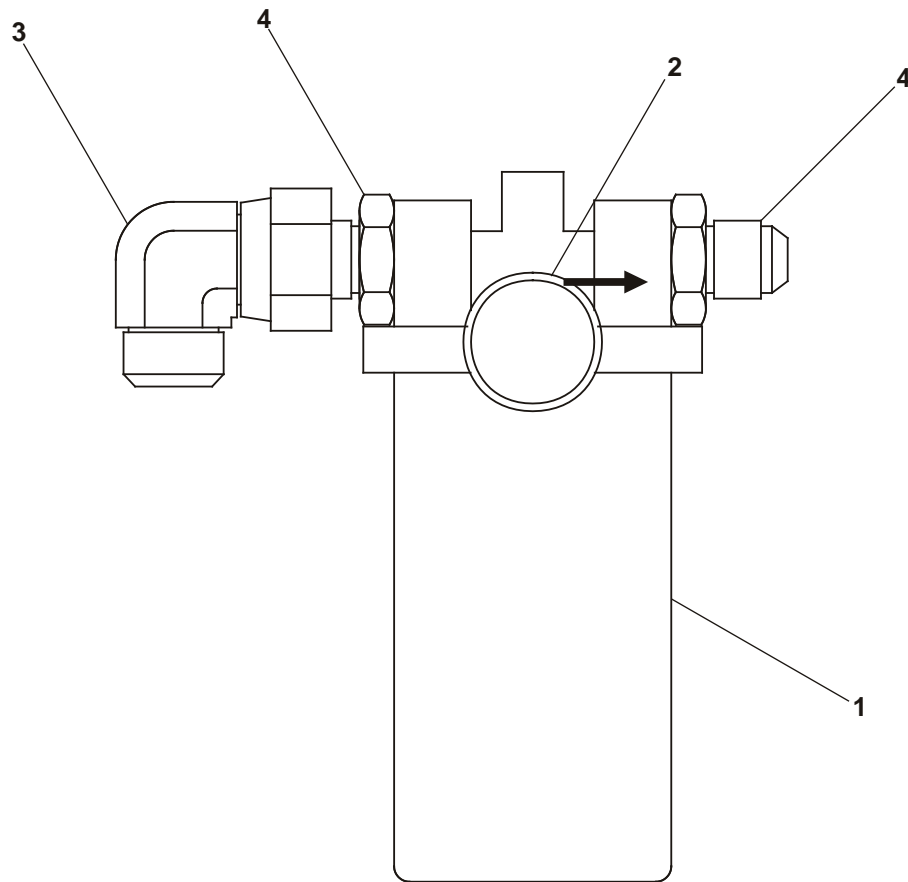

AW0112029

## Oil Return Filter



## Front Transmission Valve

Item	Part No.	Qty.	Description
1	5035307	1	FTG ELB90STRTHD-10B-10S STL
2	5035316	3	FTG ELB90STRTHD-10B-8S STL
3	5036705	1	FTG TEE SWVL RUN-6S-6S STL
4	5037005	1	FTG ELB90SWVL-6S-6S STL
5	5037007	1	FTG ELB90SWVL-10S-10S STL
6	5065734	1	FTG ADPTR STRTHD-4B-6S STL
7	5065807	1	FTG ADPRT STRTHD LG-10B-10S STL
8	6010569	1	TRANSMISSION VALVE PACKAGE

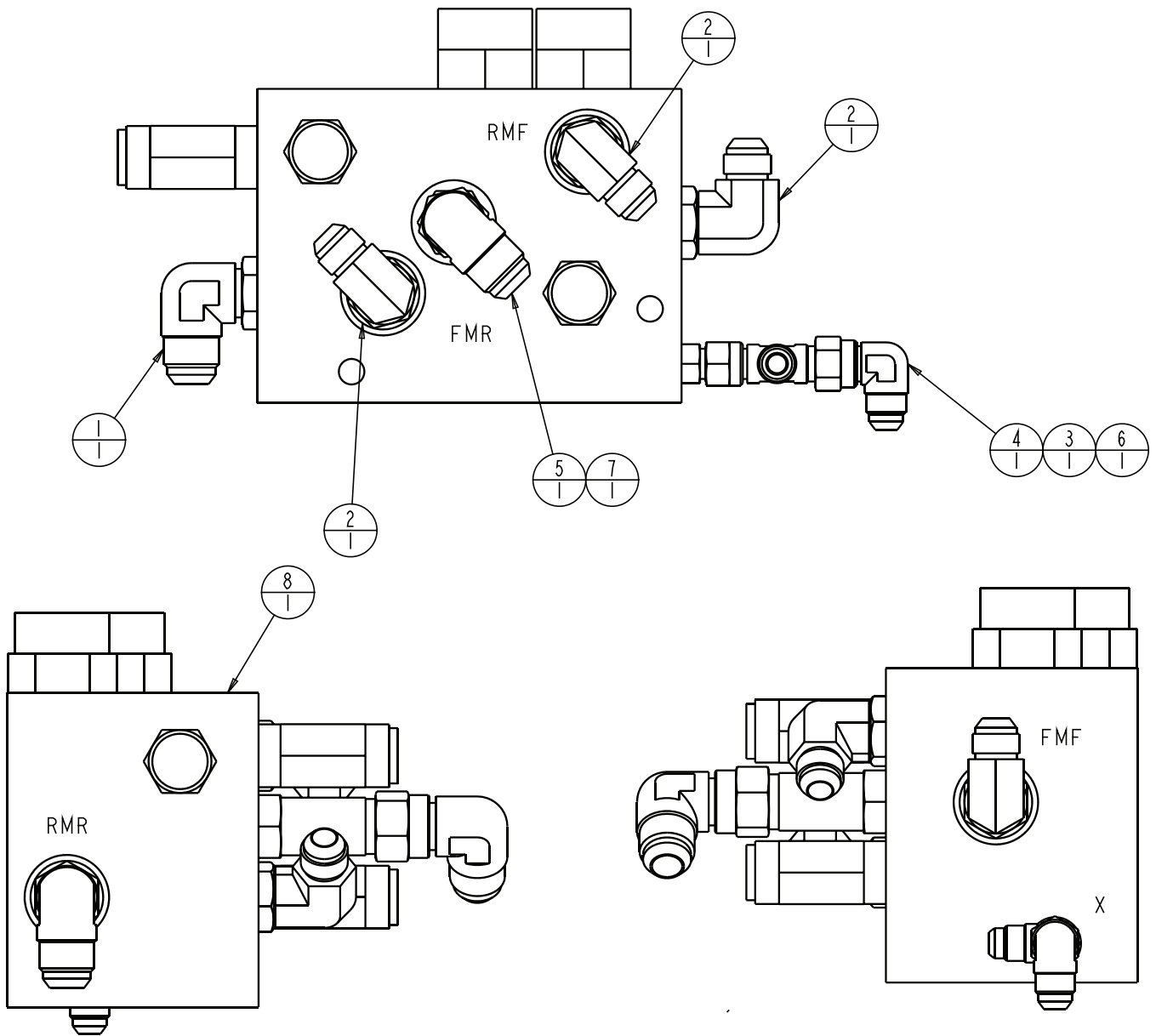

0112805

## Front Transmission Valve



## Rear Transmission Valve

Item	Part No.	Qty.	Description
1	5035316	2	FTG ELB90STRTHD-10B-8S STL
2	5035707	1	FTG ELB45STRTHD-10B-10S STL
3	5037005	1	FTG ELB90SWVL-6S-6S STL
4	5037007	1	FTG ELB90SWVL-10S-10S STL
5	5065710	1	FTG ADPTR STRTHD-10B-8S STL
6	5065734	1	FTG ADPTR STRTHD-4B-6S STL
7	5065807	1	FTG ADPTR STRTHD LG-10B-10S STL
8	6010569	1	TRANSMISSION VALVE PACKAGE

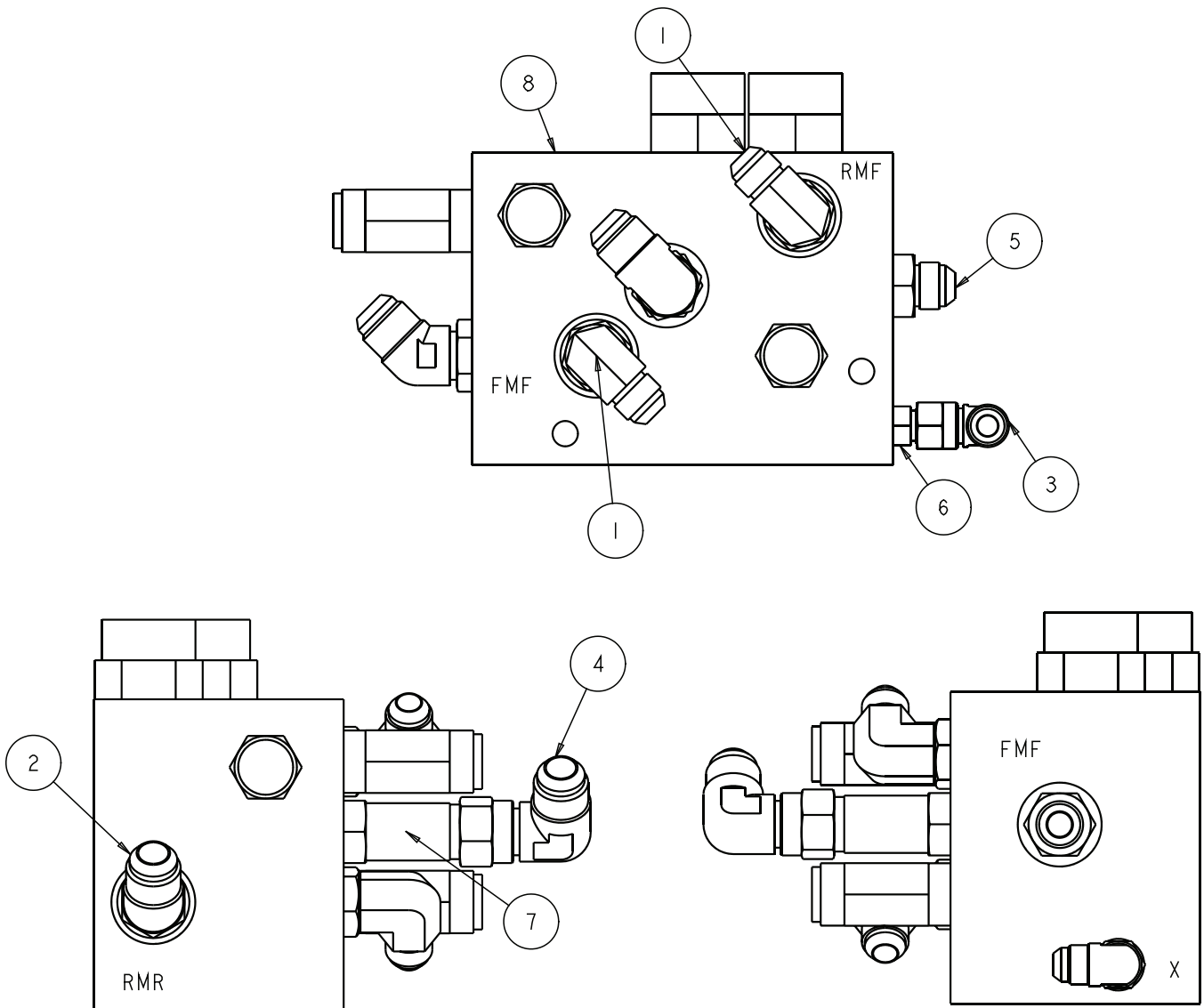

0112806

## Rear Transmission Valve



## Chassis Accumulator

Item	Part No.	Qty.	Description
1	018108328	1	ACCUMULATOR, SHIPPED CHARGED
2	6070005	1	ACCUMULATOR, SHIPPED UNCHARGED – CHARGE TO 300 PSI WITH DRY NITROGEN BEFORE USE
3	5076003	1	ADAPTER STRAIGHT -12SAE TO -8SAE FEMALE
4	6010635	1	CHECK VALVE, WITH ORIFICE
5	5065709	1	ADAPTER STRAIGHT -8SAE TO -8JIC

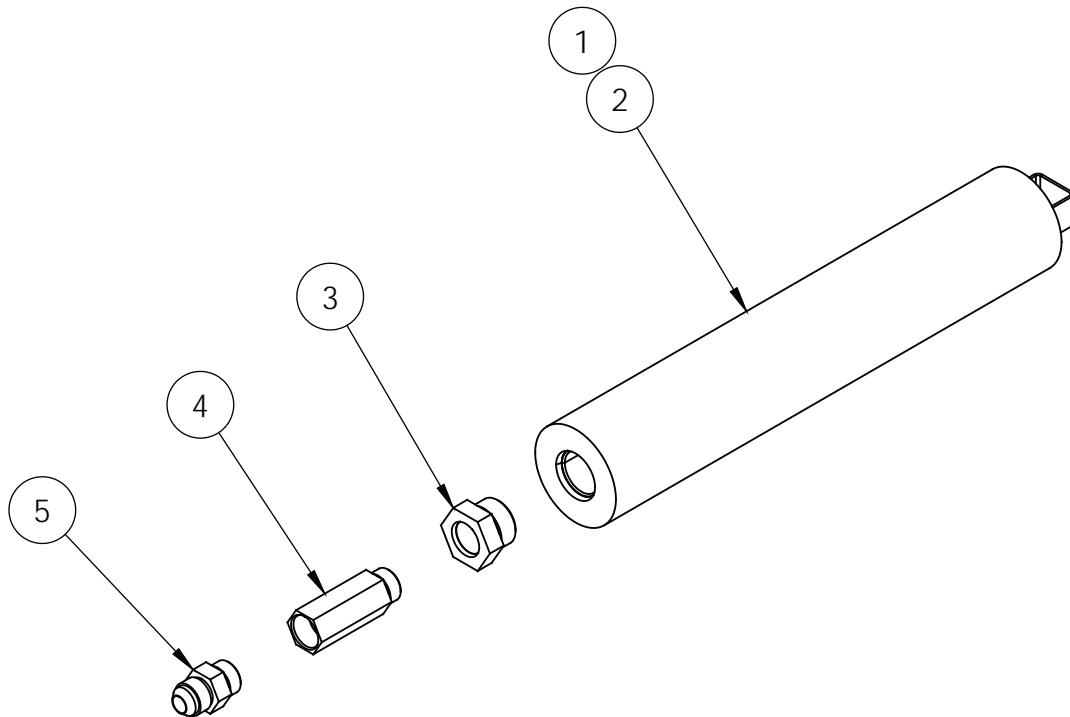

0181083

## Chassis Accumulator





# *Electrical*

TB80

TB85J



 **snorkel**



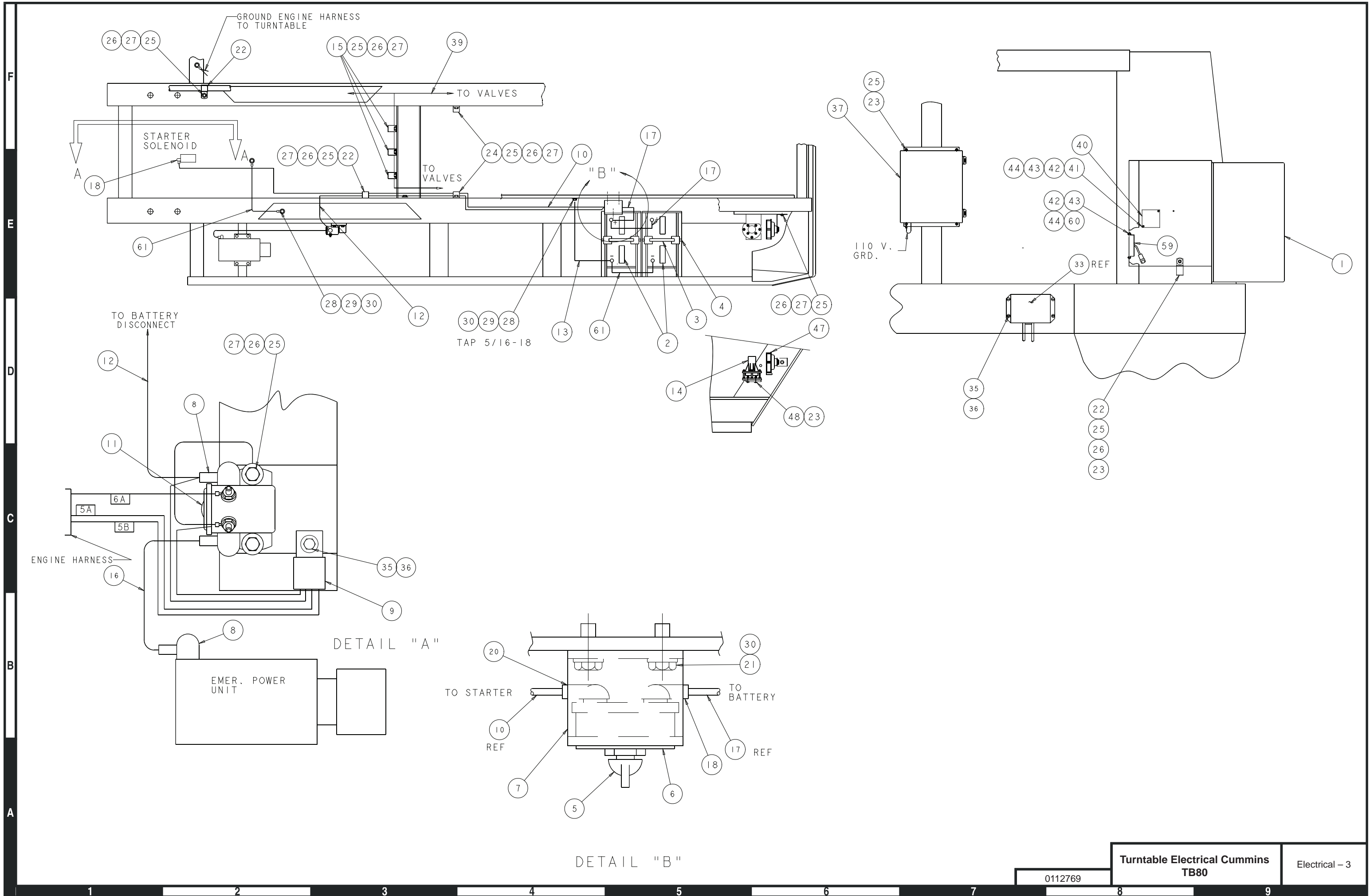

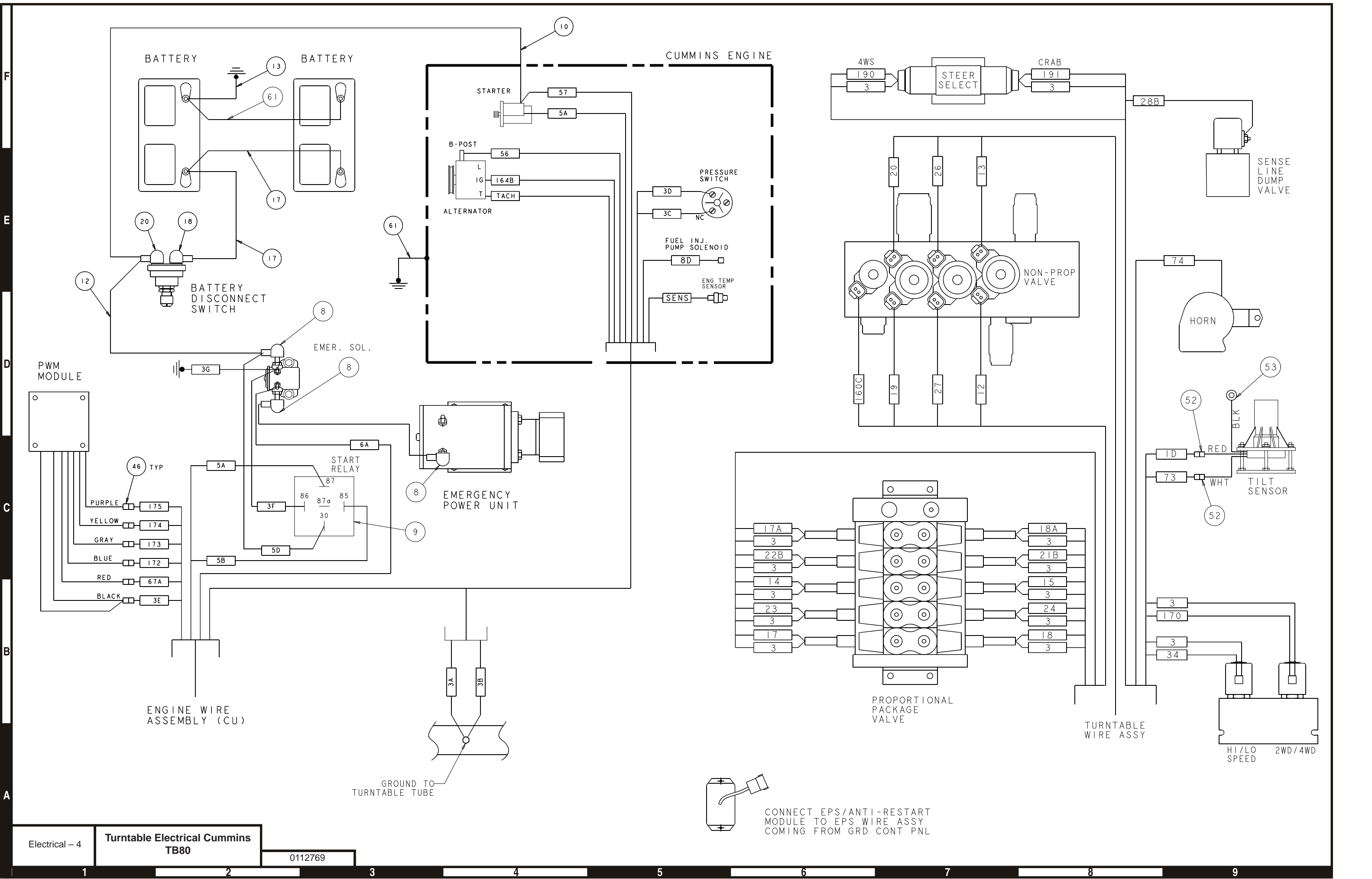

CONNECT EPS/ANTI-RESTART  
MODULE TO EPS WIRE ASSY  
COMING FROM GRD CONT PNL

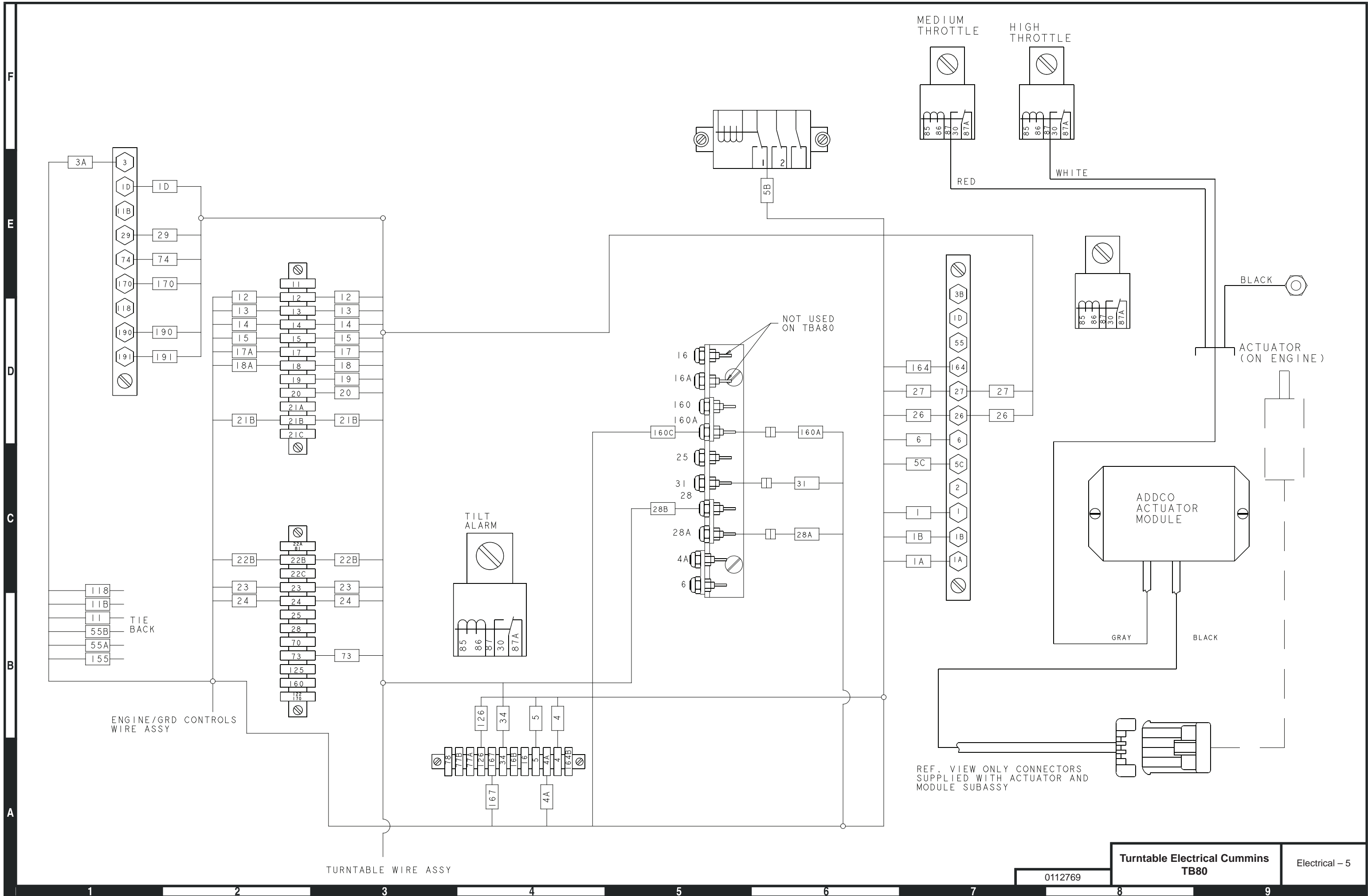

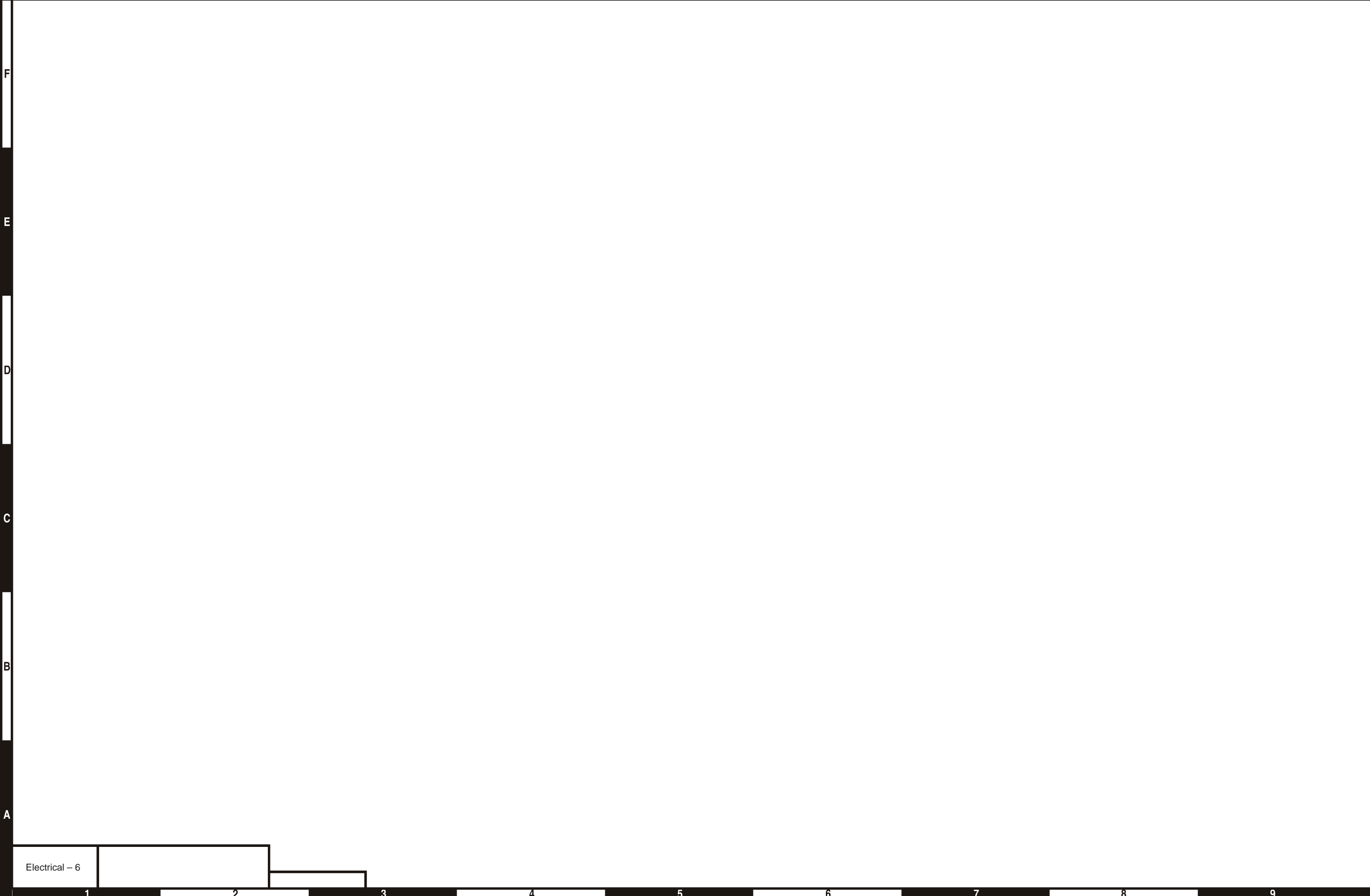

F

E

D

C

B

A



Electrical - 6

1

2

3

4

5

6

7

8

9

## Turntable Electrical, Cummins – TB80

Item	Part No.	Qty.	Description
1	0112856	1	GROUND CONTROL PANEL ASSEMBLY
2	3050002	2	BATTERY
3	3050008	2	BATTERY HOLDDOWN
4	3050004	4	BATTERY HOLDDOWN BOLT
5	3040049	1	SWITCH, BATTERY DISCONNECT
6	0073089	1	PLACARD
7	0073051	1	BRACKET, BATTERY DISCONNECT
8	3040268	3	BOOT
9	3040469	1	RELAY SPDT 12V 30AMP
10	0110529	1	BATTERY WIRE
11	3040506	1	SOLENOID
12	0070705	1	BATTERY WIRE
13	0080483	1	BATTERY WIRE
14	3020040	1	TILT ALARM SENSOR
15	5093002	3	CLAMP
16	0072323	1	BATTERY WIRE
17	0080484	2	WIRE 2/0 R375 R375 13 RED
18	3040286	2	BOOT
19	5093027	1	CLAMP
20	3040270	1	BOOT BATTERY CABLE END Y-TYPE
21	970249	2	BOLT HEXHD .313-18 X .88 GR5
22	5093008	3	CLAMP
23	5560004	9	NUT LKG .25-20 ESNA
24	5093006	4	CLAMP
25	970029	17	BOLT HEXHD .25-20 X .75 GR5
26	986019	12	WASHER FLAT .25
27	987099	14	WASHER LOCK .25 MDM
28	970239	2	BOLT HEXHD .313-18 X .75 GR5
29	986269	2	WASHER FLAT .313
30	987109	4	WASHER LOCK .313 MDM
33	0082046	1	ACTUATOR MODULE (WITH ENGINE)
35	974679	2	SCREW RHD #10-24 X .50 PLATED
36	5560365	5	WASHER LOCK #10
37	0112744	1	WIRING BOX SUB ASSEMBLY
39	0112788	1	TURNTABLE WIRE ASSEMBLY
40	3040534	1	PDM MODULE
41		2	M. SCREW #6-32 X 1 LG TRUSS HD
42	987349	4	WASHER #6 MEDIUM LOCK
43	986159	4	WASHER #6 FLAT
44	984009	4	NUT #6-32 HEX
45	3044146	2	TERM, #10 STUD INS 22/18 WIRE
46	3040046	6	TERM, .250 MALE SLIP-ON F.I. 22/18 WIRE
47	3040127	1	HORN
48		4	CAPSCREW 1/4-20 X 1 LG HH
51	0071545	1	JUMPER WIRE
52	3040082	2	TERM, .250 MALE SLIP ON F.I. 16/14 WIRE
53	3044162	1	TERM, 1/4 STUD INS. 16/14 WIRE
59	3040122	1	EPS/ANTI-RESTART MODULE
60	974239	2	SCREW RHD #6-32 .50
61	0075268	2	WIRE 2/0 R375 R375 13 BLK

## Turntable Electrical, Cummins – TB80





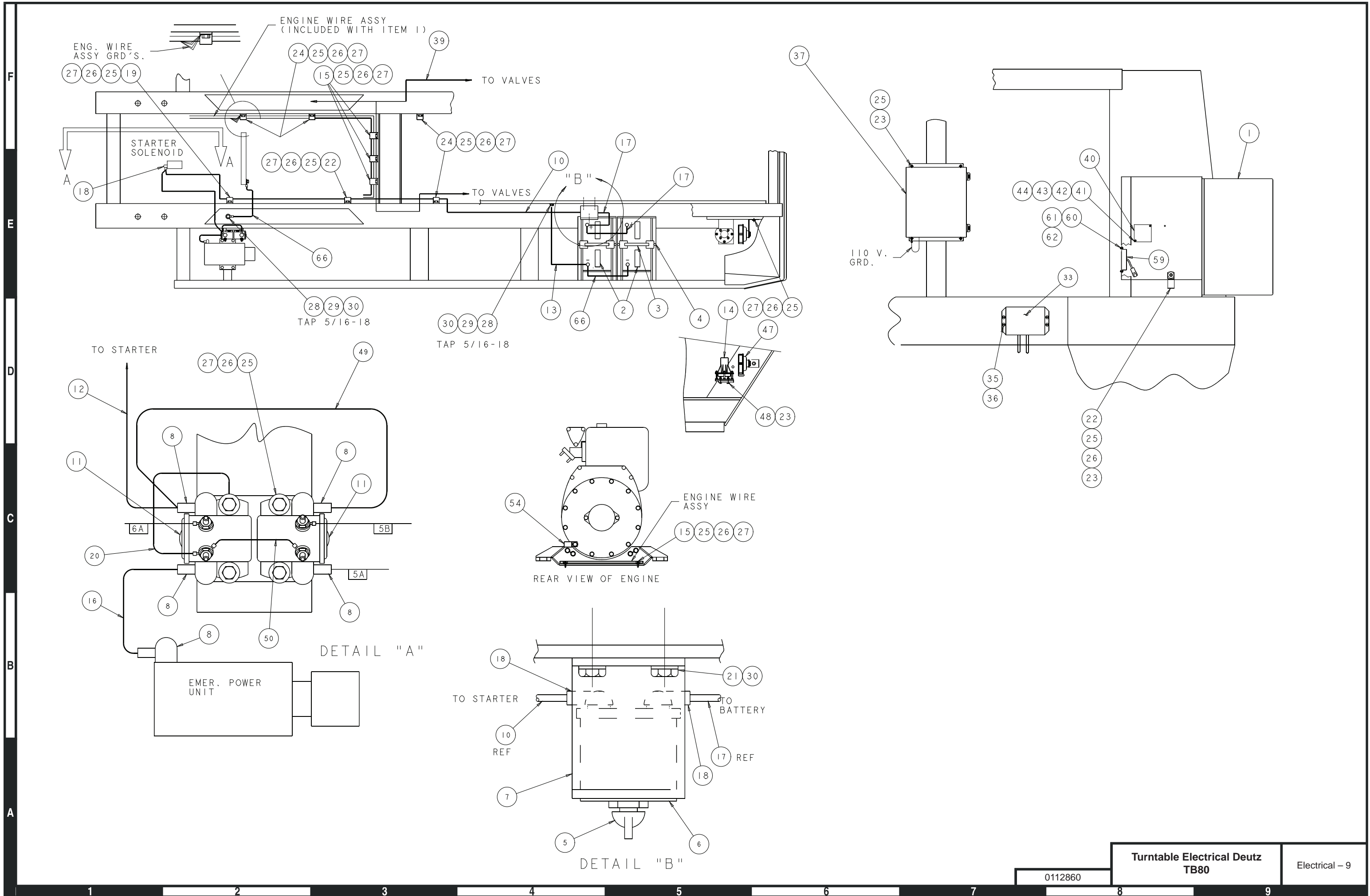

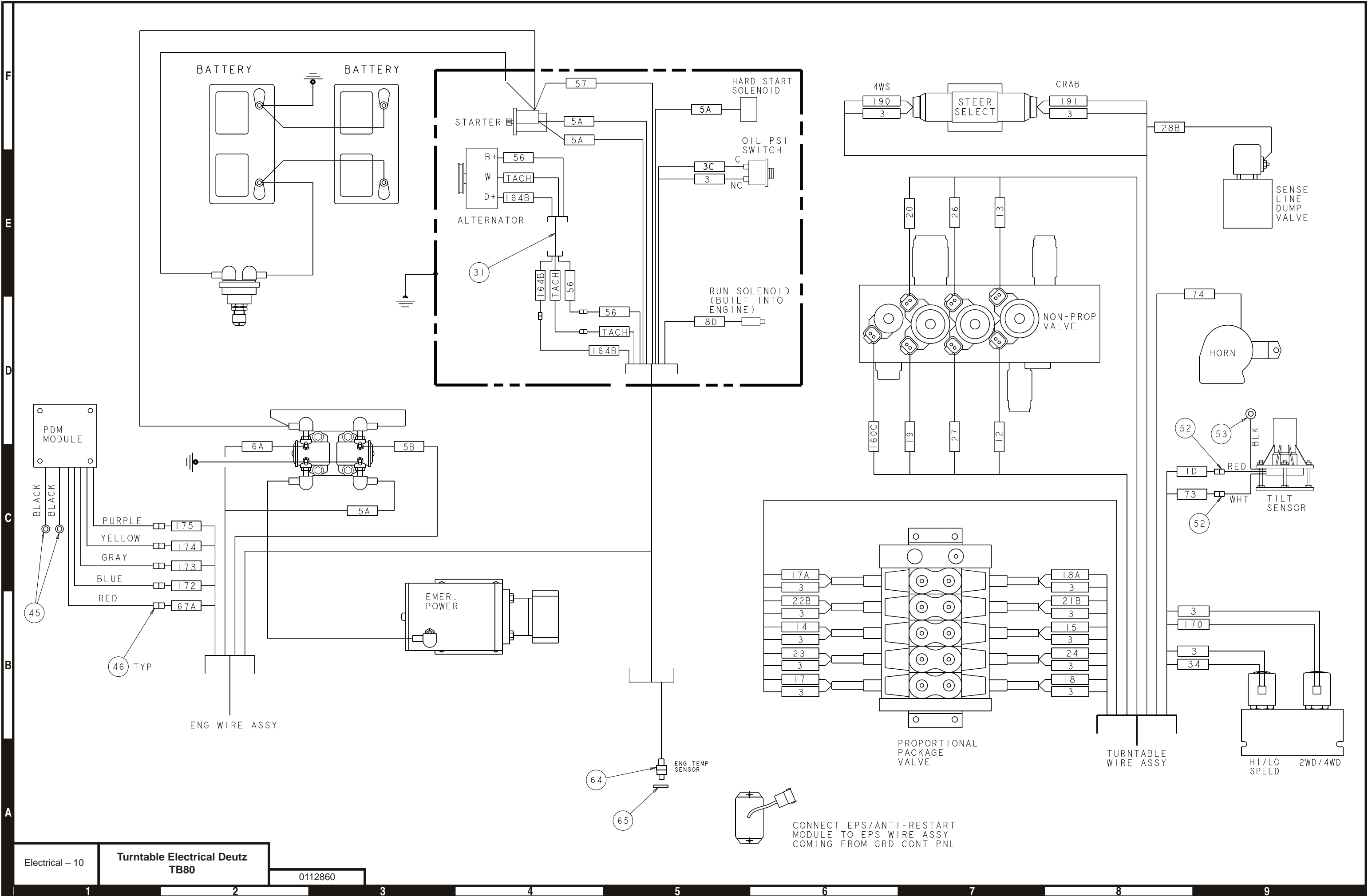

CONNECT EPS/ANTI-RESTART  
MODULE TO EPS WIRE ASSY  
COMING FROM GRD CONT PNL

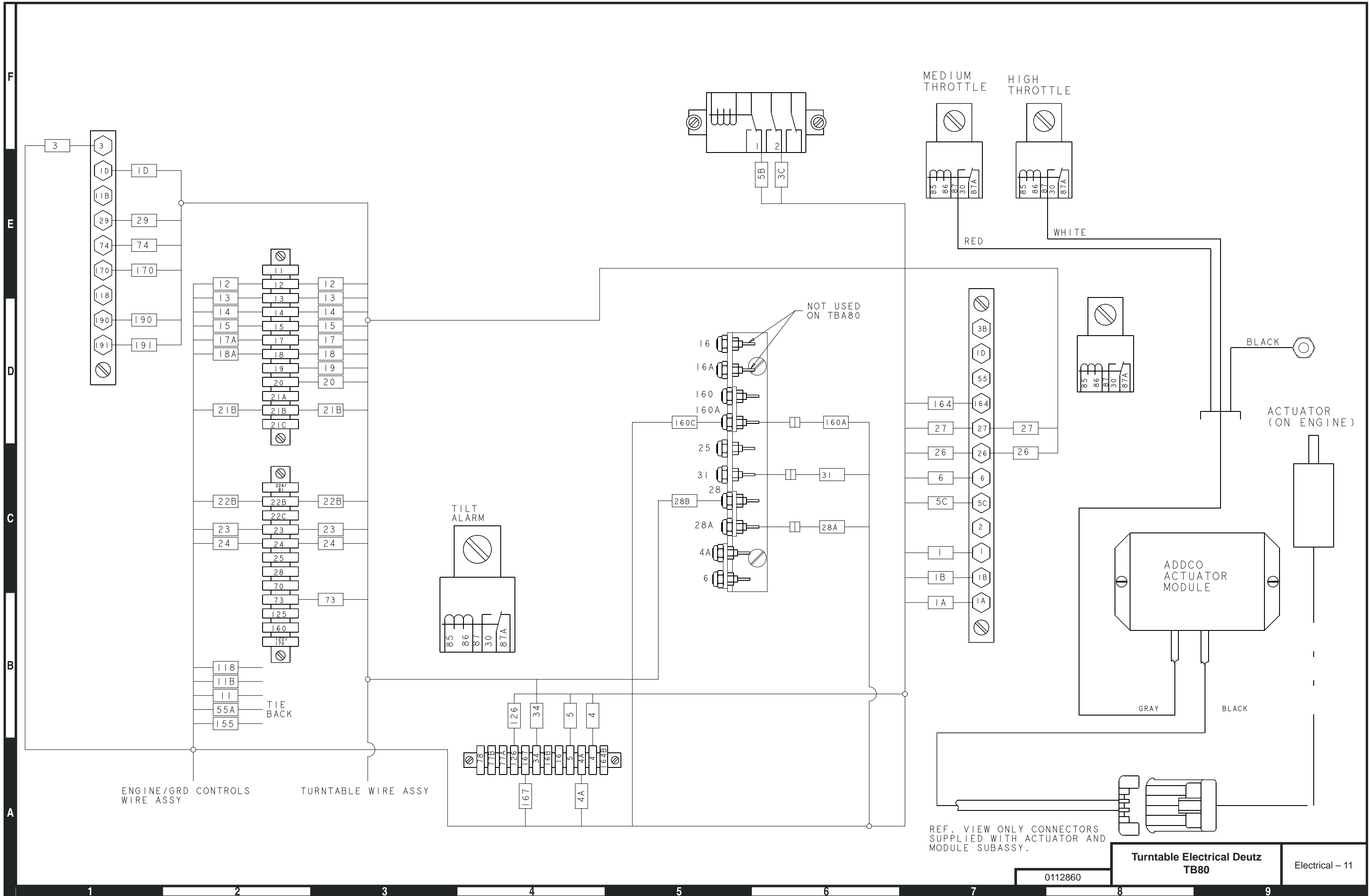

REF. VIEW ONLY CONNECTORS SUPPLIED WITH ACTUATOR AND MODULE SUBASSY.

Turntable Electrical Deutz TB80

Electrical - 11

0112860

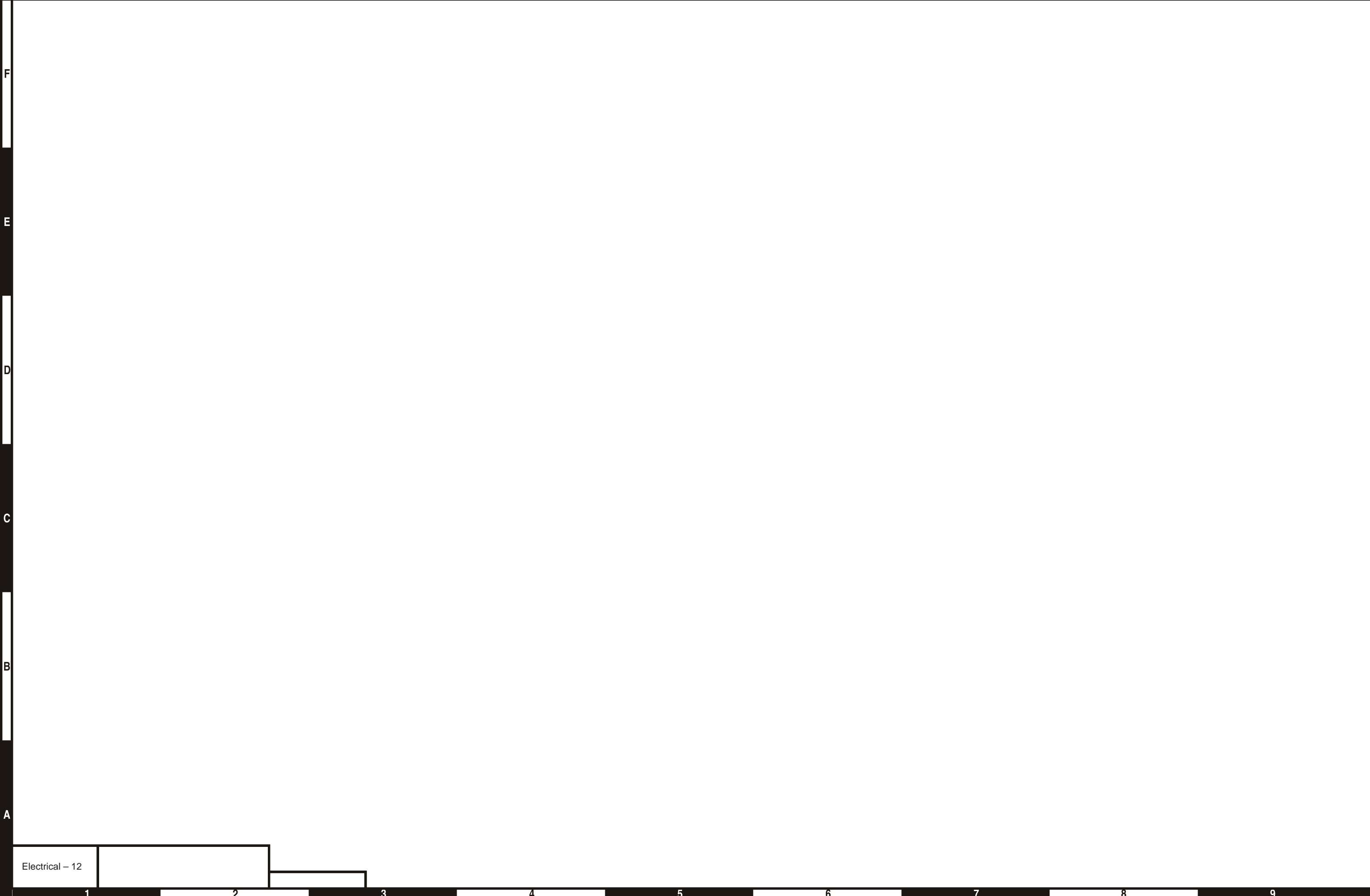

F

E

D

C

B

A

Electrical - 12

1

2

3

4

5

6

7

8

9

## Turntable Electrical, Deutz – TB80

Item	Part No.	Qty.	Description
1	0112757	1	GROUND CONTROL PANEL ASSEMBLY
2	3050002	2	BATTERY
3	3050008	2	BATTERY HOLDDOWN
4	3050004	4	BATTERY HOLDDOWN BOLT
5	3020049	1	SWITCH, BATTERY DISCONNECT
6	0073089	1	PLACARD
7	0073051	1	BRACKET, BATTERY DISCONNECT
8	3040268	5	BOOT
10	0110529	1	BATTERY WIRE
11	6040506	2	SOLENOID
12	0151160	1	BATTERY WIRE
13	0080483	1	BATTERY WIRE
14	3020040	1	TILT ALARM SENSOR
15	5093000	5	CLAMP
16	0072323	1	BATTERY WIRE
17	0080484	2	WIRE 2/0 R375 R375 13 RED
18	3040269	3	BOOT
19	5093027	1	CLAMP
20	0071568	1	JUMPER WIRE
21	970249	2	BOLT HEXHD .313-18 .875 GR5
22	5093008	2	CLAMP
23	5560004	7	NUT LKG .250-20
24	5093006	4	CLAMP
25	970029	20	BOLT HEXHD .250-20 .75 GR5
26	986019	17	WASHER FLAT .250
27	987099	16	WASHER LOCK .250 MDM
28	970239	2	BOLT HEXHD .313-18 .75 GR5
29	986269	2	WASHER FLAT .313
30	987109	4	WASHER LOCK .313 MDM
31	0074579	1	ALTERNATOR HARNESS
33	0082046	1	ACTUATOR MODULE (WITH ENGINE)
35	974689	4	SCREW RHD #10-24 .75 PLATED
36	5560654	4	WASHER LOCK #10 PLATED
37	0112744	1	WIRING BOX SUB ASSEMBLY
39	0112788	1	TURNTABLE WIRE ASSEMBLY
40	3040534	1	PDM MODULE
41		2	SCREW TRUSS HD #6-32 1.00 PLATED
42	5560664	4	WASHER LOCK #6 MDM
43	986159	4	WASHER FLAT #6
44	984009	4	NUT HEX #6-32
45	3044146	2	TERM, #10 STUD, INS 22/18 WIRE
46	3040046	5	TERM, .250 MALE SLIP-ON F.I. 22/18 WIRE
47	3040127	1	HORN
48	970049	4	BOLT HEXHD .250-20 1.00 GR5
49	0151919	1	JUMPER WIRE
50	0151371	1	JUMPER WIRE
51	0071545	1	JUMPER WIRE
52	3040082	2	TERM, .250 MALE SLIP-ON F.I. 16/14
53	3044162	1	TERM, 1/4 STUD INS. 16/14 WIRE
54	5093010	1	CLAMP
59	3030122	1	ENGINE PROTECTION MODULE HIGH
60	974239	2	SCREW RHD #6-32 .50
61	984009	2	NUT HEX 6-32 PLATED
62	986159	2	WASHER FLAT #6
64	3070039	1	TEMP SENSOR M18 X 1.5 HIGH
65	5569837	1	WASHER FLAT M18 COPPER
66	0075268	2	WIRE 2/0 R375 R375 13 BLACK

## Turntable Electrical, Deutz – TB80



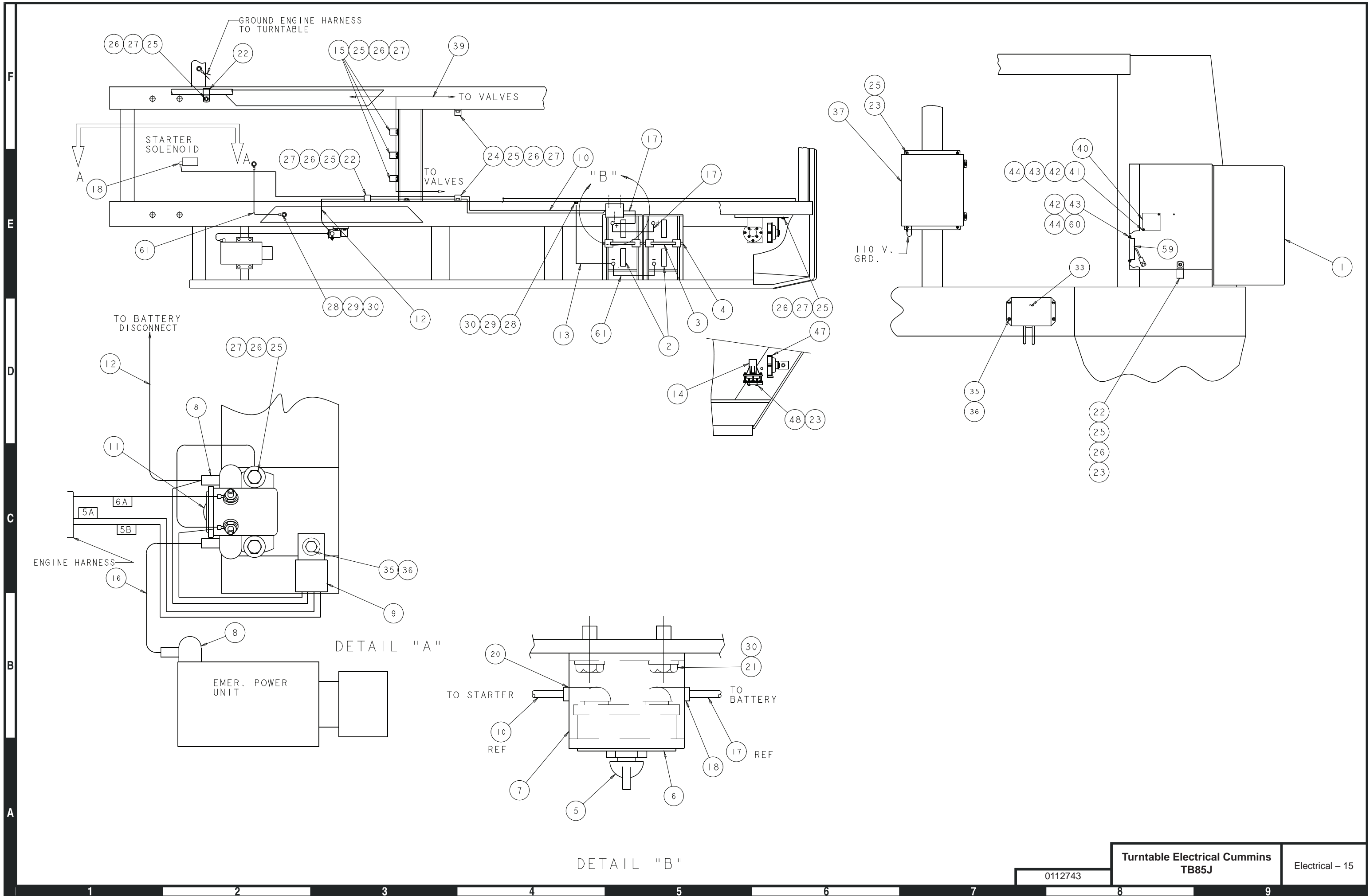

F  
E  
D  
C  
B  
A

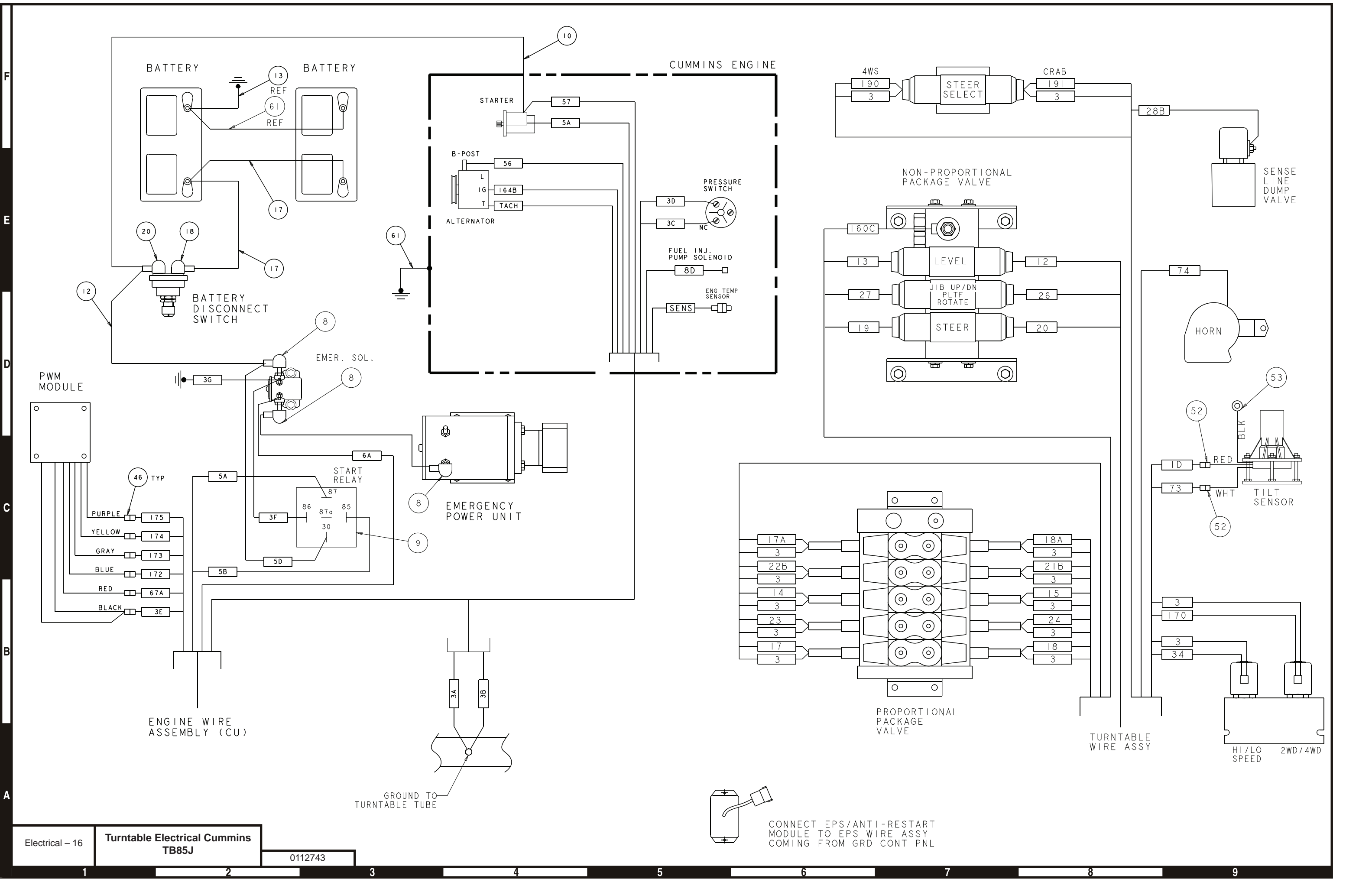

CONNECT EPS/ANTI-RESTART MODULE TO EPS WIRE ASSY COMING FROM GRD CONT PNL

F  
E  
D  
C  
B  
A

1      2      3      4      5      6      7      8      9



F

E

D

C

B

A

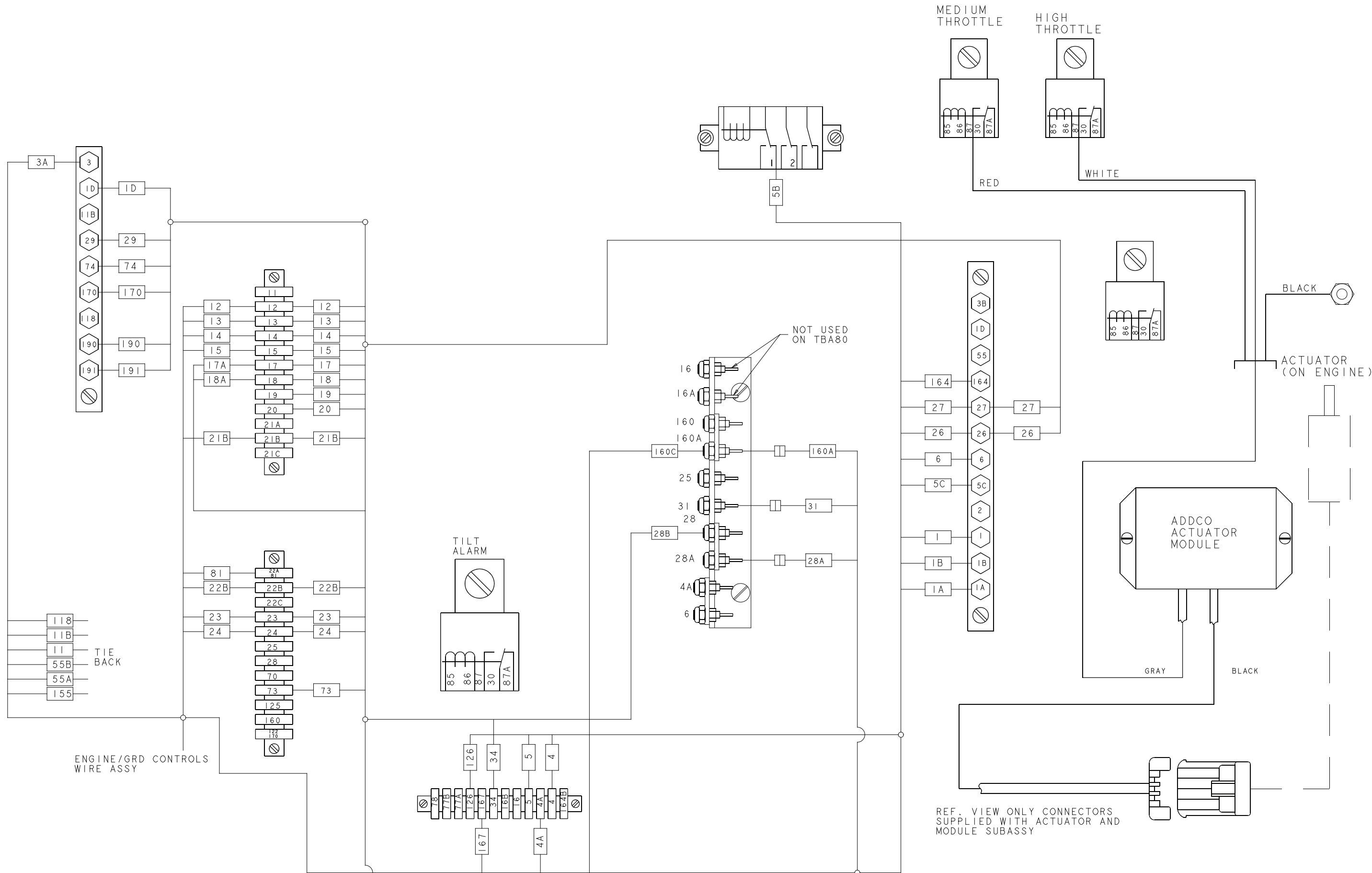

ENGINE/GRD CONTROLS WIRE ASSY

TURNTABLE WIRE ASSY

TILT ALARM

NOT USED ON TBA80

REF. VIEW ONLY CONNECTORS SUPPLIED WITH ACTUATOR AND MODULE SUBASSY

Turntable Electrical Cummins TB85J

Electrical - 17

0112743

1 2 3 4 5 6 7 8 9

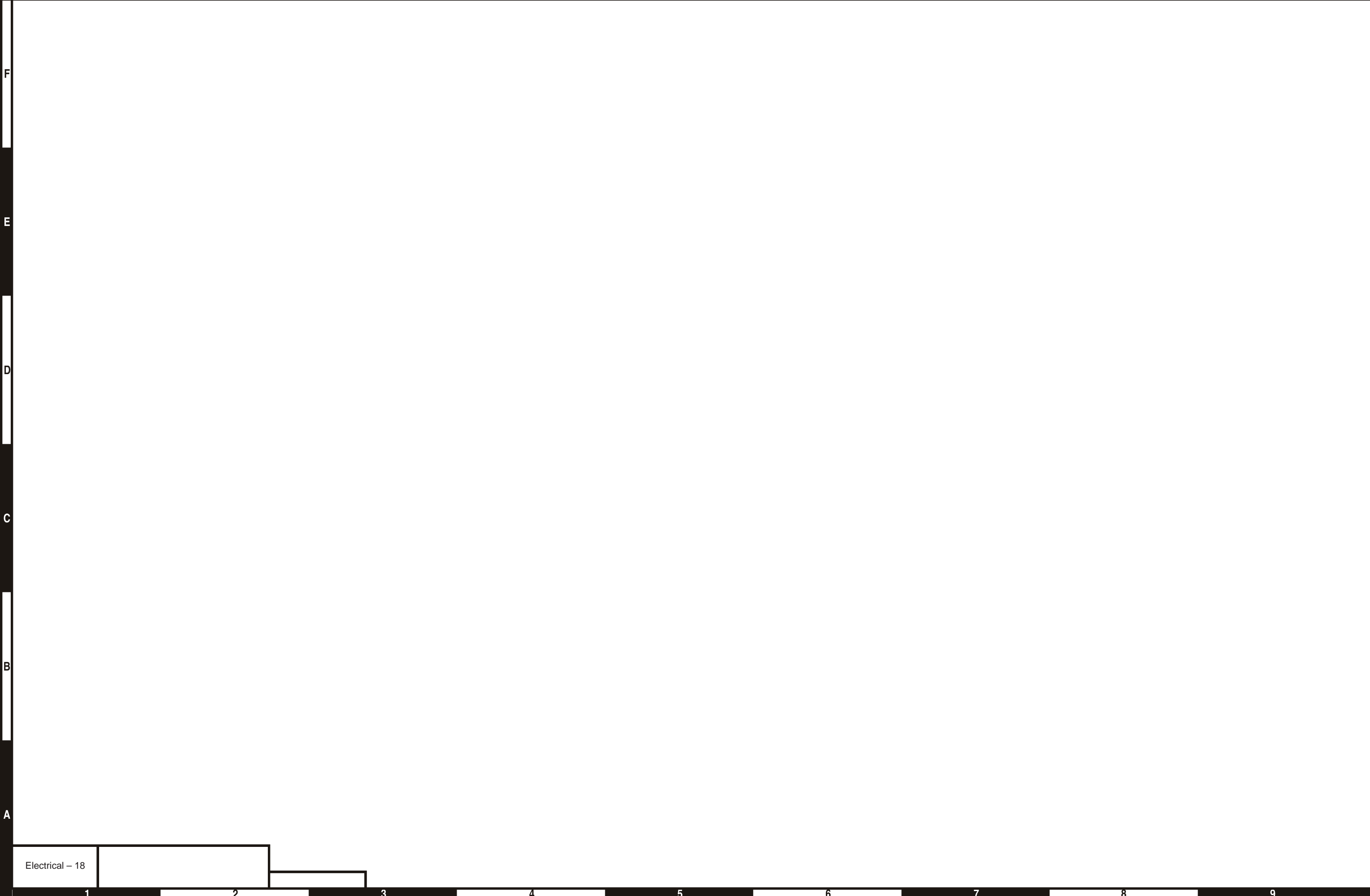

F

E

D

C

B

A

Electrical - 18

1

2

3

4

5

6

7

8

9

## Turntable Electrical, Cummins – TB85J

Item	Part No.	Qty.	Description
1	0112745	1	GROUND CONTROL PANEL ASSEMBLY
2	3050002	2	BATTERY
3	3050008	2	BATTERY HOLDDOWN
4	3050004	4	BATTERY HOLDDOWN BOLT
5	3040049	1	SWITCH, BATTERY DISCONNECT
6	0073089	1	PLACARD
7	0073051	1	BRACKET, BATTERY DISCONNECT
8	3040268	3	BOOT
9	3040469	1	RELAY SPDT 12V 30AMP
10	0110529	1	BATTERY WIRE
11	3040506	1	SOLENOID
12	0070705	1	BATTERY WIRE
13	0080483	1	BATTERY WIRE
14	3020040	1	TILT ALARM SENSOR
15	5093002	3	CLAMP
16	0072323	1	BATTERY WIRE
17	0080484	2	WIRE 2/0 R375 R375 13 RED
18	3040286	2	BOOT
19	5093027	1	CLAMP
20	3040270	1	BOOT BATTERY CABLE END Y-TYPE
21	970249	2	BOLT HEXHD .313-18 X .88 GR5
22	5093008	3	CLAMP
23	5560004	9	NUT LKG .25-20 ESNA
24	5093006	4	CLAMP
25	970029	17	BOLT HEXHD .25-20 X .75 GR5
26	986019	12	WASHER FLAT .25
27	987099	14	WASHER LOCK .25 MDM
28	970239	2	BOLT HEXHD .313-18 X .75 GR5
29	986269	2	WASHER FLAT .313
30	987109	4	WASHER LOCK .313 MDM
33	0082046	1	ACTUATOR MODULE (WITH ENGINE)
35	974659	2	SCREW RHD #10-24 X .50 PLATED
36	5560365	5	WASHER LOCK #10
37	0112744	1	WIRING BOX SUB ASSEMBLY
39	0112788	1	TURNTABLE WIRE ASSEMBLY
40	3040534	1	PDM MODULE
41		2	M. SCREW #6-32 X 1 LG TRUSS HD
42	5560664	4	WASHER #6 MEDIUM LOCK
43	5560629	4	WASHER #6 FLAT
44	984009	4	NUT #6-32 HEX
45	3044146	4	TERM, #10 STUD INS 22/18 WIRE
46	3040046	6	TERM, .250 MALE SLIP-ON F.I. 22/18 WIRE
47	3040127	1	HORN
48		4	CAPSCREW 1/4-20 X 1 LG HH
51	0071545	1	JUMPER WIRE
52	3040082	2	TERM, .250 MALE SLIP ON F.I. 16/14 WIRE
53	3044162	1	TERM, 1/4 STUD INS. 16/14 WIRE
59	3040122	1	EPS/ANTI-RESTART MODULE
60	974239	2	SCREW RHD #6-32 .50
61	0075268	2	WIRE 2/0 R375 R375 13 BLK

## Turntable Electrical, Cummins – TB85J



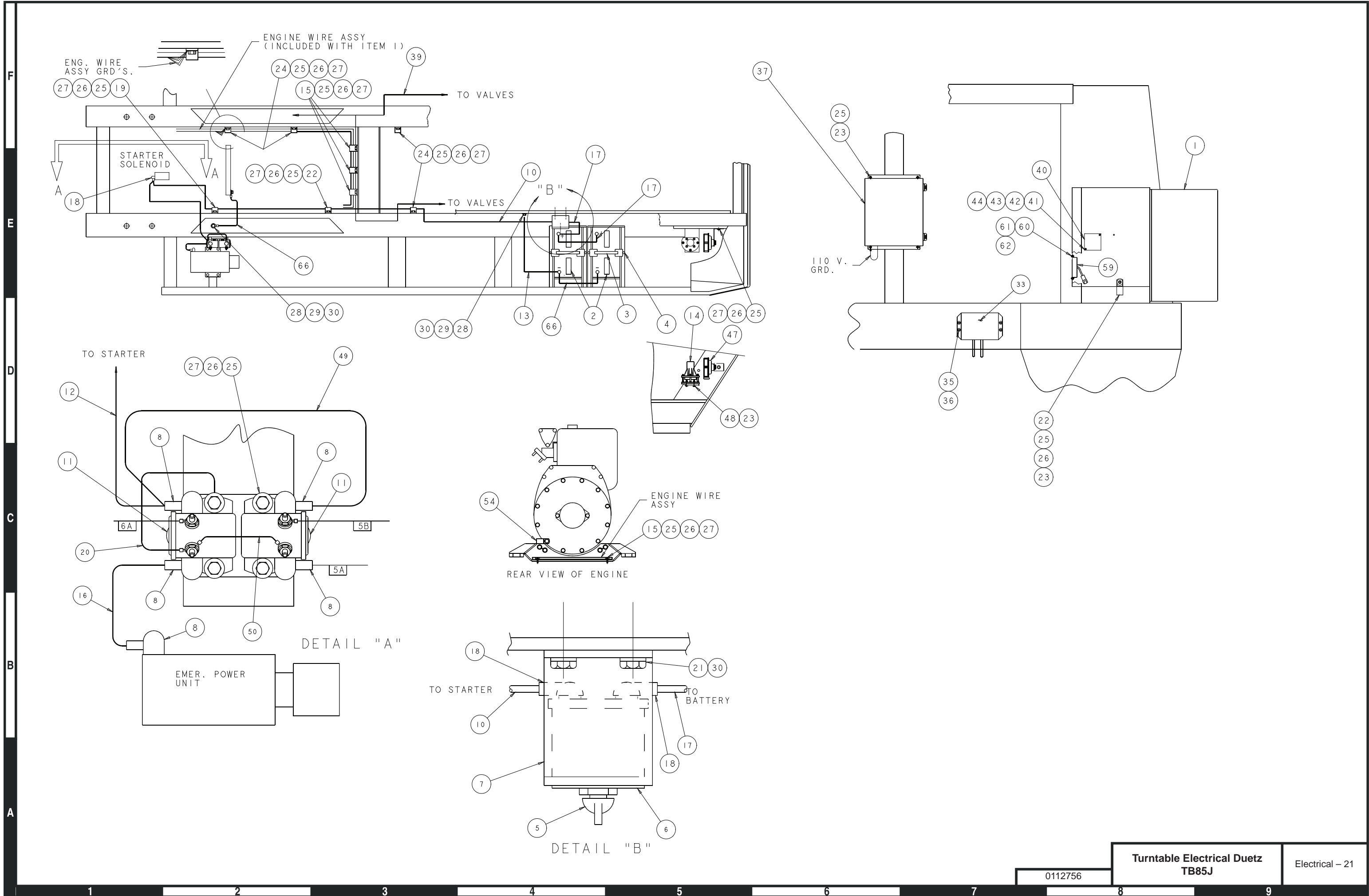

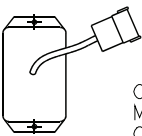
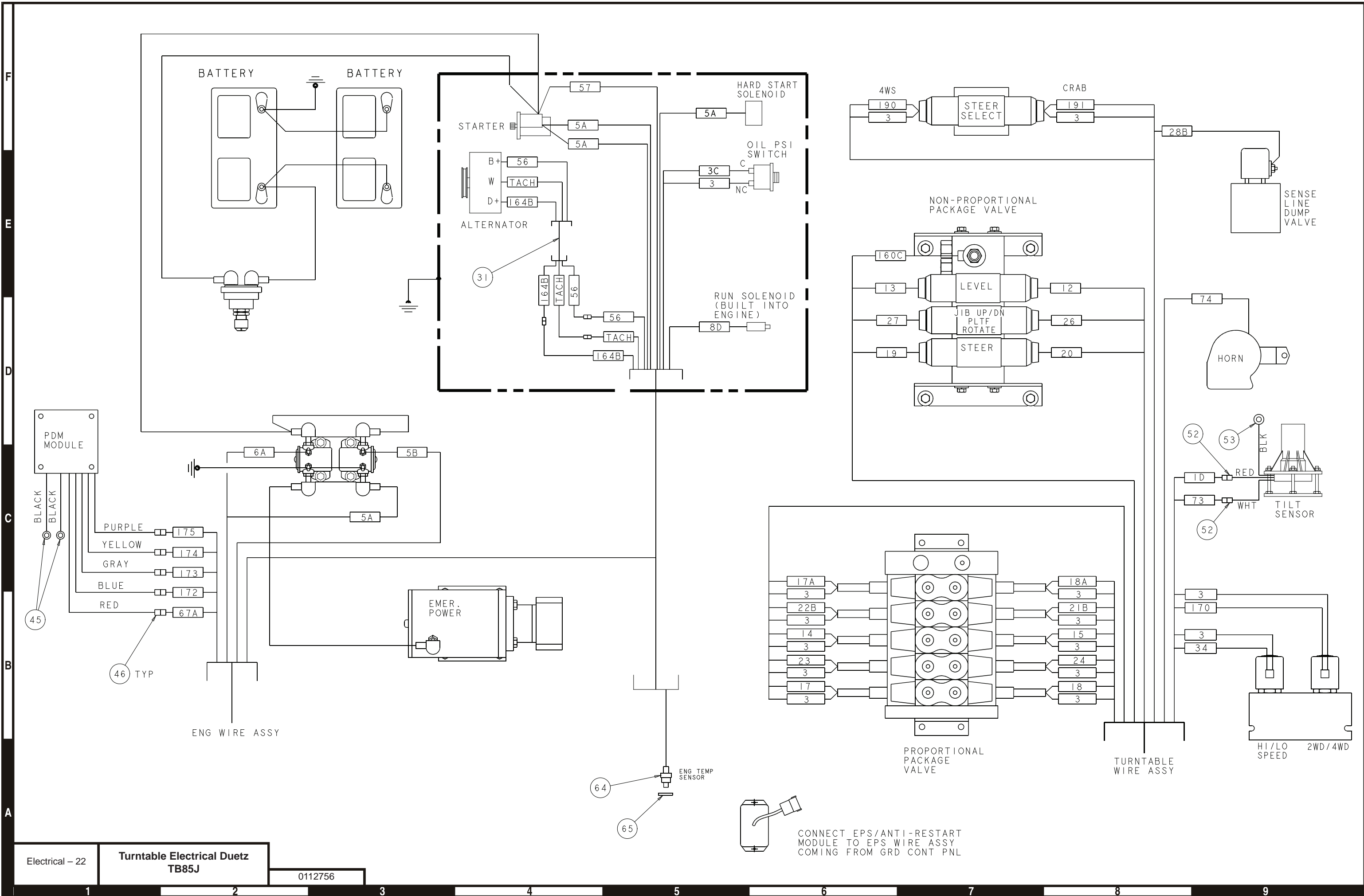

CONNECT EPS/ANTI-RESTART  
MODULE TO EPS WIRE ASSY  
COMING FROM GRD CONT PNL

F  
E  
D  
C  
B  
A

1 2 3 4 5 6 7 8 9



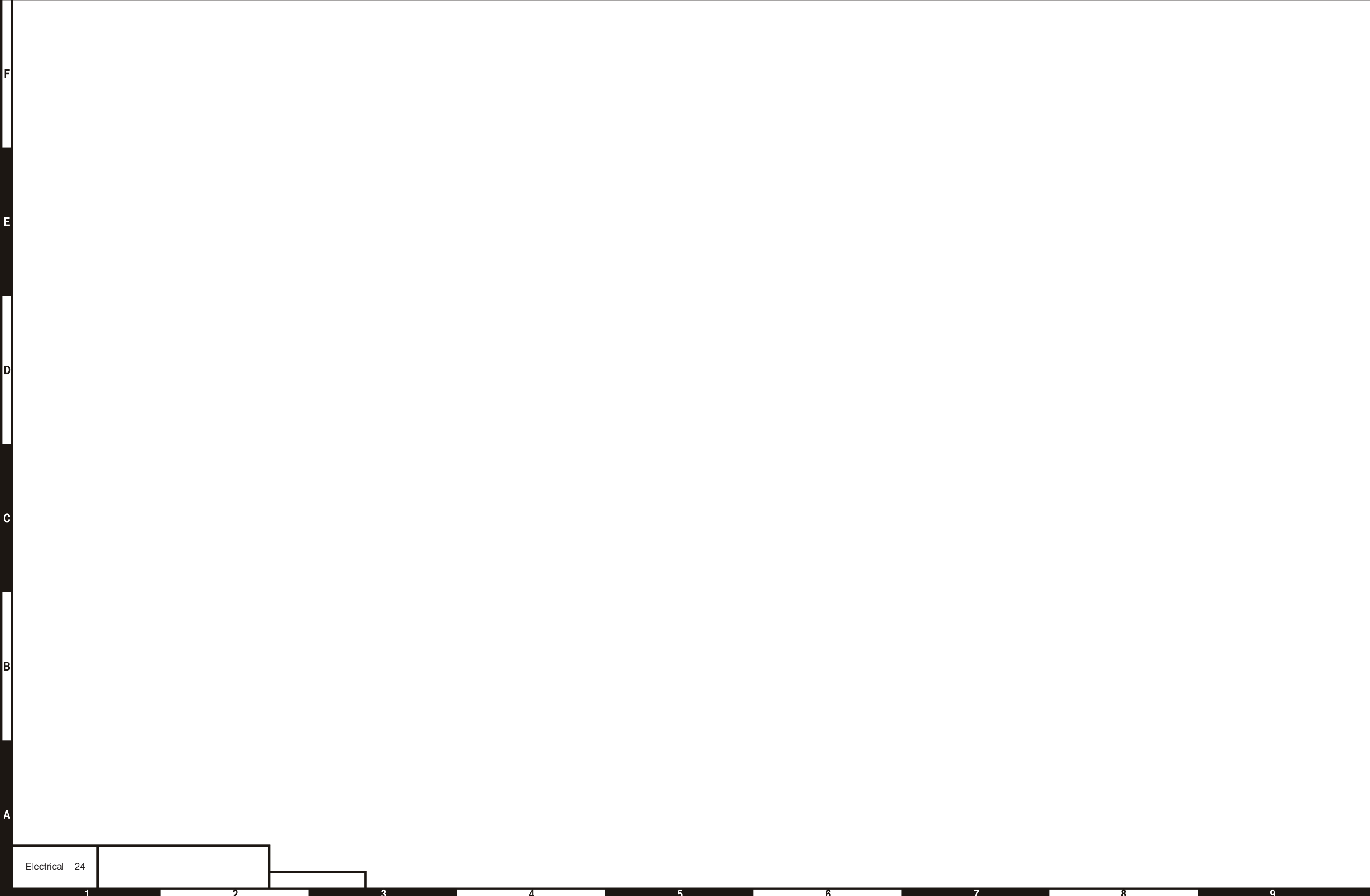

F

E

D

C

B

A

Electrical - 24

1

2

3

4

5

6

7

8

9



## Turntable Electrical, Deutz – TB85J

Item	Part No.	Qty.	Description
1	0112758	1	GROUND CONTROL PANEL ASSEMBLY
2	3050002	2	BATTERY
3	3050008	2	BATTERY HOLDDOWN
4	3050004	4	BATTERY HOLDDOWN BOLT
5	3020049	1	SWITCH, BATTERY DISCONNECT
6	0073089	1	PLACARD
7	0073051	1	BRACKET, BATTERY DISCONNECT
8	3040268	5	BOOT
10	0110529	1	BATTERY WIRE
11	6040506	2	SOLENOID
12	0151160	1	BATTERY WIRE
13	0080483	1	BATTERY WIRE
14	3020040	1	TILT ALARM SENSOR
15	5093000	5	CLAMP
16	0072323	1	BATTERY WIRE
17	0080484	2	WIRE 2/0 R375 R375 13 RED
18	3040269	3	BOOT
19	5093027	1	CLAMP
20	0071568	1	JUMPER WIRE
21	970249	2	BOLT HEXHD .313-18 .875 GR5
22	5093008	2	CLAMP
23	5560004	7	NUT LKG .250-20
24	5093006	4	CLAMP
25	970029	20	BOLT HEXHD .250-20 .75 GR5
26	986019	17	WASHER FLAT .250
27	987009	16	WASHER LOCK .250 MDM
28	970239	2	BOLT HEXHD .313-18 .75 GR5
29	986269	2	WASHER FLAT .313
30	987109	4	WASHER LOCK .313 MDM
31	0074579	1	ALTERNATOR HARNESS
33	0082046	1	ACTUATOR MODULE (WITH ENGINE)
35	974689	4	SCREW RDHD #10-24 .75 PLATED
36	5560654	4	WASHER LOCK #10 PLATED
37	0112744	1	WIRING BOX SUB ASSEMBLY
39	0112788	1	TURNTABLE WIRE ASSEMBLY
40	3040534	1	PDM MODULE
41		2	SCREW TRUSS HD #6-32 1.00 PLATED
42	5560664	4	WASHER LOCK #6 MDM
43	986159	4	WASHER FLAT #6
44	984009	4	NUT HEX #6-32
45	3044146	6	TERM, #10 STUD, INS 22/18 WIRE
46	3040046	5	TERM, .250 MALE SLIP-ON F.I. 22/18 WIRE
47	3040127	1	HORN
48	970049	4	BOLT HEXHD .250-20 1.00 GR5
49	0151919	1	JUMPER WIRE
50	0151371	1	JUMPER WIRE
51	0071545	1	JUMPER WIRE
52	3040082	5	TERM, .250 MALE SLIP-ON F.I. 16/14
53	3044162	1	TERM, 1/4 STUD INS. 16/14 WIRE
54	5093010	1	CLAMP
59	3030122	1	ENGINE PROTECTION MODULE HIGH
60	974239	2	SCREW RHD #6-32 .50
61	984009	2	NUT HEX 6-32 PLATED
62	986159	2	WASHER FLAT #6
64	3070039	1	TEMP SENSOR M18 X 1.5 HIGH
65	5569837	1	WASHER FLAT M18 COPPER
66	0075268	2	WIRE 2/0 R375 R375 13 BLACK

## Turntable Electrical, Deutz – TB85J



F  
E  
D  
C  
B  
A

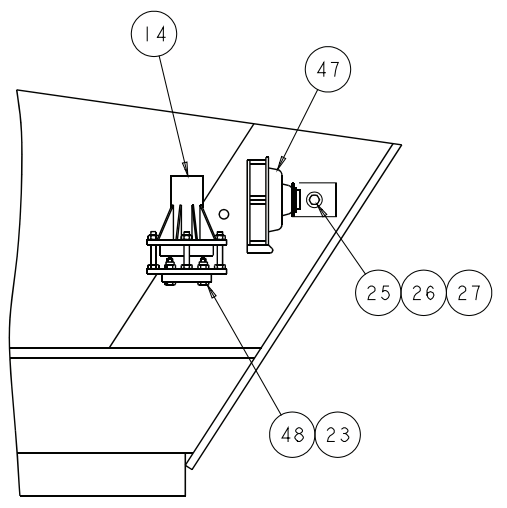
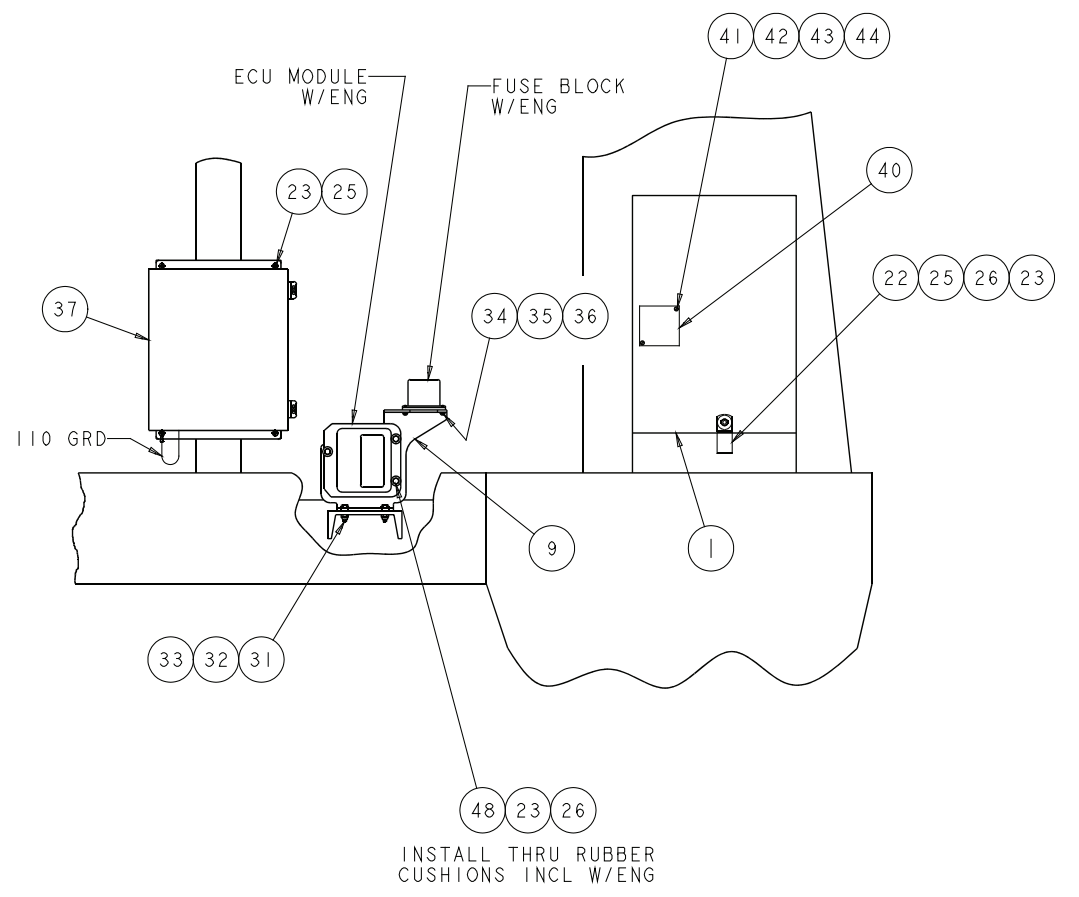
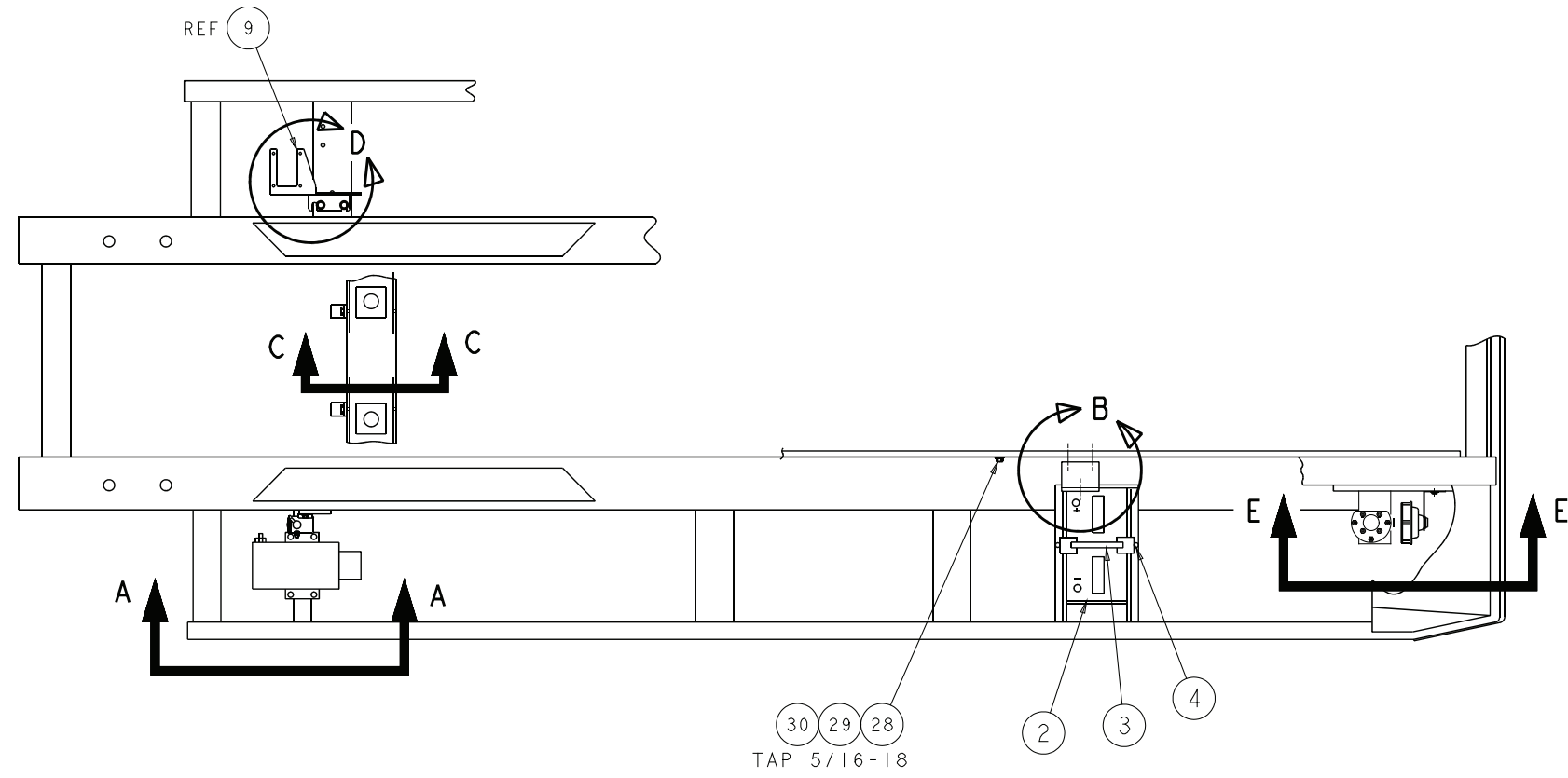

VIEW "E"

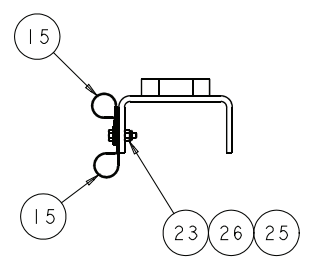

VIEW C-C

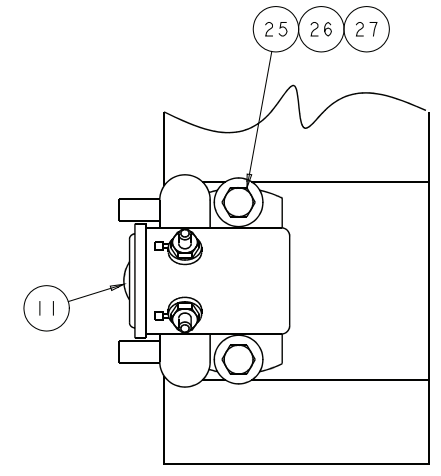

VIEW "A"

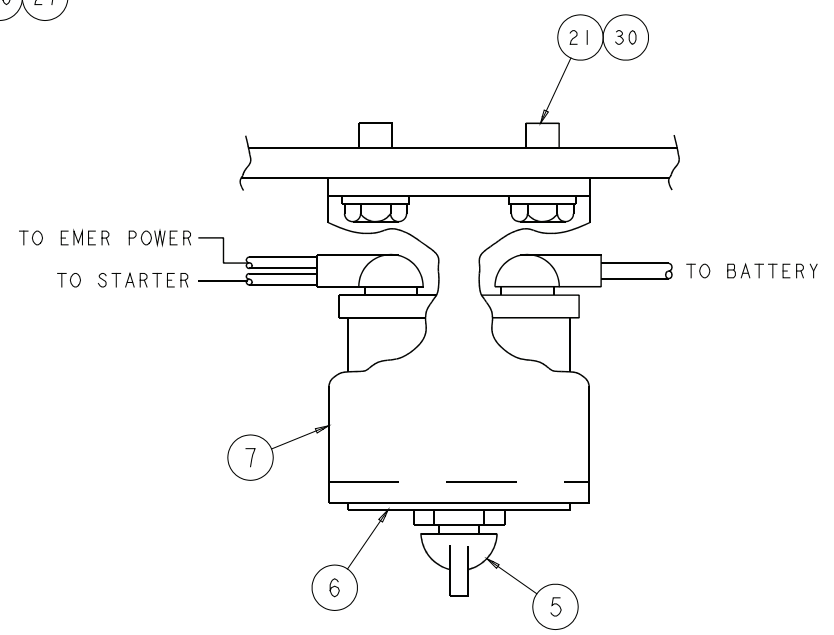

DETAIL "B"

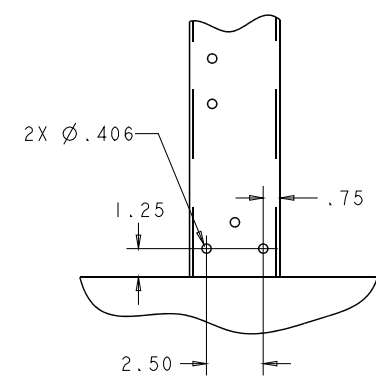

DETAIL "D"

1 2 3 4 5 6 7 8 9

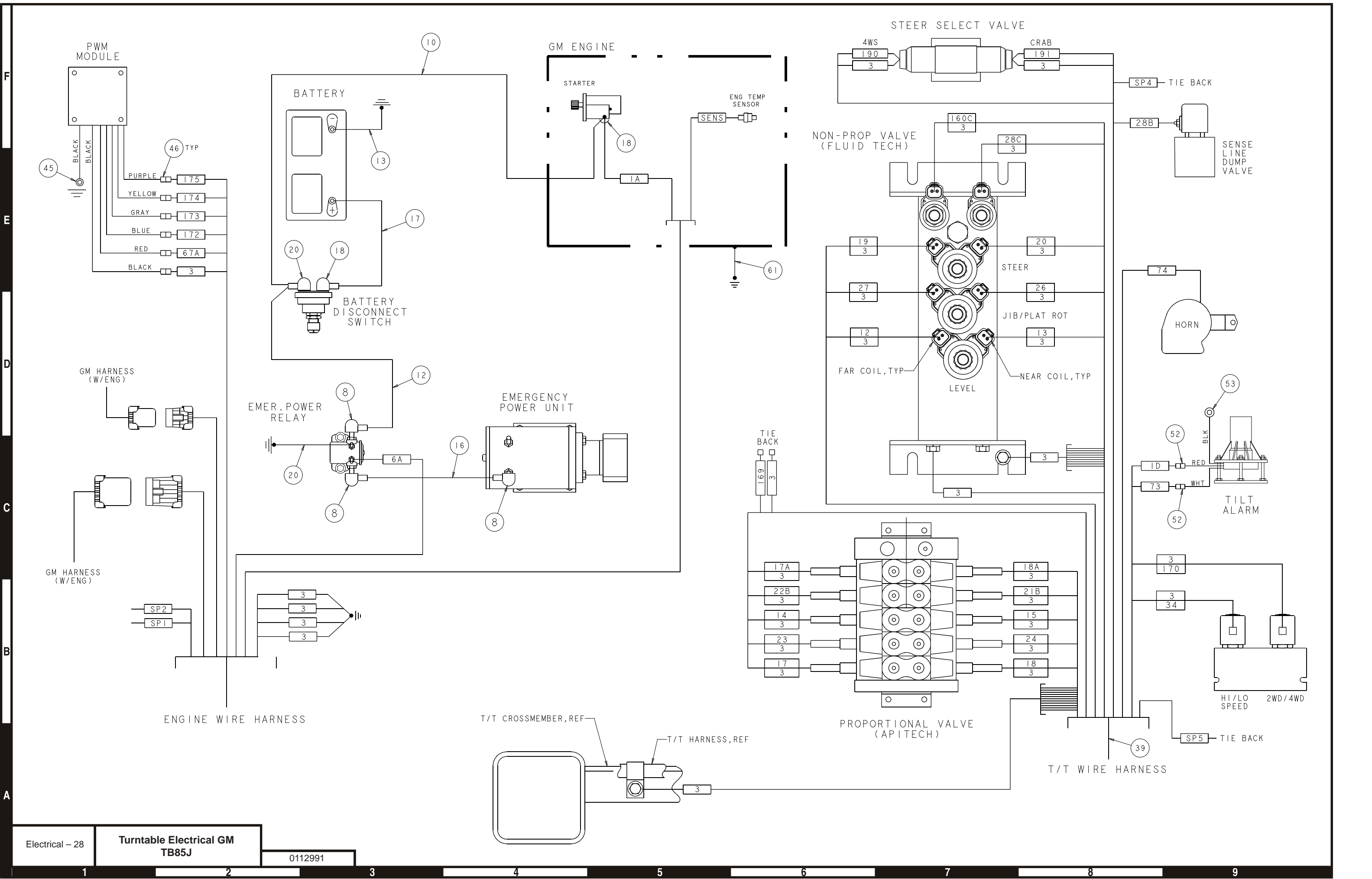

F  
E  
D  
C  
B  
A

1      2      3      4      5      6      7      8      9

F

E

D

C

B

A

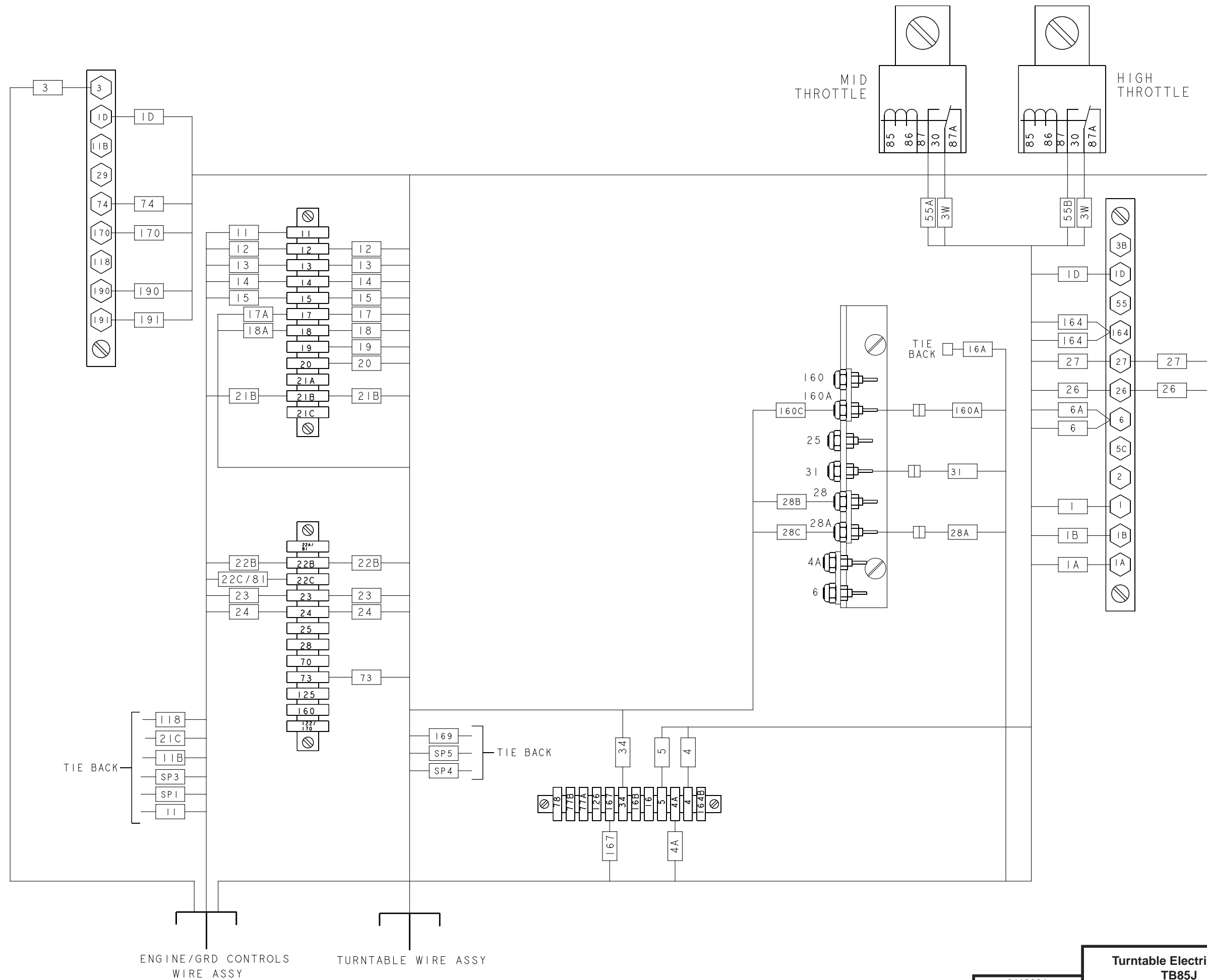

ENGINE/GRD CONTROLS  
WIRE ASSY

TURNTABLE WIRE ASSY

Turntable Electrical GM  
TB85J

Electrical - 29

0112991

1

2

3

4

5

6

7

8

9

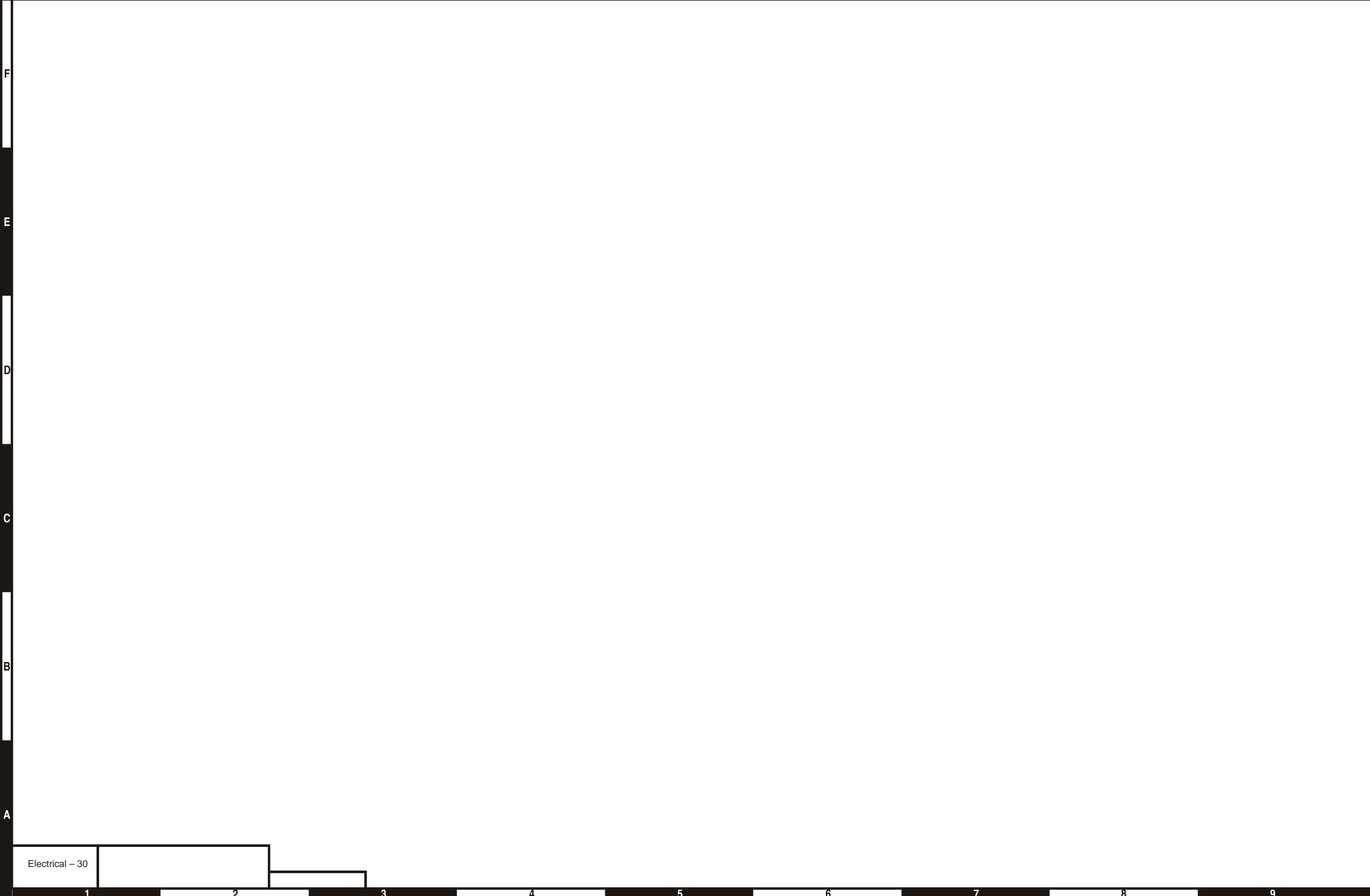

F

E

D

C

B

A

1

2

3

4

5

6

7

8

9

Electrical - 30

## Turntable Electrical, GM – TB85J

Item	Part No.	Qty.	Description
1	0112992	1	GROUND CONTROL PANEL ASSEMBLY
2	3050002	2	BATTERY
3	3050008	2	BATTERY HOLDDOWN
4	3050004	4	BATTERY HOLDDOWN BOLT
5	3020049	1	SWITCH, BATTERY DISCONNECT
6	0073089	1	PLACARD
7	0073051	1	BRACKET, BATTERY DISCONNECT
8	3040268	5	BOOT
9	0182184	1	BRACKET, ECU/FUSE BLK MNTG
10	0110529	1	BATTERY WIRE
11	6040506	2	SOLENOID
12	0070705	1	BATTERY WIRE
13	0080483	1	BATTERY WIRE
14	3020040	1	TILT ALARM SENSOR
15	5093004	5	CLAMP
16	0072323	1	BATTERY WIRE
17	0080484	2	WIRE 2/0 R375 R375 13 RED
18	3040269	3	BOOT
19	5093027	1	CLAMP
20	3040270	1	BOOT BATTERY CABLE END Y-TYPE
21	970249	2	BOLT HEXHD .313-18 .875 GR5
22	5093008	2	CLAMP
23	5560004	7	NUT LKG .250-20
24	5093006	4	CLAMP
25	970029	17	BOLT HEXHD .250-20 .75 GR5
26	986019	15	WASHER FLAT .250
27	987009	14	WASHER LOCK .250 MDM
28	970239	2	BOLT HEXHD .313-18 .75 GR5
29	986269	2	WASHER FLAT .313
30	987109	4	WASHER LOCK .313 MDM
31	970419	2	BOLT HEXHD .375-16 X 1.25 GR5
32	986299	2	WASHER FLAT .375
33	5560003	2	NUT LKG .375-16
34		4	SCREW RDH #10-32 X .75
35	986009	4	WASHER FLAT #10
36	5560654	4	WASHER LOCK #10
37	0112994	1	WIRING BOX SUB ASSEMBLY
39	0112993	1	TURNTABLE WIRE ASSEMBLY
40	3040534	1	PDM MODULE
41		2	SCREW TRUSS HD #6-32 1.00 PLATED
42	5560664	4	WASHER LOCK #6 MDM
43	986159	4	WASHER FLAT #6
44	984009	4	NUT HEX #6-32
45	3044146	6	TERM, #10 STUD, INS 22/18 WIRE
46	3040046	5	TERM, .250 MALE SLIP-ON F.I. 22/18 WIRE
47	3040127	1	HORN
48	970049	4	BOLT HEXHD .250-20 1.00 GR5
51	0071545	1	JUMPER WIRE
52	3040082	2	TERM, .250 MALE SLIP-ON F.I. 16/14
53	3044162	1	TERM, 1/4 STUD INS. 16/14 WIRE
60	974239	2	SCREW RHD #6-32 .50
61	0075268	2	WIRE 2/0 R375 R375 13 BLACKD

## Turntable Electrical, GM – TB85J





F

E

D

C

B

A

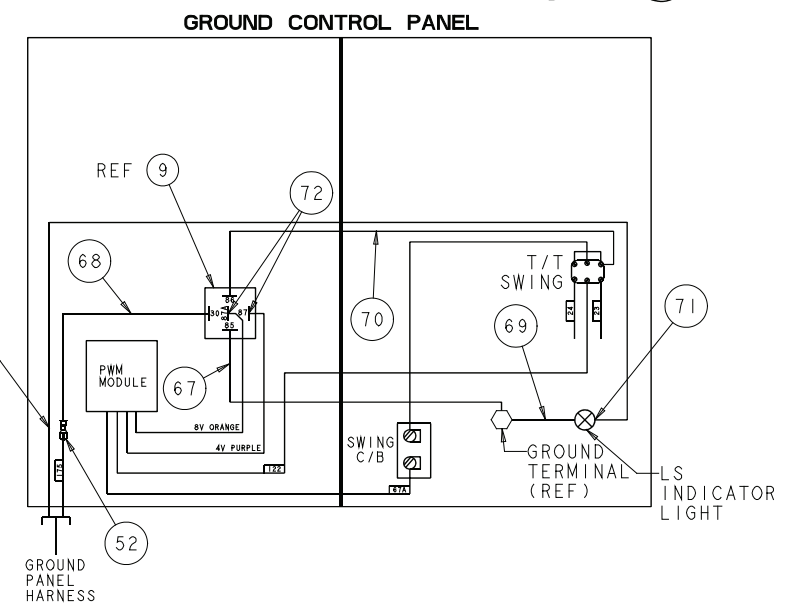
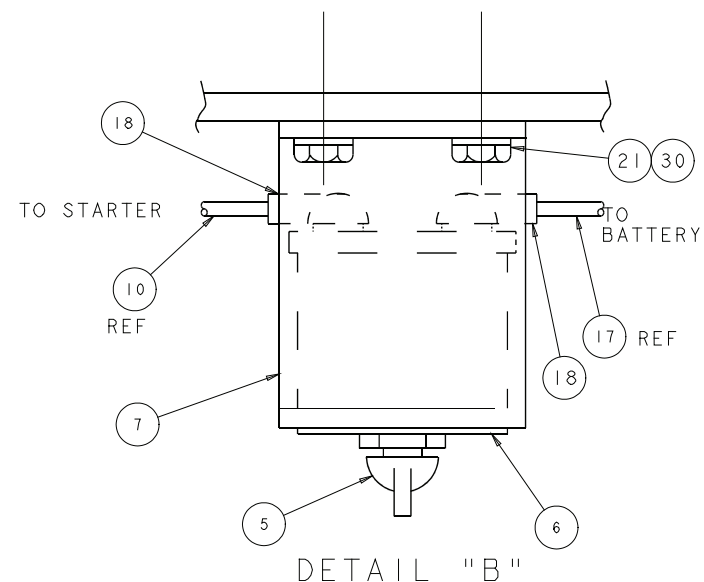
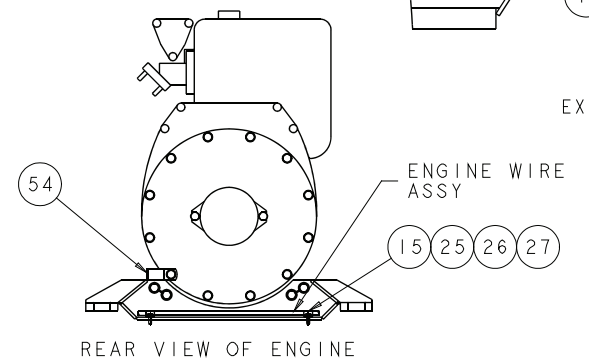
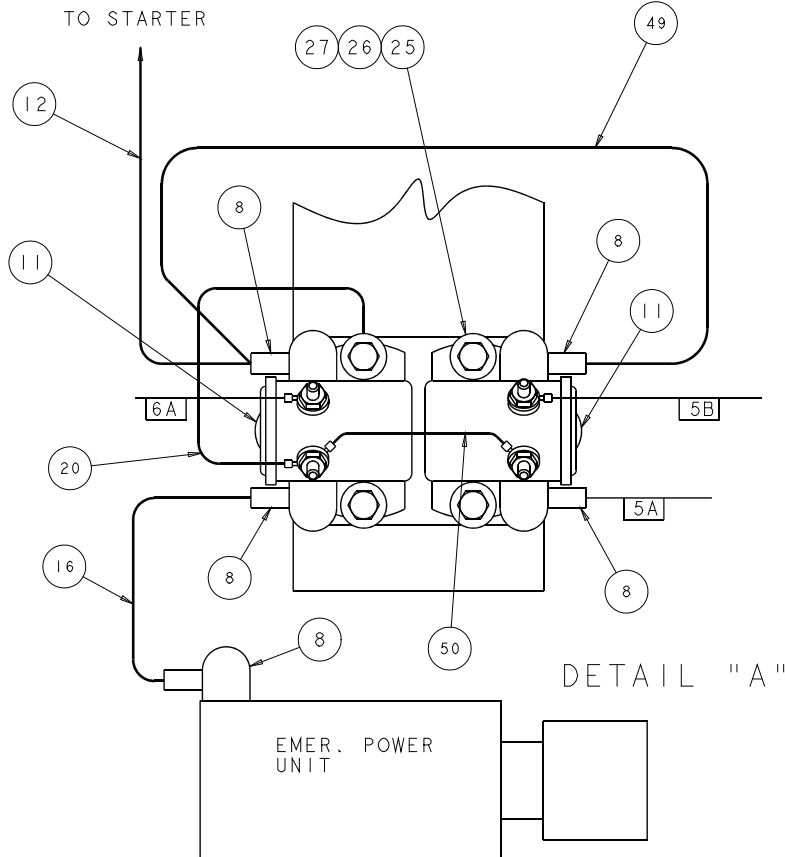
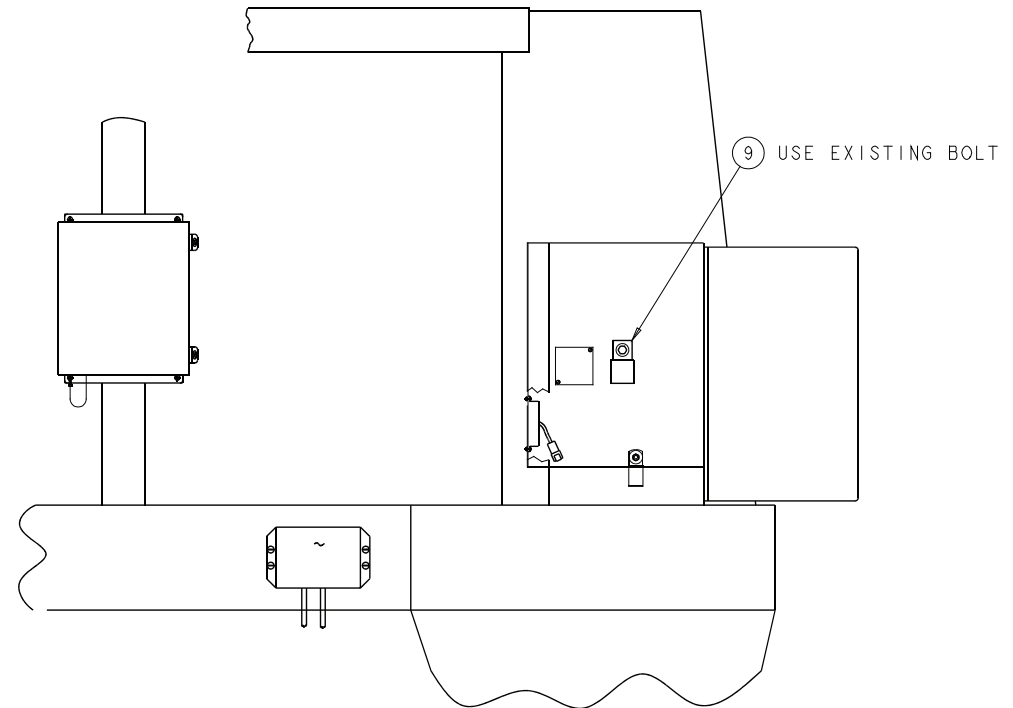
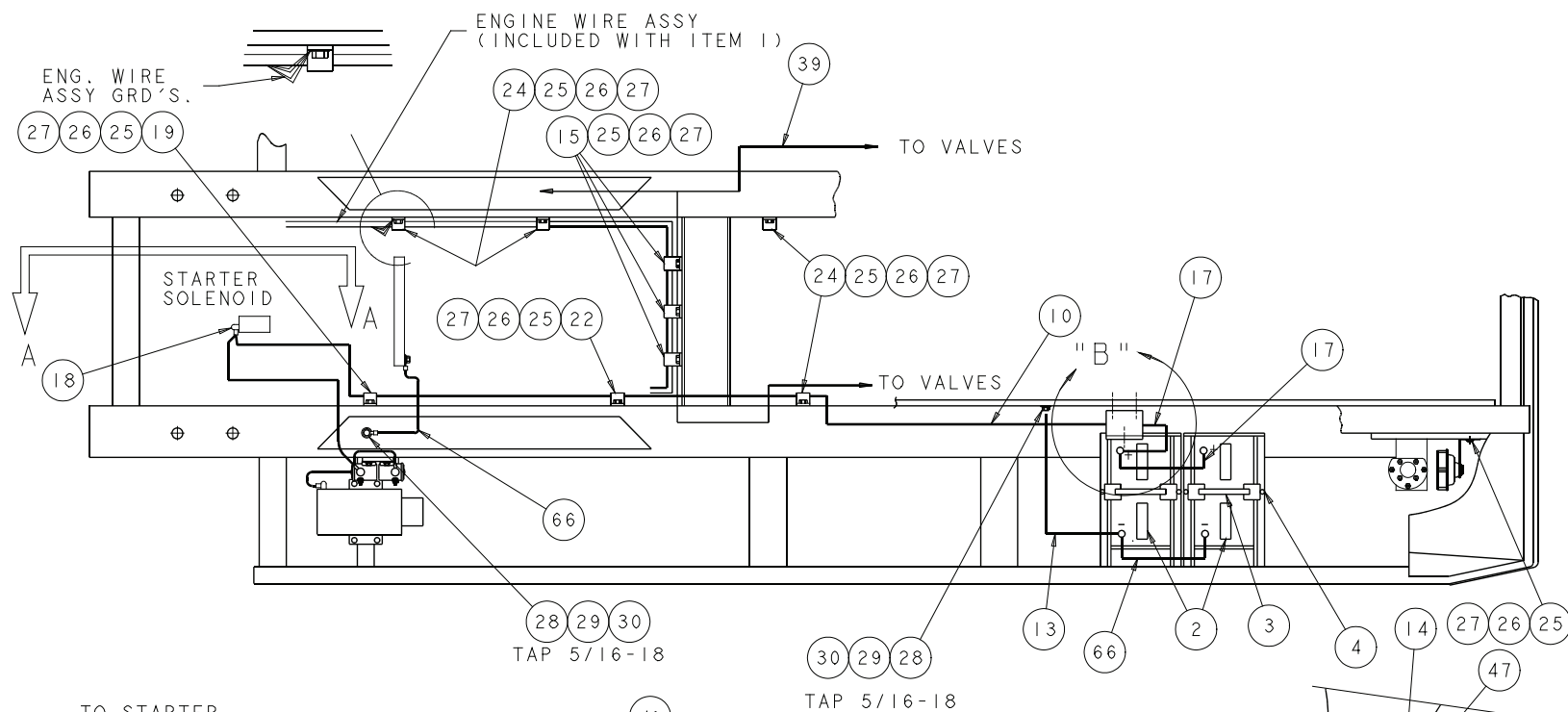

F

E

D

C

B

A

BATTERY BATTERY

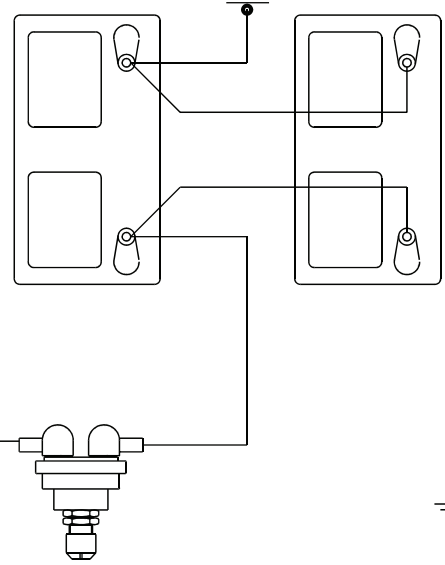

STARTER

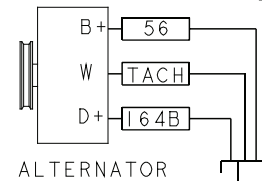

ALTERNATOR

31

HARD START SOLENOID

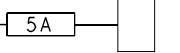

OIL PSI SWITCH

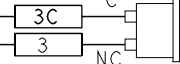

RUN SOLENOID (BUILT INTO ENGINE)

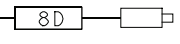

NON-PROPORTIONAL PACKAGE VALVE

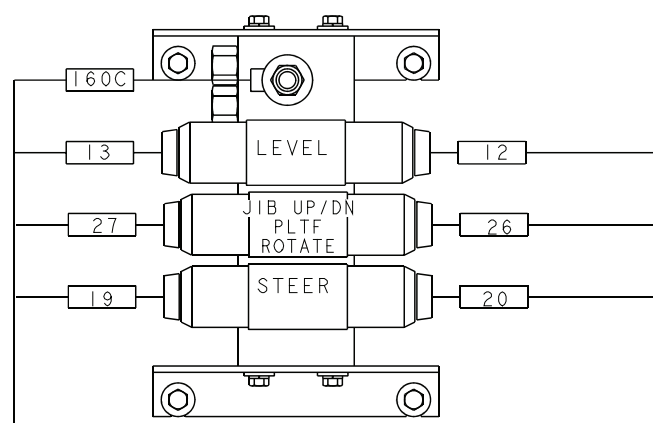

SENSE LINE DUMP VALVE

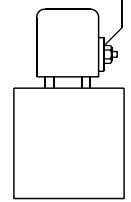

HORN

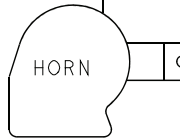

TILT SENSOR

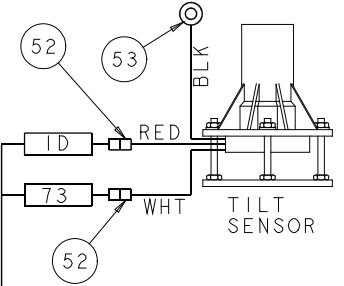

PROPORTIONAL PACKAGE VALVE

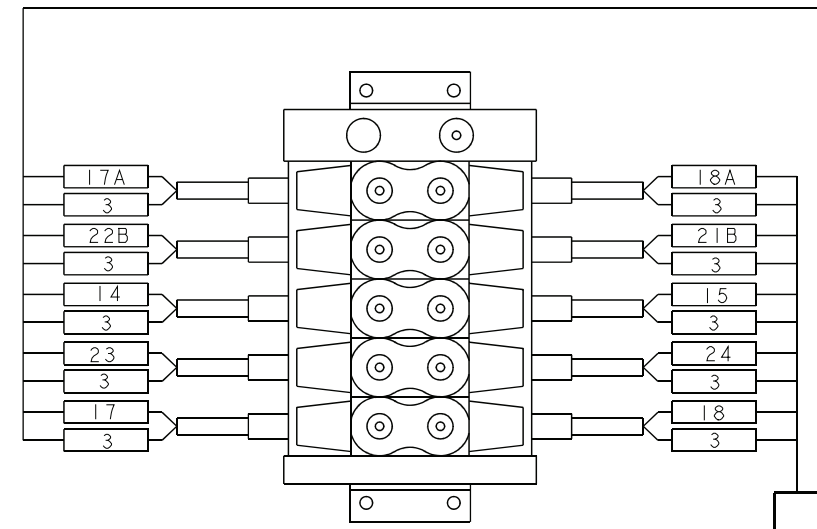

TURNTABLE WIRE ASSY

HI/LO SPEED 2WD/4WD

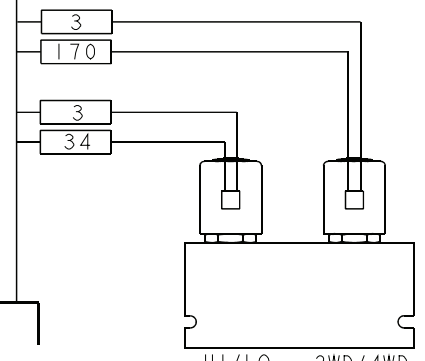

PDM MODULE

SEE SHEET 1 FOR WIRING

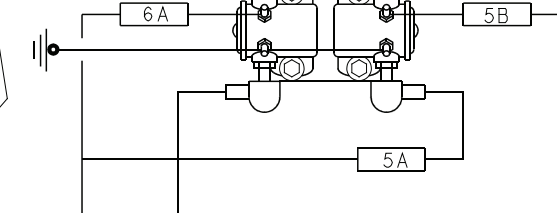
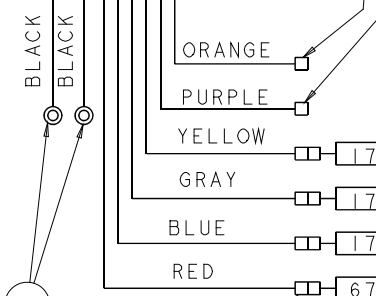

EMER. POWER

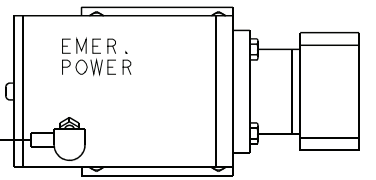

ENG WIRE ASSY

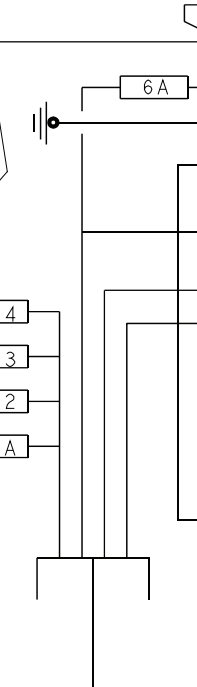

ENG TEMP SENSOR

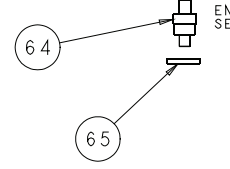

CONNECT EPS/ANTI-RESTART MODULE TO EPS WIRE ASSY COMING FROM GRD CONT PNL

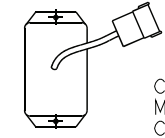

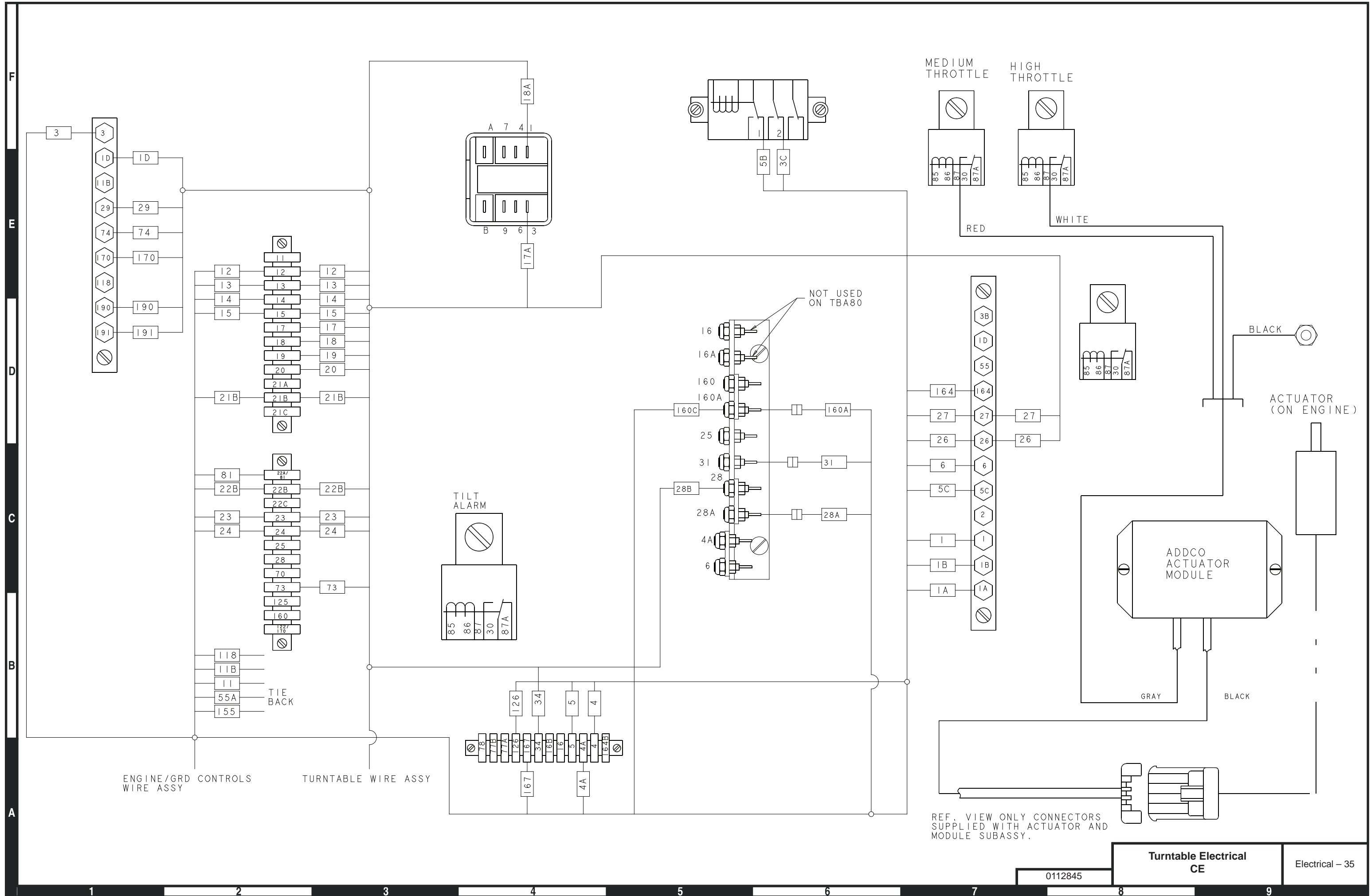

ENGINE/GRD CONTROLS WIRE ASSY

TURNTABLE WIRE ASSY

TILT ALARM

REF. VIEW ONLY CONNECTORS SUPPLIED WITH ACTUATOR AND MODULE SUBASSY.

Turntable Electrical  
CE

Electrical - 35

0112845

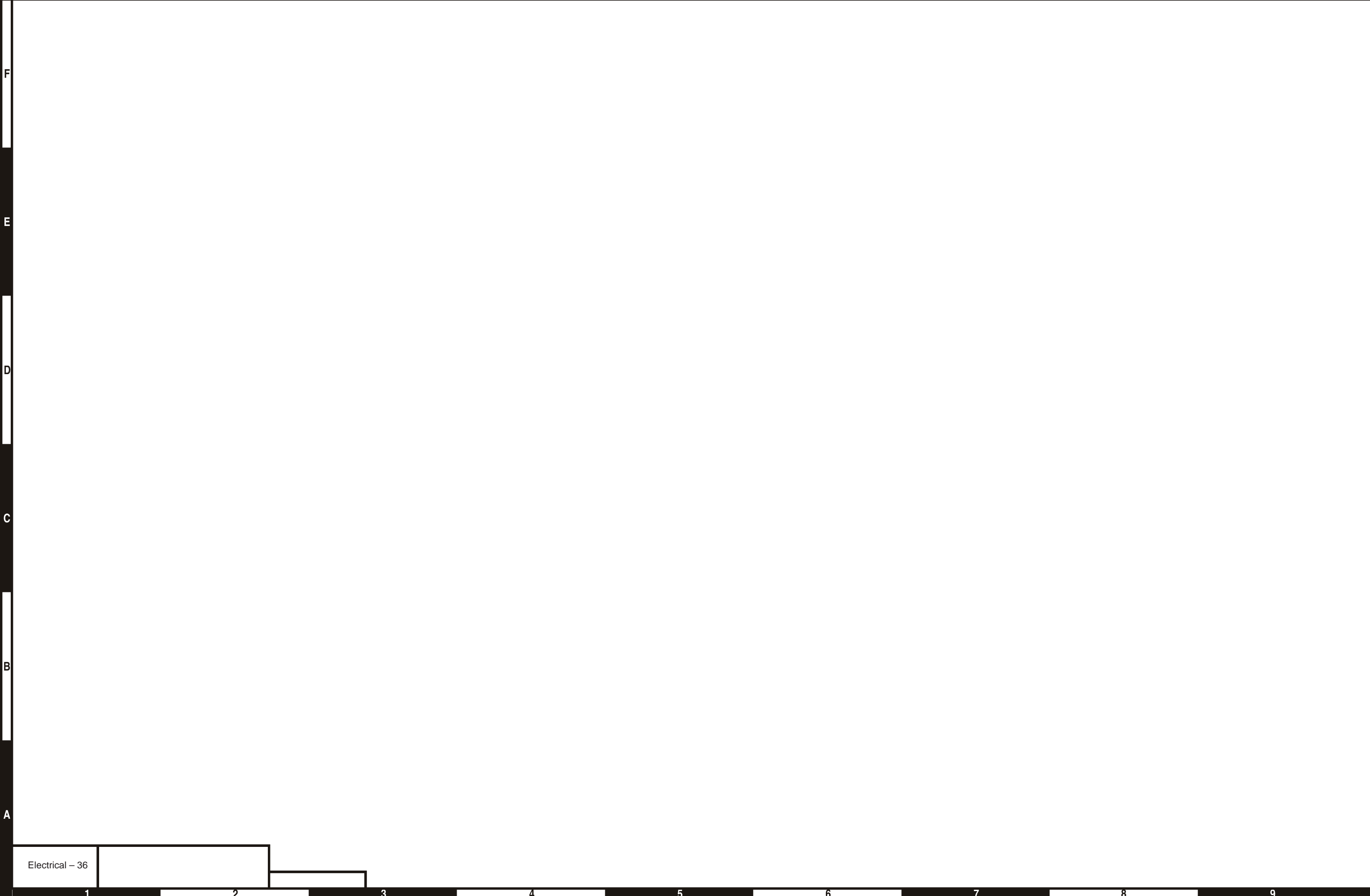

F

E

D

C

B

A

Electrical - 36

1

2

3

4

5

6

7

8

9

## Turntable Electrical – CE

Item	Part No.	Qty.	Description
1	0112846	1	GROUND CONTROL PANEL ASSEMBLY
2	3050002	2	BATTERY
3	3050008	2	BATTERY HOLDDOWN
4	3050004	4	BATTERY HOLDDOWN BOLT
5	3040049	1	SWITCH, BATTERY DISCONNECT
6	0073089	1	PLACARD
7	0073051	1	BRACKET, BATTERY DISCONNECT
8	3040268	3	BOOT
9	3040469	1	RELAY SPDT 12V 30AMP
10	0110529	1	BATTERY WIRE
11	3040506	1	SOLENOID
12	0151160	1	BATTERY WIRE
13	0080483	1	BATTERY WIRE
14	3020103	1	TILT ALARM SENSOR
15	5093000	3	CLAMP
16	0072323	1	BATTERY WIRE
17	0080484	2	WIRE 2/0 R375 R375 13 RED
18	3040269	2	BOOT
19	5093027	1	CLAMP
20	0071568	1	JUMPER WIRE
21	970249	2	BOLT HEXHD .313-18 X .88 GR5
22	5093008	3	CLAMP
23	5560004	9	NUT LKG .25-20 ESNA
24	5093006	4	CLAMP
25	970029	20	BOLT HEXHD .25-20 X .75 GR5
26	986019	17	WASHER FLAT .25
27	987099	16	WASHER LOCK .25 MDM
28	970239	2	BOLT HEXHD .313-18 X .75 GR5
29	986269	2	WASHER FLAT .313
30	987109	4	WASHER LOCK .313 MDM
31	0074579	1	ALTERNATOR HARNESS
33	0082046	1	ACTUATOR MODULE (WITH ENGINE)
35	974659	4	SCREW RHD #10-24 X .50 PLATED
36	5560365	4	WASHER LOCK #10
37	0112744	1	WIRING BOX SUB ASSEMBLY
39	0112788	1	TURNTABLE WIRE ASSEMBLY
40	3040534	1	PDM MODULE
41		2	M. SCREW #6-32 X 1 LG TRUSS HD
42	5560664	4	WASHER #6 MEDIUM LOCK
43	5560629	4	WASHER #6 FLAT
44	984009	4	NUT #6-32 HEX
45	3044146	2	TERM, #10 STUD INS 22/18 WIRE
46	3040046	4	TERM, .250 MALE SLIP-ON F.I. 22/18 WIRE
47	3040127	1	HORN
48		4	CAPSCREW 1/4-20 X 1 LG HH
49	0151919	1	JUMPER WIRE
50	0151371	1	JUMPER WIRE
51	0071545	1	JUMPER WIRE
52	3040082	3	TERM, .250 MALE SLIP ON F.I. 16/14 WIRE
53	3044162	1	TERM, 1/4 STUD INS. 16/14 WIRE
59	3040122	1	EPS/ANTI-RESTART MODULE
60	974239	2	SCREW RHD #6-32 .50
61	0075268	2	WIRE 2/0 R375 R375 13 BLK
62	986159	2	WASHER, FLAT #6
64	3070039	1	TEMP SENSOR M18 X 1.5 HIGH
65	5569837	1	WASHER FLAT M18 COPPER
66	0075268	2	WIRE 2/0 R375 R375 13 BLK
67	0071556	1	WIRE 16 R101 FEM250I 24
68	0073642	1	WIRE 16 FEM250I FEM250I 10

## Turntable Electrical – CE

## Turntable Electrical – CE

Item	Part No.	Qty.	Description
69	0071534	1	WIRE 18 R101 FEM188I 21
70	0073071	1	WIRE 18 R61 FEM 250F1 28
71	3046972	1	TERM FEM188I 22/18
72	3040047	2	TERM FEM250I 22/18

## Turntable Electrical – CE

F

E

D

C

B

A

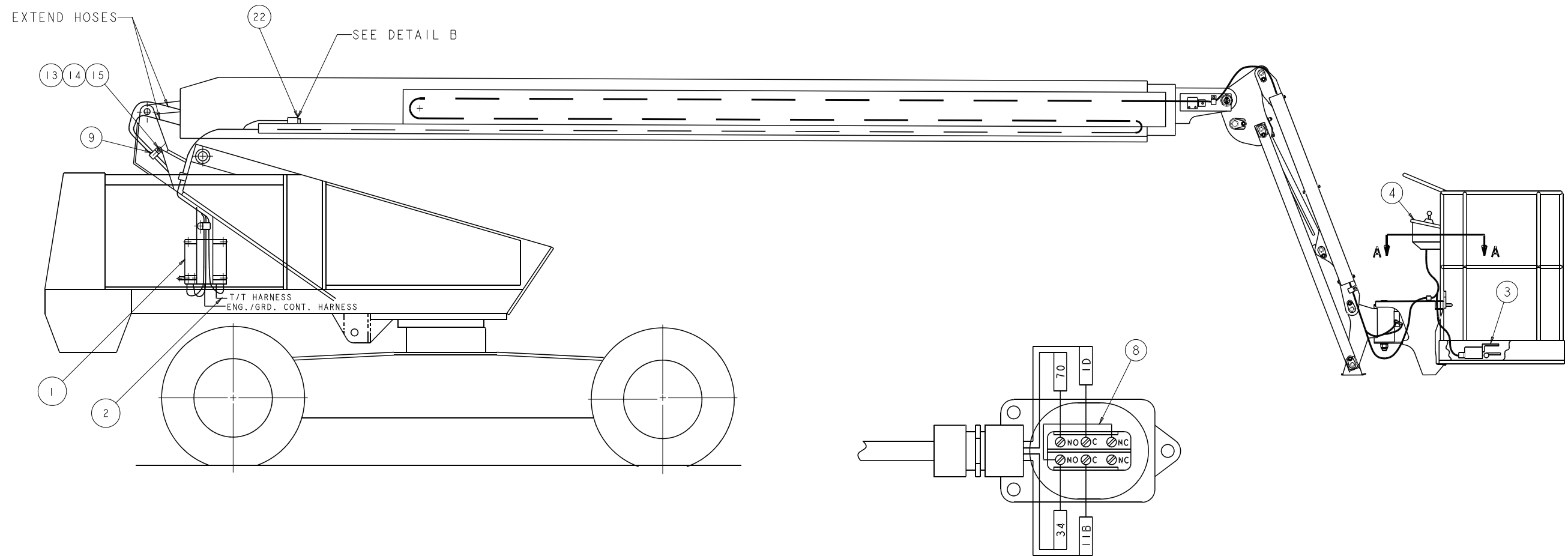
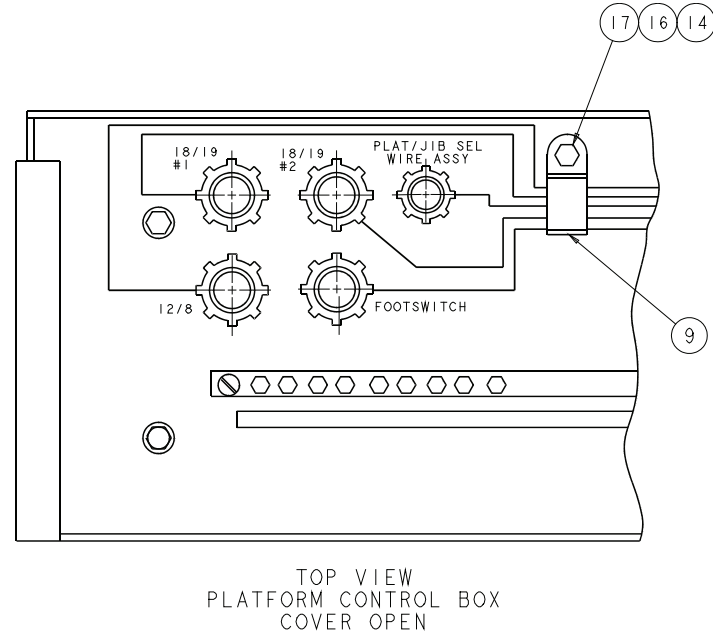
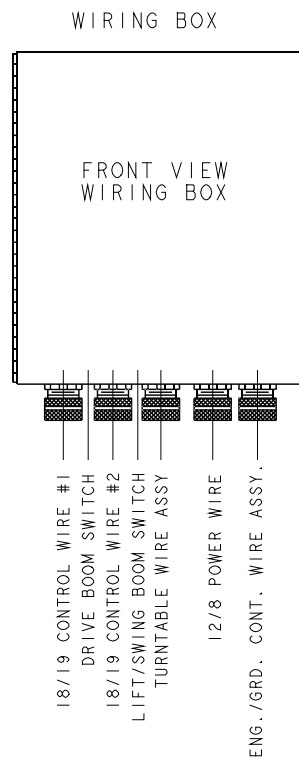

F  
E  
D  
C  
B  
A

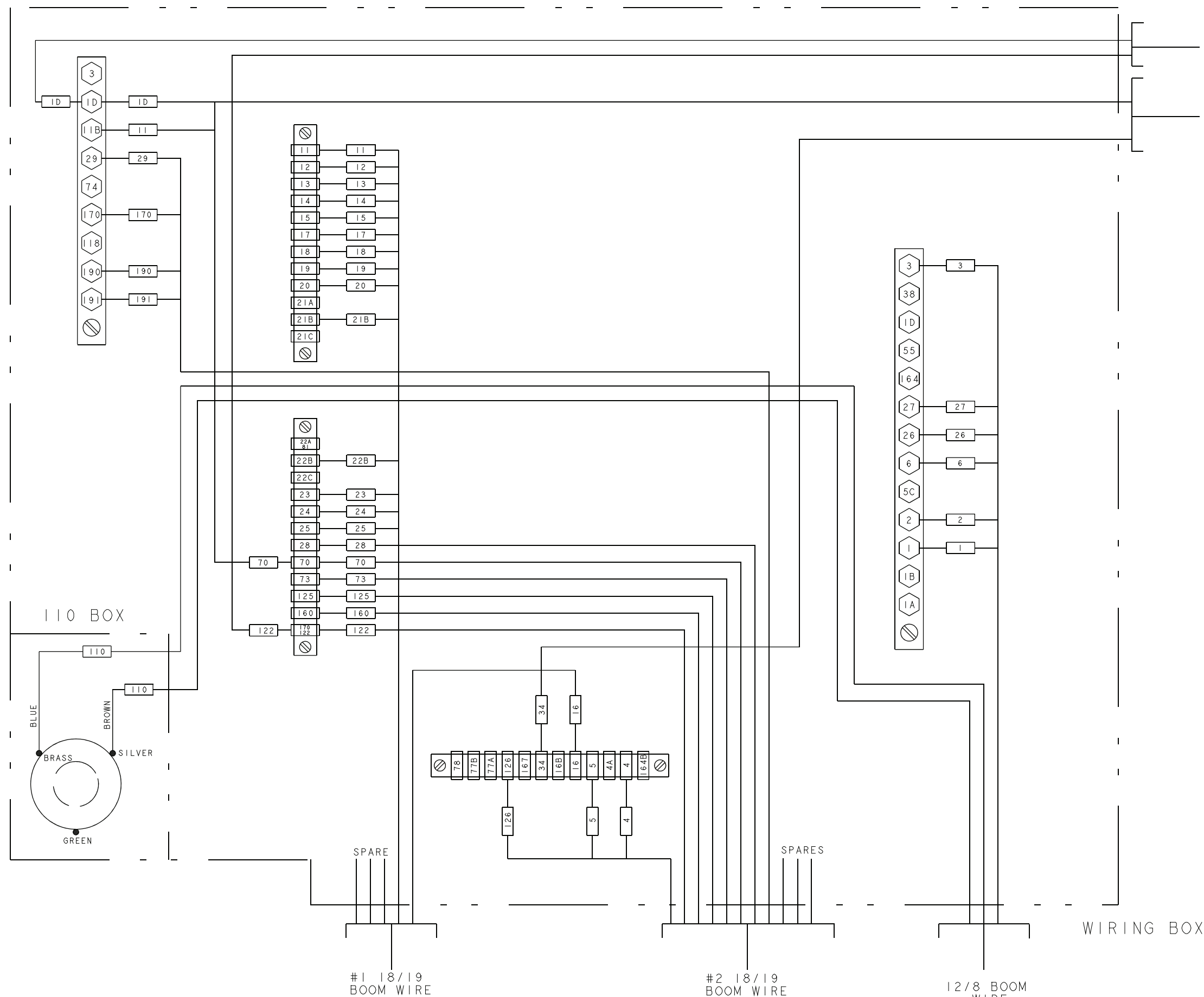

18/19 #1 CONDUCTOR WIRE				
SNORKEL WIRE NO.	DESCRIPTION	B. REX WIRE NO.	BRAND REX WIRE COLOR	TERMINAL WIRING BOX
11	RANGE (LOW MOTOR SPD)	12	BLACK/RED	ITEM 6
12	LEVEL - DOWN	13	BLUE/RED	ITEM 6
13	LEVEL - UP	14	ORANGE/RED	ITEM 6
14	BOOM - EXTEND	15	YELLOW/RED	ITEM 6
15	BOOM - RETRACT	6	BROWN	ITEM 6
16	HYD. SPEED	3	BLUE	ITEM 6
17	DRIVE - FORWARD	4	ORANGE	ITEM 6
18	DRIVE - REVERSE	10	YELLOW/BLACK	ITEM 6
19	STEER - LEFT	16	BROWN/RED	ITEM 6
20	STEER - RIGHT	8	BLUE/BLACK	ITEM 6
21B	MAIN BOOM DOWN	19	ORANGE/BLUE	ITEM 6
---	SPARE	18	RED/BLUE	---
22B	MAIN BOOM UP	7	RED/BLACK	ITEM 6
---	SPARE	9	ORANGE/BLACK	---
23	SWING - CCW	17	BLACK/BLUE	ITEM 6
24	SWING - CW	11	BROWN/BLACK	ITEM 6
25	THROTTLE - MED.	1	BLACK	ITEM 6
---	SPARE	5	YELLOW	---
---	SPARE	2	RED	---

18/19 #2 CONDUCTOR WIRE				
SNORKEL WIRE NO.	DESCRIPTION	B. REX WIRE NO.	BRAND REX WIRE COLOR	TERMINAL WIRING BOX
4	RUN - FROM PLATFORM	1	BLACK	ITEM 6
5	START - FROM PLATFORM	11	BROWN/BLACK	ITEM 6
28	SENSE LINE DUMP	12	BLACK/RED	ITEM 6
70	HI/LO SPEED SIGNAL	2	RED	ITEM 6
73	TILT SIGNAL POWER - RELAY	8	BLUE/BLACK	ITEM 6
125	THROTTLE (HIGH)	7	RED/BLACK	ITEM 6
160	HYD. VALVE SIGNAL	9	ORANGE/BLACK	ITEM 6
126	ENGINE KILL SIGNAL	4	ORANGE	ITEM 6
29	HORN	6	BROWN	ITEM 21
122	LOW SPEED LIFT/SWING	10	YELLOW/BLACK	ITEM 6
---	SPARE	5	YELLOW	---
---	SPARE	3	BLUE	---
190	COORDINATED STEER	13	BLUE/RED	ITEM 21
191	CRAB STEER	14	ORANGE/RED	ITEM 21
170	RANGE (2WD/4WD)	15	YELLOW/RED	ITEM 21
---	SPARE	16	BROWN/RED	---
---	SPARE	17	BLACK/BLUE	---
---	SPARE	18	RED/BLUE	---
---	SPARE	19	ORANGE/BLUE	---

12/8 CONDUCTOR WIRE				
SNORKEL WIRE NO.	DESCRIPTION	B. REX WIRE NO.	BRAND REX WIRE COLOR	TERMINAL WIRING BOX
1	POWER TO PLATFORM	2	RED	ITEM 5
2	POWER TO PLATFORM	7	RED/BLACK	ITEM 5
3	GROUND	1	BLACK	ITEM 5
6	EMER. POWER	4	ORANGE	ITEM 5
26	PLATFORM ROT. - CW	5	YELLOW	ITEM 5
27	PLATFORM ROT. - CCW	8	BLUE/BLACK	ITEM 5
110	110 VLOT - NEUTRAL	6	BROWN	---
110	110 VOLT - POWER	3	BLUE	---



F

E

D

C

B

A

# PLATFORM BOX

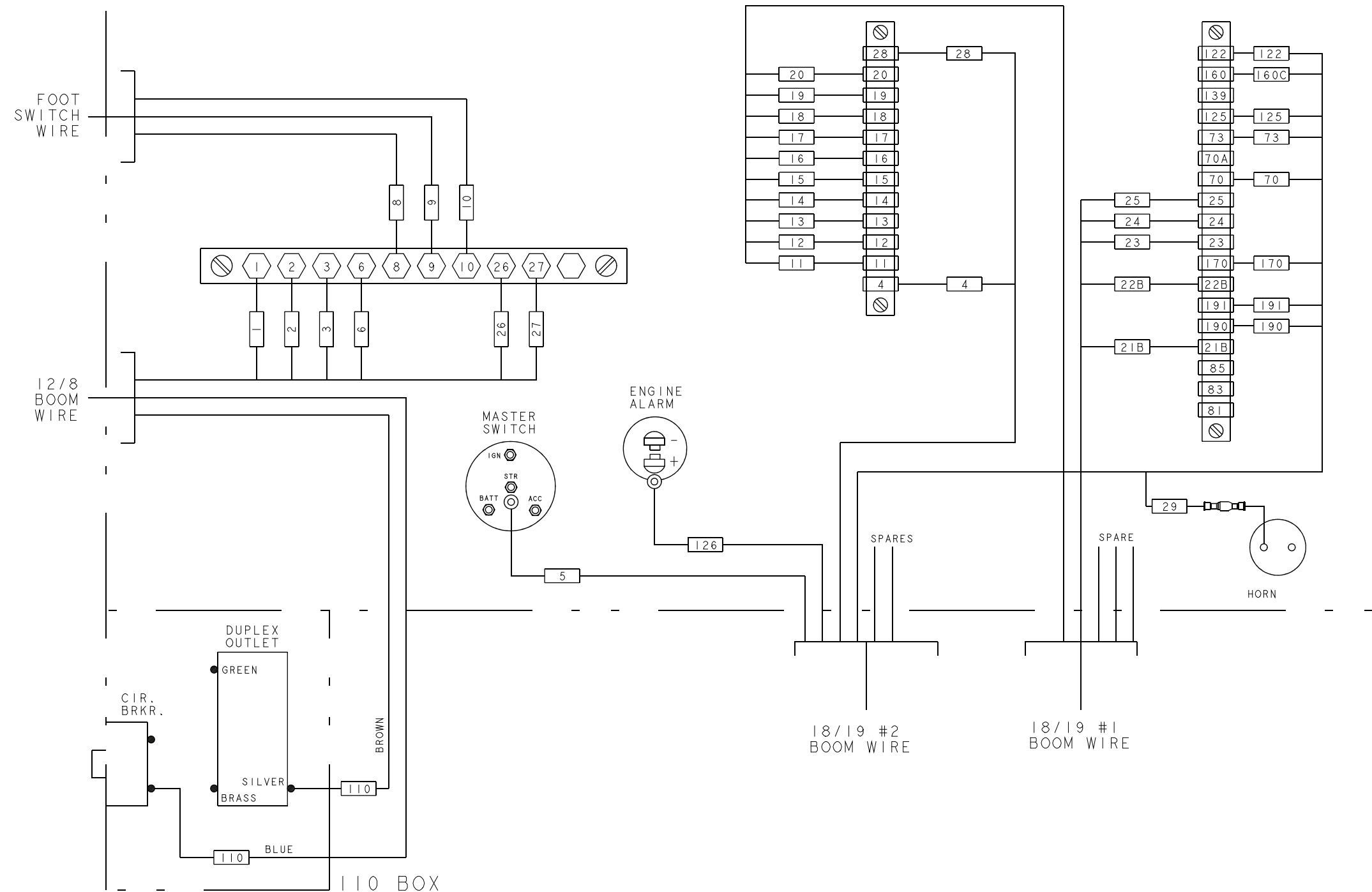

18/19 #1 CONDUCTOR WIRE				
SNORKEL WIRE NO.	DESCRIPTION	B. REX WIRE NO.	BRAND REX WIRE COLOR	TERMINAL PLATFORM BOX
11	RANGE (LOW MOTOR SPD)	12	BLACK/RED	ITEM 6
12	LEVEL - DOWN	13	BLUE/RED	ITEM 6
13	LEVEL - UP	14	ORANGE/RED	ITEM 6
14	BOOM - EXTEND	15	YELLOW/RED	ITEM 6
15	BOOM - RETRACT	6	BROWN	ITEM 6
16	HYD. SPEED	3	BLUE	ITEM 6
17	DRIVE - FORWARD	4	ORANGE	ITEM 6
18	DRIVE - REVERSE	10	YELLOW/BLACK	ITEM 6
19	STEER - LEFT	16	BROWN/RED	ITEM 6
20	STEER - RIGHT	8	BLUE/BLACK	ITEM 6
21B	MAIN BOOM - DOWN	19	ORANGE/BLUE	ITEM 6
---	SPARE	18	RED/BLUE	---
22B	MAIN BOOM - UP	7	RED/BLACK	ITEM 6
---	SPARE	9	ORANGE/BLACK	---
23	SWING - CCW	17	BLACK/BLUE	ITEM 6
24	SWING - CW	11	BROWN/BLACK	ITEM 6
25	THROTTLE - MED.	1	BLACK	ITEM 6
---	SPARE	5	YELLOW	---
---	SPARE	2	RED	---

18/19 #2 CONDUCTOR WIRE				
SNORKEL WIRE NO.	DESCRIPTION	B. REX WIRE NO.	BRAND REX WIRE COLOR	TERMINAL PLATFORM BOX
4	RUN - FROM PLATFORM	1	BLACK	ITEM 6
5	START - FROM PLATFORM	11	BROWN/BLACK	ITEM 21
28	SENSE LINE DUMP	12	BLACK/RED	ITEM 6
70	HI/LO SPEED SIGNAL	2	RED	ITEM 6
73	TILT SIGNAL POWER - RELAY	8	BLUE/BLACK	ITEM 6
125	THROTTLE (HIGH)	7	RED/BLACK	ITEM 6
160	HYD. VALVE SIGNAL	9	ORANGE/BLACK	ITEM 6
126	ENGINE KILL SIGNAL	4	ORANGE	ITEM 11
29	HORN	6	BROWN	ITEM 7
122	LOW SPEED LIFT/SWING	10	YELLOW/BLACK	ITEM 6
---	SPARE	5	YELLOW	---
---	SPARE	3	BLUE	---
190	COORDINATED STEER	13	BLUE/RED	ITEM 6
191	CRAB STEER	14	ORANGE/RED	ITEM 6
170	RANGE (2WD/4WD)	15	YELLOW/RED	ITEM 6
---	SPARE	16	BROWN/RED	---
---	SPARE	17	BLACK/BLUE	---
---	SPARE	18	RED/BLUE	---
---	SPARE	19	ORANGE/BLUE	---

12/8 CONDUCTOR WIRE				
SNORKEL WIRE NO.	DESCRIPTION	B. REX WIRE NO.	BRAND REX WIRE COLOR	TERMINAL PLATFORM BOX
1	POWER TO PLATFORM	2	RED	ITEM 5
2	POWER TO PLATFORM	7	RED/BLACK	ITEM 5
3	GROUND	1	BLACK	ITEM 5
6	EMER. POWER	4	ORANGE	ITEM 5
26	PLATFORM ROT. - CW	5	YELLOW	ITEM 5
27	PLATFORM ROT. - CCW	8	BLUE/BLACK	ITEM 5
110	110 VOLT (NEUTRAL)	6	BROWN	---
110	110 VOLT (POWER)	3	BLUE	---

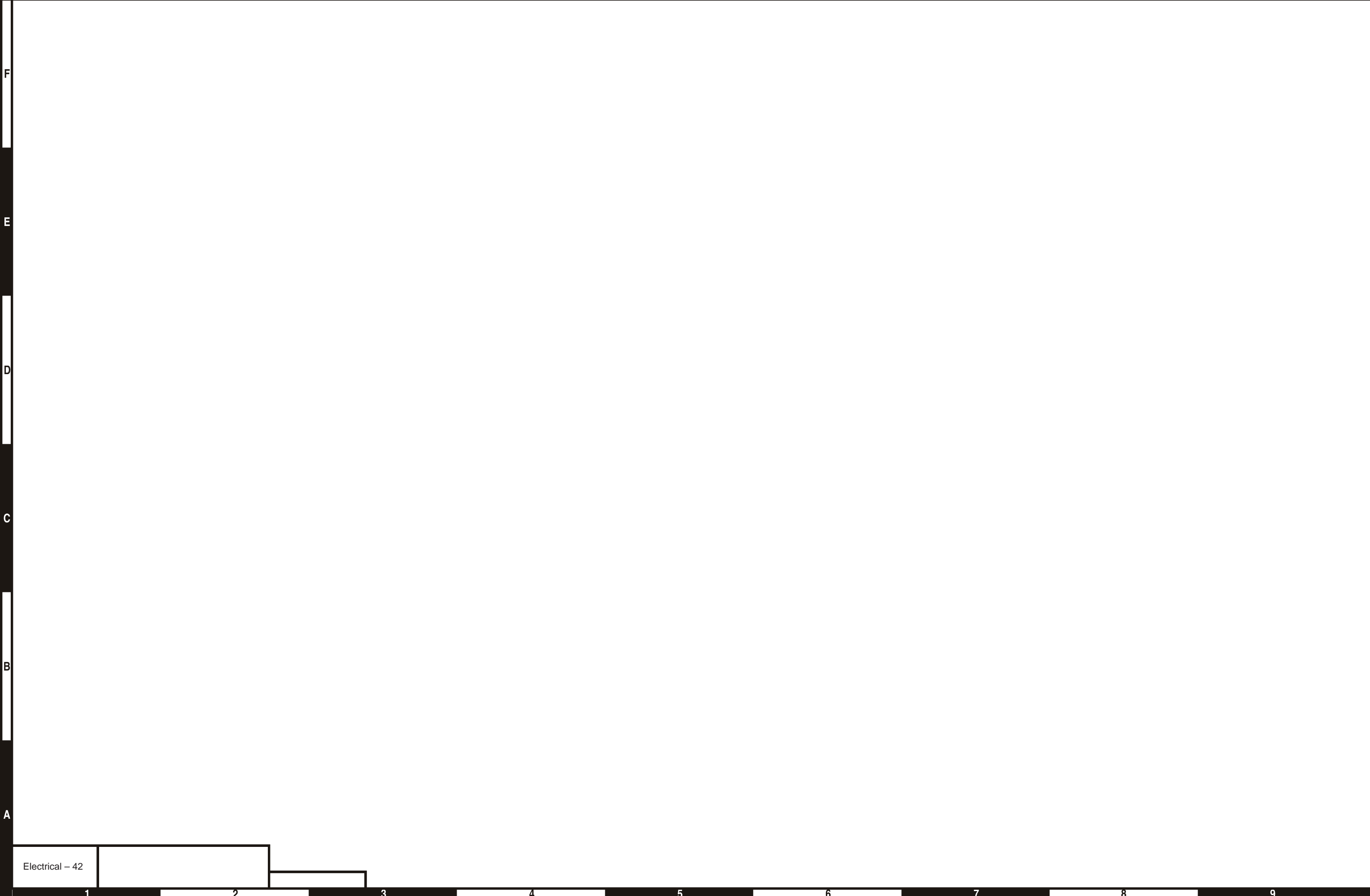

F

E

D

C

B

A

Electrical - 42

1

2

3

4

5

6

7

8

9

## Main Boom Electrical – TB80

Item	Part No.	Qty.	Description
1	0112744	1	WIRING BOX SUB ASSEMBLY
2	0112788	1	TURNTABLE WIRE ASSEMBLY
3	0071800	1	FOOTSWITCH ASSEMBLY
4	0112850	1	PLATFORM CONTROL BOX
5	3044854	13	TERM R101 12/10
6	3046972	48	TERM FEM1881 22/18
7	3040047	1	TERM FEM 250FI 22/18
8	0070747	1	WIRE 16 R61 R61 3
9	5093008	2	CLAMP (1.06)
10	5093010	1	CLAMP (1.50)
11	3044142	1	TERM R 61 22/18
13	970029	1	BOLT 1/4-20 X .75 LG
14	986019	2	WASHER 1/4 FLAT
15	987009	1	WASHER 1/4 MEDIUM LOCK
16	5560004	1	NUT 1/4-20 ESNA
17	970049	1	BOLT 1/4-20 X 1 LG
21	3044146	6	TERM R101 22/18

## Main Boom Electrical – TB80



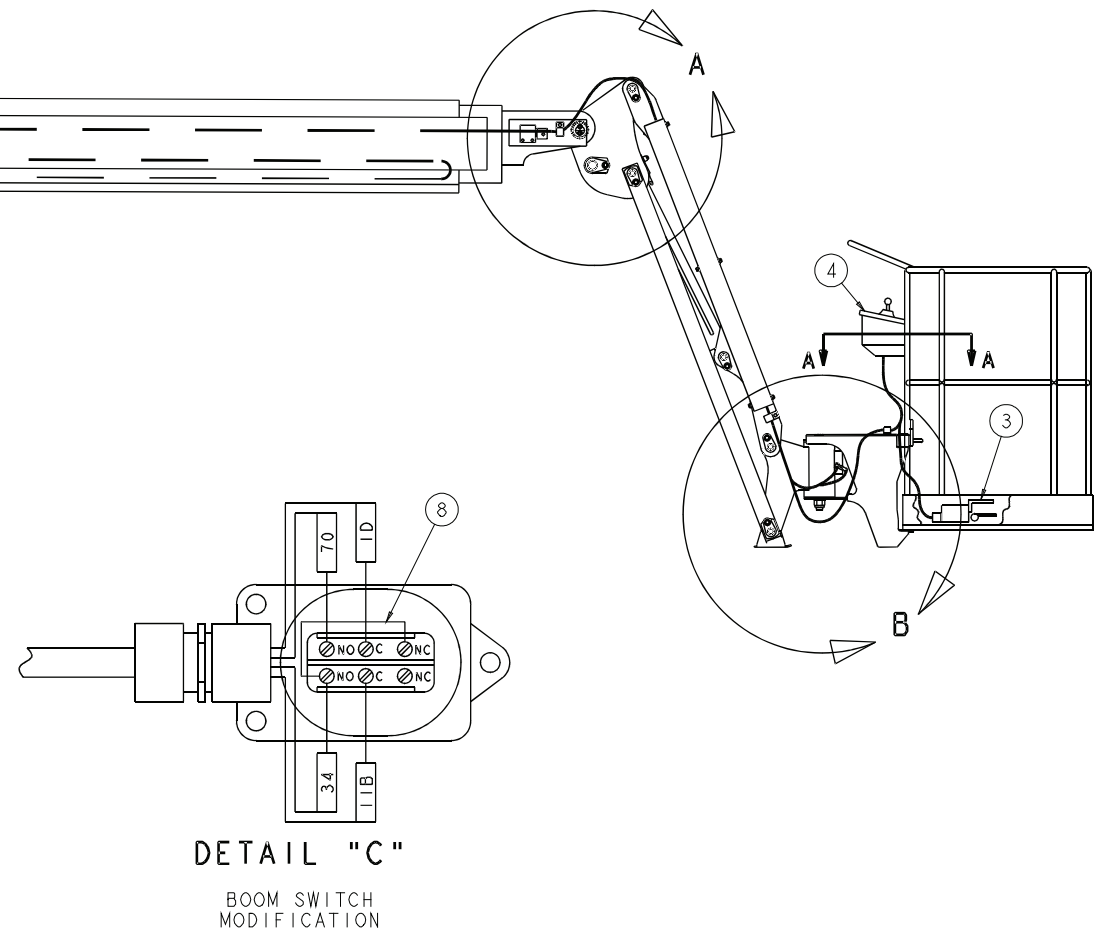
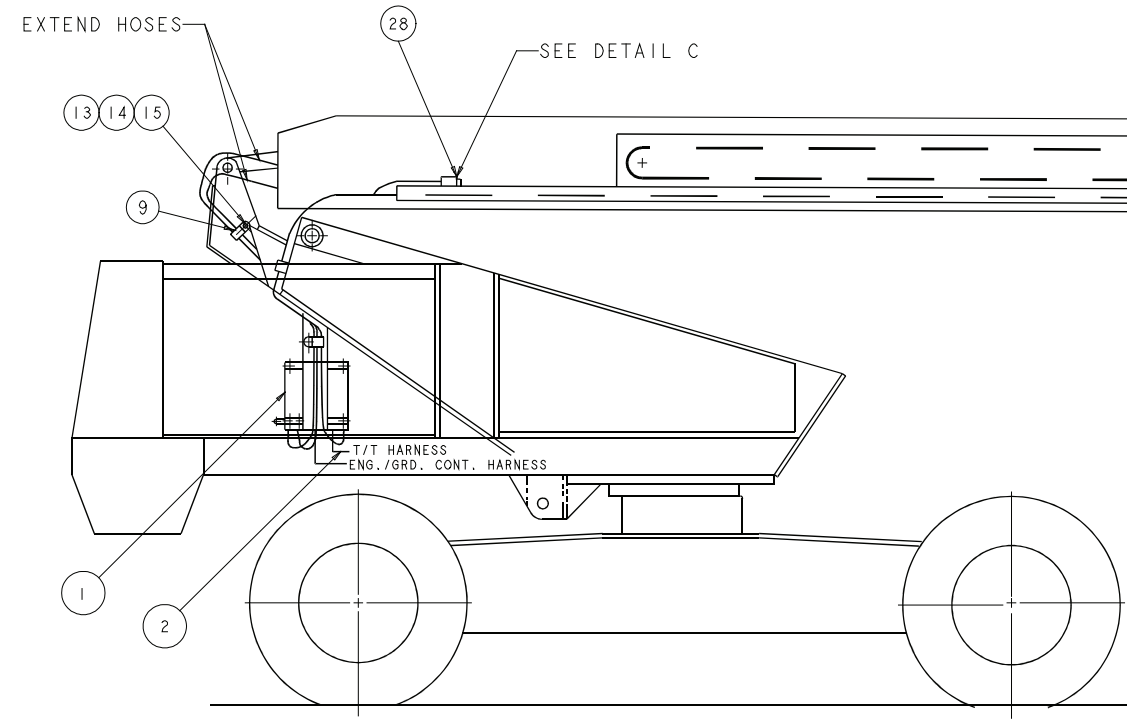
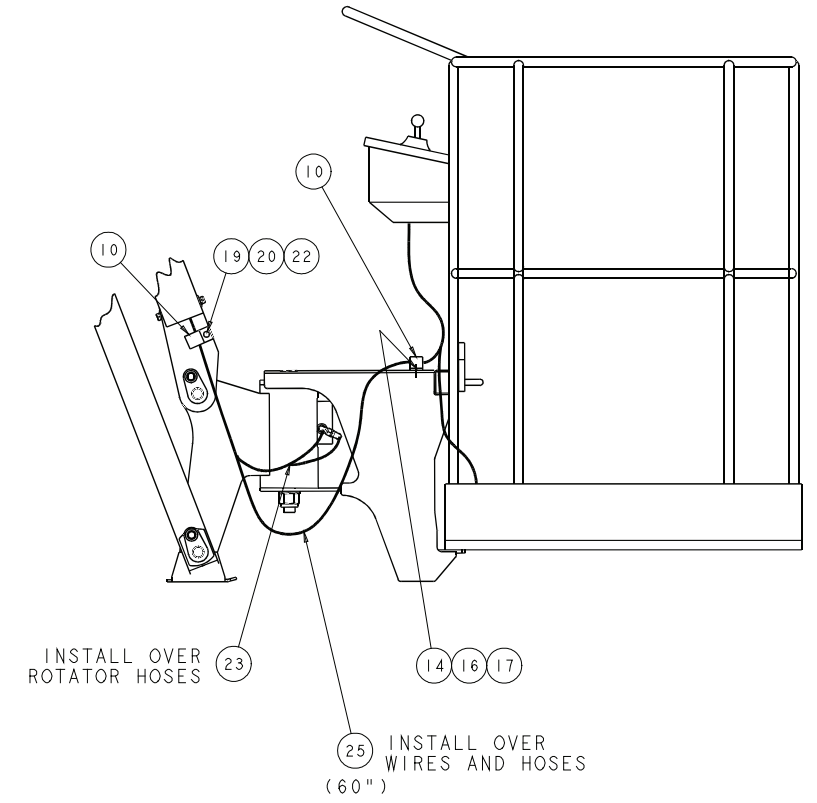
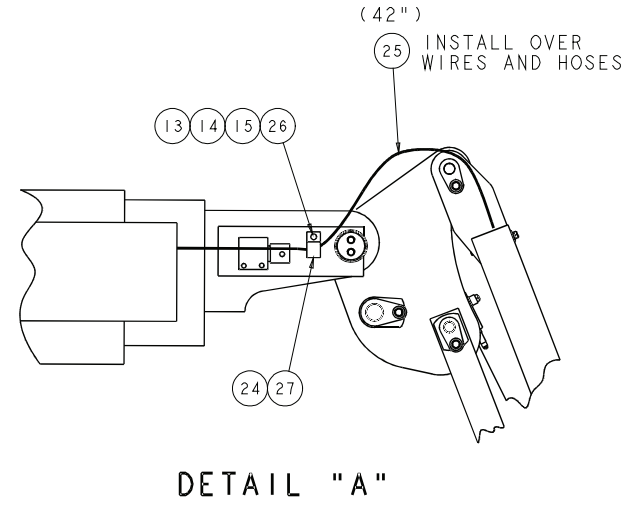
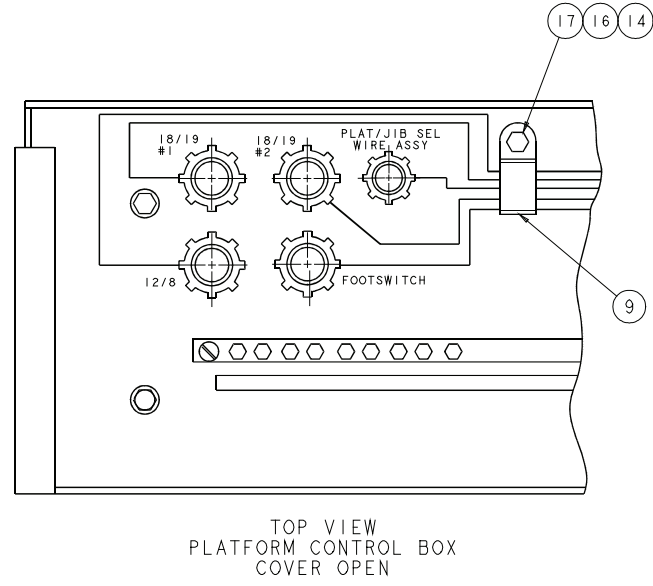
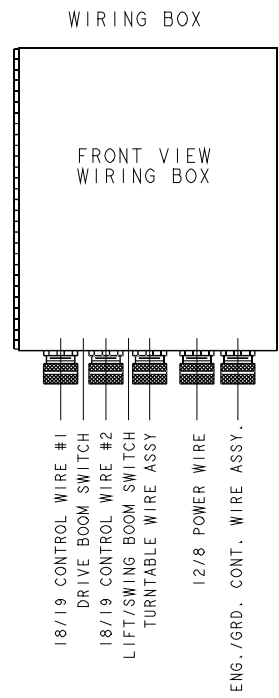

F  
E  
D  
C  
B  
A

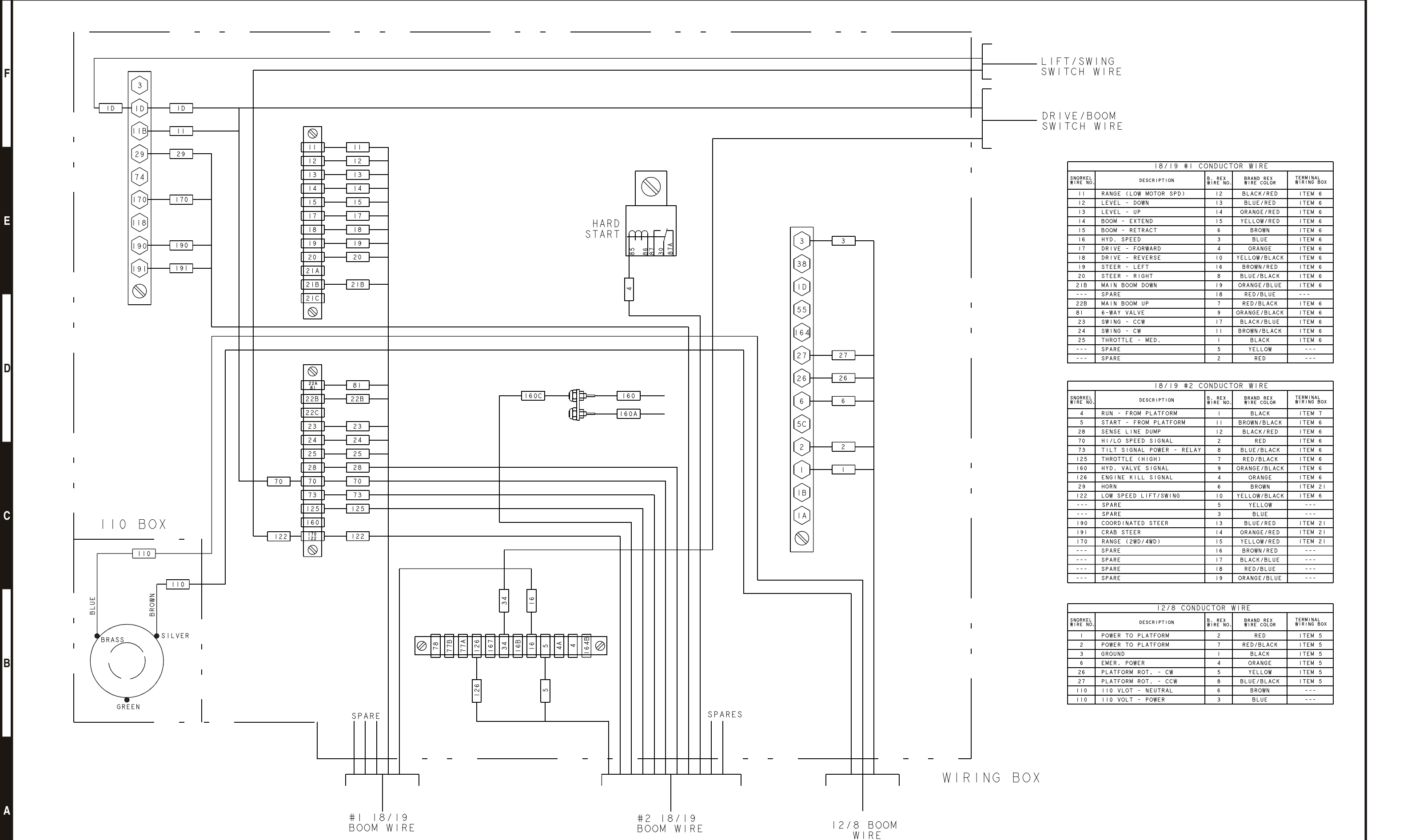

18/19 #1 CONDUCTOR WIRE				
SNORKEL WIRE NO.	DESCRIPTION	B. REX WIRE NO.	BRAND REX WIRE COLOR	TERMINAL WIRING BOX
11	RANGE (LOW MOTOR SPD)	12	BLACK/RED	ITEM 6
12	LEVEL - DOWN	13	BLUE/RED	ITEM 6
13	LEVEL - UP	14	ORANGE/RED	ITEM 6
14	BOOM - EXTEND	15	YELLOW/RED	ITEM 6
15	BOOM - RETRACT	6	BROWN	ITEM 6
16	HYD. SPEED	3	BLUE	ITEM 6
17	DRIVE - FORWARD	4	ORANGE	ITEM 6
18	DRIVE - REVERSE	10	YELLOW/BLACK	ITEM 6
19	STEER - LEFT	16	BROWN/RED	ITEM 6
20	STEER - RIGHT	8	BLUE/BLACK	ITEM 6
21B	MAIN BOOM DOWN	19	ORANGE/BLUE	ITEM 6
---	SPARE	18	RED/BLUE	---
22B	MAIN BOOM UP	7	RED/BLACK	ITEM 6
81	6-WAY VALVE	9	ORANGE/BLACK	ITEM 6
23	SWING - CCW	17	BLACK/BLUE	ITEM 6
24	SWING - CW	11	BROWN/BLACK	ITEM 6
25	THROTTLE - MED.	1	BLACK	ITEM 6
---	SPARE	5	YELLOW	---
---	SPARE	2	RED	---

18/19 #2 CONDUCTOR WIRE				
SNORKEL WIRE NO.	DESCRIPTION	B. REX WIRE NO.	BRAND REX WIRE COLOR	TERMINAL WIRING BOX
4	RUN - FROM PLATFORM	1	BLACK	ITEM 7
5	START - FROM PLATFORM	11	BROWN/BLACK	ITEM 6
28	SENSE LINE DUMP	12	BLACK/RED	ITEM 6
70	H1/LO SPEED SIGNAL	2	RED	ITEM 6
73	TILT SIGNAL POWER - RELAY	8	BLUE/BLACK	ITEM 6
125	THROTTLE (HIGH)	7	RED/BLACK	ITEM 6
160	HYD. VALVE SIGNAL	9	ORANGE/BLACK	ITEM 6
126	ENGINE KILL SIGNAL	4	ORANGE	ITEM 6
29	HORN	6	BROWN	ITEM 21
122	LOW SPEED LIFT/SWING	10	YELLOW/BLACK	ITEM 6
---	SPARE	5	YELLOW	---
---	SPARE	3	BLUE	---
190	COORDINATED STEER	13	BLUE/RED	ITEM 21
191	CRAB STEER	14	ORANGE/RED	ITEM 21
170	RANGE (2WD/4WD)	15	YELLOW/RED	ITEM 21
---	SPARE	16	BROWN/RED	---
---	SPARE	17	BLACK/BLUE	---
---	SPARE	18	RED/BLUE	---
---	SPARE	19	ORANGE/BLUE	---

12/8 CONDUCTOR WIRE				
SNORKEL WIRE NO.	DESCRIPTION	B. REX WIRE NO.	BRAND REX WIRE COLOR	TERMINAL WIRING BOX
1	POWER TO PLATFORM	2	RED	ITEM 5
2	POWER TO PLATFORM	7	RED/BLACK	ITEM 5
3	GROUND	1	BLACK	ITEM 5
6	EMER. POWER	4	ORANGE	ITEM 5
26	PLATFORM ROT. - CW	5	YELLOW	ITEM 5
27	PLATFORM ROT. - CCW	8	BLUE/BLACK	ITEM 5
110	110 VOLT - NEUTRAL	6	BROWN	---
110	110 VOLT - POWER	3	BLUE	---

F  
E  
D  
C  
B  
A

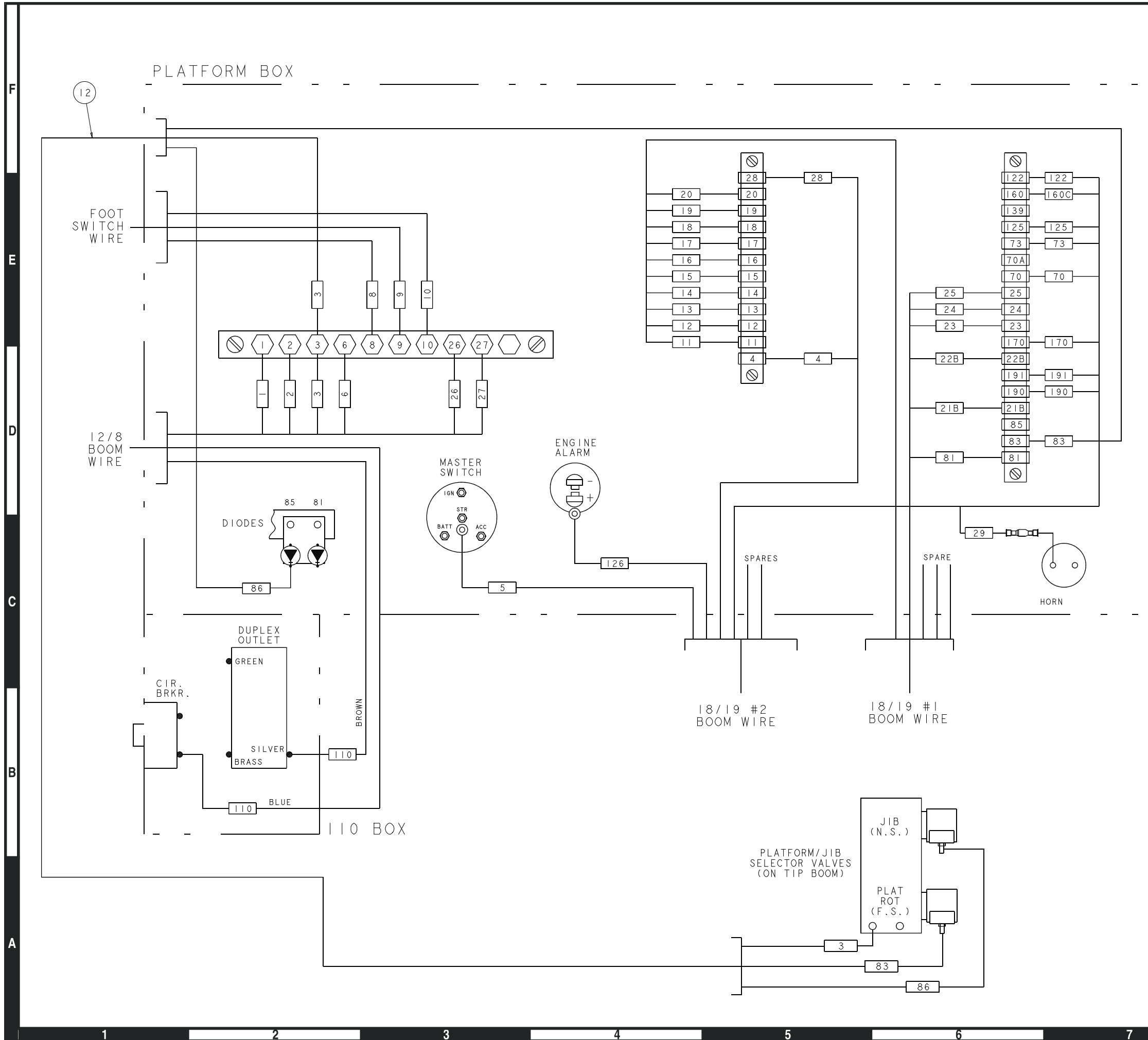

18/19 #1 CONDUCTOR WIRE				
SNORKEL WIRE NO.	DESCRIPTION	B. WIRE NO.	BRAND WIRE COLOR	TERMINAL PLATFORM BOX
11	RANGE (LOW MOTOR SPD)	12	BLACK/RED	ITEM 6
12	LEVEL - DOWN	13	BLUE/RED	ITEM 6
13	LEVEL - UP	14	ORANGE/RED	ITEM 6
14	BOOM - EXTEND	15	YELLOW/RED	ITEM 6
15	BOOM - RETRACT	6	BROWN	ITEM 6
16	HYD. SPEED	3	BLUE	ITEM 6
17	DRIVE - FORWARD	4	ORANGE	ITEM 6
18	DRIVE - REVERSE	10	YELLOW/BLACK	ITEM 6
19	STEER - LEFT	16	BROWN/RED	ITEM 6
20	STEER - RIGHT	8	BLUE/BLACK	ITEM 6
21B	MAIN BOOM - DOWN	19	ORANGE/BLUE	ITEM 6
---	SPARE	18	RED/BLUE	---
22B	MAIN BOOM - UP	7	RED/BLACK	ITEM 6
81	6-WAY VALVE	9	ORANGE/BLACK	ITEM 6
23	SWING - CCW	17	BLACK/BLUE	ITEM 6
24	SWING - CW	11	BROWN/BLACK	ITEM 6
25	THROTTLE - MED.	1	BLACK	ITEM 6
---	SPARE	5	YELLOW	---
---	SPARE	2	RED	---

18/19 #2 CONDUCTOR WIRE				
SNORKEL WIRE NO.	DESCRIPTION	B. WIRE NO.	BRAND WIRE COLOR	TERMINAL PLATFORM BOX
4	RUN - FROM PLATFORM	1	BLACK	ITEM 6
5	START - FROM PLATFORM	11	BROWN/BLACK	ITEM 21
28	SENSE LINE DUMP	12	BLACK/RED	ITEM 6
70	HI/LO SPEED SIGNAL	2	RED	ITEM 6
73	TILT SIGNAL POWER - RELAY	8	BLUE/BLACK	ITEM 6
125	THROTTLE (HIGH)	7	RED/BLACK	ITEM 6
160	HYD. VALVE SIGNAL	9	ORANGE/BLACK	ITEM 6
126	ENGINE KILL SIGNAL	4	ORANGE	ITEM 11
29	HORN	6	BROWN	ITEM 7
122	LOW SPEED LIFT/SWING	10	YELLOW/BLACK	ITEM 6
---	SPARE	5	YELLOW	---
---	SPARE	3	BLUE	---
190	COORDINATED STEER	13	BLUE/RED	ITEM 6
191	CRAB STEER	14	ORANGE/RED	ITEM 6
170	RANGE (2WD/4WD)	15	YELLOW/RED	ITEM 6
---	SPARE	16	BROWN/RED	---
---	SPARE	17	BLACK/BLUE	---
---	SPARE	18	RED/BLUE	---
---	SPARE	19	ORANGE/BLUE	---

12/8 CONDUCTOR WIRE				
SNORKEL WIRE NO.	DESCRIPTION	B. WIRE NO.	BRAND WIRE COLOR	TERMINAL PLATFORM BOX
1	POWER TO PLATFORM	2	RED	ITEM 5
2	POWER TO PLATFORM	7	RED/BLACK	ITEM 5
3	GROUND	1	BLACK	ITEM 5
6	EMER. POWER	4	ORANGE	ITEM 5
26	PLATFORM ROT. - CW	5	YELLOW	ITEM 5
27	PLATFORM ROT. - CCW	8	BLUE/BLACK	ITEM 5
110	110 VOLT (NEUTRAL)	6	BROWN	---
110	110 VOLT (POWER)	3	BLUE	---

Main Boom Electrical  
TB85J

0112738

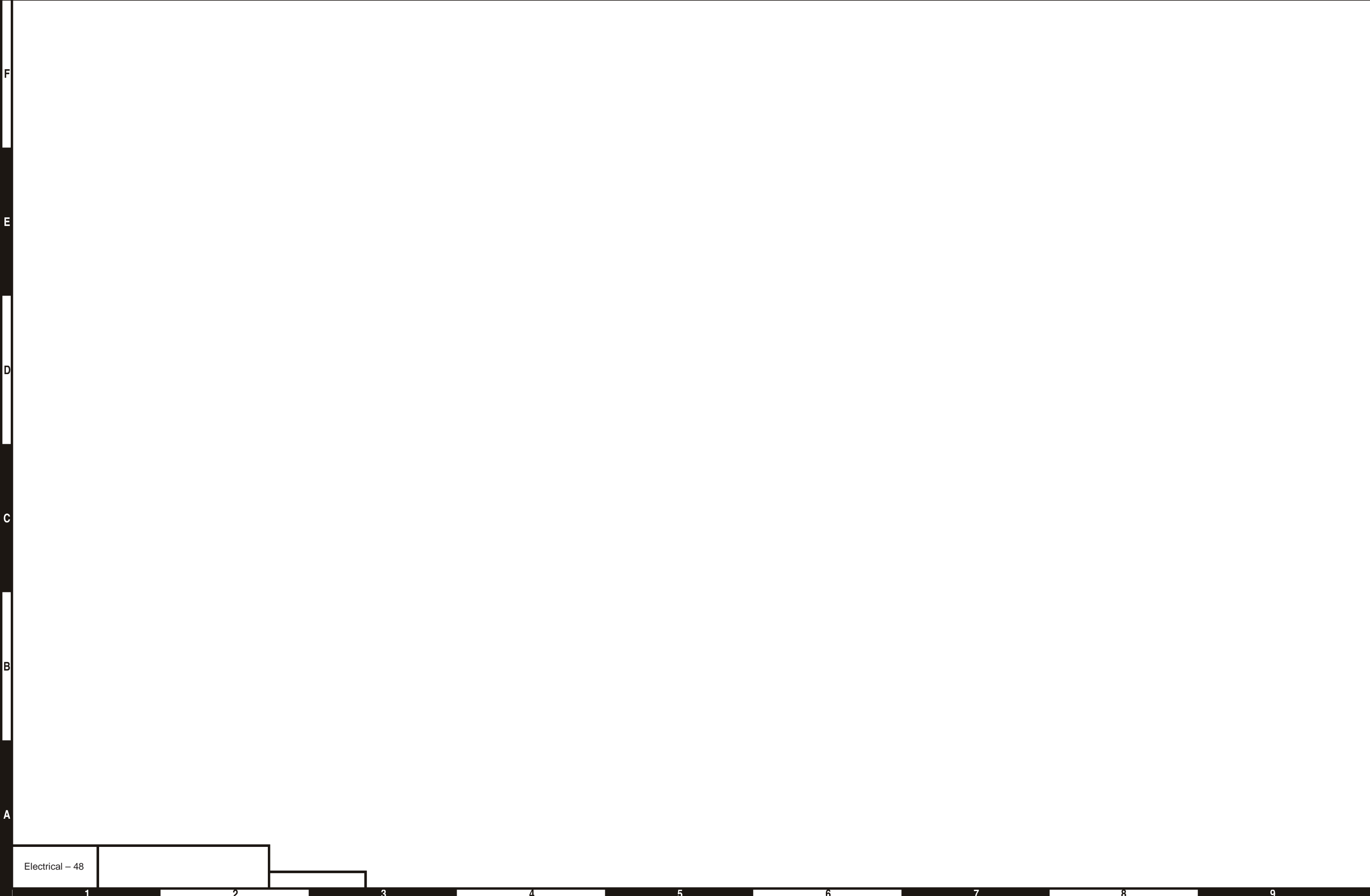

F

E

D

C

B

A

Electrical - 48

1

2

3

4

5

6

7

8

9



## Main Boom Electrical – TB85J

Item	Part No.	Qty.	Description
1	0112744	1	WIRING BOX SUB ASSEMBLY
2	0112788	1	TURNTABLE WIRE ASSEMBLY
3	0071800	1	FOOTSWITCH ASSEMBLY
4	0112739	1	PLATFORM CONTROL BOX
5	3044854	13	TERM R101 12/10
6	3046972	49	TERM FEM1881 22/18
7	3040047	2	TERM FEM 250FI 22/18
8	0070747	1	WIRE 16 R61 R61 3
9	5093008	2	CLAMP (1.06)
10	5093010	3	CLAMP (1.50)
11	3044142	1	TERM R 61 22/18
12	0112798	1	PLATFORM/JIB SELECTOR WIRE ASSEMBLY
13	970029	2	BOLT 1/4-20 X .75 LG
14	986019	4	WASHER 1/4 FLAT
15	987099	2	WASHER 1/4 MEDIUM LOCK
16	5560004	2	NUT 1/4-20 ESNA
17	970049	2	BOLT 1/4-20 X 1 LG
19	970439	1	BOLT .375-16 X .63 LG HH
20	987119	1	WASHER LOCK .375
21	3044146	6	TERM R101 22/18
22	986299	1	WASHER FLAT .375
23	563536	12 IN	SPIRIAL HOSE GUARD
24	5093024	1	CLAMP
25	5090034	8.5 FT	HOSE ABRASION SLEEVE
26	5560603	1	NUTSERT .250-20
27	0182452	1	SPACER .875 OD .375 ID .75 STL
28	0112997	1	ASSEMBLY BOOM SWITCH

## Main Boom Electrical – TB85J



F

E

D

C

B

A

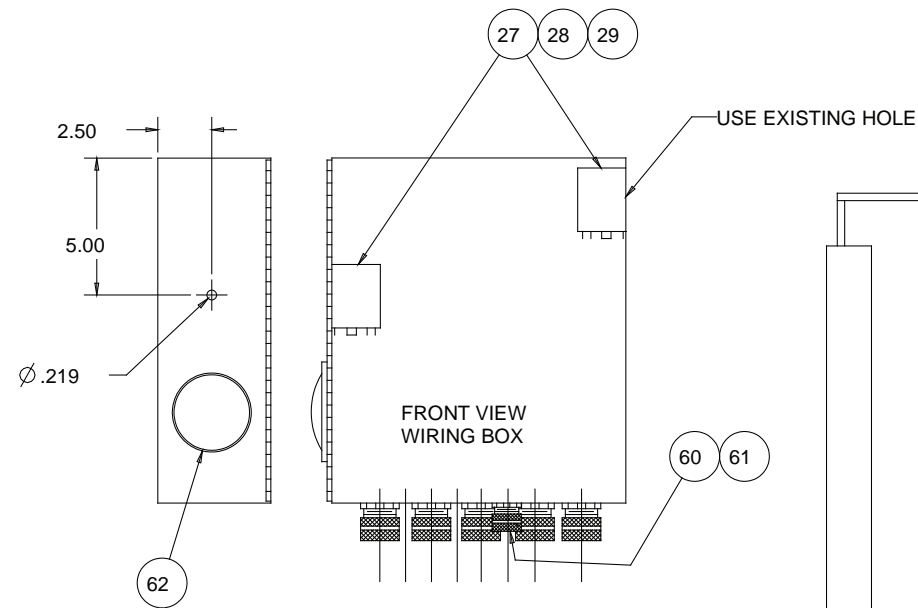

- 18/19 CONTROL WIRE #1
- DRIVE BOOM SWITCH
- 18/19 CONTROL WIRE #2
- LIFT/SWING BOOM SWITCH
- TURNABLE WIRE ASSY
- BOOM ANGLE SWITCH
- 12/8 POWER WIRE
- ENG./GRD. CONT. WIRE ASSY.

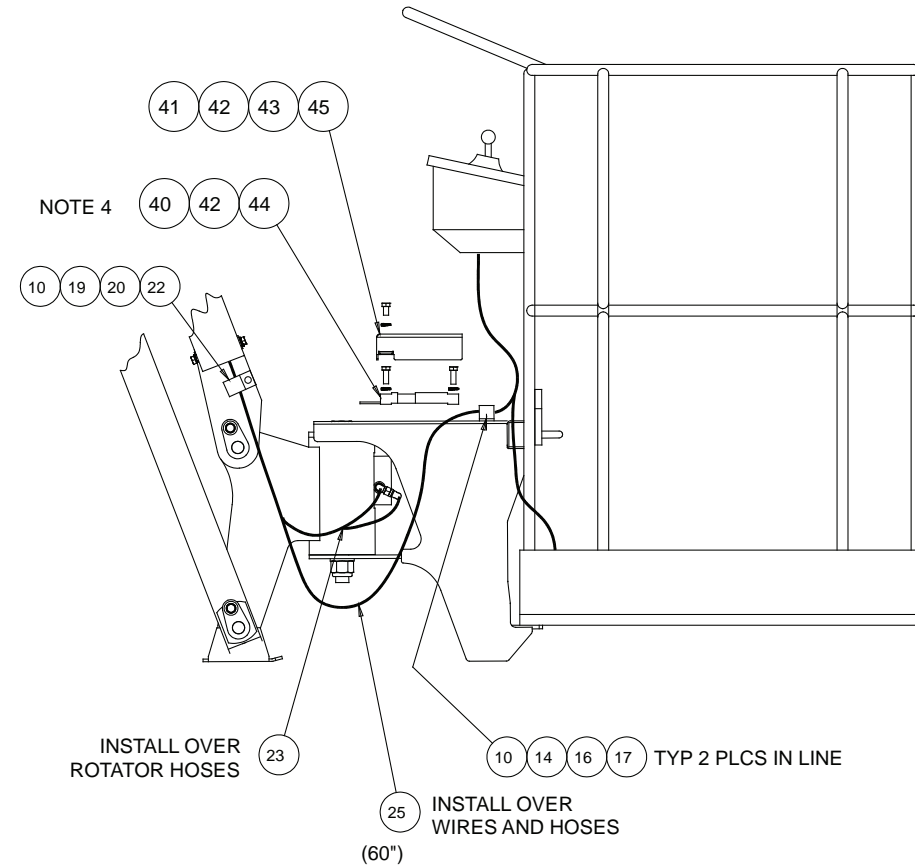
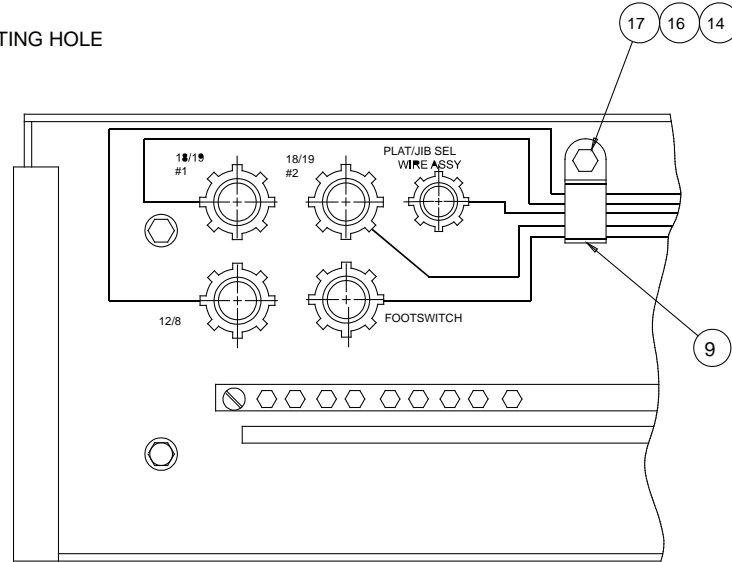

- NOTES:
1. SEE HOSE CARRIER DRAWING FOR INSTALLATION OF THESE WIRES IN HOSE CARRIER.
  2. SPRAY TERMINALS WITH KRYLON #1304 IGNITION AFTER ASSEMBLY.
  3. SEE DRAWING 0110892 FOR WIRE AND HOSE CLAMP INSTALLATIONS.
  4. SEE PLATFORM CONTROL BOX ASSY DRW 0112551 FOR SENSOR WIRING INSTRUCTIONS TORQUE SENSOR BOLTS TO 25 FT-LBS

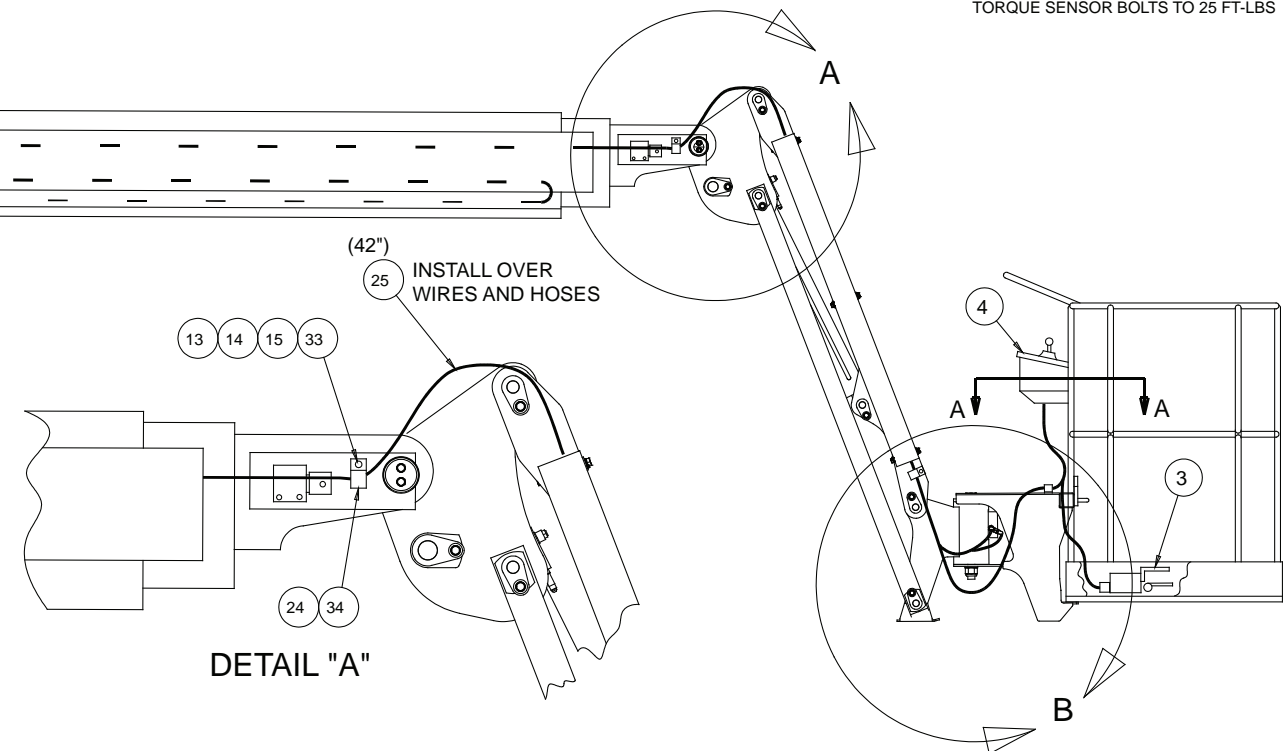
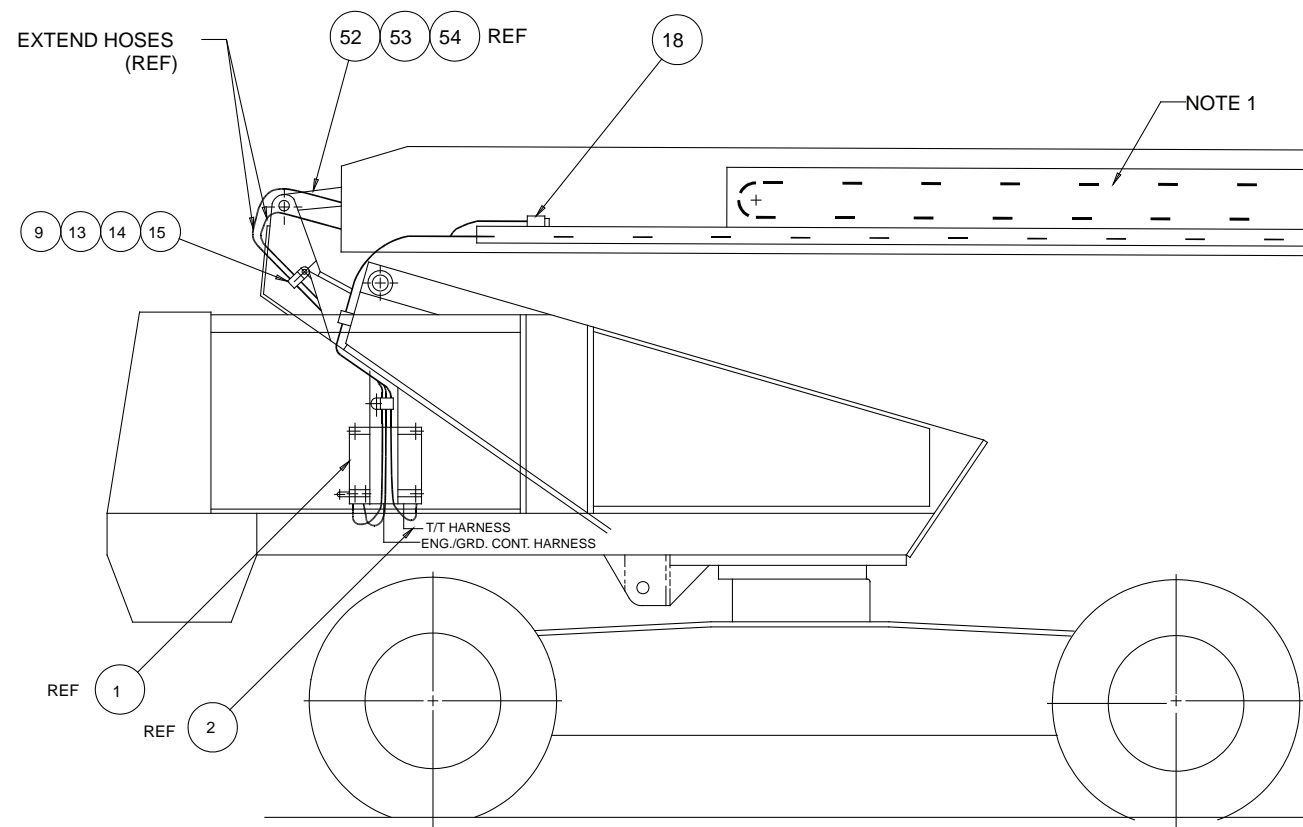

F

E

D

C

B

A

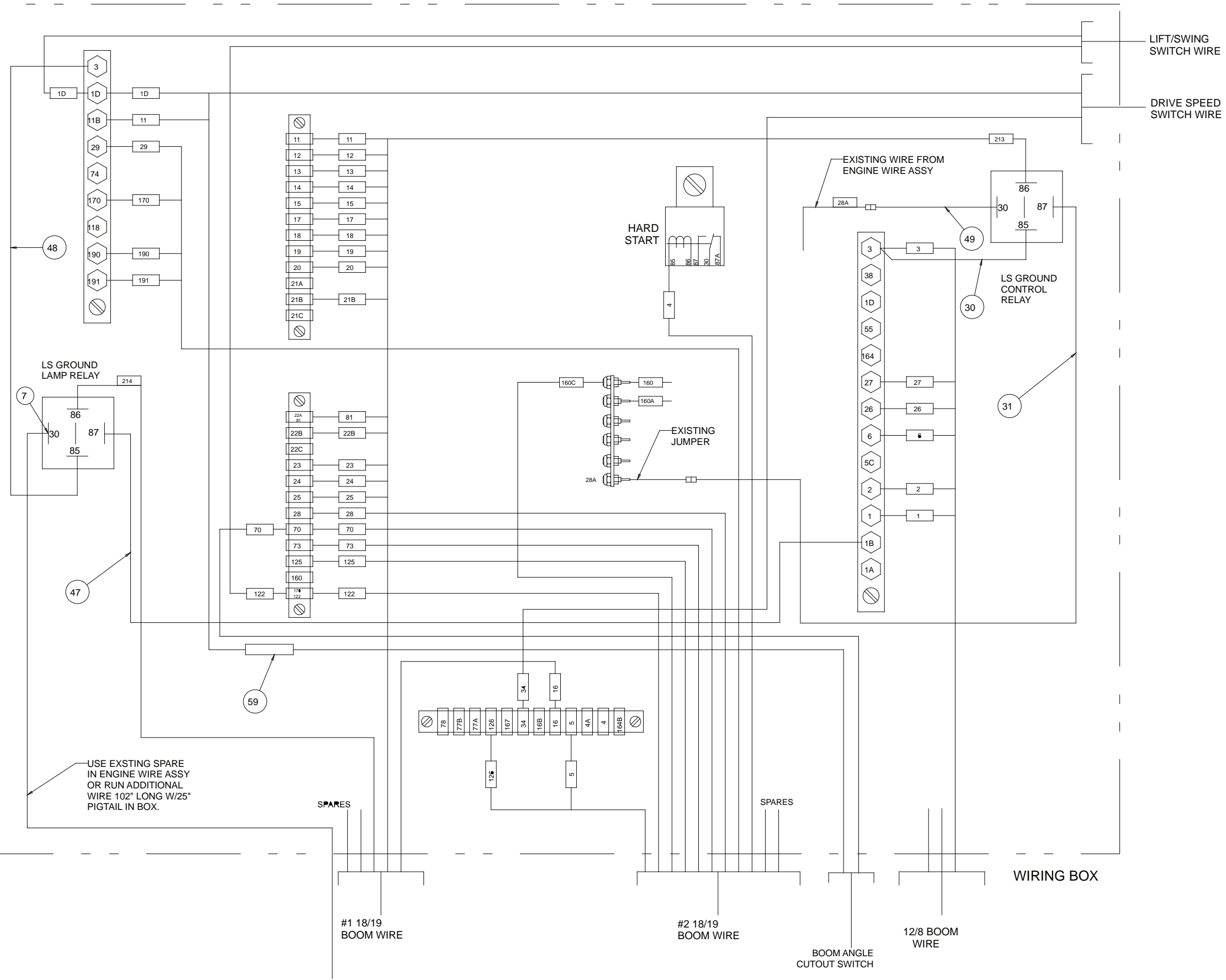

LIFT/SWING SWITCH WIRE

DRIVE SPEED SWITCH WIRE

18/19 #1 CONDUCTOR WIRE

SNORKEL WIRE NO.	DESCRIPTION	B. REX WIRE NO.	BRAND REX WIRE COLOR	TERMINAL WIRING BOX
11	RANGE (LOW MOTOR SPD)	12	BLACK/RED	ITEM 6
12	LEVEL - DOWN	13	BLUE/RED	ITEM 6
13	LEVEL - UP	14	ORANGE/RED	ITEM 6
14	BOOM - EXTEND	15	YELLOW/RED	ITEM 6
15	BOOM - RETRACT	6	BROWN	ITEM 6
16	HYD. SPEED	3	BLUE	ITEM 6
17	DRIVE - FORWARD	4	ORANGE	ITEM 6
18	DRIVE - REVERSE	10	YELLOW/BLACK	ITEM 6
19	STEER - LEFT	16	BROWN/RED	ITEM 6
20	STEER - RIGHT	8	BLUE/BLACK	ITEM 6
21B	MAIN BOOM DOWN	19	ORANGE/BLUE	ITEM 6
---	SPARE	18	RED/BLUE	---
22B	MAIN BOOM UP	7	RED/BLACK	ITEM 6
81	6-WAY VALVE	9	ORANGE/BLACK	ITEM 6
23	SWING - CCW	17	BLACK/BLUE	ITEM 6
24	SWING - CW	11	BROWN/BLACK	ITEM 6
25	THROTTLE - MED.	1	BLACK	ITEM 6
213	LOAD SENSE BOX (X)	5	YELLOW	ITEM 7
214	LOAD SENSE BOX (4)	2	RED	ITEM 7

18/19 #2 CONDUCTOR WIRE

SNORKEL WIRE NO.	DESCRIPTION	B. REX WIRE NO.	BRAND REX WIRE COLOR	TERMINAL WIRING BOX
4	RUN - FROM PLATFORM	1	BLACK	ITEM 7
5	START - FROM PLATFORM	11	BROWN/BLACK	ITEM 6
28	SENSE LINE DUMP	12	BLACK/RED	ITEM 6
70	HI/LO SPEED SIGNAL	2	RED	ITEM 6
73	TILT SIGNAL POWER - RELAY	8	BLUE/BLACK	ITEM 6
125	THROTTLE (HIGH)	7	RED/BLACK	ITEM 6
160	HYD. VALVE SIGNAL	9	ORANGE/BLACK	ITEM 6
126	ENGINE KILL SIGNAL	4	ORANGE	ITEM 6
29	HORN	6	BROWN	ITEM 21
122	LOW SPEED LIFT/SWING	10	YELLOW/BLACK	ITEM 6
1D	LOAD SENSE	5	YELLOW	ITEM 7
---	SPARE	3	BLUE	---
190	COORDINATED STEER	13	BLUE/RED	ITEM 21
191	CRAB STEER	14	ORANGE/RED	ITEM 21
170	RANGE (2WD/4WD)	15	YELLOW/RED	ITEM 21
---	SPARE	16	BROWN/RED	---
---	SPARE	17	BLACK/BLUE	---
---	SPARE	18	RED/BLUE	---
---	SPARE	19	ORANGE/BLUE	---

12/8 CONDUCTOR WIRE

SNORKEL WIRE NO.	DESCRIPTION	B. REX WIRE NO.	BRAND REX WIRE COLOR	TERMINAL WIRING BOX
1	POWER TO PLATFORM	2	RED	ITEM 5
2	POWER TO PLATFORM	7	RED/BLACK	ITEM 5
3	GROUND	1	BLACK	ITEM 5
6	EMER. POWER	4	ORANGE	ITEM 5
26	PLATFORM ROT. - CW	5	YELLOW	ITEM 5
27	PLATFORM ROT. - CCW	8	BLUE/BLACK	ITEM 5
110	110 VLOT - NEUTRAL	6	BROWN	---
110	110 VOLT - POWER	3	BLUE	---

F

E

D

C

B

A

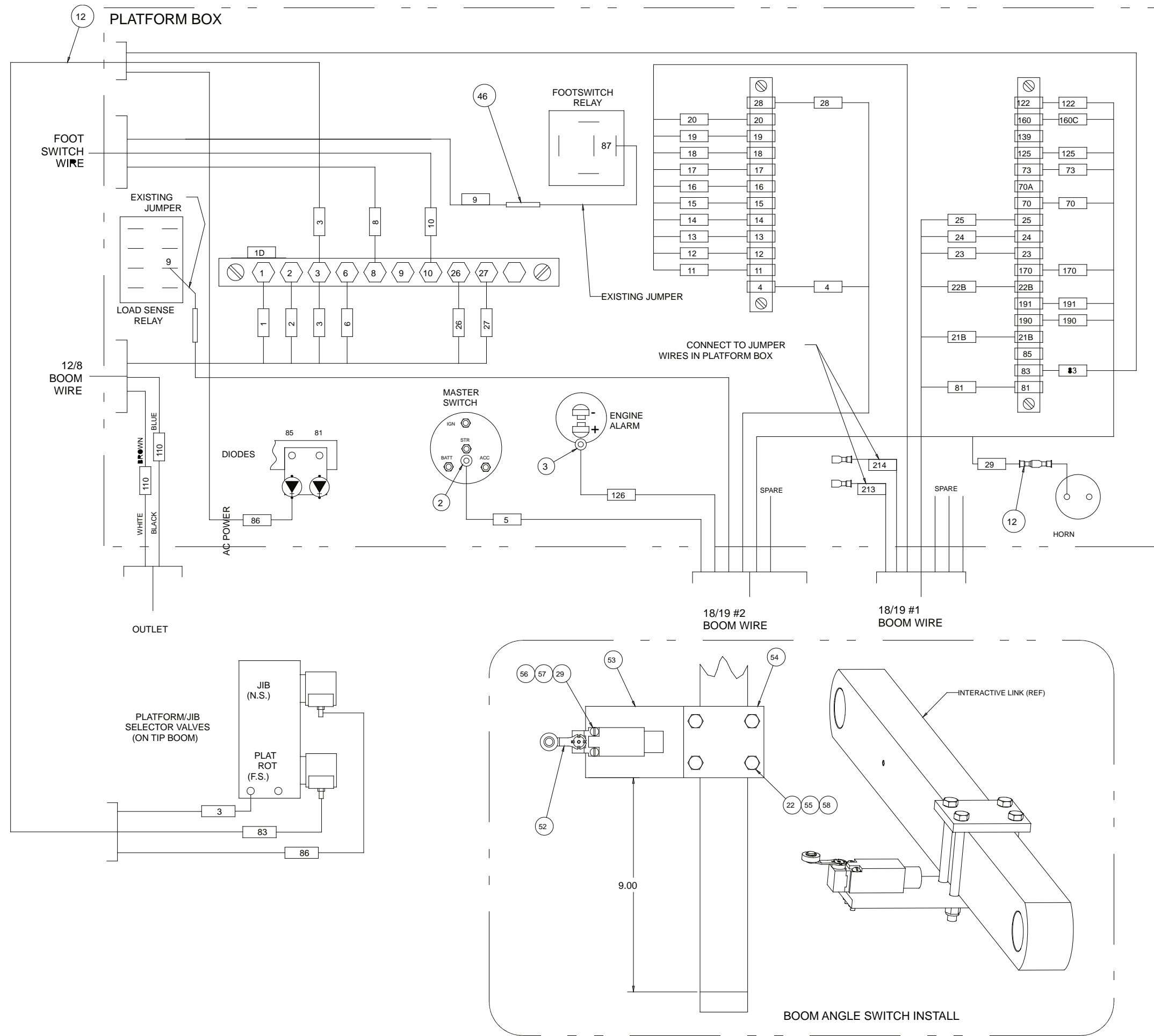

18/19 #1 CONDUCTOR WIRE				
SNORKEL WIRE NO.	DESCRIPTION	B. REX WIRE NO.	BRAND REX WIRE COLOR	TERMINAL PLATFORM BOX
11	RANGE (LOW MOTOR SPD)	12	BLACK/RED	ITEM 6
12	LEVEL - DOWN	13	BLUE/RED	ITEM 6
13	LEVEL - UP	14	ORANGE/RED	ITEM 6
14	BOOM - EXTEND	15	YELLOW/RED	ITEM 6
15	BOOM - RETRACT	6	BROWN	ITEM 6
16	HYD. SPEED	3	BLUE	ITEM 6
17	DRIVE - FORWARD	4	ORANGE	ITEM 6
18	DRIVE - REVERSE	10	YELLOW/BLACK	ITEM 6
19	STEER - LEFT	16	BROWN/RED	ITEM 6
20	STEER - RIGHT	8	BLUE/BLACK	ITEM 6
21B	MAIN BOOM - DOWN	19	ORANGE/BLUE	ITEM 6
---	SPARE	18	RED/BLUE	---
22B	MAIN BOOM - UP	7	RED/BLACK	ITEM 6
81	6-WAY VALVE	9	ORANGE/BLACK	ITEM 6
23	SWING - CCW	17	BLACK/BLUE	ITEM 6
24	SWING - CW	11	BROWN/BLACK	ITEM 6
25	THROTTLE - MED.	1	BLACK	ITEM 6
213	LOAD SENSE BOX (X)	5	YELLOW	ITEM 7
214	LOAD SENSE BOX (4)	2	RED	ITEM 7

18/19 #2 CONDUCTOR WIRE				
SNORKEL WIRE NO.	DESCRIPTION	B. REX WIRE NO.	BRAND REX WIRE COLOR	TERMINAL PLATFORM BOX
4	RUN - FROM PLATFORM	1	BLACK	ITEM 6
5	START - FROM PLATFORM	11	BROWN/BLACK	ITEM 21
28	SENSE LINE DUMP	12	BLACK/RED	ITEM 6
70	HI/LO SPEED SIGNAL	2	RED	ITEM 6
73	TILT SIGNAL POWER - RELAY	8	BLUE/BLACK	ITEM 6
125	THROTTLE (HIGH)	7	RED/BLACK	ITEM 6
160	HYD. VALVE SIGNAL	9	ORANGE/BLACK	ITEM 6
126	ENGINE KILL SIGNAL	4	ORANGE	ITEM 11
29	HORN	6	BROWN	ITEM 7
122	LOW SPEED LIFT/SWING	10	YELLOW/BLACK	ITEM 6
1D	LOAD SENSE	5	YELLOW	ITEM 7
---	SPARE	3	BLUE	---
190	COORDINATED STEER	13	BLUE/RED	ITEM 6
191	CRAB STEER	14	ORANGE/RED	ITEM 6
170	RANGE (2WD/4WD)	15	YELLOW/RED	ITEM 6
---	SPARE	16	BROWN/RED	---
---	SPARE	17	BLACK/BLUE	---
---	SPARE	18	RED/BLUE	---
---	SPARE	19	ORANGE/BLUE	---

12/8 CONDUCTOR WIRE				
SNORKEL WIRE NO.	DESCRIPTION	B. REX WIRE NO.	BRAND REX WIRE COLOR	TERMINAL PLATFORM BOX
1	POWER TO PLATFORM	2	RED	ITEM 5
2	POWER TO PLATFORM	7	RED/BLACK	ITEM 5
3	GROUND	1	BLACK	ITEM 5
6	EMER. POWER	4	ORANGE	ITEM 5
26	PLATFORM ROT. - CW	5	YELLOW	ITEM 5
27	PLATFORM ROT. - CCW	8	BLUE/BLACK	ITEM 5
110	110 VOLT (NEUTRAL)	6	BROWN	---
110	110 VOLT (POWER)	3	BLUE	---

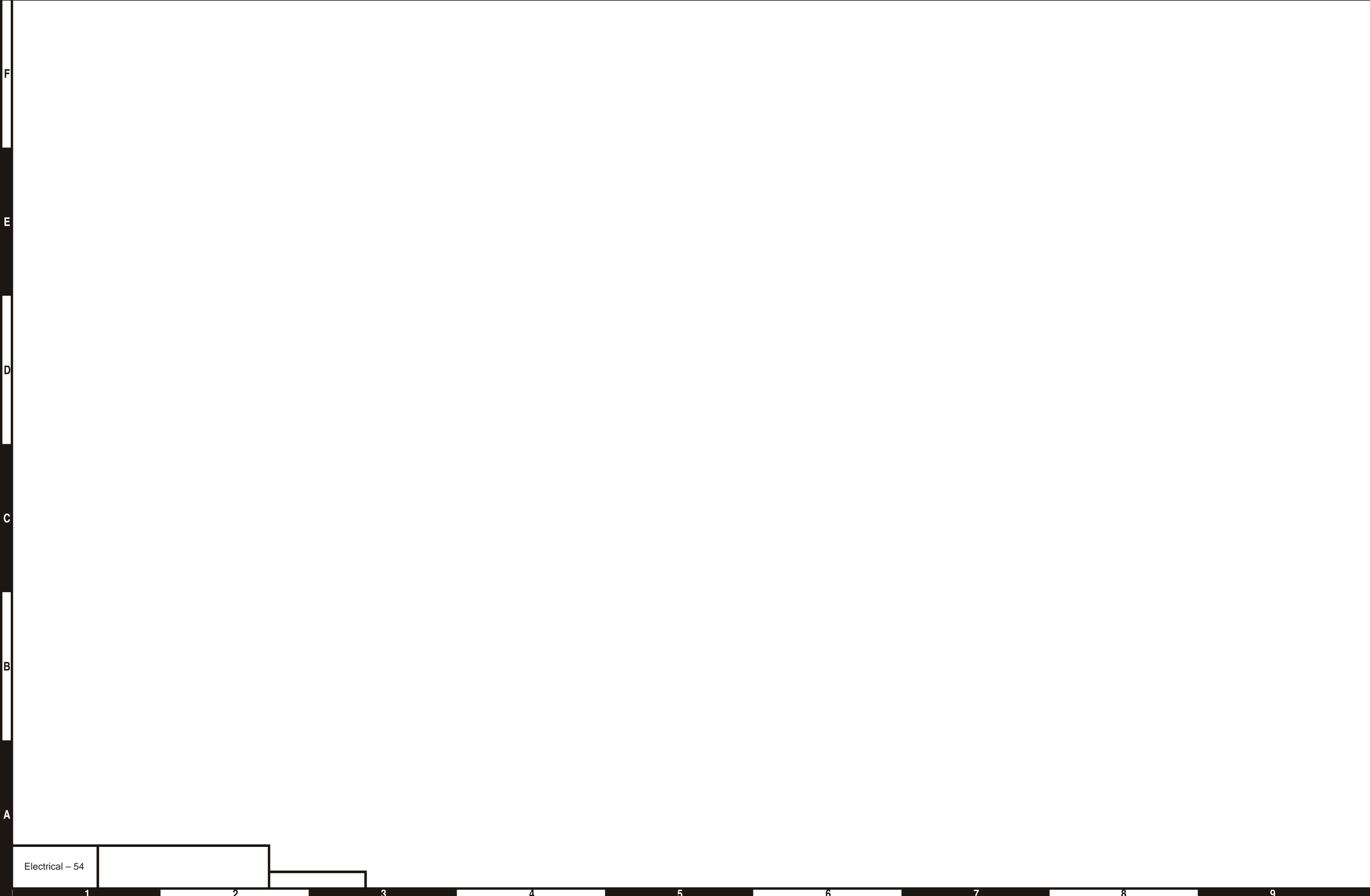

F

E

D

C

B

A

Electrical - 54

1

2

3

4

5

6

7

8

9

## Main Boom Electrical – CE

Item	Part No.	Qty.	Description
1	0112744	1	WIRING BOX SUB ASSEMBLY
2	0112788	1	TURNTABLE WIRE ASSEMBLY
3	0071800	1	FOOTSWITCH ASSEMBLY
4	0112825	1	PLATFORM CONTROL BOX
5	3044854	13	TERM R101 12/10
6	3046972	49	TERM FEM1881 22/18
7	3040047	2	TERM FEM 250FI 22/18
9	5093008	2	CLAMP (1.06)
10	5093010	3	CLAMP (1.50)
11	3044142	1	TERM R 61 22/18
12	0112798	1	PLATFORM/JIB SELECTOR WIRE ASSEMBLY
13	970029	2	BOLT 1/4-20 X .75 LG
14	986019	4	WASHER 1/4 FLAT
15	987099	2	WASHER 1/4 MEDIUM LOCK
16	5560004	2	NUT 1/4-20 ESNA
17	970049	2	BOLT 1/4-20 X 1 LG
18	0112997	1	BOOM SWITCH ASSEMBLY
19	970439	1	BOLT .375-16 X .63 LG HH
20	987119	1	WASHER LOCK .375
21	3044146	6	TERM R101 22/18
22	986299	1	WASHER FLAT .375
23	563536	12 IN	SPRIAL HOSE GUARD
24	5093024	1	CLAMP
25	5090034	8.5 FT	HOSE ABRASION SLEEVE
27	3040469	3	RELAY SPDT 12V 30AMP
28	974659	2	SCREW, #10-24 X .500
29	5560034	4	NUT #10-24 LOCK
30	0071556	1	WIRE 16 R10I FEM250FI 24
31	0130095	1	WIRE 16 FEM250FI FEM250FI 24
33	5560603	1	NUTSERT .250-20
34	0172452	1	SPACER .872 OD .375 ID .75 STL
35	0181111	1	WIRE 16 R10I FEM250FI 5
36	0182065	1	WIRE 16 MALE250FI FEM250FI 6
40	3030166	1	LOAD LIMITER, SENSOR
41	0182057	1	COVER, SENSOR
42	9878119	4	WASHER, LOCK .375
43	970469	2	BOLT, HEXHD .375-16 1.00 GR5
44	970436	2	BOLT, HEXHD .375-16 .625
45	5569003	1	GROMMET .188 ID .438OD .125-AN9
46	3044071	2	TERM BUTT CONN INSUL 16/14
47	0071812	1	WIRE 16 R10 FEM250FI 18
48	0071556	1	WIRE 16 R10I FEM250FI 24
49	0182065	1	WIRE 16 MALE250FI FEM250FI 6
52	0112646	1	BOOM ANGLE SWITCH ASSEMBLY
53	0112632	1	BRACKET, FRONT SWITCH
54	0112633	1	BRACKET, BACK SWITCH
55	970589	4	BOLT, .375-16 X 4.50 LG
56	974739	2	SCREW, RHD #10-24 X 1.75 LG
57	986009	2	WASHER, FLAT #10
58	5560033	4	NUT, 3/8-16 LOCK
59	3044070	1	TERM BUTT 22/18
60	3040300	1	CONNECTOR, .500 .188-.313
61	3040070	1	NUT, LKG .500 HUB
62	3040286	1	PLUG, 2.00 HOLE

## Main Boom Electrical – CE





# Lower Controls – TB80

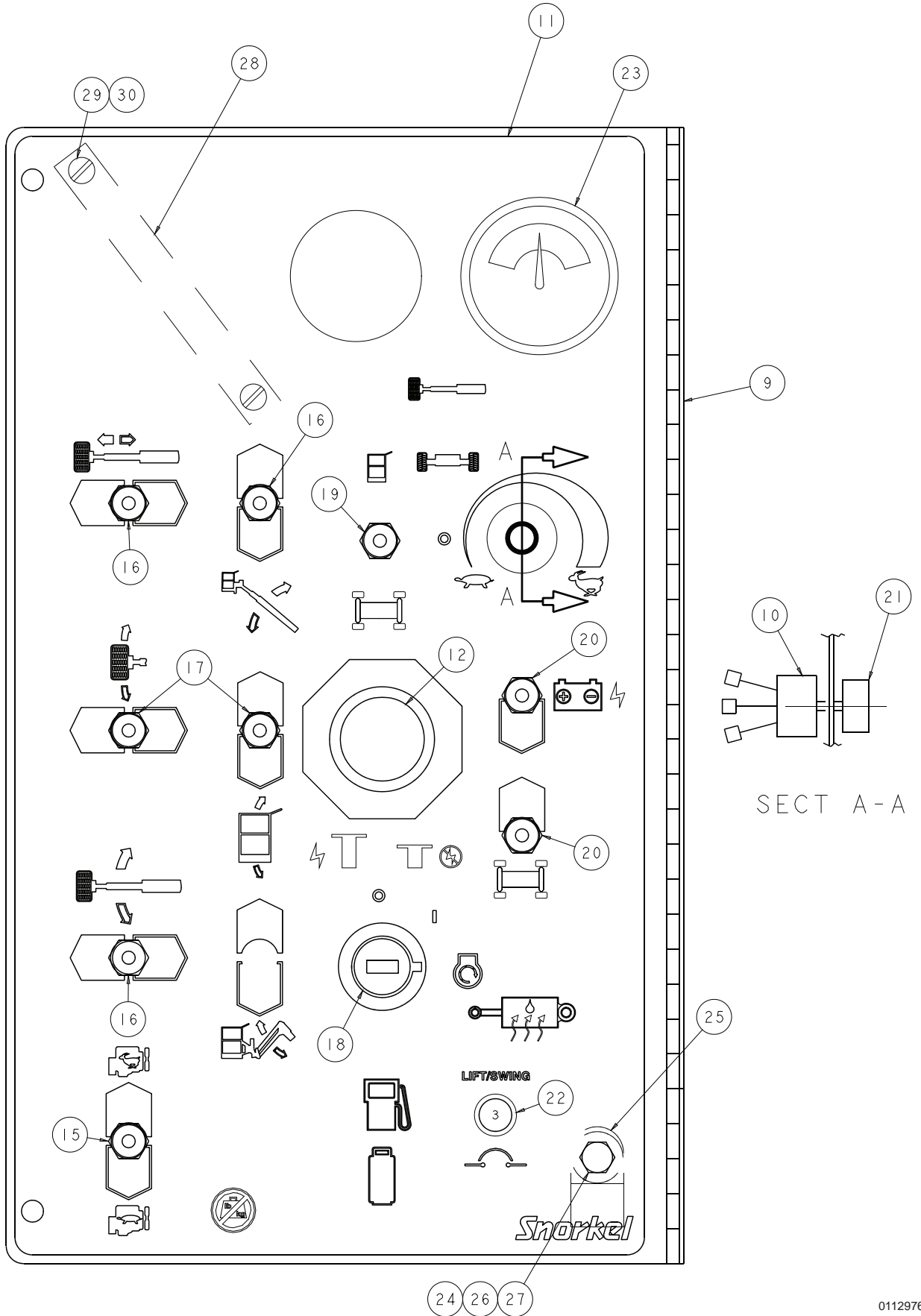

# Lower Controls – TB80

# Lower Controls – TB80

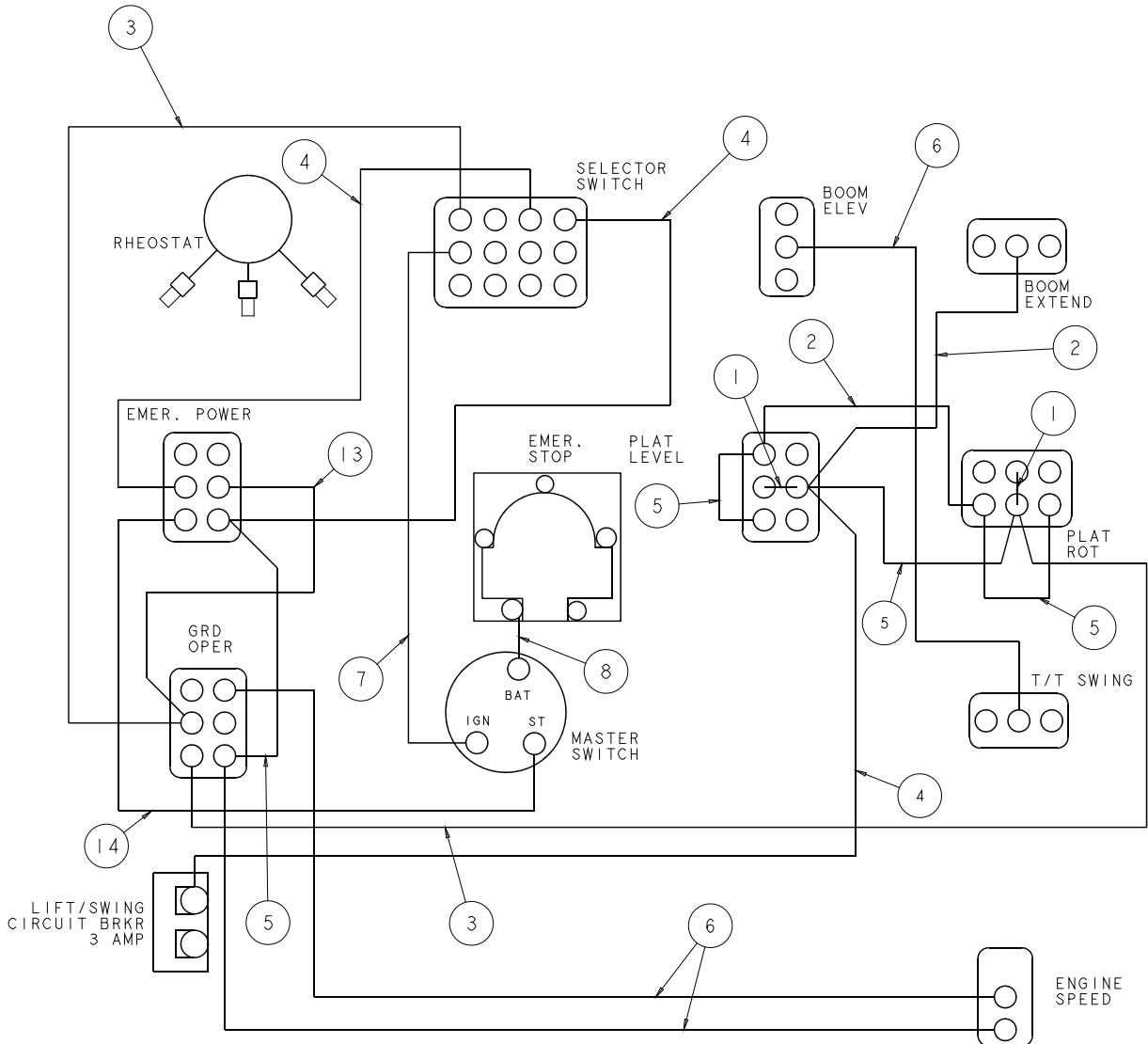
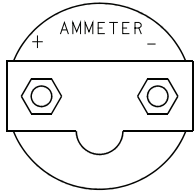

0112976

# Lower Controls – TB80

## Lower Controls – TB80

Item	Part No.	Qty.	Description
1	0060373	2	JUMPER, SWITCH TERMINAL STRAP
2	0070730	2	WIRE 16 R61 R61 5.5
3	0071588	2	WIRE 12 R61 R81 10
4	0070746	3	WIRE 16 R61 R61 9
5	0070747	4	WIRE 16 R61 R61 3
6	0070753	3	WIRE 16 R61 R61 12
7	0071541	1	WIRE 12 R61 R101 14
8	0070735	1	WIRE 12 R 61 R101 24
9	0074592	1	WLDMT GROUND CONTROL PANEL AND HINGE
10	0082002	1	RHEOSTAT SUB ASSEMBLY
11	0112559	1	PLACRAD GROUND CONTROL
12	3020020	1	SWITCH EMERGENCY STOP PUSH/PULL
13	0181104	1	WIRE 12 R6 R6 6
14	0240483	1	WIRE 16 R61 R101 8
15	3020013	1	SWITCH TOGGLE SPST ON OFF SEALED
16	3020016	3	SWITCH TOGGLE SPDT (ON) OFF (ON)
17	3020018	3	SWITCH TOGGLE DPDT (ON) OFF (ON)
18	3020087	1	KEY SWITCH SINGLE CODE
19	3020048	1	SWITCH TOGGLE 4PDT (ON/ON) SELAED
20	3020081	2	SWITCH TOGGLE DPDT (M/NONE/ON) SEALED
21	3040348	1	KNOB RHEOSTAT
22	3040535	1	CIRCUIT BREAKER 3AMP
23	3070003	1	AMMETER
24	5560004	1	NUT, 1/4-20 ESNA
25	5093006	1	CLAMP, CUSHION #15 (15/16)
26		1	CAPSCREW 1/4-20 X 3/4 LG HH
27	986019	1	WASHER 1/4 FLAT
28	300489	1	TERMINAL STRIP #10 STUD 6 CIR
29	5560673	2	SCREW THREAD #10-24 1.00
30	5560034	2	NUT LOCKING #10-24

## Lower Controls – TB80



## Lower Controls, Cummins – TB80

Item	Part No.	Qty.	Description
1	0112976	1	LOWER CONTROL PANEL
2	3070040	1	TEMPERATURE GAUGE
3	0083300	1	EPS WIRE ASSEMBLY
4	0112414	1	ENGINE WIRE ASSEMBLY

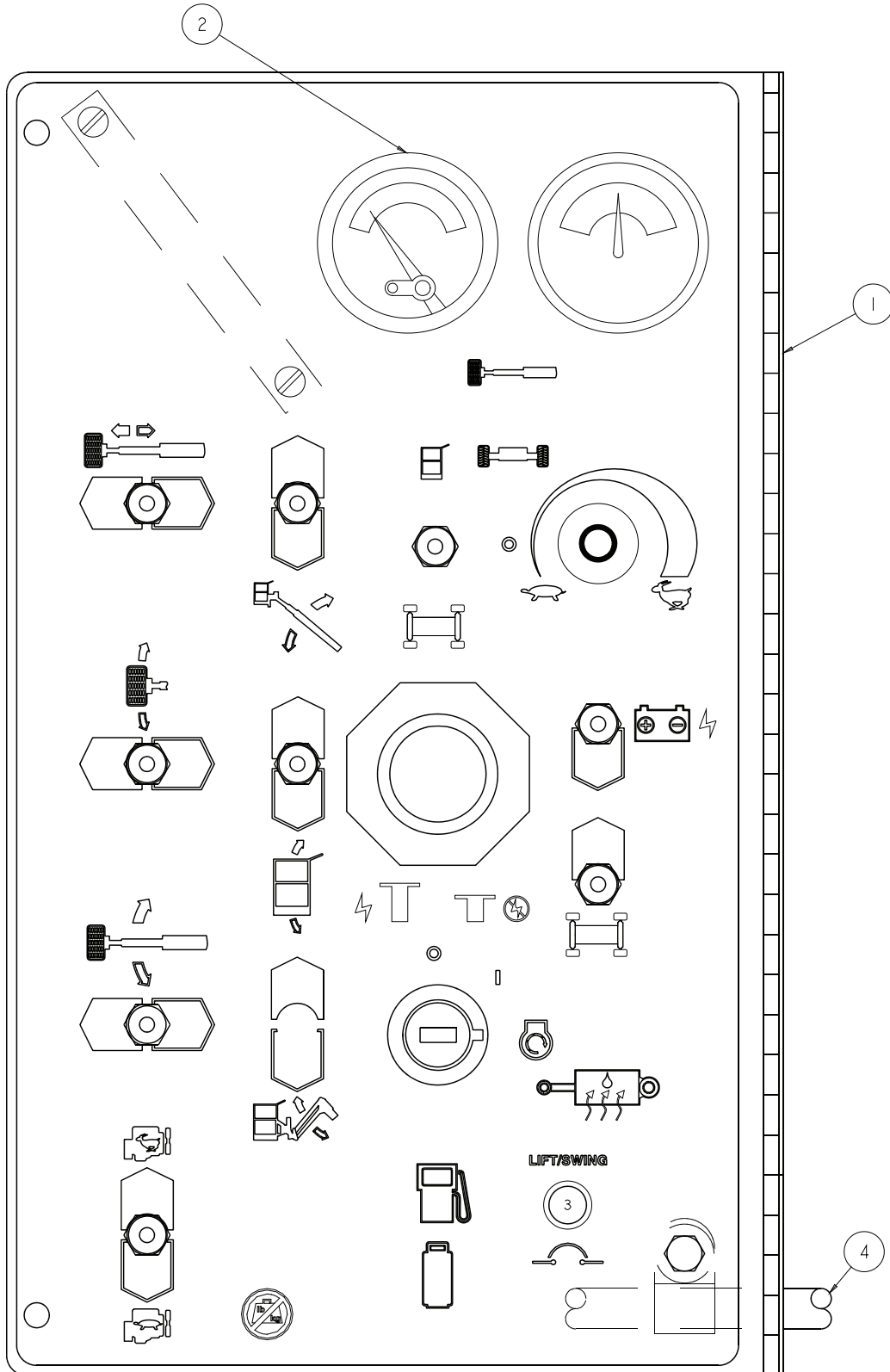

## Lower Controls, Cummins – TB80

0112856

# Lower Controls, Cummins – TB80

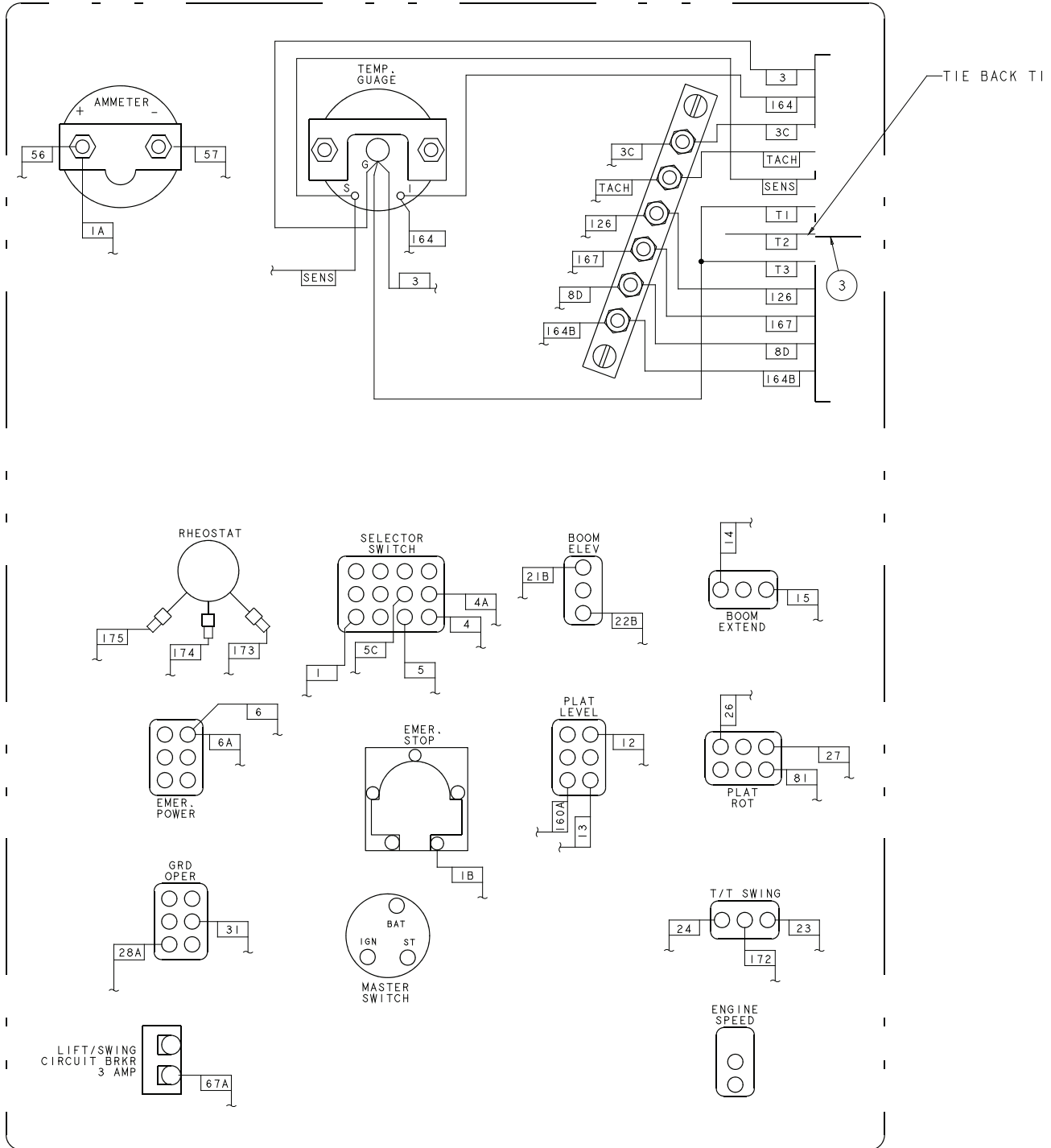

**NOTES:**

- 1. TIE BACK UNUSED WIRES 11, 11B, 118, 1551 FROM ENGINE WIRE ASSY.

NOTE 1

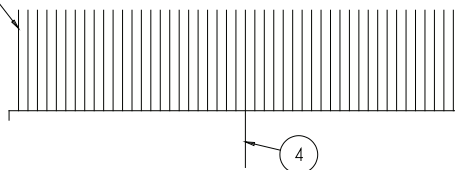

0112758

# Lower Controls, Cummins – TB80

## Lower Controls, Deutz – TB80

Item	Part No.	Qty.	Description
1	0112976	1	LOWER CONTROL PANEL
2	3070041	1	TEMPERATURE GAUGE
3	0083300	1	EPS WIRE ASSEMBLY
4	0112167	1	ENGINE WIRE ASSEMBLY

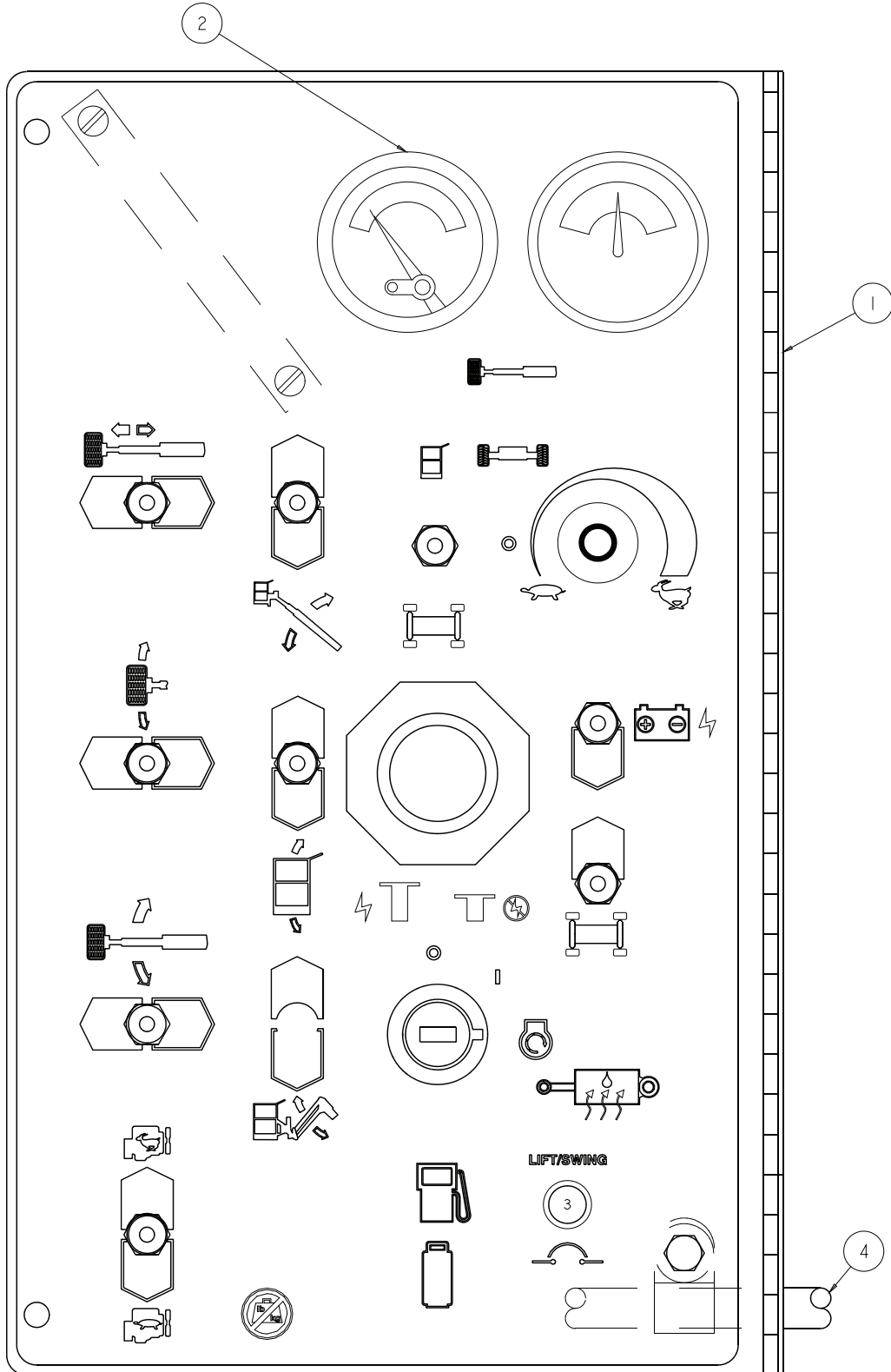

## Lower Controls, Deutz – TB80

0112857

# Lower Controls, Deutz – TB80

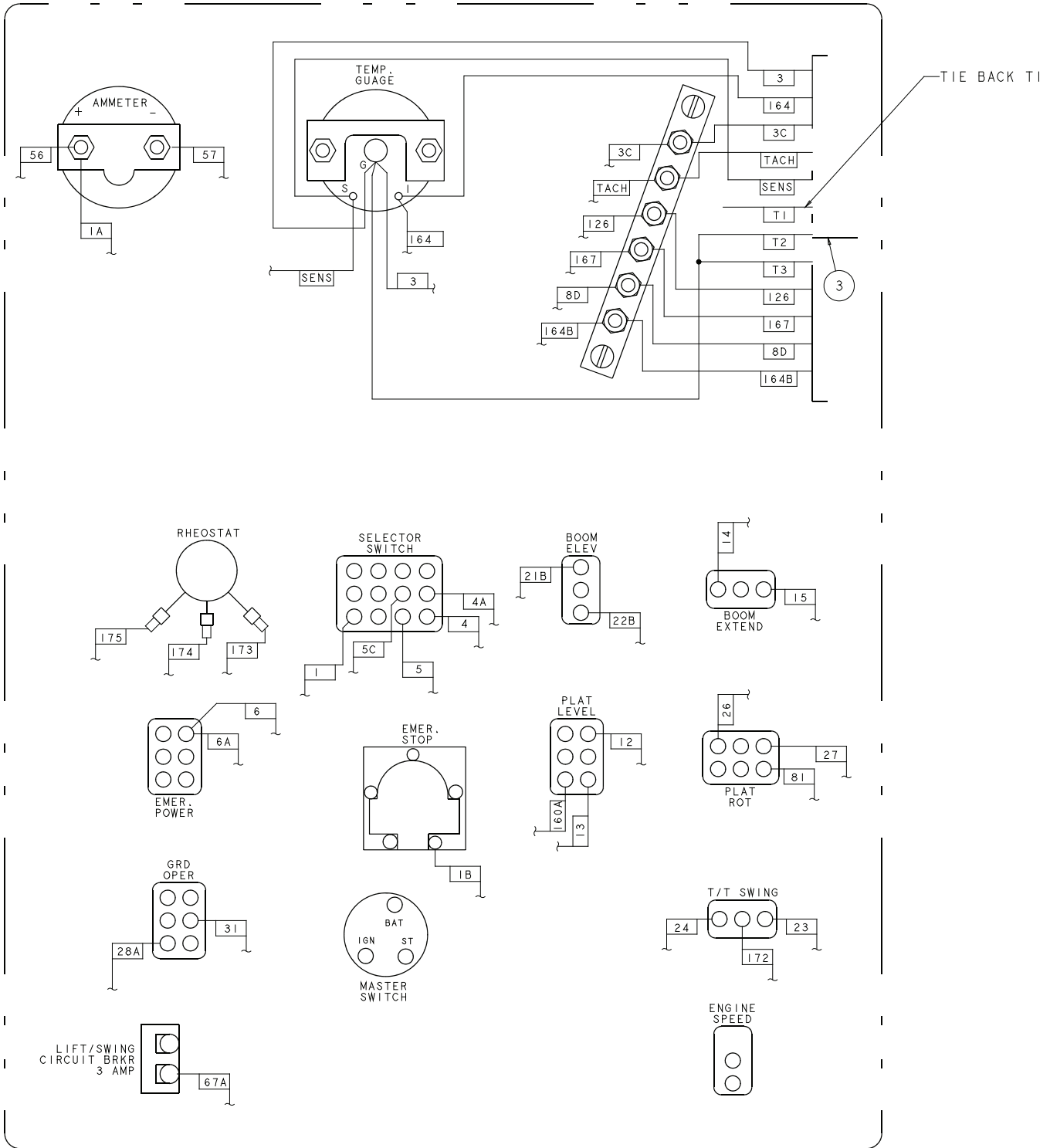

NOTE 1

**NOTES:**

1. TIE BACK UNUSED WIRES 11, 11B, 118, 1551 FROM ENGINE WIRE ASSY.

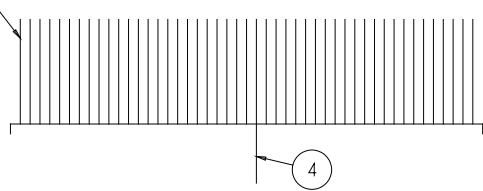

0112857

# Lower Controls, Deutz – TB80



# Lower Controls – TB85J

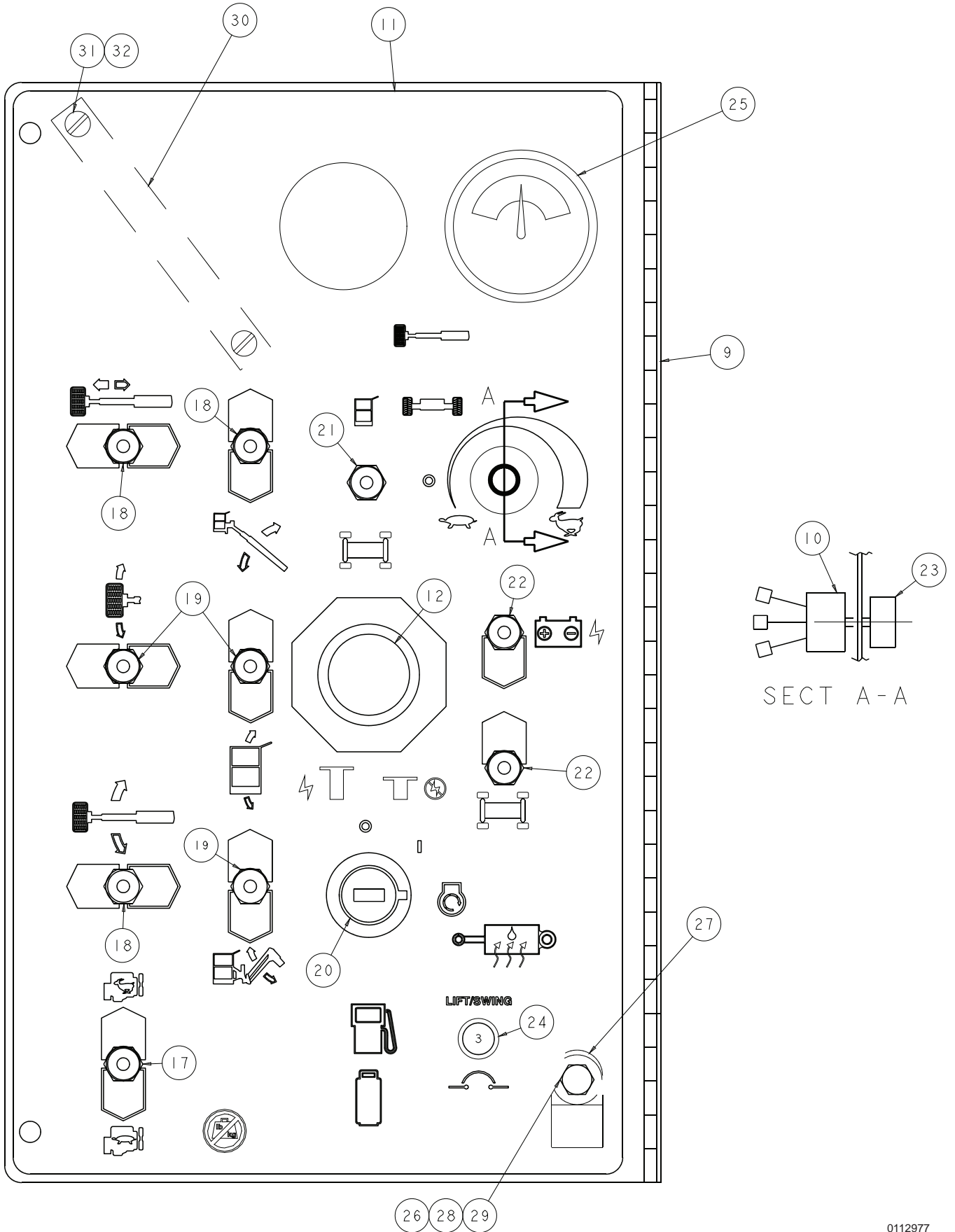

# Lower Controls – TB85J

# Lower Controls – TB85J

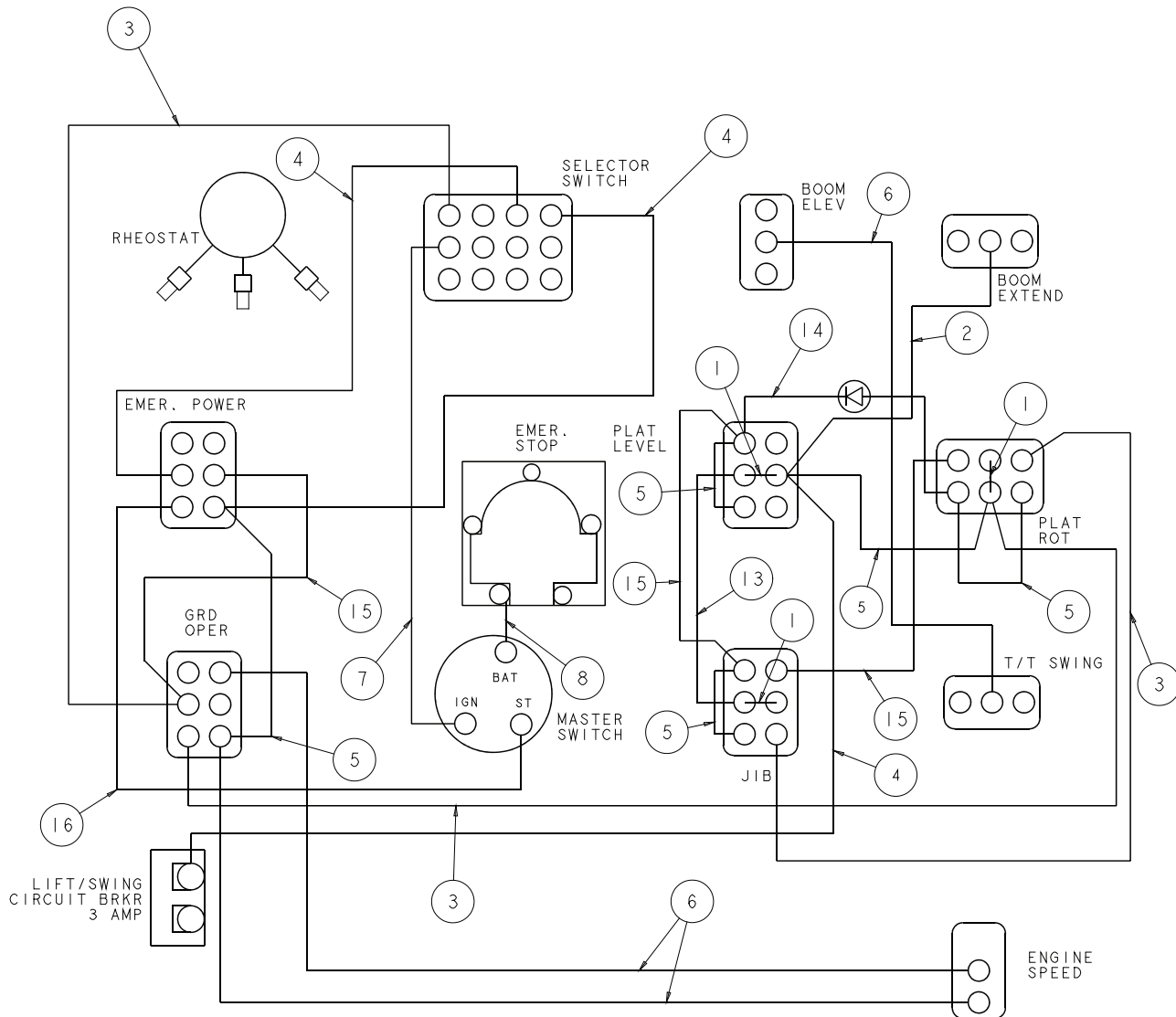
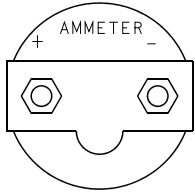

0112977

# Lower Controls – TB85J

## Lower Controls – TB85J

Item	Part No.	Qty.	Description
1	0060373	3	JUMPER, SWITCH TERMINAL STRAP
2	0070730	1	WIRE 16 R61 R61 5.5
3	0071588	3	WIRE 12 R61 R81 10
4	0070746	3	WIRE 16 R61 R61 9
5	0070747	5	WIRE 16 R61 R61 3
6	0070753	3	WIRE 16 R61 R61 12
7	0071541	1	WIRE 12 R61 R101 14
8	0070735	1	WIRE 12 R 61 R101 24
9	0074592	1	WLDMT GROUND CONTROL PANEL AND HINGE
10	0082002	1	RHEOSTAT SUB ASSEMBLY
11	0112559	1	PLACARD GROUND CONTROL
12	3020020	1	SWITCH EMERGENCY STOP PUSH/PULL
13	0070742	1	WIRE 12 R61 R61 8-REV K
14	0111477	1	WIRE 16 R61 R61 10 DIO
15	0181104	3	WIRE 12 R6 R6 6
16	0240483	1	WIRE 16 R61 R101 8
17	3020013	1	SWITCH TOGGLE SPST ON OFF SEALED
18	3020016	3	SWITCH TOGGLE SPDT (ON) OFF (ON)
19	3020018	3	SWITCH TOGGLE DPDT (ON) OFF (ON)
20	3020087	1	KEY SWITCH SINGLE CODE
21	3020048	1	SWITCH TOGGLE 4PDT (ON/ON) SELAED
22	3020081	2	SWITCH TOGGLE DPDT (M/NONE/ON) SEALED
23	3040348	1	KNOB RHEOSTAT
24	3040535	1	CIRCUIT BREAKER 3AMP
25	3070003	1	AMMETER
26	5560004	1	NUT, 1/4-20 ESNA
27	5093006	1	CLAMP, CUSHION #15 (15/16)
28		1	CAPSCREW 1/4-20 X 3/4 LG HH
29	986019	1	WASHER 1/4 FLAT
30	300489	1	TERMINAL STRIP #10 STUD 6 CIR
31	5560673	2	SCREW THREAD #10-24 1.00
32	5560034	2	NUT LOCKING #10-24

## Lower Controls – TB85J



## Lower Controls, Cummins – TB85J

Item	Part No.	Qty.	Description
1	0112977	1	LOWER CONTROL PANEL
2	3070040	1	TEMPERATURE GAUGE
3	0083300	1	EPS WIRE ASSEMBLY
4	0112414	1	ENGINE WIRE ASSEMBLY

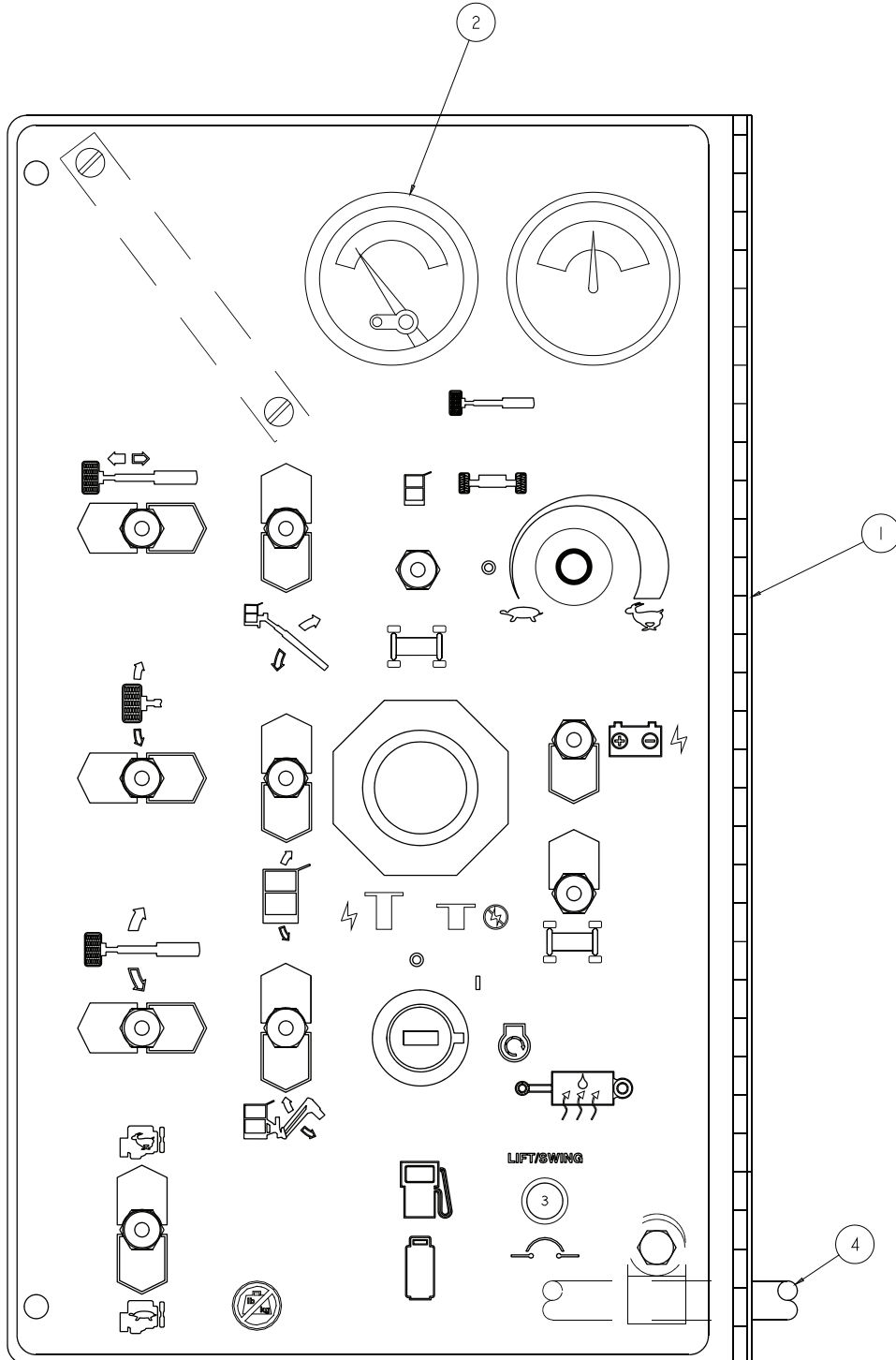

0112745

## Lower Controls, Cummins – TB85J

# Lower Controls, Cummins – TB85J

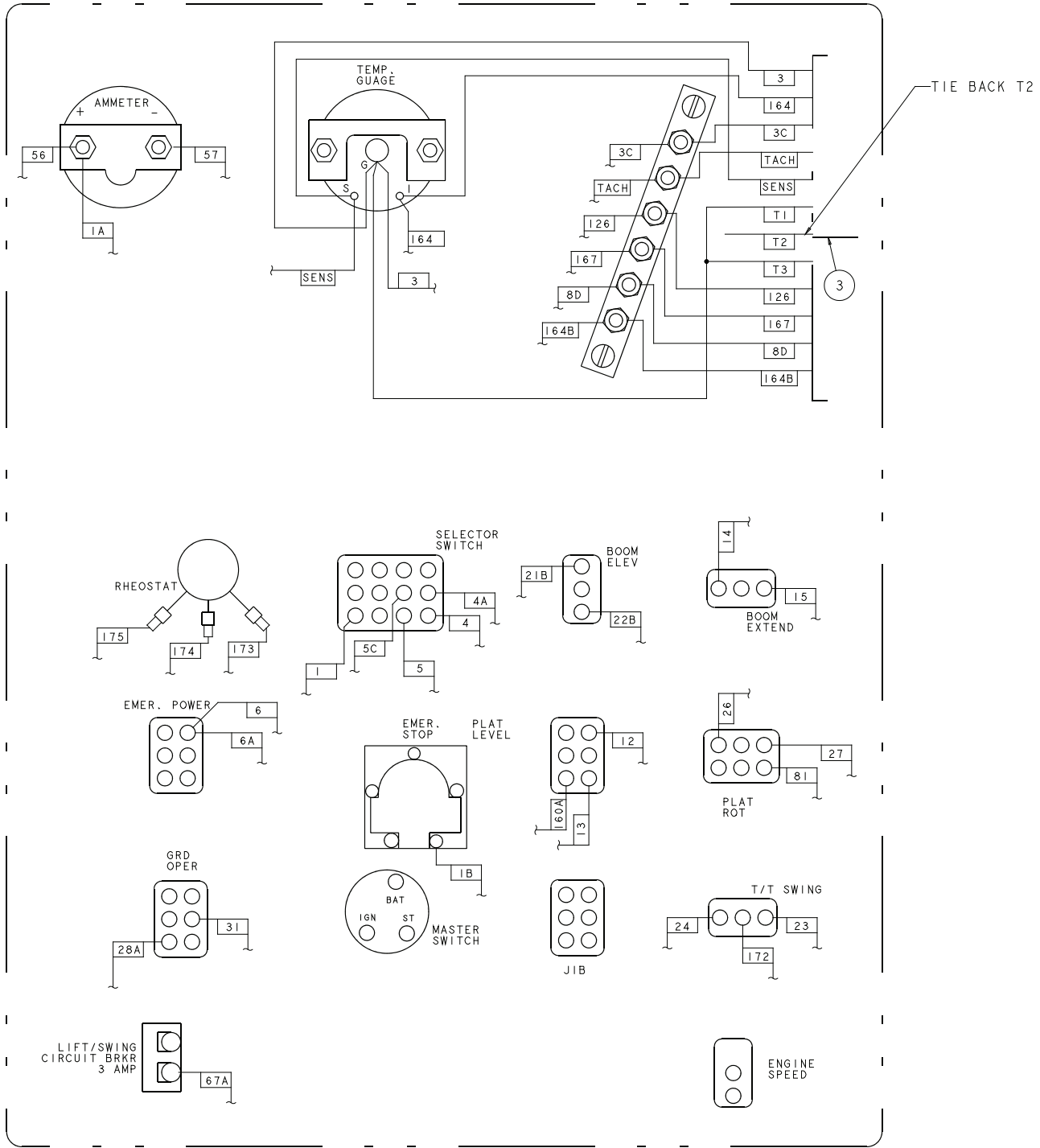

**NOTES:**

- 1. TIE BACK UNUSED WIRES 11, 11B, 118, 155 FROM ENGINE WIRE ASSY.

NOTE 1

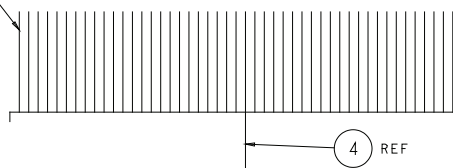

0112745

# Lower Controls, Cummins – TB85J

## Lower Controls, Deutz – TB85J

Item	Part No.	Qty.	Description
1	0112977	1	LOWER CONTROL PANEL
2	3070041	1	TEMPERATURE GAUGE
3	0083300	1	EPS WIRE ASSEMBLY
4	0112167	1	ENGINE WIRE ASSEMBLY

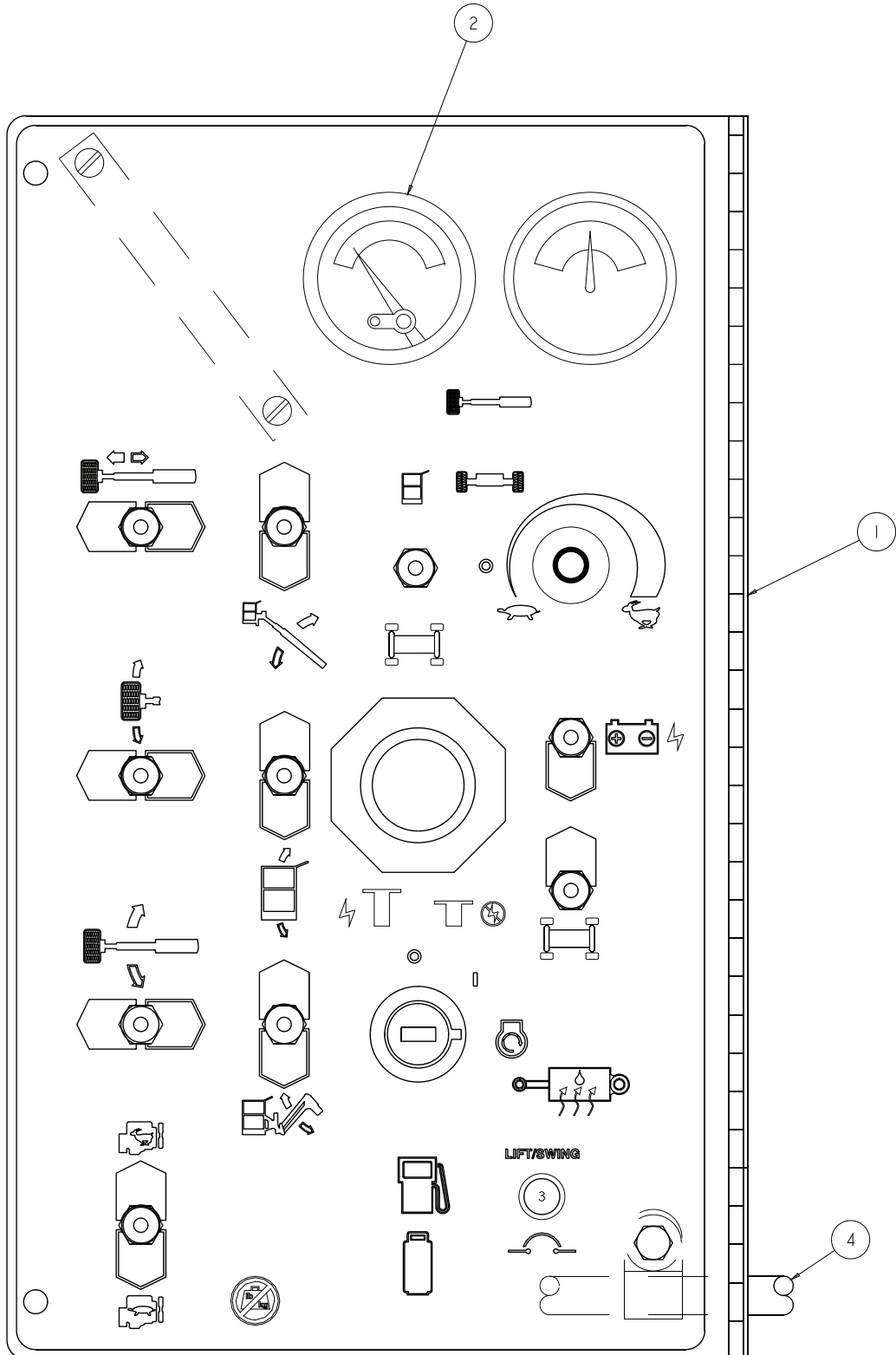

0112758

## Lower Controls, Deutz – TB85J

# Lower Controls, Deutz – TB85J

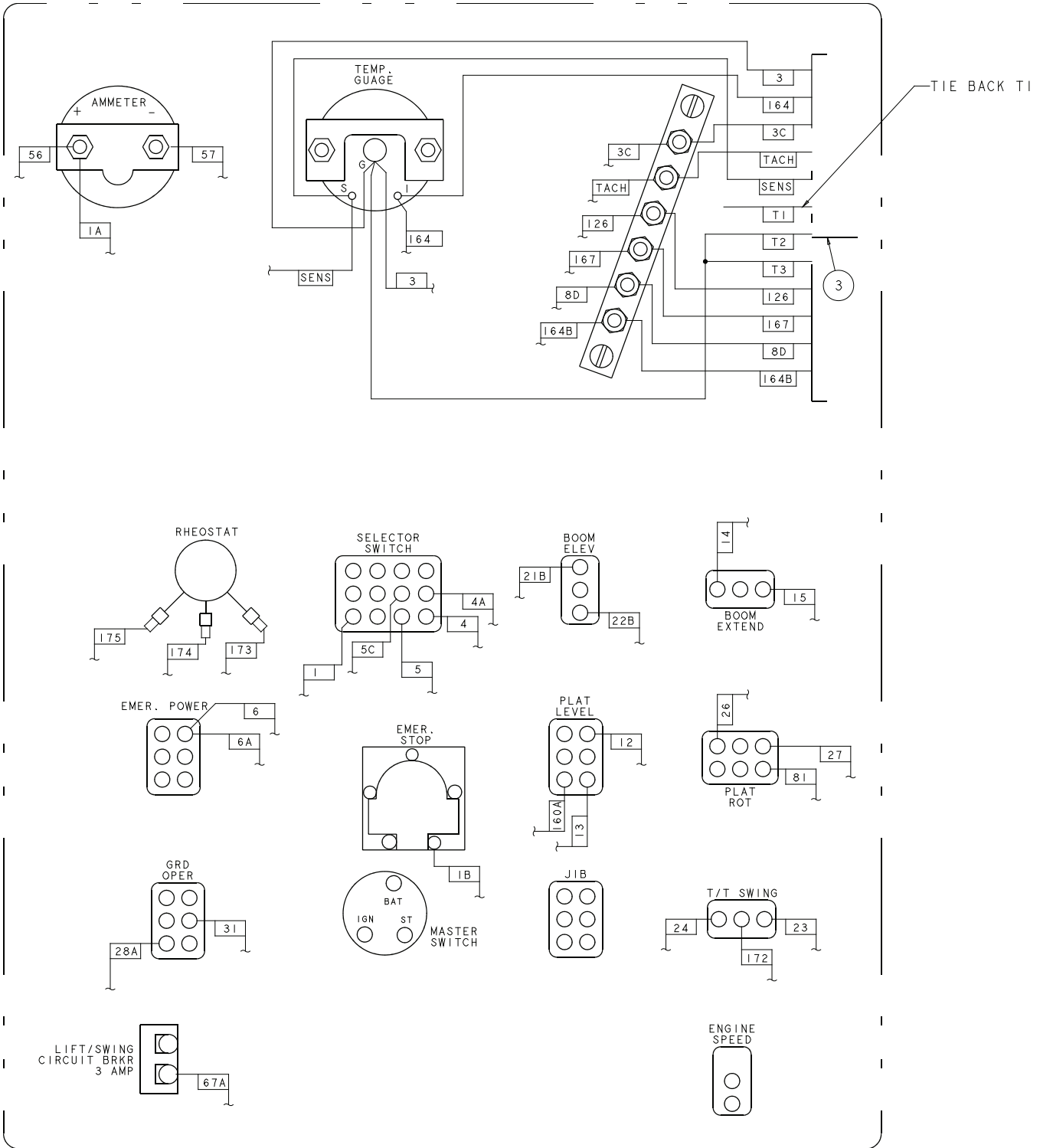

NOTE 1

**NOTES:**

1. TIE BACK UNUSED WIRES 11, 11B, 118, 155 FROM ENGINE WIRE ASSY.

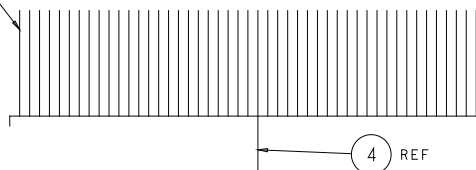

0112758

# Lower Controls, Deutz – TB85J



# Lower Controls, GM – TB85J

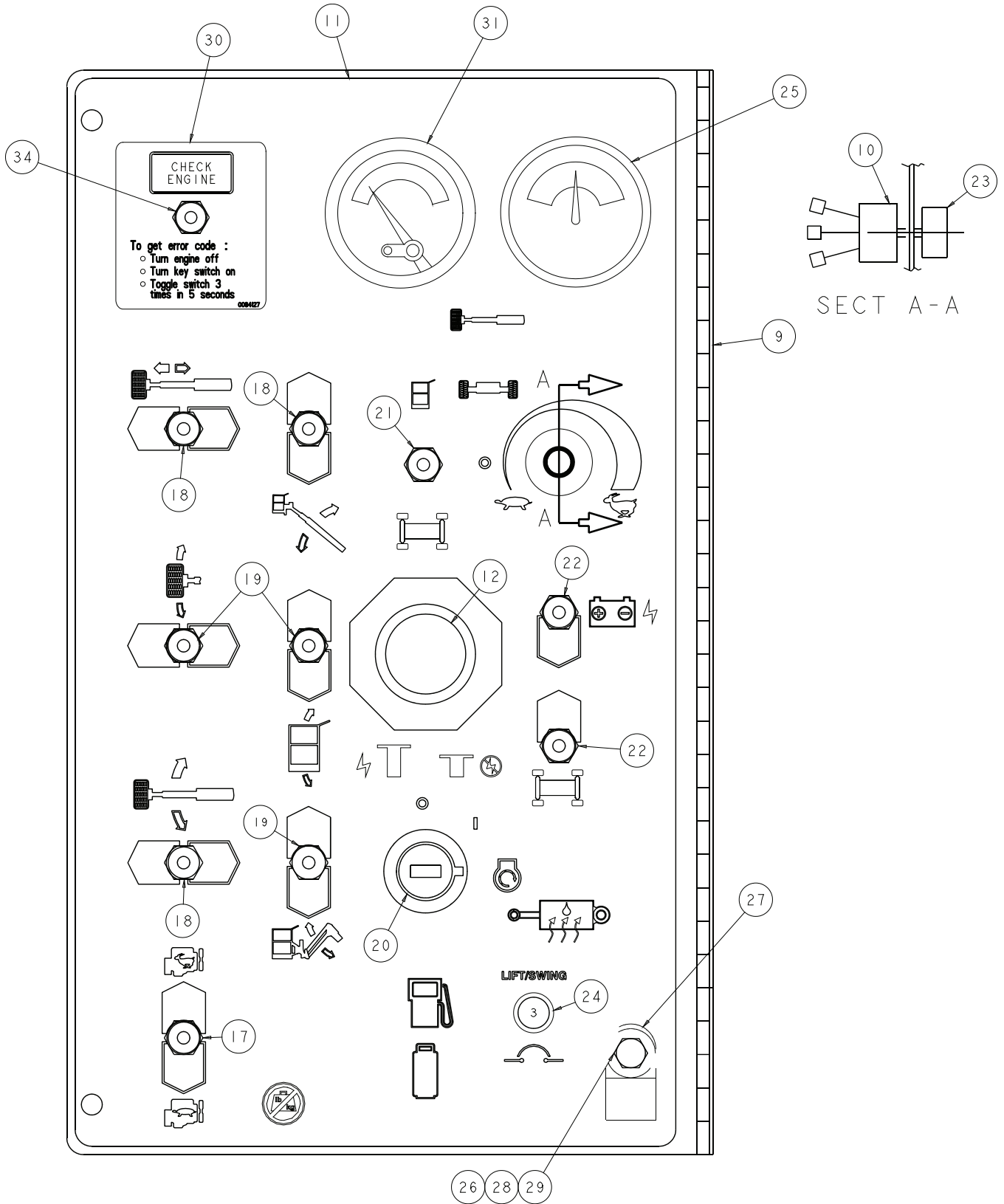

# Lower Controls, GM – TB85J

# Lower Controls, GM – TB85J

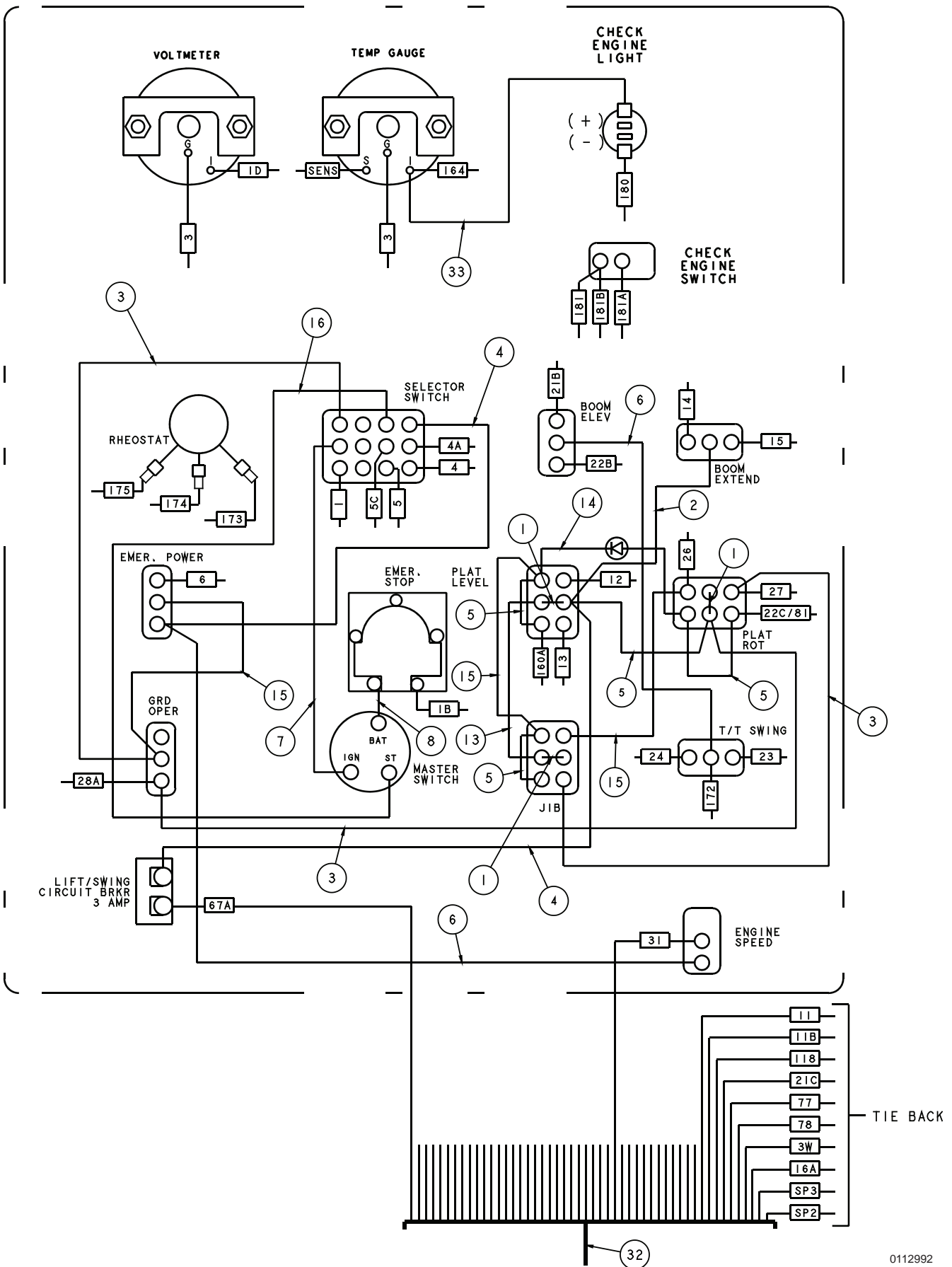

# Lower Controls, GM – TB85J

## Lower Controls, GM – TB85J

Item	Part No.	Qty.	Description
1	0060373	3	JUMPER, SWITCH TERMINAL STRAP
2	0070730	1	WIRE 16 R61 R61 5.5
3	0071588	2	WIRE 12 R61 R81 10
4	0070746	3	WIRE 16 R61 R61 9
5	0070747	4	WIRE 16 R61 R61 3
6	0070753	2	WIRE 16 R61 R61 12
7	0071541	1	WIRE 12 R61 R101 14
8	0070735	1	WIRE 12 R 61 R101 24
9	0074592	1	WLDMT GROUND CONTROL PANEL AND HINGE
10	0082002	1	RHEOSTAT SUB ASSEMBLY
11	0112559	1	PLACARD GROUND CONTROL
12	3020020	1	SWITCH EMERGENCY STOP PUSH/PULL
13	0070742	1	WIRE 12 R61 R61 8-REV K
14	0111477	1	WIRE 16 R61 R61 10 DIO
15	0181104	3	WIRE 12 R6 R6 6
16	0151910	1	WIRE 16 R61 R101 14
17	3020013	1	SWITCH TOGGLE SPST ON OFF SEALED
18	3020016	3	SWITCH TOGGLE SPDT (ON) OFF (ON)
19	3020018	3	SWITCH TOGGLE DPDT (ON) OFF (ON)
20	3020087	1	KEY SWITCH SINGLE CODE
21	3020048	1	SWITCH TOGGLE 4PDT (ON/ON) SELAED
22	3020080	2	SWITCH TOGGLE
23	3040348	1	KNOB RHEOSTAT
24	3040535	1	CIRCUIT BREAKER 3AMP
25	3072126	1	VOLTMETER
26	5560004	1	NUT, 1/4-20 ESNA
27	5093006	1	CLAMP, CUSHION #15 (15/16)
28		1	CAPSCREW 1/4-20 X 3/4 LG HH
29	986019	1	WASHER 1/4 FLAT
30	0084127	1	PLACARD, CHECK ENGINE
31	3070040	1	TEMP GAUGE
32	0084101	1	ENGINE WIRE ASSEMBLY
33	300804	1	WIRE 18 R81 F250FI 6
34	3020015	1	SWITCH TOGGLE SPST MAIN/MOM

## Lower Controls, GM – TB85J



# Lower Controls, CE – TB85J

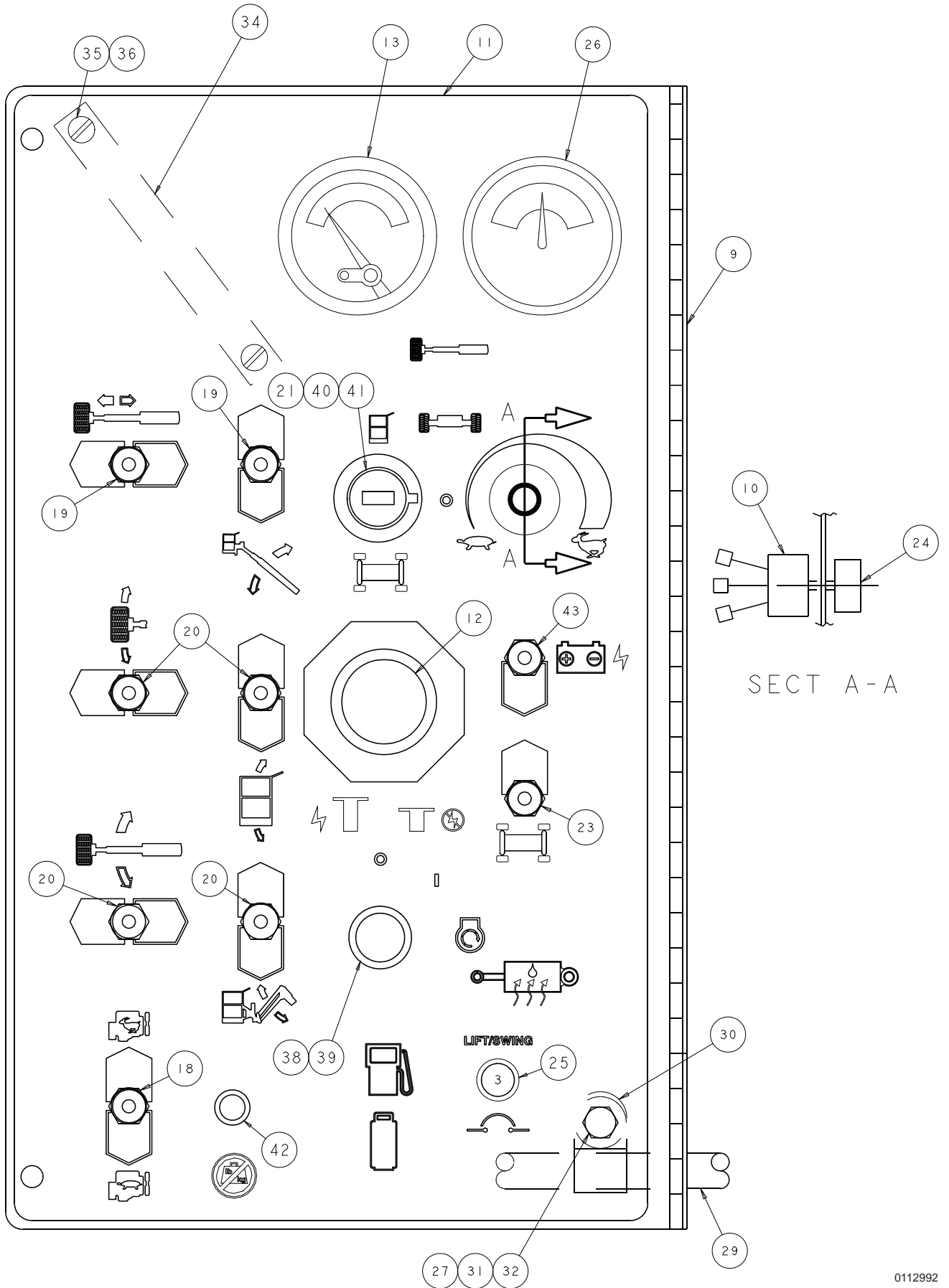

# Lower Controls, CE – TB85J

# Lower Controls, CE – TB85J

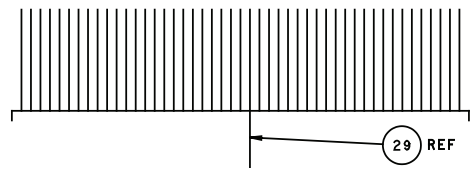
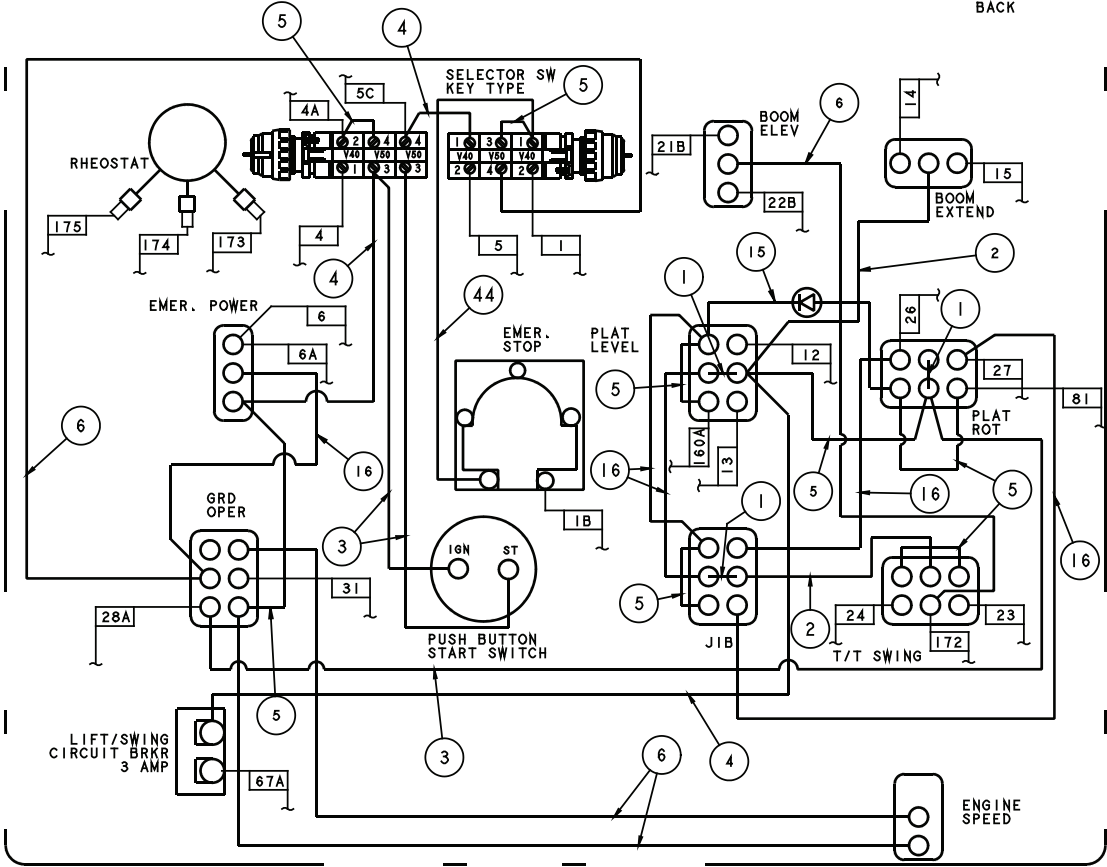
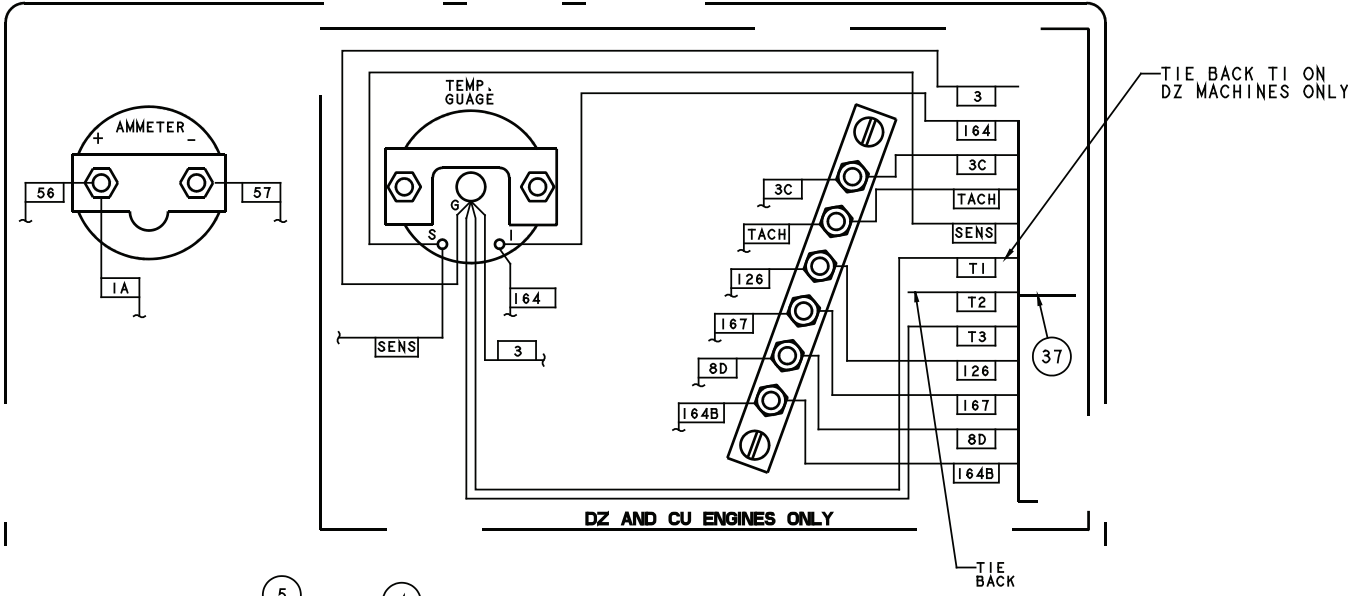

0112992

# Lower Controls, CE – TB85J

## Lower Controls, CE – TB85J

Item	Part No.	Qty.	Description
1	0060373	3	JUMPER, SWITCH TERMINAL STRAP
2	0070730	2	WIRE 16 R61 R61 5.5
3	0071588	3	WIRE 12 R61 R81 10
4	0070746	3	WIRE 16 R61 R61 9
5	0070747	8	WIRE 16 R61 R61 3
6	0070753	4	WIRE 16 R61 R61 12
9	0074592	1	WLDMT GROUND CONTROL PANEL AND HINGE
10	0082002	1	RHEOSTAT SUB ASSEMBLY
11	0112559	1	PLACARD GROUND CONTROL
12	3020020	1	SWITCH EMERGENCY STOP PUSH/PULL
13	3070041	1	TEMPERATURE GAUGE - DUETZ ENGINE
	3070040	1	TEMPERATURE GAUGE - CUMMINS ENGINE
	3070021	1	TEMPERATURE GAUGE - GM ENGINE
15	0111477	1	WIRE 16 R61 R61 10 DIO
16	0181104	5	WIRE 12 R6 R6 6
17	3020013	1	SWITCH TOGGLE SPST ON OFF SEALED
19	3020016	2	SWITCH TOGGLE SPDT (ON) OFF (ON)
20	3020018	4	SWITCH TOGGLE DPDT (ON) OFF (ON)
21	3020070	1	KEYED SELECTOR CE ON N ON
23	3020081	1	SWITCH TOGGLE
24	3040348	1	KNOB RHEOSTAT
25	3040535	1	CIRCUIT BREAKER 3AMP
26	3070003	1	AMMETER
27	5560004	1	NUT, 1/4-20 ESNA
29	0112167	1	ENGINE WIRE ASSEMBLY - DUETZ ENGINE
	0112414	1	ENGINE WIRE ASSEMBLY - CUMMINS ENGINE
	0083922	1	ENGINE WIRE ASSEMBLY - GM ENGINE
30	5093006	1	CLAMP, CUSHION #15 (15/16)
31	975089	1	CAPSCREW 1/4-20 X 3/4 LG HH
32	986019	1	WASHER 1/4 FLAT
34	300489	1	TERMINAL STRIP #10 STUD 6 CIR
35	5560673	2	SCREW THRD #10-24 1.00
36	5560034	2	NUT LKG #10-24
37	0083300	1	EPS WIRE ASSEMBLY
38	3026027	1	SWITCH PUSH BUTTON
39	7140093	1	SEAL KIT
40	3020068	3	CONTACT BLOCK (CCW-ON)
41	3020069	3	CONTACT BLOCK (CW-ON)
42	3069524	1	LIGHT, RED LED 12V .64 DIA
43	3020080	1	SWITCH TOGGLE
44	0070742	1	WIRE 12 R6I R6I 8

## Lower Controls, CE – TB85J





F

E

D

C

B

A

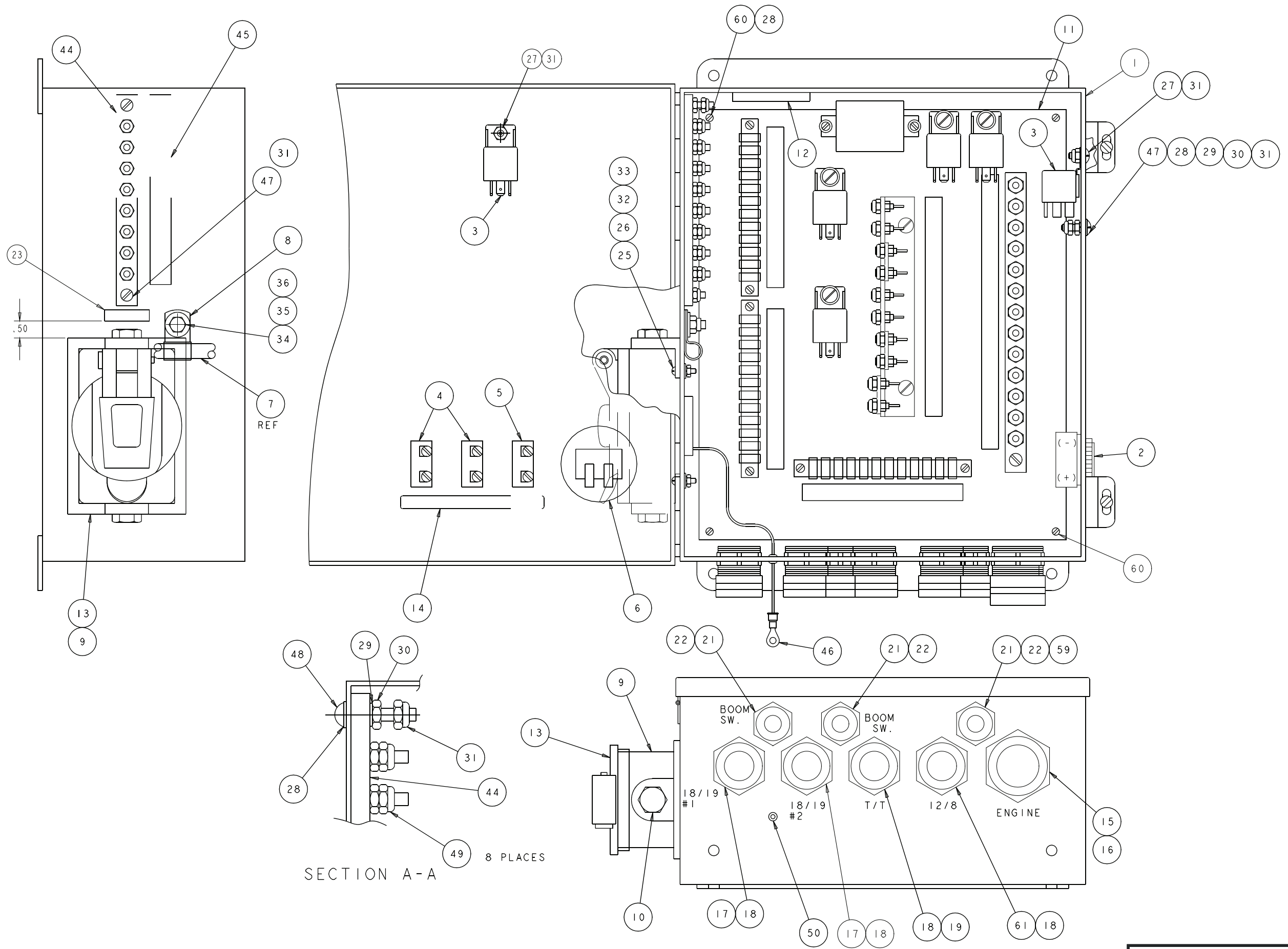

F  
E  
D  
C  
B  
A

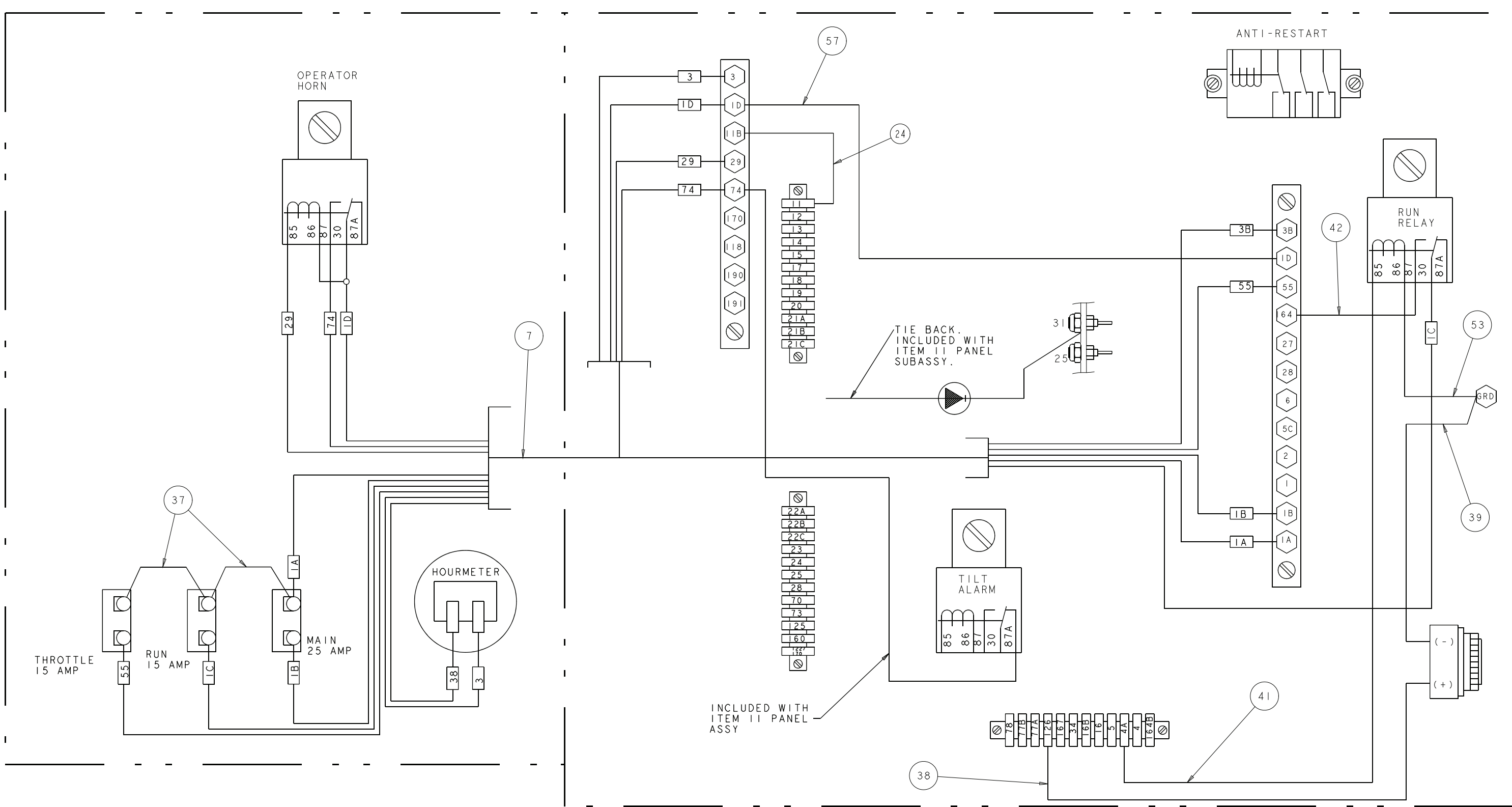

## Wiring Box Assembly – Cummins, Deutz and CE

Item	Part No.	Qty.	Description
1	0111872	1	WIRING BOX
2	3040411	1	MINI SIREN
3	3040469	2	RELAY
4	3040252	2	CIRCUIT BREAKER
5	3040069	1	CIRCUIT BREAKER
6	3070001	1	HOURMETER
7	0112784	1	INTERNAL WIRE ASSEMBLY
8	5093002	1	CLAMP
9	3040118	1	EXTENSION W/GASKET
10	3040121	2	CLOSE-UP PLUG
11	0112165	1	PANEL SUB ASSEMBLY
12	0070967	1	CORROSION INHIBITOR, STICK-BACK
13	3045278	1	OUTLET
14	0111735	1	PLACARD, CIRCUIT BREAKER
15	3040386	1	CONNECTOR
16	3070387	1	NUT, CONDUIT LOCKNUT 1" HUB
17	3040116	2	3/4 CABLE CONNECTOR
18	3040110	4	NUT, CONDUIT LOCKNUT 3/4" HUB
19	3040298	1	CONNECTOR
21	3040187	3	CABLE CONNECTOR
22	3040070	3	NUT, CONDUIT LOCKNUT 1/2" HUB
23	0150606	1	DECAL 125V 15 AMP
24	0071552	1	WIRE 16 R101 FEM1881 7
25	974239	6	SCREW RHD 6-32 X .50 PLATED
26	984009	6	NUT #6-32 HEX PLATED
27		6	#10-24 X 1/2 LG TRUSS HD
28		3	WASHER #10 STAR
29	5560654	2	WASHER #10 LOCK
30	984049	2	NUT #10-24 HEX
31	5560034	7	NUT #10-24 ESNA
32	986159	4	WASHER #6 FLAT
33	987349	4	WASHER #6 LOCK
34	986019	1	WASHER 1/4" FLAT
35	970029	1	BOLT HEXHD .25-20 X .75 GR5
36	5560004	1	NUT 1/4-20 ESNA
37	0070735	2	JUMPER WIRE
38	0181028	1	JUMPER WIRE
39	0240483	1	WIRE ASSEMBLY
41	0071528	1	JUMPER WIRE
42	0073057	1	JUMPER WIRE
44	3044708	1	TERMINAL STRIP, #10 STUD, 8 POST
45	0112783	1	DECAL, TERMINAL STRIP
46	0071561	1	JUMPER WIRE
47	974689	2	SCREW RHD #10-24 X .75 PLATED
48	974709	1	SCREW RHD #10-24 X 1 PLATED
49	5560038	8	NUT #10-32 ESNA
50	5569003	1	GROMMET
53	0081559	1	JUMPER WIRE
57	0181815	1	JUMPER WIRE
59		1	BOLT HEXHD .375-18 1.00 GR5
60	5560701	4	SCREW RHD 10-32 .375
61	3070295	1	CONNECTOR .75 .625-.75

## Wiring Box Assembly – Cummins, Deutz and CE



SCRAPE PAINT FOR GOOD GRND

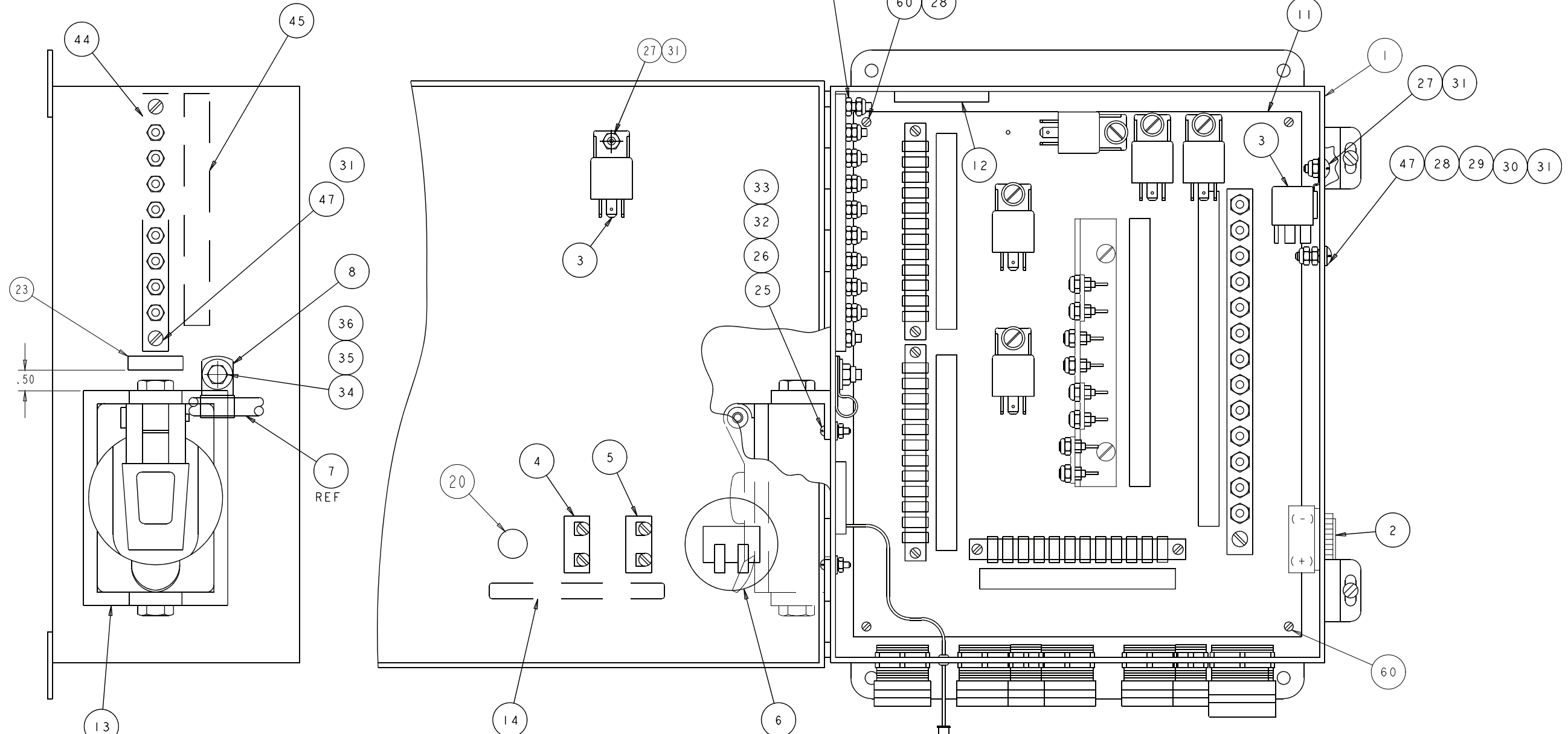

.50

7 REF

13 REF

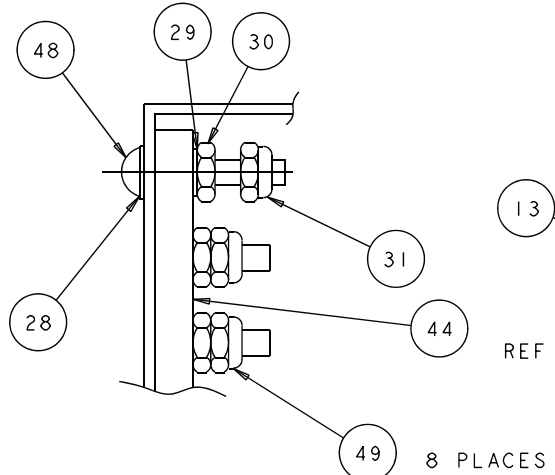

SECTION A-A

13 REF

8 PLACES

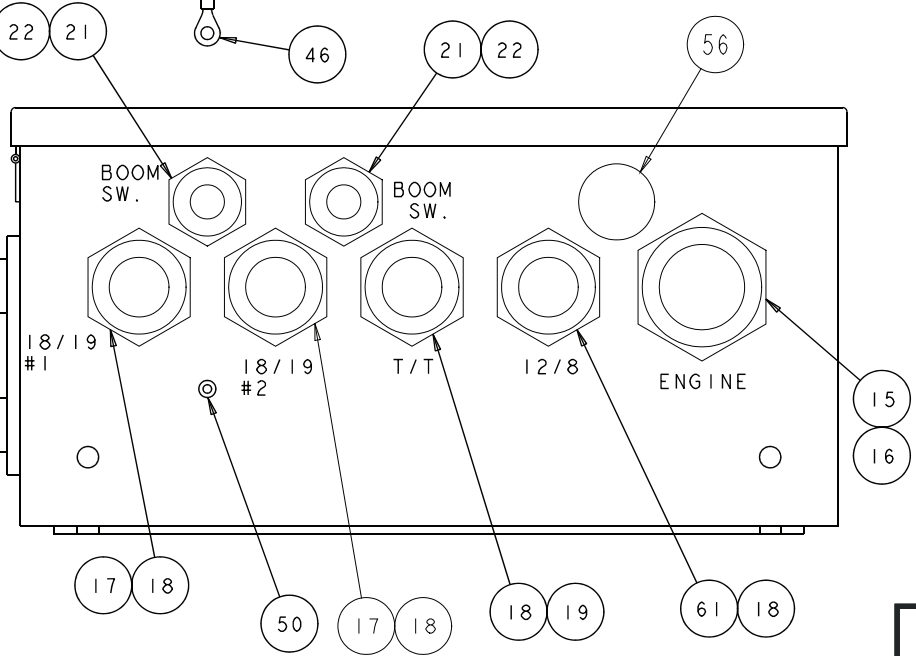

F  
E  
D  
C  
B  
A

1 2 3 4 5 6 7 8 9

F  
E  
D  
C  
B  
A

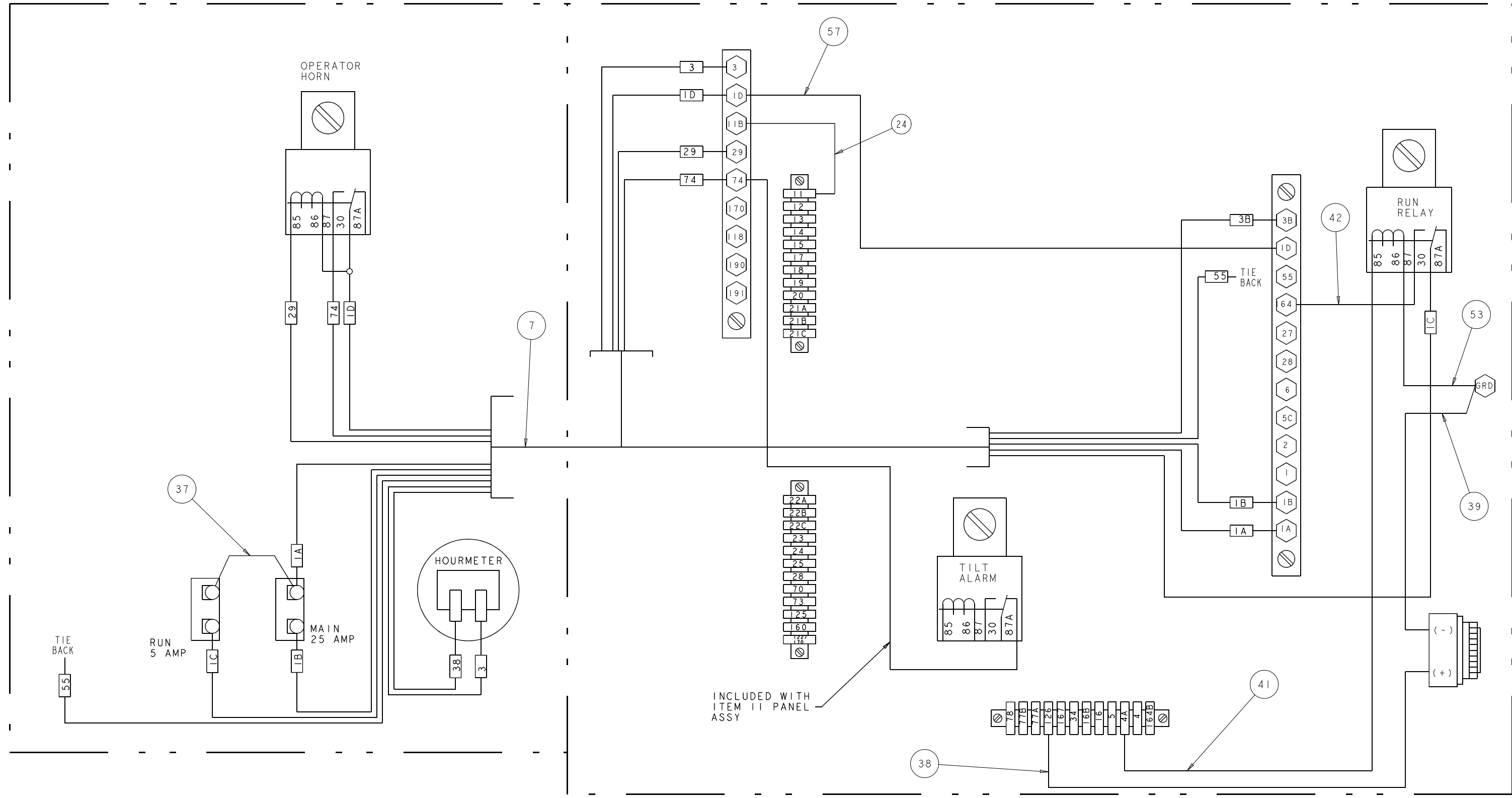

## Wiring Box Assembly – GM

Item	Part No.	Qty.	Description
1	0111872	1	WIRING BOX
2	3040411	1	MINI SIREN
3	3040469	2	RELAY
4	582206	1	CIRCUIT BREAKER
5	3040069	1	CIRCUIT BREAKER
6	3070001	1	HOURMETER
7	0112784	1	INTERNAL WIRE ASSEMBLY
8	5093002	1	CLAMP
9	3040118	1	EXTENSION W/GASKET
10	3040121	2	CLOSE-UP PLUG
11	0112165	1	PANEL SUB ASSEMBLY
12	0070967	1	CORROSION INHIBITOR, STICK-BACK
13	3045278	1	OUTLET
14	0111735	1	PLACARD, CIRCUIT BREAKER
15	3040386	1	CONNECTOR
16	3070387	1	NUT, CONDUIT LOCKNUT 1" HUB
17	3040116	2	3/4 CABLE CONNECTOR
18	3040110	4	NUT, CONDUIT LOCKNUT 3/4" HUB
19	3040298	1	CONNECTOR
20	469396	1	HOLE PLUG .500
21	3040187	2	CABLE CONNECTOR
22	3040070	2	NUT, CONDUIT LOCKNUT 1/2" HUB
23	0150606	1	DECAL 125V 15 AMP
24	0071552	1	WIRE 16 R101 FEM1881 7
25	974239	6	SCREW RHD 6-32 X .50 PLATED
26	984009	6	NUT #6-32 HEX PLATED
27		6	#10-24 X 1/2 LG TRUSS HD
28		3	WASHER #10 STAR
29	5560654	2	WASHER #10 LOCK
30	984049	2	NUT #10-24 HEX
31	5560034	7	NUT #10-24 ESNA
32	986159	4	WASHER #6 FLAT
33	987349	4	WASHER #6 LOCK
34	986019	1	WASHER 1/4" FLAT
35	970029	1	BOLT HEXHD .25-20 X .75 GR5
36	5560004	1	NUT 1/4-20 ESNA
37	0070735	1	JUMPER WIRE
38	0181028	1	JUMPER WIRE
39	0240483	1	WIRE ASSEMBLY
41	0071528	1	JUMPER WIRE
42	0073057	1	JUMPER WIRE
44	3044708	1	TERMINAL STRIP, #10 STUD, 8 POST
45	0112783	1	DECAL, TERMINAL STRIP
46	0071561	1	JUMPER WIRE
47	974689	2	SCREW RHD #10-24 X .75 PLATED
48	974709	1	SCREW RHD #10-24 X 1 PLATED
49	5560038	8	NUT #10-32 ESNA
50	5569003	1	GROMMET
53	0081559	1	JUMPER WIRE
56	3040301	1	HOLE PLUG .875
57	0181815	1	JUMPER WIRE
60	5560701	4	SCREW RHD 10-32 .375
61	3070295	1	CONNECTOR .75 .625-.75

## Wiring Box Assembly – GM





F

E

D

C

B

A

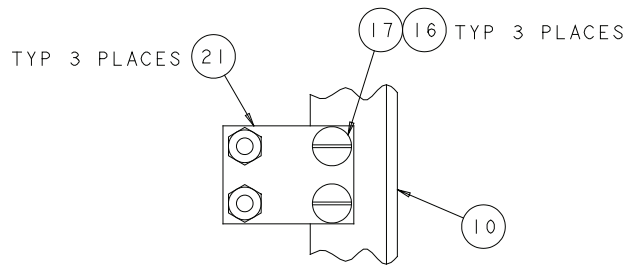
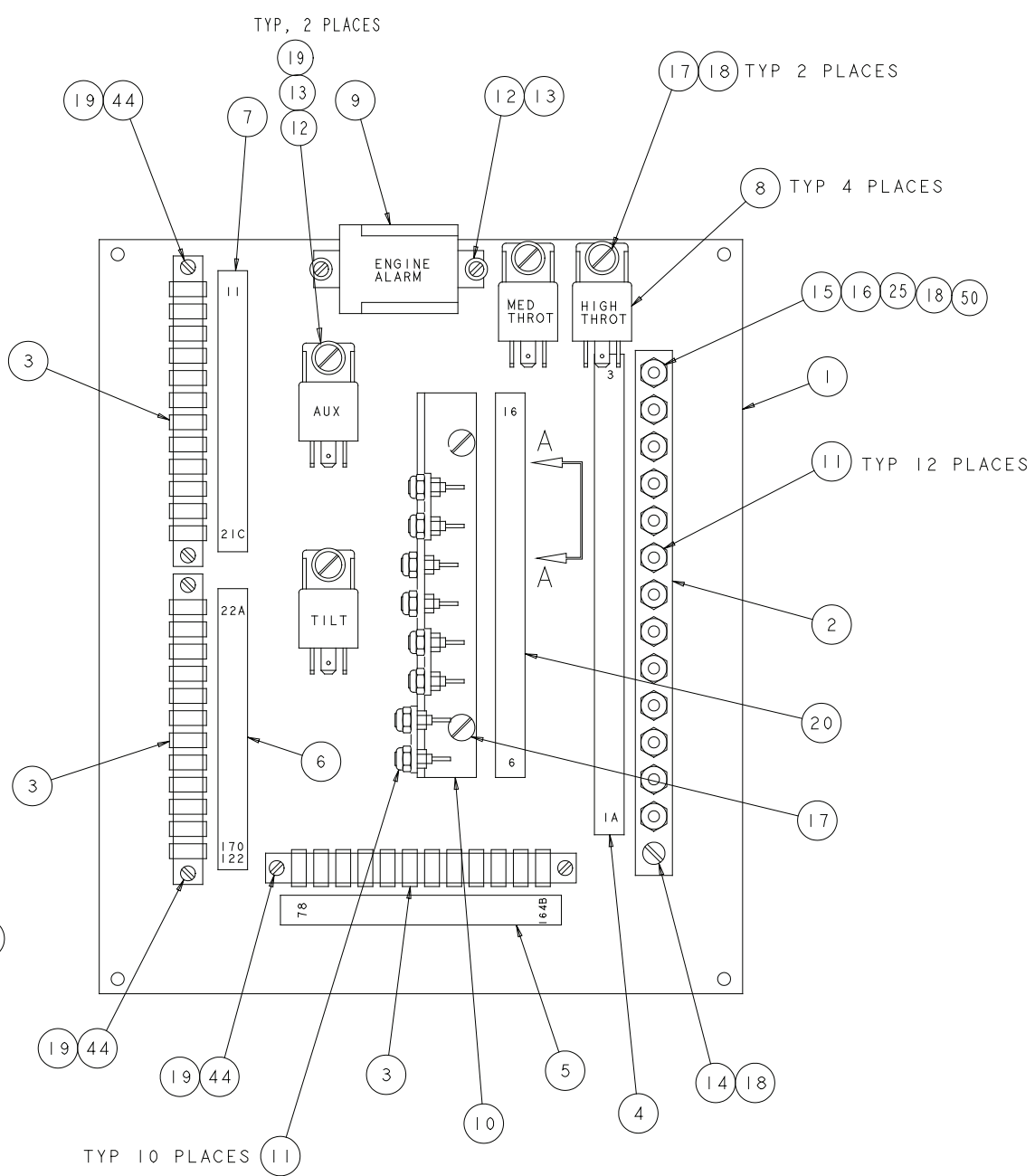
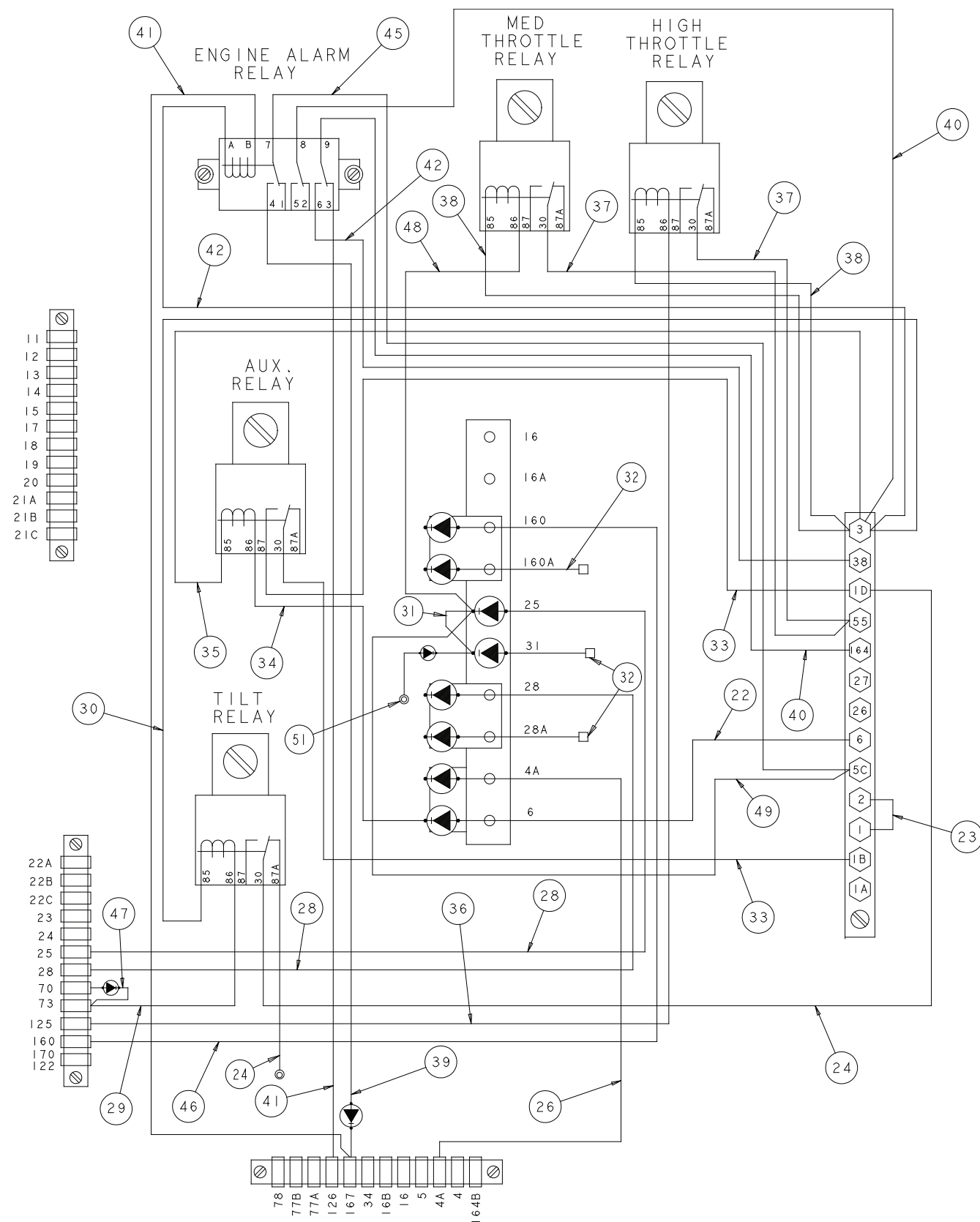

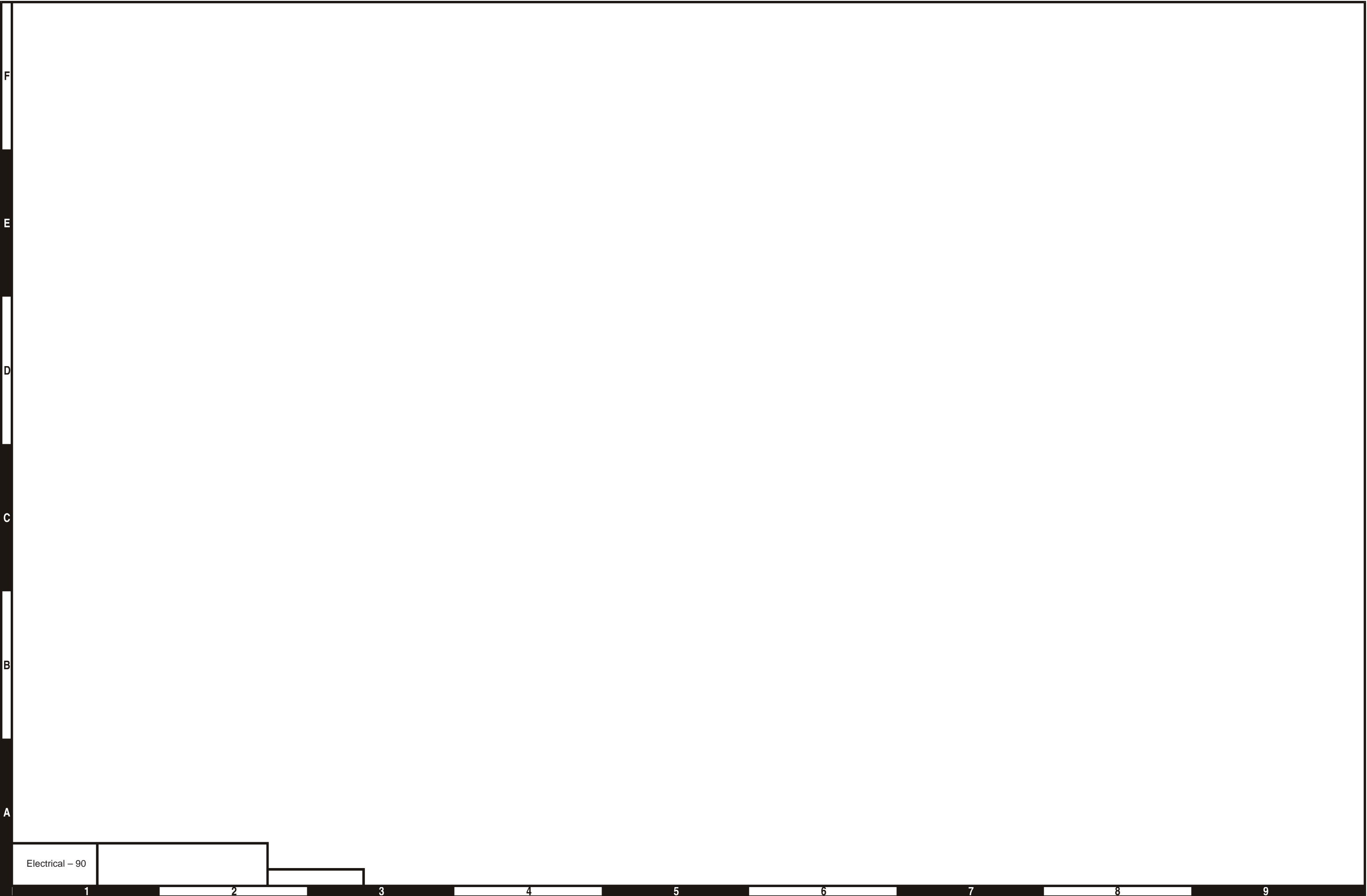

F

E

D

C

B

A



Electrical - 90

1

2

3

4

5

6

7

8

9

## Wiring Box Panel – Cummins, Deutz and CE

Item	Part No.	Qty.	Description
1	0180796	1	PANEL, DRILLED
2	3044712	1	TERMINAL STRIP (12) #10 STUD
3	3040433	3	TERMINAL STRIP (12) .187 TAB
4	0181552	1	DECAL, POWER
5	0181553	1	DECAL, TERMINAL STRIP
6	0181107	1	DECAL, CONTROL #1
7	0181106	1	DECAL, CONTROL #2
8	3040469	4	RELAY, BOSCH
9	3040287	1	RELAY, MIDTEX
10	0150488	1	DIODE HOLDER
11	5560038	22	NUT #10-32 ESNA
12	974239	4	SCREW RHD #6-32 .50
13	986159	4	WASHER FLAT #6
14	974689	1	SCREW RHD #10-24 .75
15	974726	1	SCREW RHD #10-24 1.25
16	5560004	7	NUT LKG #10-24
17	5560609	10	SCREW TRHD #10-24 .50
18	5560365	4	WASHER LOCK #10 MDM
19	5560664	10	WASHER LOCK #6 MDM
20	0181554	1	DECAL, DIODE
21	0073631	3	DIODE STAND OFF
22	0070681	1	JUMPER WIRE
23	0070711	1	JUMPER WIRE
24	0071812	2	JUMPER WIRE
25	987359	1	WASHER STAR TOOTH #10
26	0070682	1	DIODE WIRE
28	0140317	2	DIODE WIRE
29	0151205	1	JUMPER WIRE
30	0081560	1	JUMPER WIRE
31	0070724	1	JUMPER WIRE
32	0181110	3	DIODE WIRE
33	0181031	2	JUMPER WIRE
34	0081559	1	JUMPER WIRE
35	0081515	1	JUMPER WIRE
36	0181030	1	DIODE WIRE
37	0181136	2	JUMPER WIRE
38	0181111	2	JUMPER WIRE
39	0112164	1	DIODE WIRE
40	0070713	2	JUMPER WIRE
41	0140323	2	JUMPER WIRE
42	0140332	2	JUMPER WIRE
44	974279	6	SCREW RHD #6-32 .75
45	0090621	1	JUMPER WIRE
46	0110471	1	DIODE WIRE
47	0170335	1	DIODE WIRE
48	0181113	1	JUMPER WIRE
49	0073253	1	WIRE R101 R101 11 DIO SP
50	5560034	1	NUT HEXHD #10-24
51	0073252	1	WIRE 18 R101 R101 28 DIO

## Wiring Box Panel – Cummins, Deutz and CE



F

E

D

C

B

A

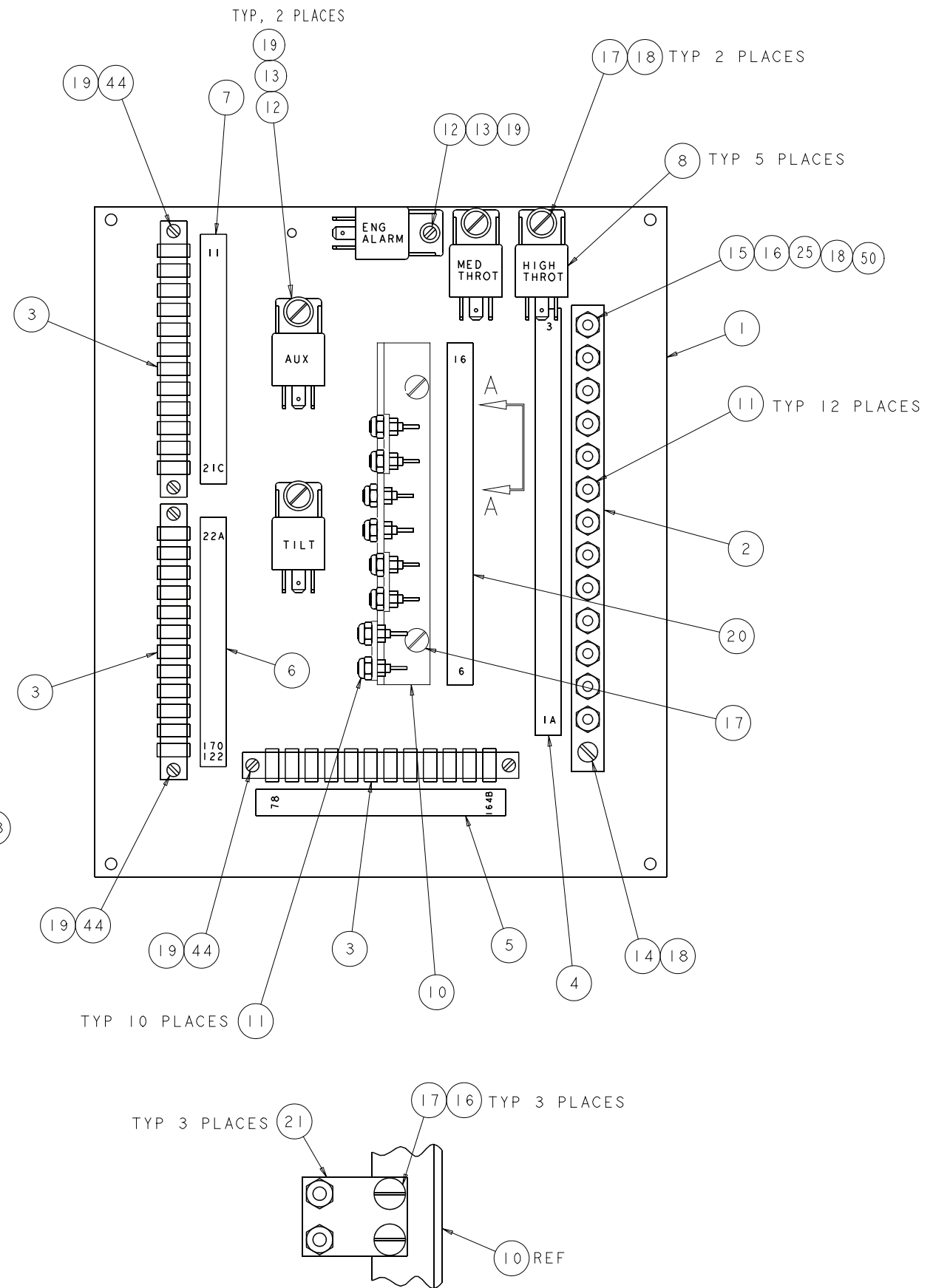
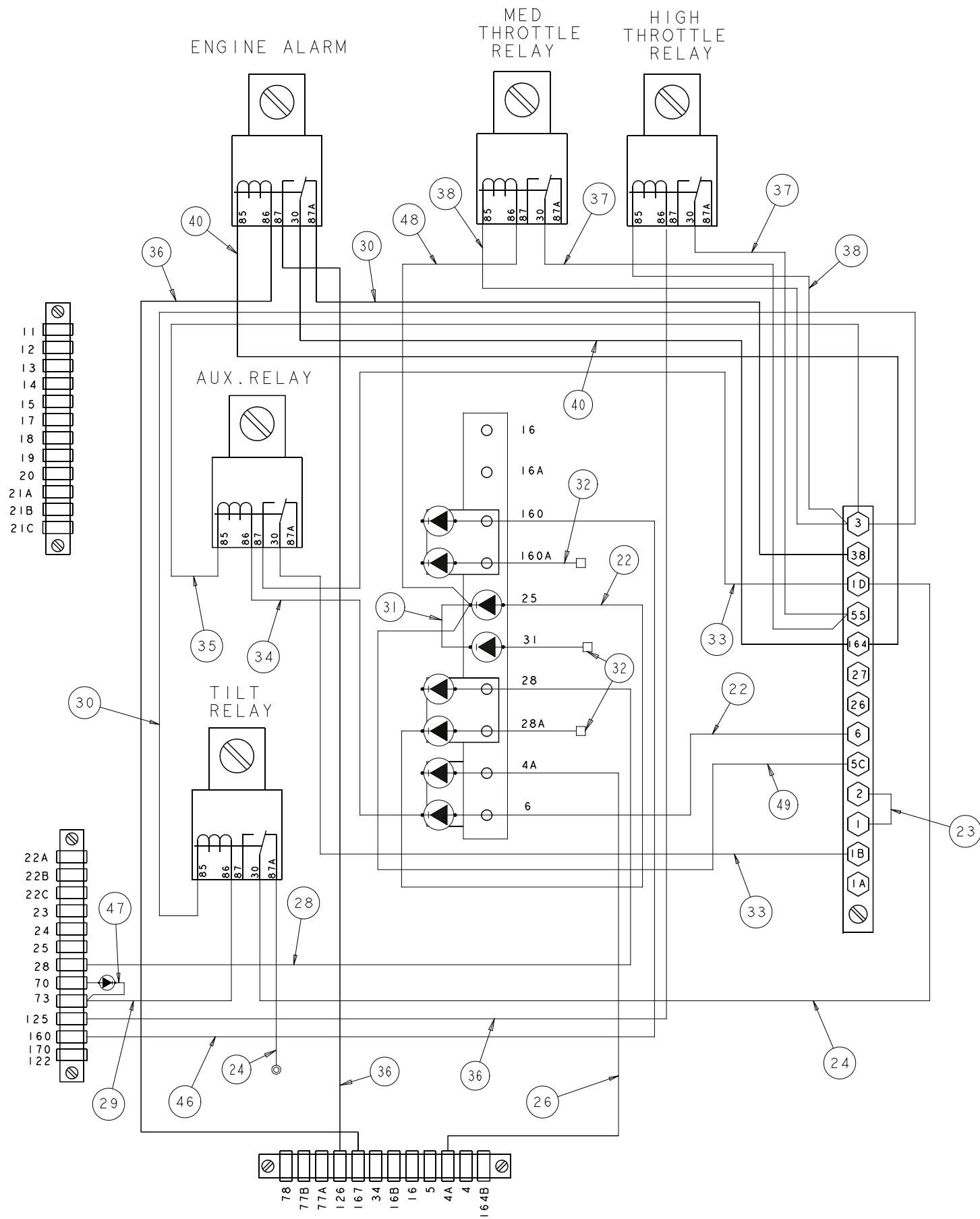

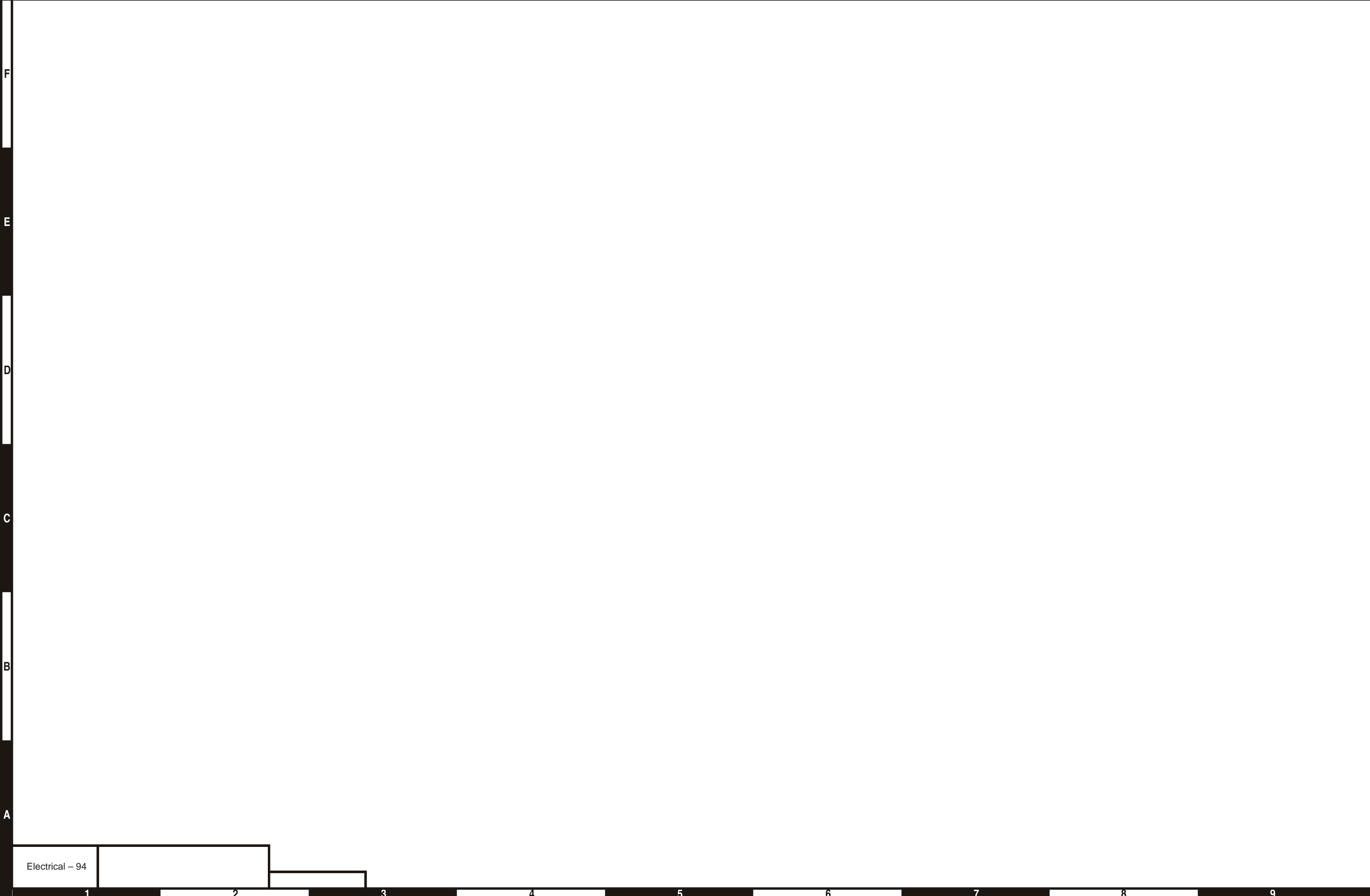

F

E

D

C

B

A

Electrical - 94

1

2

3

4

5

6

7

8

9

## Wiring Box Panel – GM

Item	Part No.	Qty.	Description
1	0180796	1	PANEL, DRILLED
2	3044712	1	TERMINAL STRIP (12) #10 STUD
3	3040433	3	TERMINAL STRIP (12) .187 TAB
4	0181552	1	DECAL, POWER
5	0181553	1	DECAL, TERMINAL STRIP
6	0181107	1	DECAL, CONTROL #1
7	0181106	1	DECAL, CONTROL #2
8	3040469	5	RELAY, BOSCH
10	0150488	1	DIODE HOLDER
11	5560038	22	NUT #10-32 ESNA
12	974239	4	SCREW RHD #6-32 .50
13	986159	4	WASHER FLAT #6
14	974689	1	SCREW RHD #10-24 .75
15	974726	1	SCREW RHD #10-24 1.25
16	5560004	7	NUT LKG #10-24
17	5560609	10	SCREW TRHD #10-24 .50
18	5560365	4	WASHER LOCK #10 MDM
19	5560664	10	WASHER LOCK #6 MDM
20	0181554	1	DECAL, DIODE
21	0073631	3	DIODE STAND OFF
22	0070681	2	JUMPER WIRE
23	0070711	1	JUMPER WIRE
24	0071812	2	JUMPER WIRE
25	987359	1	WASHER STAR TOOTH #10
26	0070682	1	DIODE WIRE
28	0140317	1	DIODE WIRE
29	0151205	1	JUMPER WIRE
30	0081560	2	JUMPER WIRE
31	0070724	1	JUMPER WIRE
32	0181110	3	DIODE WIRE
33	0181031	2	JUMPER WIRE
34	0081559	1	JUMPER WIRE
35	0081515	1	JUMPER WIRE
36	0181030	3	DIODE WIRE
37	0181136	2	JUMPER WIRE
38	0181111	2	JUMPER WIRE
40	0070713	2	JUMPER WIRE
44	974279	6	SCREW RHD #6-32 .75
46	0110471	1	DIODE WIRE
47	0170335	1	DIODE WIRE
48	0181113	1	JUMPER WIRE
49	0073253	1	WIRE R101 R101 11 DIO SP
50	5560034	1	NUT HEXHD #10-24

## Wiring Box Panel – GM





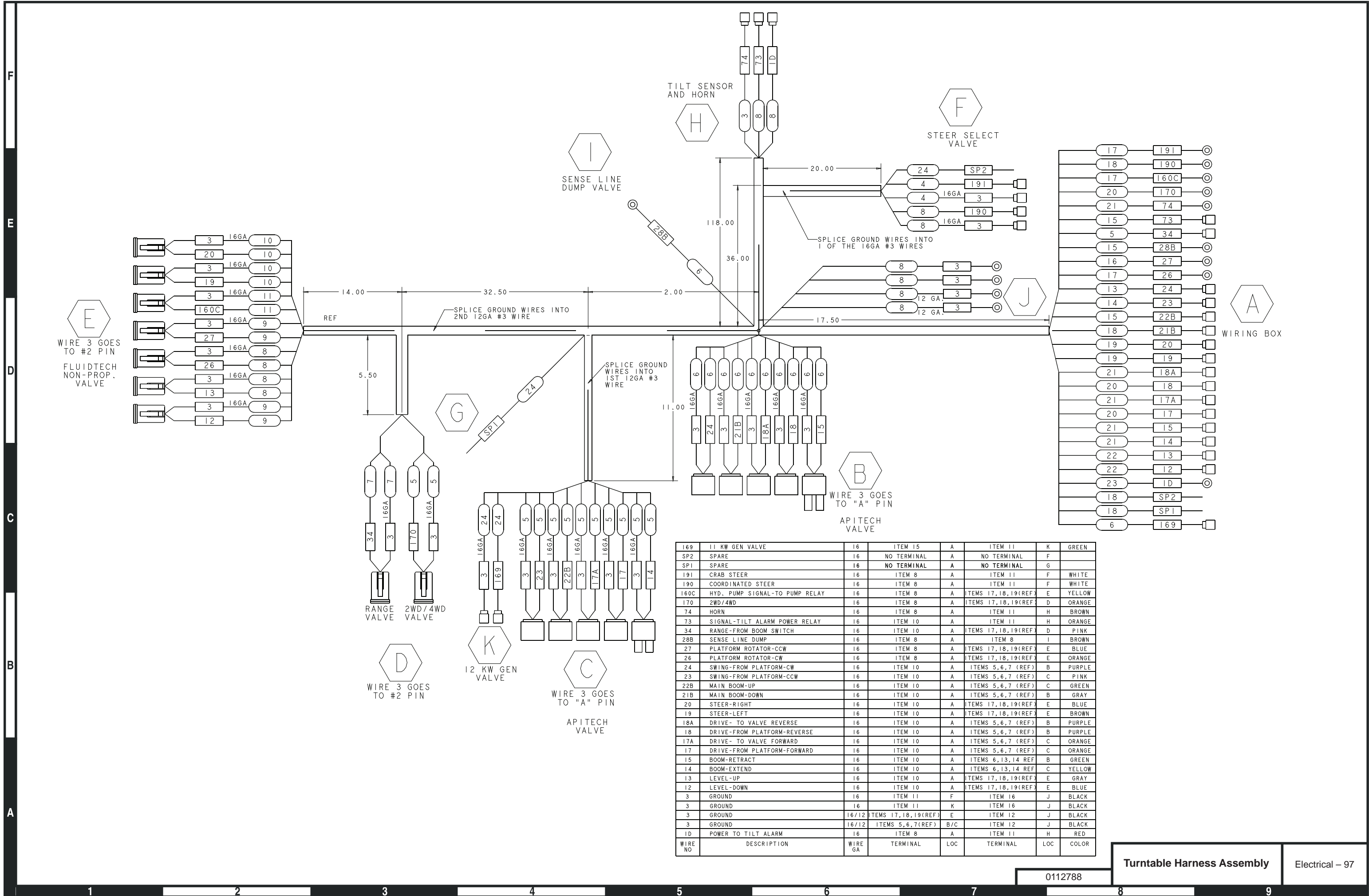

169	11 KW GEN VALVE	16	ITEM 15	A	ITEM 11	K	GREEN
SP2	SPARE	16	NO TERMINAL	A	NO TERMINAL	F	
SP1	SPARE	16	NO TERMINAL	A	NO TERMINAL	G	
191	CRAB STEER	16	ITEM 8	A	ITEM 11	F	WHITE
190	COORDINATED STEER	16	ITEM 8	A	ITEM 11	F	WHITE
160C	HYD. PUMP SIGNAL-TO PUMP RELAY	16	ITEM 8	A	ITEMS 17, 18, 19(REF)	E	YELLOW
170	2WD/4WD	16	ITEM 8	A	ITEMS 17, 18, 19(REF)	D	ORANGE
74	HORN	16	ITEM 8	A	ITEM 11	H	BROWN
73	SIGNAL-TILT ALARM POWER RELAY	16	ITEM 10	A	ITEM 11	H	ORANGE
34	RANGE-FROM BOOM SWITCH	16	ITEM 10	A	ITEMS 17, 18, 19(REF)	D	PINK
28B	SENSE LINE DUMP	16	ITEM 8	A	ITEM 8	I	BROWN
27	PLATFORM ROTATOR-CCW	16	ITEM 8	A	ITEMS 17, 18, 19(REF)	E	BLUE
26	PLATFORM ROTATOR-CW	16	ITEM 8	A	ITEMS 17, 18, 19(REF)	E	ORANGE
24	SWING-FROM PLATFORM-CW	16	ITEM 10	A	ITEMS 5, 6, 7 (REF)	B	PURPLE
23	SWING-FROM PLATFORM-CCW	16	ITEM 10	A	ITEMS 5, 6, 7 (REF)	C	PINK
22B	MAIN BOOM-UP	16	ITEM 10	A	ITEMS 5, 6, 7 (REF)	C	GREEN
21B	MAIN BOOM-DOWN	16	ITEM 10	A	ITEMS 5, 6, 7 (REF)	B	GRAY
20	STEER-RIGHT	16	ITEM 10	A	ITEMS 17, 18, 19(REF)	E	BLUE
19	STEER-LEFT	16	ITEM 10	A	ITEMS 17, 18, 19(REF)	E	BROWN
18A	DRIVE- TO VALVE REVERSE	16	ITEM 10	A	ITEMS 5, 6, 7 (REF)	B	PURPLE
18	DRIVE-FROM PLATFORM-REVERSE	16	ITEM 10	A	ITEMS 5, 6, 7 (REF)	B	PURPLE
17A	DRIVE- TO VALVE FORWARD	16	ITEM 10	A	ITEMS 5, 6, 7 (REF)	C	ORANGE
17	DRIVE-FROM PLATFORM-FORWARD	16	ITEM 10	A	ITEMS 5, 6, 7 (REF)	C	ORANGE
15	BOOM-RETRACT	16	ITEM 10	A	ITEMS 6, 13, 14 REF	B	GREEN
14	BOOM-EXTEND	16	ITEM 10	A	ITEMS 6, 13, 14 REF	C	YELLOW
13	LEVEL-UP	16	ITEM 10	A	ITEMS 17, 18, 19(REF)	E	GRAY
12	LEVEL-DOWN	16	ITEM 10	A	ITEMS 17, 18, 19(REF)	E	BLUE
3	GROUND	16	ITEM 11	F	ITEM 16	J	BLACK
3	GROUND	16	ITEM 11	K	ITEM 16	J	BLACK
3	GROUND	16/12	ITEMS 17, 18, 19(REF)	E	ITEM 12	J	BLACK
3	GROUND	16/12	ITEMS 5, 6, 7(REF)	B/C	ITEM 12	J	BLACK
1D	POWER TO TILT ALARM	16	ITEM 8	A	ITEM 11	H	RED
WIRE NO	DESCRIPTION	WIRE GA	TERMINAL	LOC	TERMINAL	LOC	COLOR

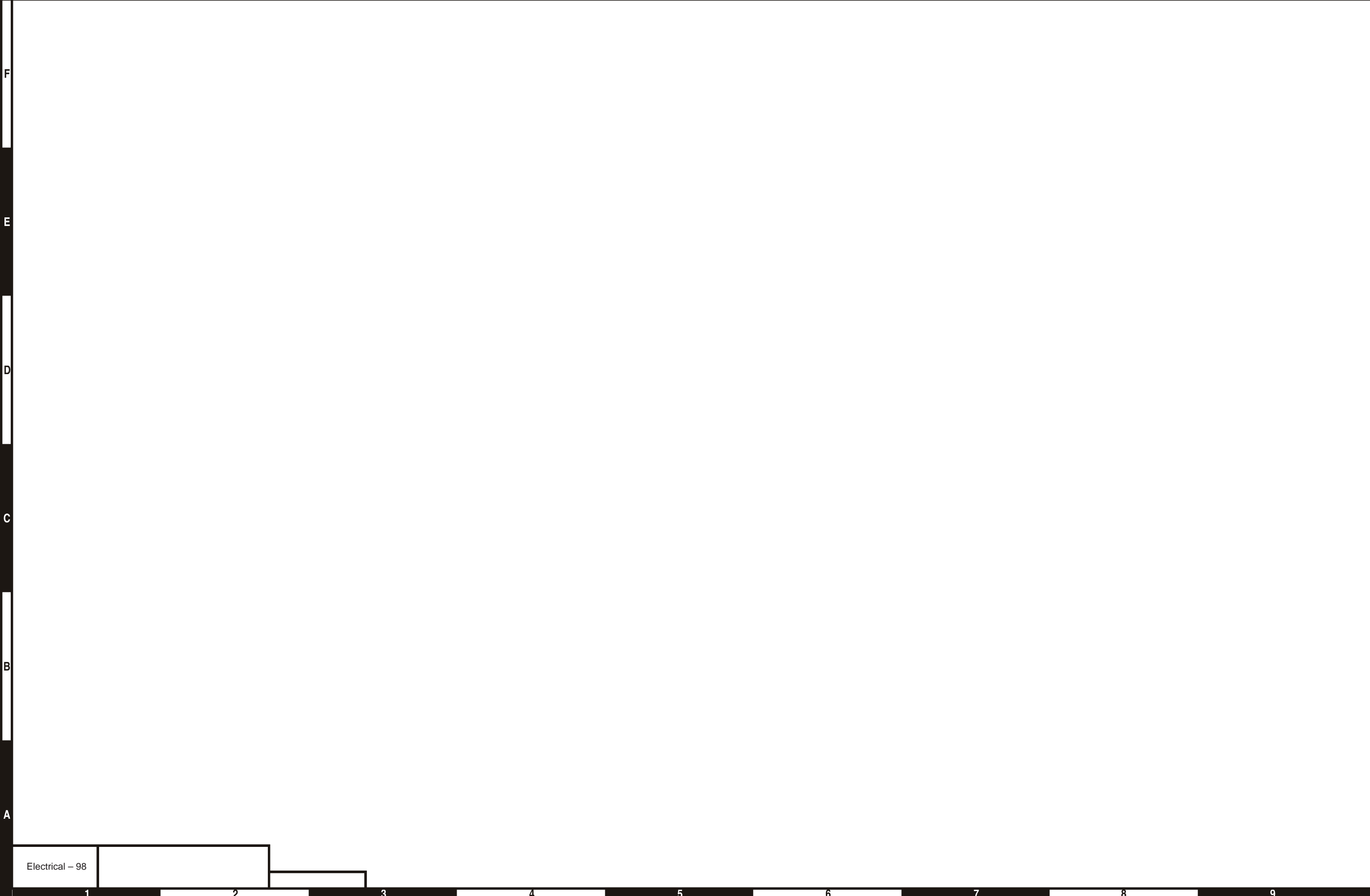

F

E

D

C

B

A



Electrical - 98

1

2

3

4

5

6

7

8

9

## Turntable Harness Assembly

Item	Part No.	Qty.	Description
1	3011601	192 FT	16 GA. SINGLE CONDUCTOR WIRE
2	3011201	1 ft	12 GA. SINGLE CONDUCTOR WIRE
3	3090008	5.5 FT	FLEXGARD TUBE .625 ID
4	3090006	13 FT	FLEXGARD TUBE .350 ID
5	3040498	8	WEATHERPAK SHROUD BODY
6	3040499	19	WEATHERPAK CABLE SEAL
7	3040500	16	WEATHERPAK TERMINAL
8	3044161	11	TERMINAL #10 STUD 16/14 WIRE
10	3046697	16	TERMINAL FEM1881 16/14
11	3040083	9	TERMINAL FEM250F1 16/14
12	3044855	2	TERMINAL 1/4 STUD 12/10 WIRE
13		2	WEATHERPAK TOWER BODY
14		4	WEATHERPAK TERMINAL (SOCKET)
15	3040082	1	TERMINAL MALE250F1 16/14
16	3044162	2	TERMINAL R2501 16/14
17	3049803	9	CONNECTOR 2-PIN DEUTSCH PLUG
18	3040342	18	SOCKET CONTACT SIZE 16/18 GA
19	3049807	9	LOCK WEDGE 2-PIN DEUTSCH PLUG

## Turntable Harness Assembly



F  
E  
D  
C  
B  
A

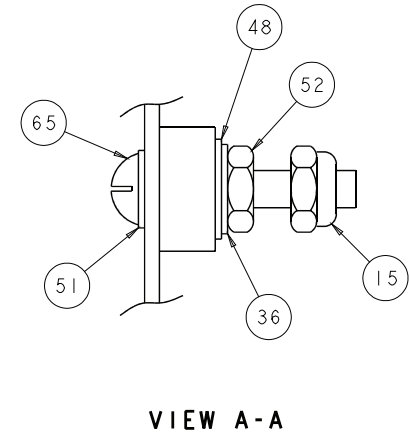
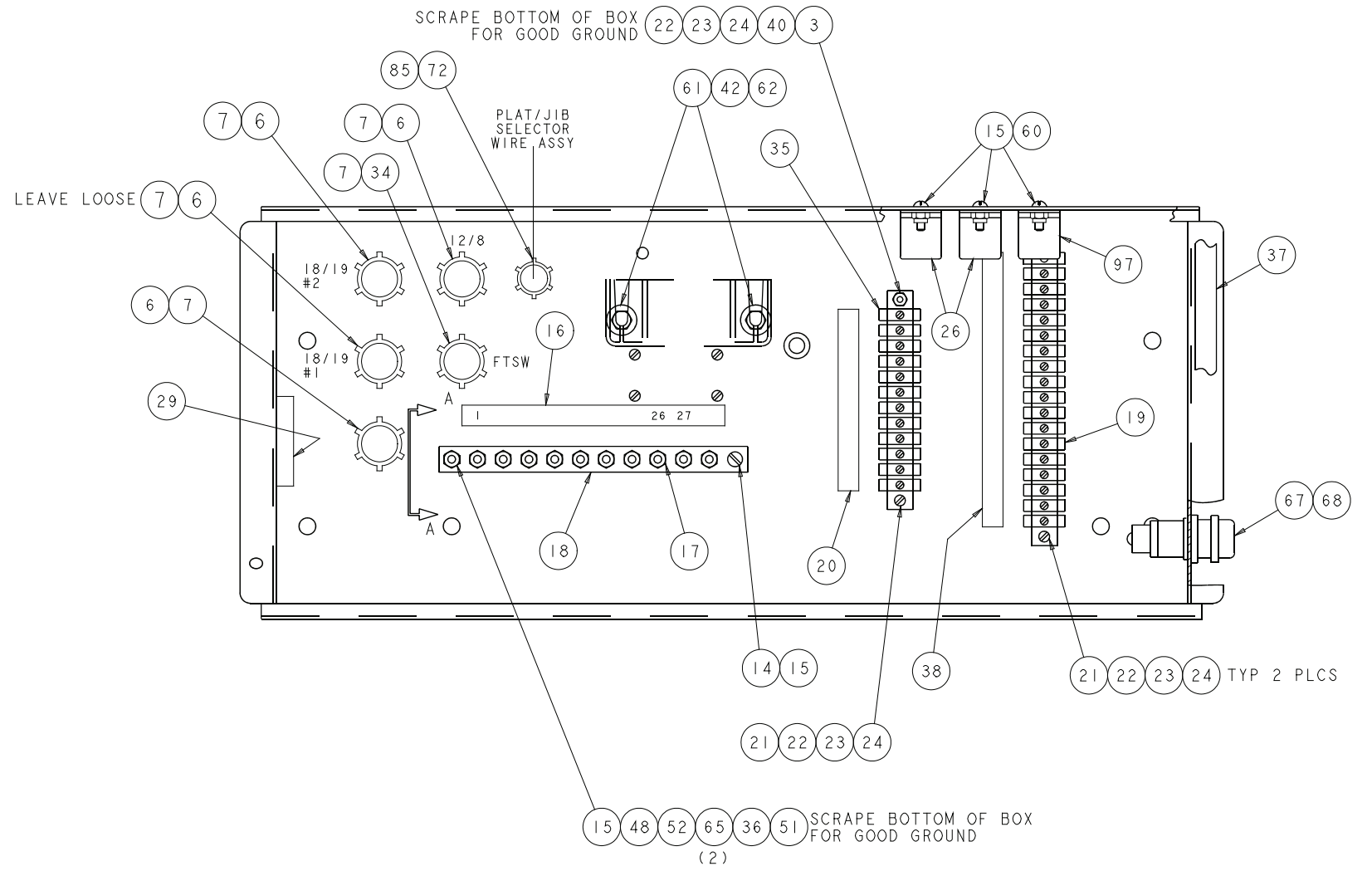
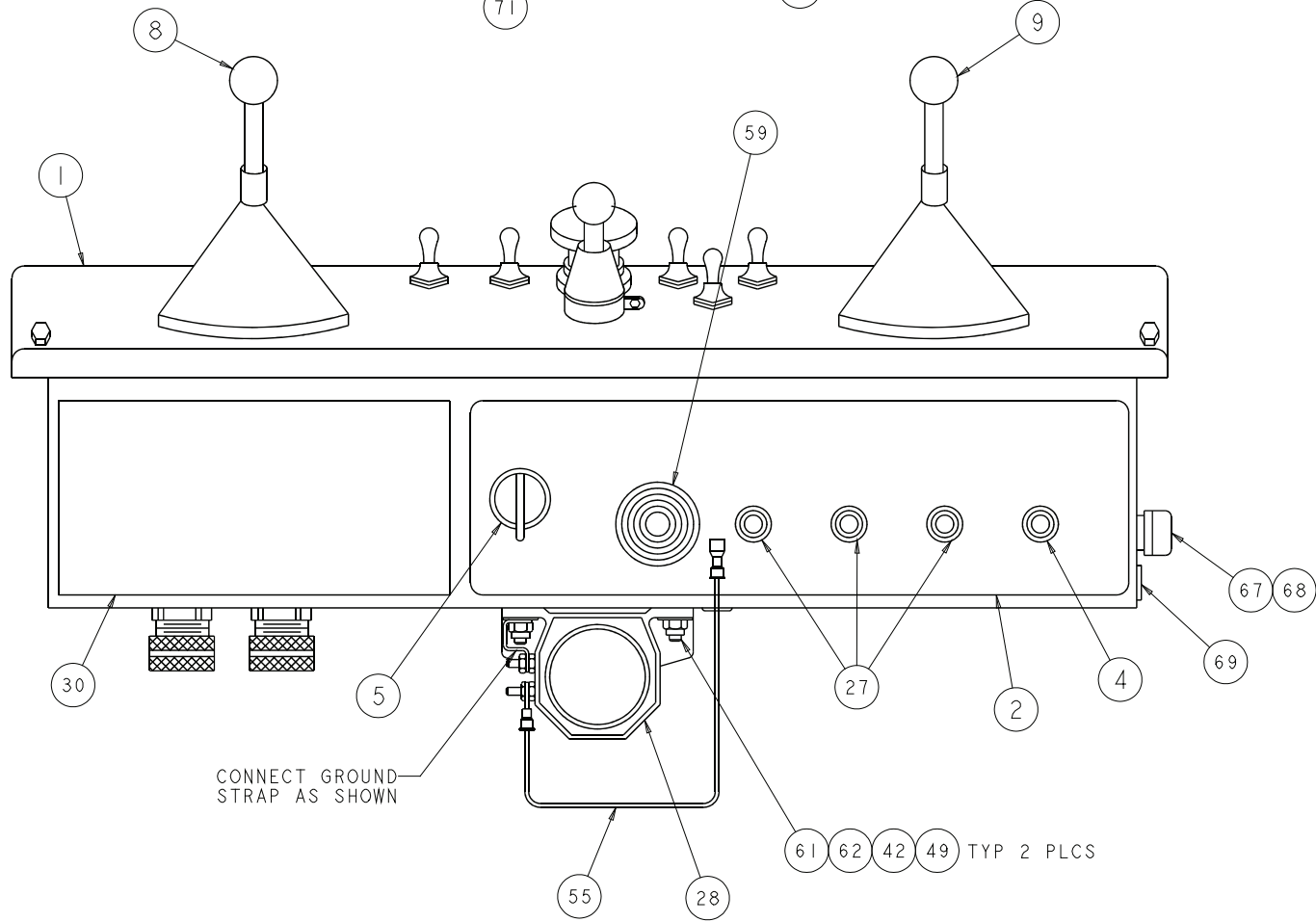
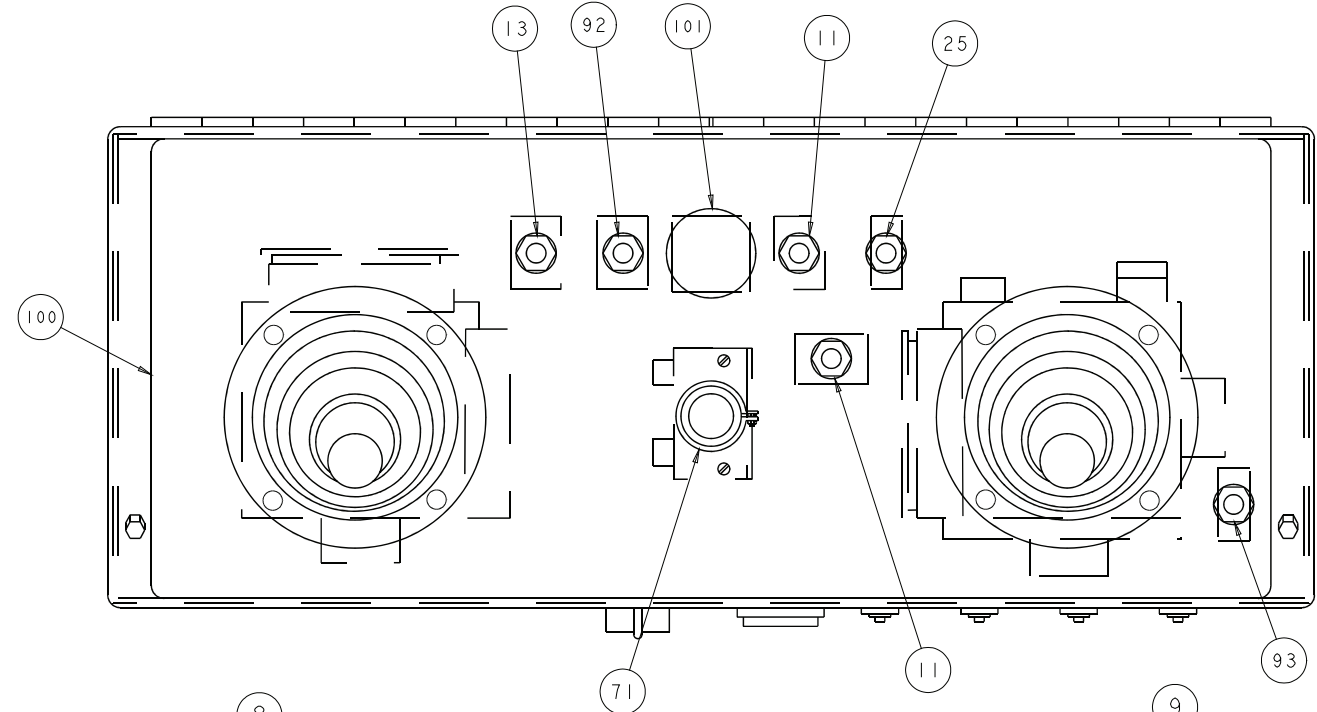

F  
E  
D  
C  
B  
A

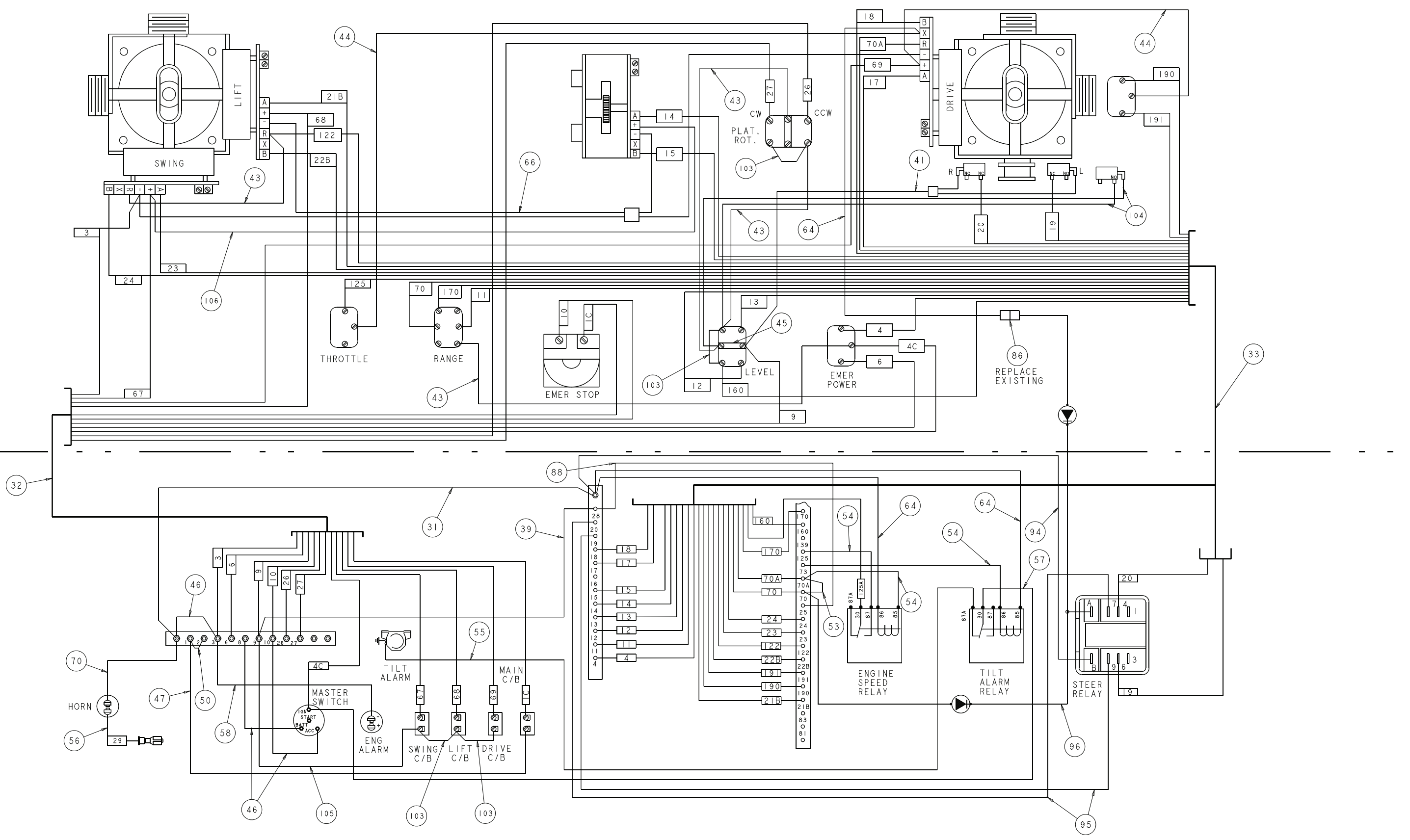

## Upper Control Panel – TB80

Item	Part No.	Qty.	Description
1	0111928	1	WELDMENT PLATFORM CONTROL BOX
2	0180846	1	PLACARD PLATFORM CONTROL BOX FRONT
3	5560663	1	WASHER 6 STAR TOOTH
4	3040068	1	CIRCUIT BREAKER 20 AMP
5	3020090	1	SWITCH ANTI-RESTART IGNITION
6	3040116	4	CONNECTOR .75 .500-.625
7	3040110	5	NUT LKG .750 HUB
8	304049328	1	DUAL AXIS CONTROLLER
9	304049228	1	DUAL AXIS CONTROLLER
11	3020018	2	SWITCH TOGGLE DPDT ON/OFF/ON
13	3020013	1	SWITCH TOGGLE SPST ON OFF SEALED
14	5563025	1	SCREW THRD 10-24 .750
15	5560034	6	NUT LKG 10-24
16	0180886	1	DECAL TERMINAL STRIP HORIZ 10 TERM
17	5560038	10	NUT LKG 10-32
18	3044710	1	TERMINAL STRIP (10) #10 STUD
19	3040057	1	TERMINAL STRIP 18 CIRCUIT
20	0180887	1	DECAL TERMINAL STRIP HORIZ 13 TERM
21	974279	3	SCREW RHD 6-32 .750
22	986159	4	WASHER FLAT 6 WRT
23	5560664	4	WASHER LOCK 6
24	984009	4	NUT HEX 6-32
25	3020080	1	SWITCH TOGGLE SPDT (M/NONE/ON) SEALED
26	3040469	2	RELAY SPDT 12V 30 AMP
27	3040535	3	CIRCUIT BREAKER 3 AMP
28	480652	1	ALARM 97DBA DUAL TONE 12/24V
29	0070967	1	CORROSION INHIBITOR STICK-BACK
30	0072530	1	DECAL DANGER ELECTRICAL HAZARD
31	0151910	1	WIRE 16 R6 R10 14
32	0180850	1	PLATFORM CONTROL BOX WIRING HARNESS
33	0082007	1	WIRE ASSEMBLY CONT
34	3040295	1	CONNECTOR .75 .625-.750
35	3040433	1	TERMINAL STRIP (12)
36	5560365	1	WASHER LOCK 10
37	7190001	72 IN	GASKET
38	0180888	1	DECAL TERMINAL STRIP HORIZ 16 TERM
39	0070713	1	WIRE 18 R101 FEM1871 IO
40	974269	1	SCREW RHD 6-32 1.00
41	0072388	1	WIRE 18
42	986019	2	WASHER FLAT .250 WRT
43	0070746	4	WIRE 16 R61 R61 9
44	0070753	1	WIRE 16 R61 R61 12
45	0060373	1	JUMPER SW TERM STRAP
46	0070712	3	WIRE 12 R101 R101 5
47	0181029	1	WIRE 12 R6 R10 19.5
48	986009	1	WASHER FLAT 10
49	5560004	2	NUT HEX .250-20
50	0070711	1	WIRE 12 R101 R101 3
51	987359	1	WASHER 10 STAR TOOTH
52	5560034	1	NUT HEX 10-24
53	0110468	1	WIRE 16 FEM1871 FEM1871 4
54	0090622	3	WIRE 18 FEM1871 FEM2501 9
55	0181103	1	WIRE 16 R10 FEM250FI 18
56	0071557	1	WIRE 18 R81 MALE250FI 7
57	0071812	1	WIRE 16 R10 FEM250FI 18
58	0151816	1	WIRE 16 R101 R101 7.5
59	3040411	1	ALARM MINI SIREN 6-28VDC
60	5560609	4	SCREW THRD 10-24 .500
61	970029	2	BOLT .25-20 .750 GR5

## Upper Control Panel – TB80

## Upper Control Panel – TB80

Item	Part No.	Qty.	Description
62	5560004	2	NUT LKG .250-20
63	5569711	1	GROMMET .438ID .938OD .125
64	0073295	3	WIRE 16 R61 FEM250FI 8
65	5563025	2	SCREW THRD 10-24 1.00
66	0110598	1	WIRE 18
67	3026027	1	SWITCH PUSH BUTTON
68	7140092	1	STATOSEAL KIT PARTNER
69	0071269	1	DECAL HORN
70	0070733	1	WIRE 16 R81 R101 24
71	3040525	1	CONTROLLER SINGLE AXIS 63HZ
72	0181030	1	WIRE 16 FEM1881 FEM250FI 15
85	3040070	1	LOCKNUT .50 HUB
86	3040082	2	TERMINAL MALE 250F1 16/14
88	0071840	1	WIRE 16 FEM1881 FEM1881 11
92	3020017	1	SWITCH TOGGLE DPDT (ON/OFF/ON) SEALED
93	239926	1	SWITCH TOGGLE SPDT (ON/OFF/ON) SEALED
94	0071546	1	WIRE 18 R61 FEM1881 8
95	0071511	2	WIRE 18 FEM1881 FEM1881 11
96	0180889	1	WIRE 18 DIO
97	3040214	1	RELAY DPDT 12V 10AMP
100	0112551	1	PLACARD PLATFORM CONTROL BOX TOP
101	3020020	1	SWITCH EMERGENCY STOP PUSH/PULL
103	0070747	4	WIRE 16 R61 R61 3
104	0181028	1	WIRE 16 R6 FEM187 10.5
105	0240483	1	WIRE 16 R61 R101 8
106	0070758	1	WIRE 16 R61 R101 20
107	0180889	1	WIRE 18 DIO
108	0073295	1	WIRE 16 R61 FEM250FI 8
109	0071511	2	WIRE 18 FEM1881 FEM1881 11

## Upper Control Panel – TB80



F

E

D

C

B

A

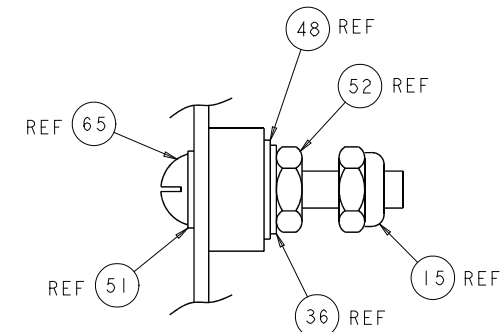
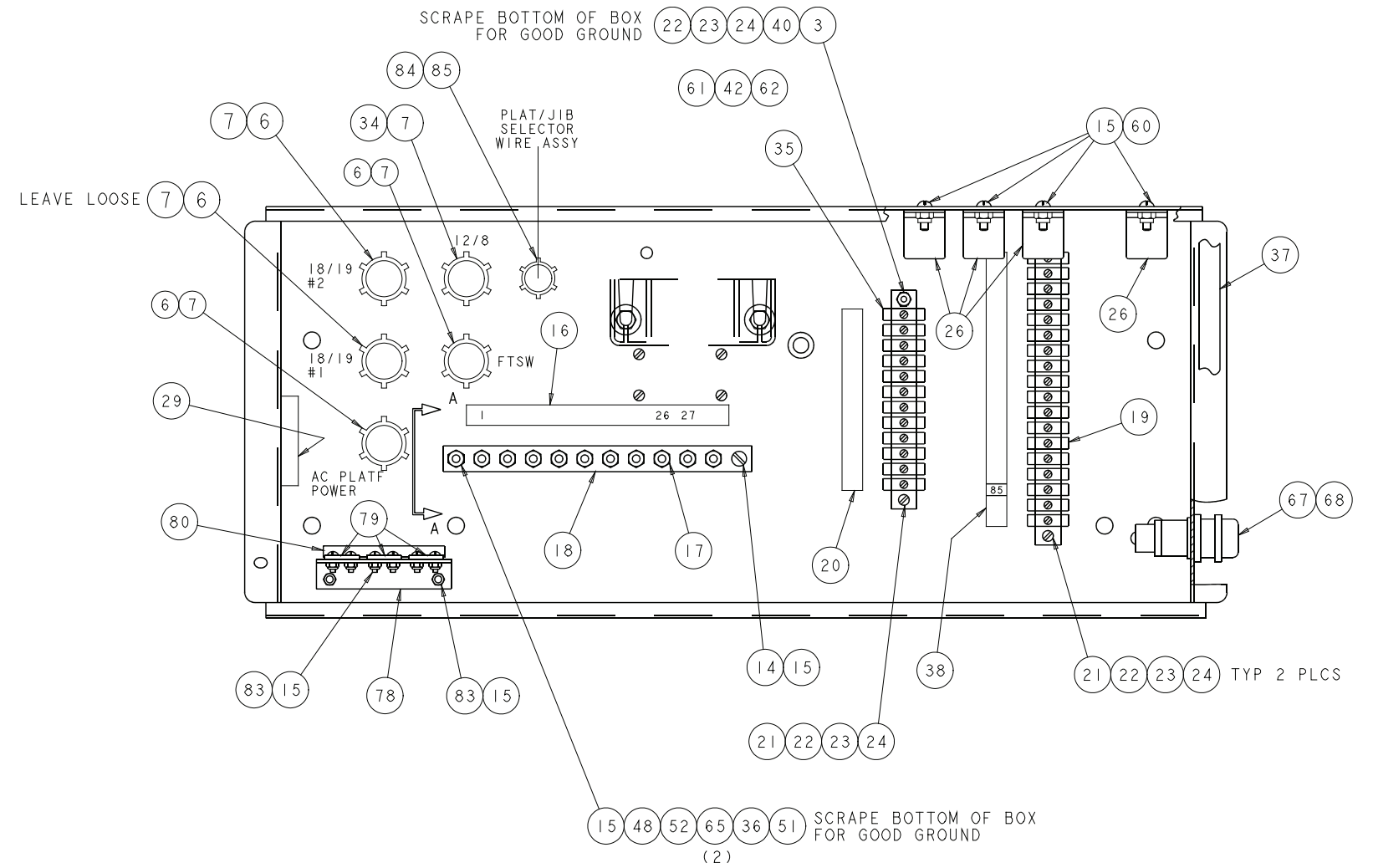
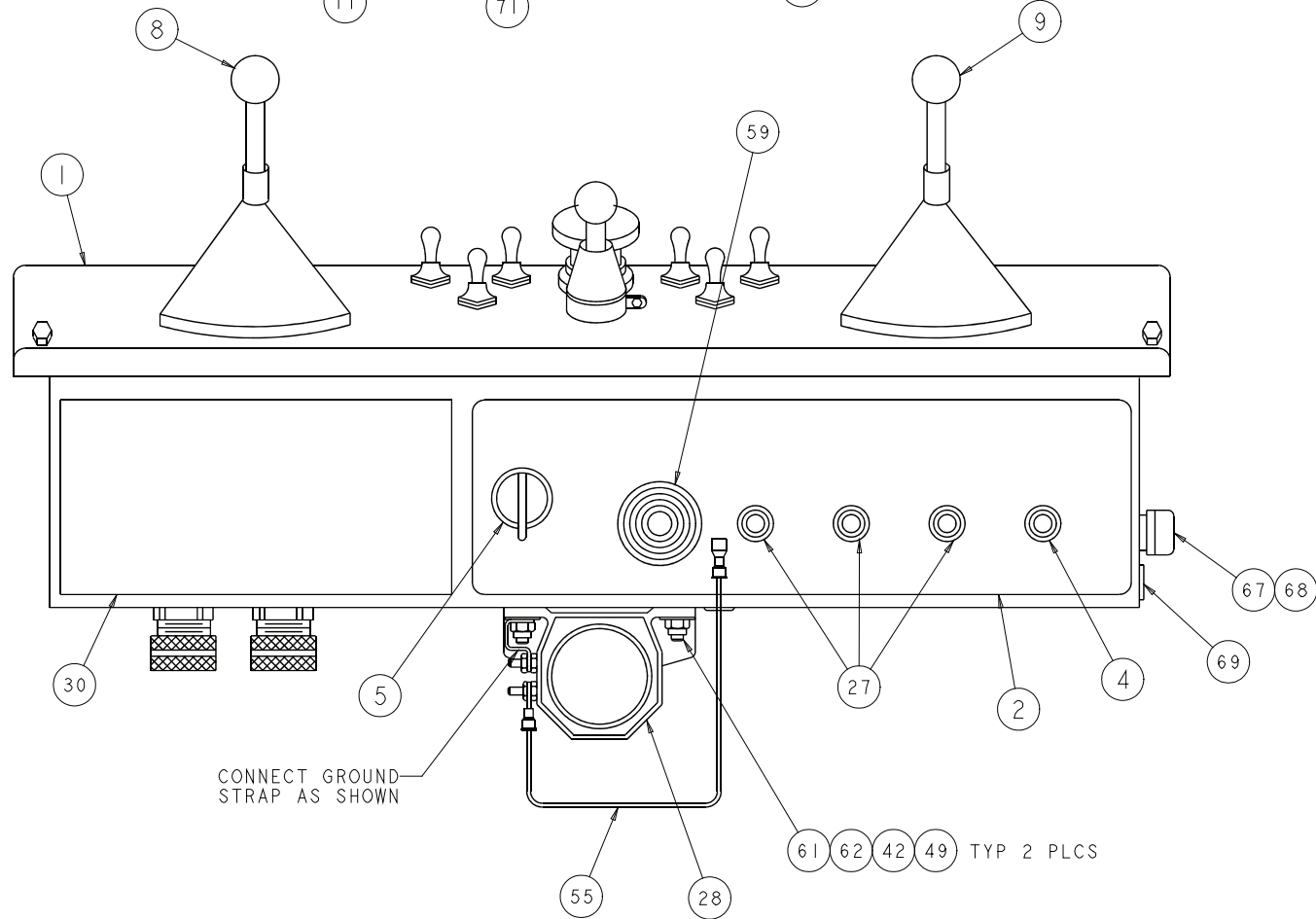
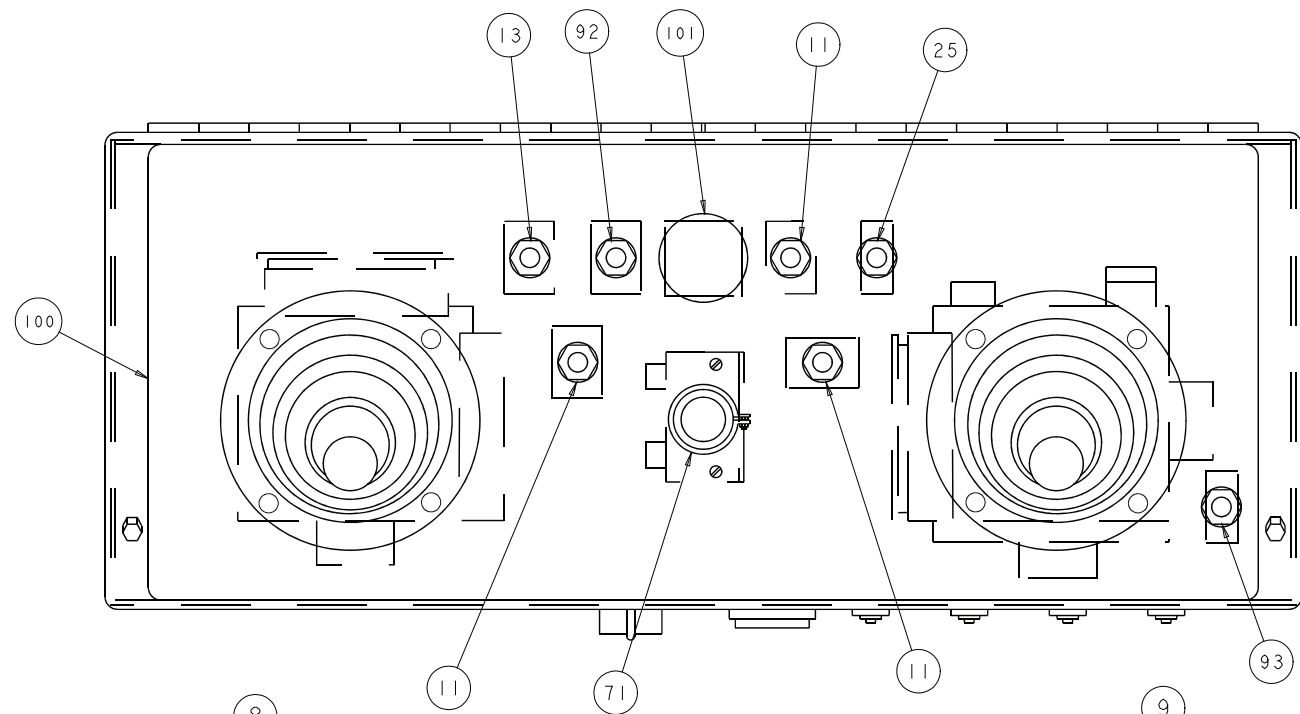

VIEW A-A

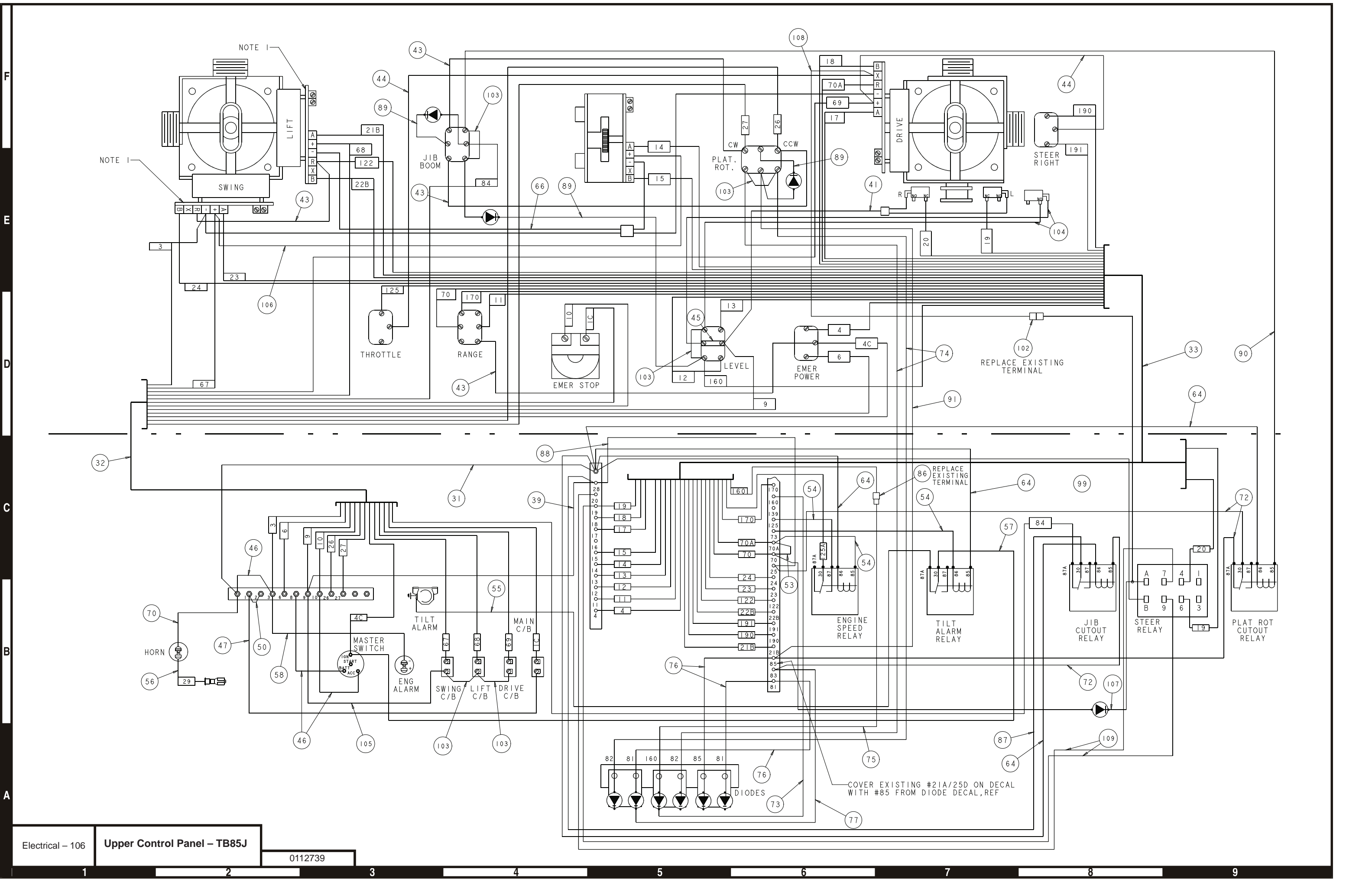

## Upper Control Panel – TB85J

Item	Part No.	Qty.	Description
1	0111928	1	WELDMENT PLATFORM CONTROL BOX
2	0180846	1	PLACARD PLATFORM CONTROL BOX FRONT
3	5560663	1	WASHER 6 STAR TOOTH
4	3040068	1	CIRCUIT BREAKER 20 AMP
5	3020090	1	SWITCH ANTI-RESTART IGNITION
6	3040116	4	CONNECTOR .75 .500-.625
7	3040110	5	NUT LKG .750 HUB
8	304049328	1	DUAL AXIS CONTROLLER
9	304049228	1	DUAL AXIS CONTROLLER
11	3020018	3	SWITCH TOGGLE DPDT ON/OFF/ON
13	3020013	1	SWITCH TOGGLE SPST ON OFF SEALED
14	5563025	1	SCREW THRD 10-24 .750
15	5560034	12	NUT LKG 10-24
16	0180886	1	DECAL TERMINAL STRIP HORIZ 10 TERM
17	5560038	10	NUT LKG 10-32
18	3044710	1	TERMINAL STRIP (10) #10 STUD
19	3040057	1	TERMINAL STRIP 18 CIRCUIT
20	0180887	1	DECAL TERMINAL STRIP HORIZ 13 TERM
21	674279	3	SCREW RHD 6-32 .750
22	986159	4	WASHER FLAT 6 WRT
23	5560664	4	WASHER LOCK 6
24	984009	4	NUT HEX 6-32
25	3020080	1	SWITCH TOGGLE SPDT (M/NONE/ON) SEALED
26	3040469	4	RELAY SPDT 12V 30 AMP
27	3040535	3	CIRCUIT BREAKER 3 AMP
28	480652	1	ALARM 97DBA DUAL TONE 12/24V
29	0070967	1	CORROSION INHIBITOR STICK-BACK
30	0072530	1	DECAL DANGER ELECTRICAL HAZARD
31	0151910	1	WIRE 16 R6 R10 14
32	0180850	1	PLATFORM CONTROL BOX WIRING HARNESS
33	0082007	1	WIRE ASSEMBLY CONT
34	3040295	1	CONNECTOR .75 .625-.750
35	3040433	1	TERMINAL STRIP (12)
36	5560365	1	WASHER LOCK 10
37	7190001	72 IN	GASKET
38	0180888	1	DECAL TERMINAL STRIP HORIZ 16 TERM
39	0070713	1	WIRE 18 R101 FEM1871 IO
40	974269	1	SCREW RHD 6-32 1.00
41	0072388	1	WIRE 18
42	986019	2	WASHER FLAT .250 WRT
43	0070746	4	WIRE 16 R61 R61 9
44	0070753	2	WIRE 16 R61 R61 12
45	0060373	1	JUMPER SW TERM STRAP
46	0070712	3	WIRE 12 R101 R101 5
47	0181029	1	WIRE 12 R6 R10 19.5
48	986009	1	WASHER FLAT 10
49	5560004	2	NUT HEX .250-20
50	0070711	1	WIRE 12 R101 R101 3
51	987359	1	WASHER 10 STAR TOOTH
52	984049	1	NUT HEX 10-24
53	0110468	1	WIRE 16 FEM1871 FEM1871 4
54	0090622	3	WIRE 18 FEM1871 FEM2501 9
55	0181103	1	WIRE 16 R10 FEM250FI 18
56	0071557	1	WIRE 18 R81 MALE250FI 7
57	0071812	1	WIRE 16 R10 FEM250FI 18
58	0151816	1	WIRE 16 R101 R101 7.5
59	3040411	1	ALARM MINI SIREN 6-28VDC
60	5560609	4	SCREW THRD 10-24 .500

## Upper Control Panel – TB85J

## Upper Control Panel – TB85J

Item	Part No.	Qty.	Description
61	970029	2	BOLT .25-20 .750 GR5
62	5560004	2	NUT LKG .250-20
63	5569711	1	GROMMET .438ID .938OD .125
64	0073295	4	WIRE 16 R61 FEM250FI 8
65	5560673	2	SCREW THRD 10-24 1.00
66	0110598	1	WIRE 18
67	3026027	1	SWITCH PUSH BUTTON
68	7140092	1	STATOSEAL KIT PARTNER
69	0071269	1	DECAL HORN
70	0070733	1	WIRE 16 R81 R101 24
71	3040525	1	CONTROLLER SINGLE AXIS 63HZ
72	0181030	3	WIRE 16 FEM1881 FEM250FI 15
73	0071534	1	WIRE 10 R101 FEM1881 21
74	0172238	2	WIRE 16 R61 DIO 30
75	0172237	1	WIRE 16 FEM250FI DIO 16
76	0172236	3	WIRE 16 FEM1881 DIO 16
77	0073728	1	WIRE 16 R101 FEM1881 18
78	0172240	1	DIODE HOLDER
79	0073631	3	DIODE STAND OFF
80	0112797	1	DECAL, DIODES
83	5560609	4	SCREW #10-24 X .50 TRHD
84	3040300	1	CONN .50 .188-.313
85	3040070	1	LOCKNUT .50 HUB
86	3040082	1	TERMINAL MALE 250F1 16/14
87	0151205	1	WIRE 16 FEM1881 FEM250FI 7
88	0071840	1	WIRE 16 FEM1881 FEM1881 11
89	0111477	3	DIODE WIRE ASSY
90	0073884	1	WIRE 16 R61 FEM250FI 24
91	0071538	1	WIRE 18 R61 FEM1881 22
92	3020017	1	SWITCH TOGGLE DPDT (ON/OFF/ON) SEALED
93	239926	1	SWITCH TOGGLE SPDT (ON/OFF/ON) SEALED
99	0071546	1	WIRE 18 R61 FEM1881 8
100	0112551	1	PLACARD PLATFORM CONTROL BOX TOP
101	3020020	1	SWITCH EMERGENCY STOP PUSH/PULL
102	3040082	1	TERMINAL MALE 250FI 16/14
103	0070747	5	WIRE 16 R61 R61 3
104	0181028	1	WIRE 16 R6 FEM187 10.5
105	0240483	1	WIRE 16 R61 R101 8
106	0070758	1	WIRE 16 R61 R101 20
107	0180889	1	WIRE 18 DIO
108	0073295	1	WIRE 16 R61 FEM250FI 8
109	0071511	2	WIRE 18 FEM1881 FEM1881 11

## Upper Control Panel – TB85J

F

E

D

C

B

A

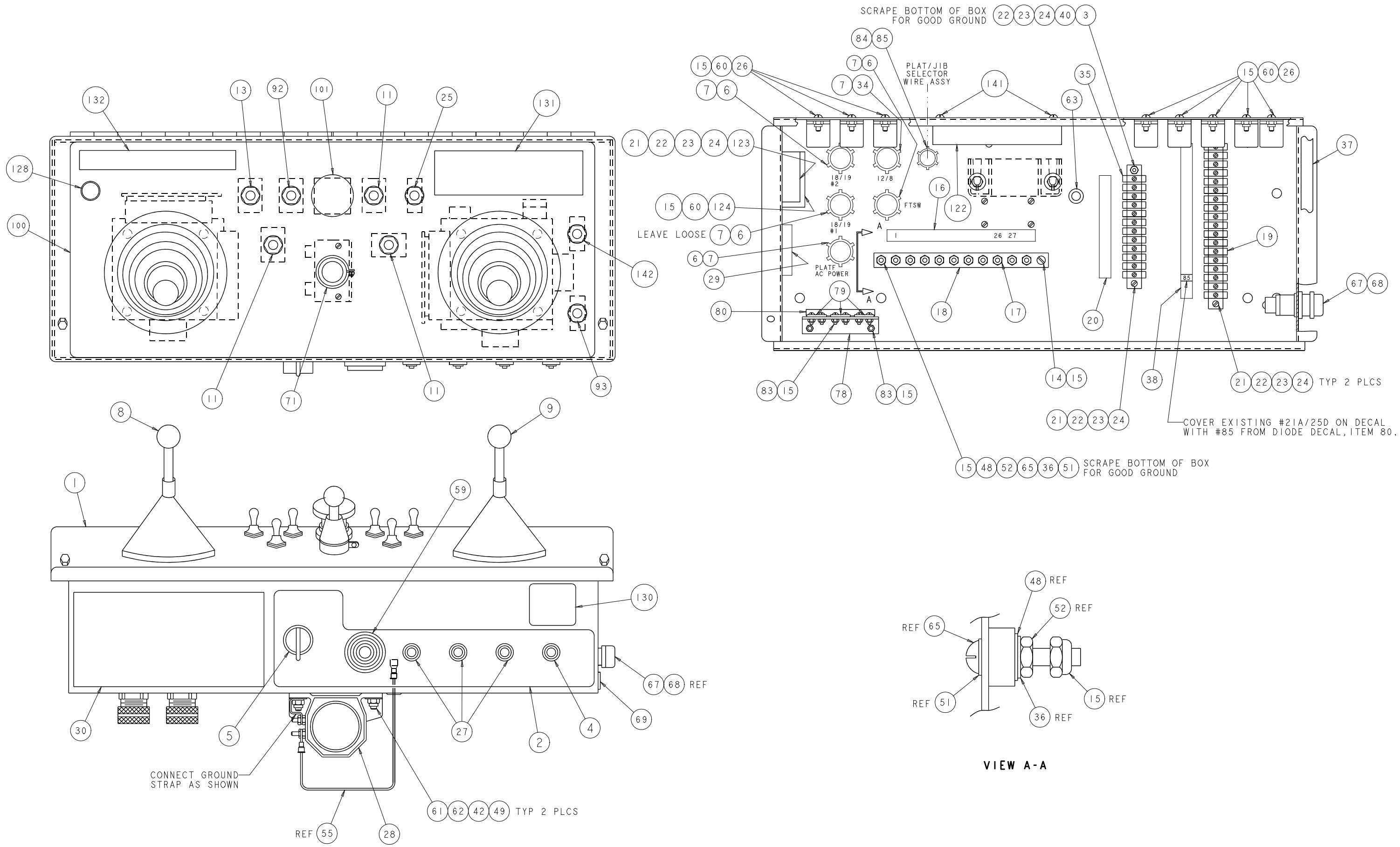

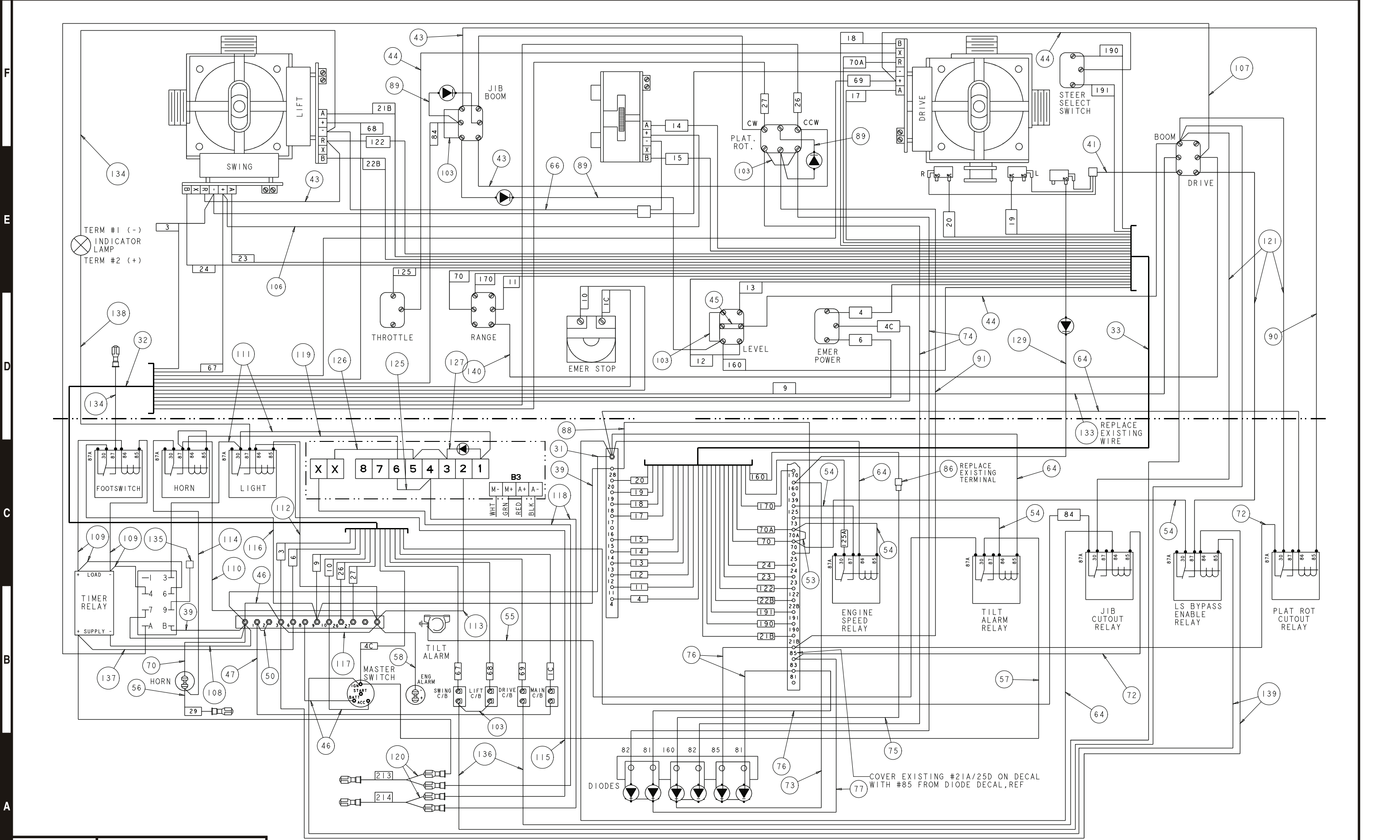

## Upper Control Panel – CE

Item	Part No.	Qty.	Description
1	0111928	1	WELDMENT PLATFORM CONTROL BOX
2	0180846	1	PLACARD PLATFORM CONTROL BOX FRONT
3	5560663	1	WASHER 6 STAR TOOTH
4	3040068	1	CIRCUIT BREAKER 20 AMP
5	3020090	1	SWITCH ANTI-RESTART IGNITION
6	3040116	4	CONNECTOR .75 .500-.625
7	3040110	5	NUT LKG .750 HUB
8	304049328	1	DUAL AXIS CONTROLLER
9	304049228	1	DUAL AXIS CONTROLLER
11	3020018	3	SWITCH TOGGLE DPDT ON/OFF/ON
13	3020013	1	SWITCH TOGGLE SPST ON OFF SEALED
14	5563025	1	SCREW THRD 10-24 .750
15	5560034	20	NUT LKG 10-24
16	0180886	1	DECAL TERMINAL STRIP HORIZ 10 TERM
17	5560038	10	NUT LKG 10-32
18	3044710	1	TERMINAL STRIP (10) #10 STUD
19	3040057	1	TERMINAL STRIP 18 CIRCUIT
20	0180887	1	DECAL TERMINAL STRIP HORIZ 13 TERM
21	674279	5	SCREW RHD 6-32 .750
22	986159	6	WASHER FLAT 6 WRT
23	5560664	6	WASHER LOCK 6
24	984009	6	NUT HEX 6-32
25	3020080	1	SWITCH TOGGLE SPDT (M/NONE/ON) SEALED
26	3040469	8	RELAY SPDT 12V 30 AMP
27	3040535	3	CIRCUIT BREAKER 3 AMP
28	480652	1	ALARM 97DBA DUAL TONE 12/24V
29	0070967	1	CORROSION INHIBITOR STICK-BACK
30	0072530	1	DECAL DANGER ELECTRICAL HAZARD
31	0151910	1	WIRE 16 R6 R10 14
32	0180850	1	PLATFORM CONTROL BOX WIRING HARNESS
33	0082007	1	WIRE ASSEMBLY CONT
34	3040295	1	CONNECTOR .75 .625-.750
35	3040433	1	TERMINAL STRIP (12)
36	5560365	1	WASHER LOCK 10
37	7190001	72 IN	GASKET
38	0180888	1	DECAL TERMINAL STRIP HORIZ 16 TERM
39	0070713	2	WIRE 18 R101 FEM1871 IO
40	974269	1	SCREW RHD 6-32 1.00
41	0181074	1	WIRE 18
42	986019	2	WASHER FLAT .250 WRT
43	0070746	3	WIRE 16 R61 R61 9
44	0070753	3	WIRE 16 R61 R61 12
45	0060373	1	JUMPER SW TERM STRAP
46	0070712	3	WIRE 12 R101 R101 5
47	0181029	1	WIRE 12 R6 R10 19.5
48	986009	1	WASHER FLAT 10
49	5560004	2	NUT HEX .250-20
50	0070711	1	WIRE 12 R101 R101 3
51	987359	1	WASHER 10 STAR TOOTH
52	984049	1	NUT HEX 10-24
53	0110468	1	WIRE 16 FEM1871 FEM1871 4
54	0090622	4	WIRE 18 FEM1871 FEM2501 9
55	0181103	1	WIRE 16 R10 FEM250FI 18
56	0071557	1	WIRE 18 R81 MALE250FI 7
57	0071812	1	WIRE 16 R10 FEM250FI 18
58	0151816	1	WIRE 16 R101 R101 7.5
59	3040411	1	ALARM MINI SIREN 6-28VDC
60	5560609	10	SCREW THRD 10-24 .500
61	970029	2	BOLT .25-20 .750 GR5

## Upper Control Panel – CE

## Upper Control Panel – CE

Item	Part No.	Qty.	Description
62	5560004	2	NUT LKG .250-20
63	5569711	1	GROMMET .438ID .938OD .125
64	0073295	4	WIRE 16 R61 FEM250FI 8
65	5560673	2	SCREW THRD 10-24 1.00
66	0110598	1	WIRE 18
67	3026027	1	SWITCH PUSH BUTTON
68	7140092	1	STATOSEAL KIT PARTNER
69	0071269	1	DECAL HORN
70	0070733	1	WIRE 16 R81 R101 24
71	3040525	1	CONTROLLER SINGLE AXIS 63HZ
72	0181030	2	WIRE 16 FEM1881 FEM250FI 15
73	0071534	1	WIRE 10 R101 FEM1881 21
74	0172238	2	WIRE 16 R61 DIO 30
75	0172237	1	WIRE 16 FEM250FI DIO 16
76	0172236	3	WIRE 16 FEM1881 DIO 16
77	0073728	1	WIRE 16 R101 FEM1881 18
78	0172240	1	DIODE HOLDER
79	0073631	3	DIODE STAND OFF
80	0112797	1	DECAL, DIODES
83	5560609	8	SCREW #10-24 X .50 TRHD
84	3040300	1	CONN .50 .188-.313
85	3040070	1	LOCKNUT .50 HUB
86	3040082	1	TERMINAL MALE 250F1 16/14
88	0071840	1	WIRE 16 FEM1881 FEM1881 11
89	0111477	3	DIODE WIRE ASSY
90	0073884	1	WIRE 16 R61 FEM250FI 24
91	0071538	1	WIRE 18 R61 FEM1881 22
92	3020017	1	SWITCH TOGGLE DPDT (ON/OFF/ON) SEALED
93	239926	1	SWITCH TOGGLE SPDT (ON/OFF/ON) SEALED
100	0112551	1	PLACARD PLATFORM CONTROL BOX TOP
101	3020020	1	SWITCH EMERGENCY STOP PUSH/PULL
103	0070747	4	WIRE 16 R6I R6I 3
106	0070758	1	WIRE 16 R6I R10I 20
107	0182061	1	WIRE 16 6RI FEM1881 42
108	0181113	1	WIRE 16 R10I FEM250FI 9-25/25
109	0192089	2	WIRE
110	0192094	1	WIRE
111	0192090	1	WIRE
112	0081560	1	WIRE 16 R10I FEM250FI 12
113	0192086	1	WIRE 16 R10I NONE 25 WHT
114	0150756	1	WIRE 16 R8I FEM250FI 36
115	0130095	1	WIRE 16 FEM250FI FEM250FI 24
116	0151817	1	WIRE 12 R10I FEM250FI 13
117	0073056	1	WIRE 12 R10I R10I 6.5
118	0182062	2	WIRE 16 FEM250FI NONE 24
119	0101800	1	WIRE 16 FEM250I NONE 12
120	0182066	2	WIRE 16 3X MALE250FI 6
121	0073071	3	WIRE 18 R6I FEM250FI 28
122	3030165	1	LOAD LIMITER, CONTROL BOX
123	3040508	1	TIME DELAY MODULE
124	3040214	1	RELAY DPDT 12V 10AMP
125	0182067	1	WIRE 16 NONE NONE 2
126	0192093	1	WIRE
127	3040293	1	DIODE
128	3069524	1	LIGHT, RED LED 12V .69 DIA
129	0172248	1	WIRE 16 FEM1881 FEM1881 DIO 26
130	0161819E	1	DECAL, CE EMERGENCY LOWERING PROCEDURES
131	0084072E	1	DECAL, BRIEF OPERATING INSTRUCTIONS
132	0084071E	1	DECAL, ADDITIONAL OPERATING INSTRUCTIONS

## Upper Control Panel – CE



## Upper Control Panel – CE

Item	Part No.	Qty.	Description
133	0074589	1	WIRE 12 R6I R10I 34
134	0071517	2	WIRE 18 R6I FEM188I 13
135	0192009	1	WIRE 16 FEM188I NONE 10
136	0071557	2	WIRE 16 R6I R6I 30
137	0075256	1	WIRE 18
138	0071528	1	WIRE 18 FEM250FI FEM188I 21
139	0071556	2	WIRE 16 R10I FEM250I 24
140	0101299	1	WIRE 18 R6I R6I 17
141	5560288	2	SCREW SLFTPG .250 .50 TYPE B
142	3020097	1	SWITCH TOGGLE DPDT ON/ON SEALED

## Upper Control Panel – CE



## Platform Foot Switch

Item	Part No.	Qty.	Description
1	007180028	1	PLATFORM FOOT SWITCH
	3020021	1	FOOT SWITCH
	3020037	1	REPLACEMENT SWITCH, SQUARE D SWITCH, 4 POLE – NOT SHOWN
	3020113	1	REPLACEMENT SWITCH, SQUARE D SWITCH, 8 POLE
2	0070596	1	WIRE HARNESS, PLATFORM FOOT SWITCH
3	3040116	1	CONNECTOR
4	3040110	1	CONNECTOR LOCKNUT
5	0070967	1	CORROSION INHIBITOR
6	0060373	1	JUMPER STRAP

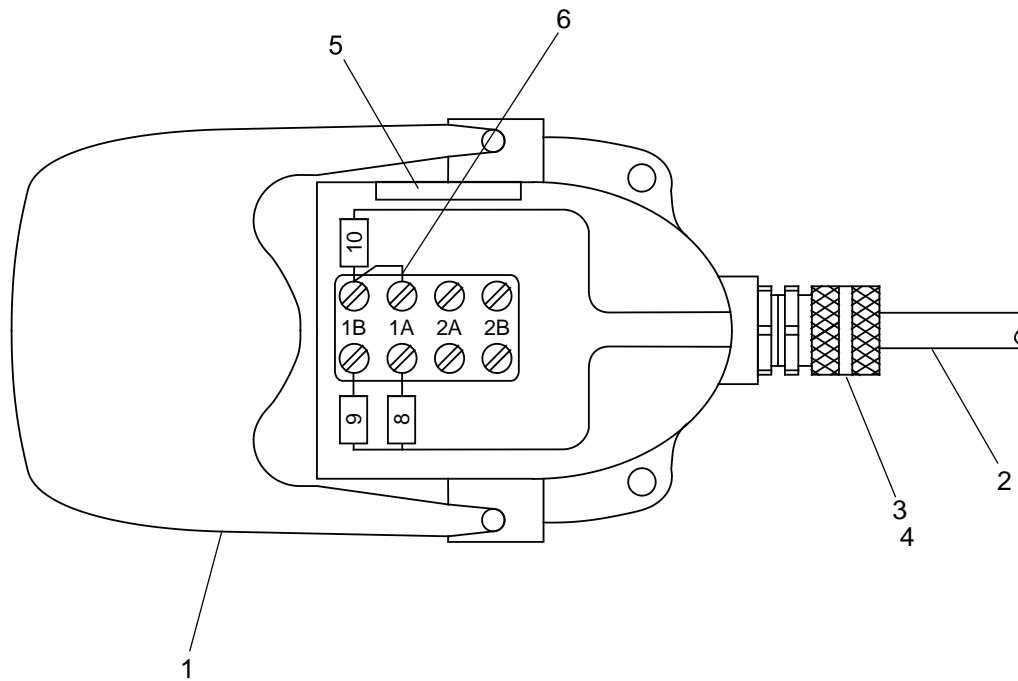

AW0071800

## Platform Foot Switch



## Boom Switch

Item	Part No.	Qty.	Description
1	0112997	1	SWITCH ASSEMBLY
2	3020019	1	SWITCH
3	0111890	1	WIRE HARNESS, BOOM SWITCH
4	3040187	1	CONNECTOR
5	3040070	1	CONNECTOR LOCKNUT
5	0070747	1	WIRE

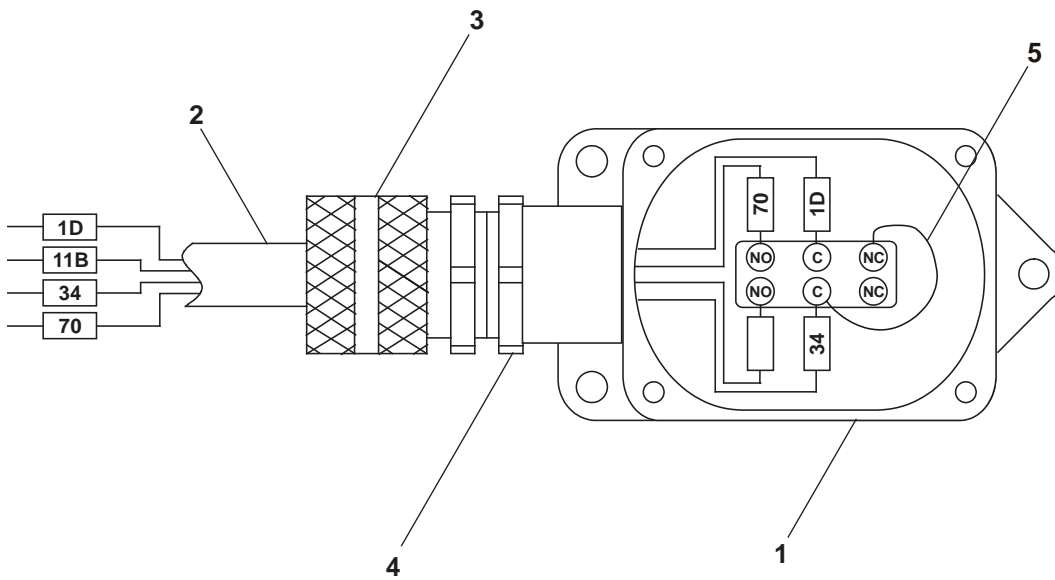

Aw0112997

## Boom Switch



## Boom Extend Switch

Item	Part No.	Qty.	Description
1	3020019	1	SWITCH
2	0111891	1	WIRE ASSEMBLY, BOOM EXTEND SWITCH
3	3040187	1	CONNECTOR
4	3040070	1	LOCKNUT

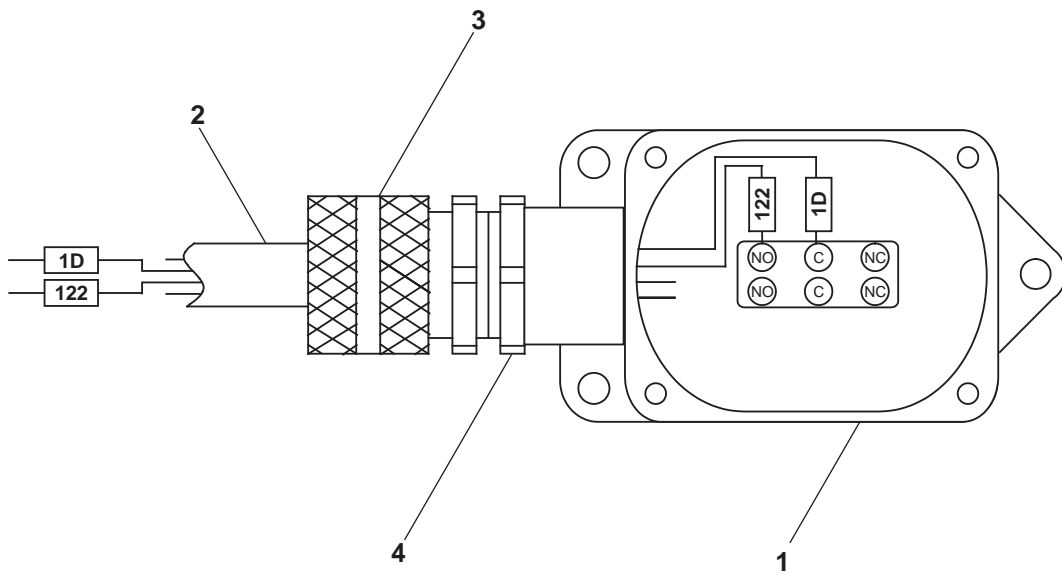

AW011889

## Boom Extend Switch





# Controller, Drive/Steer

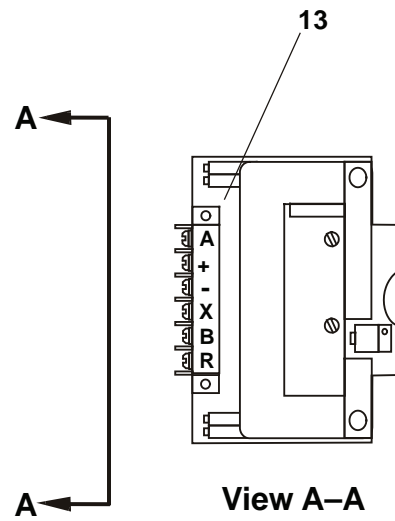
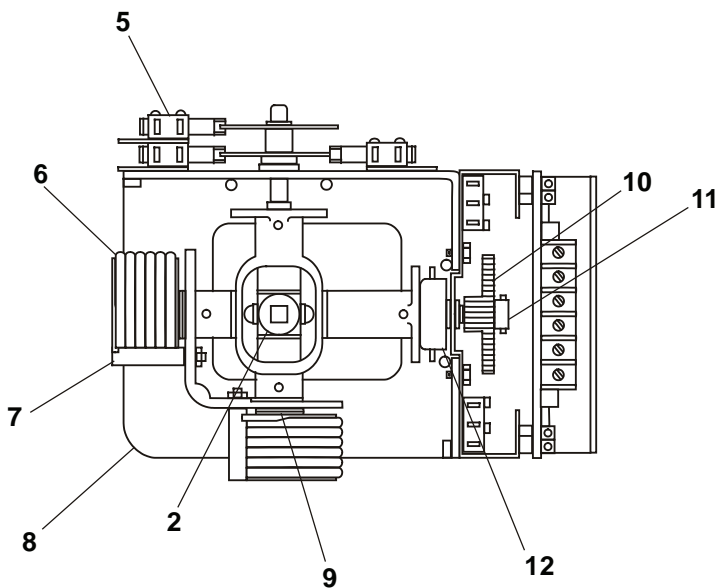
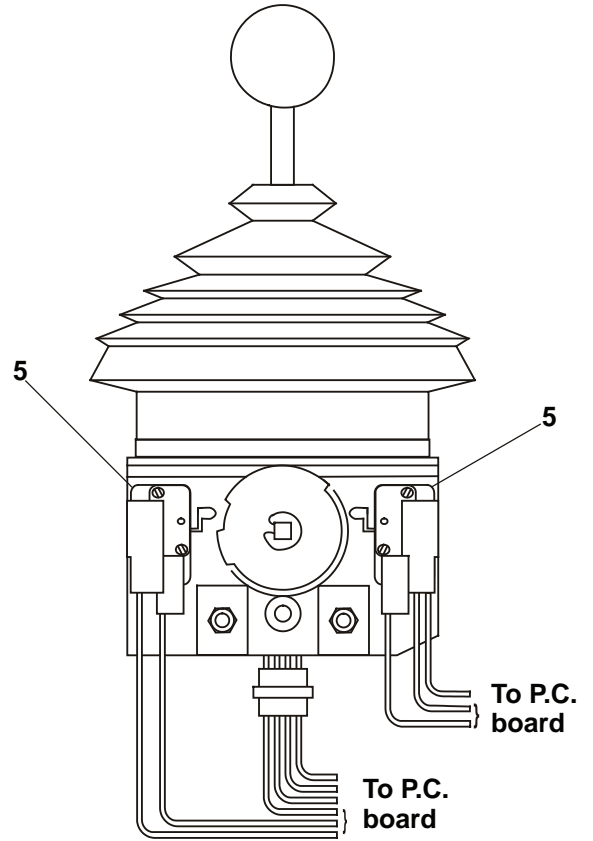
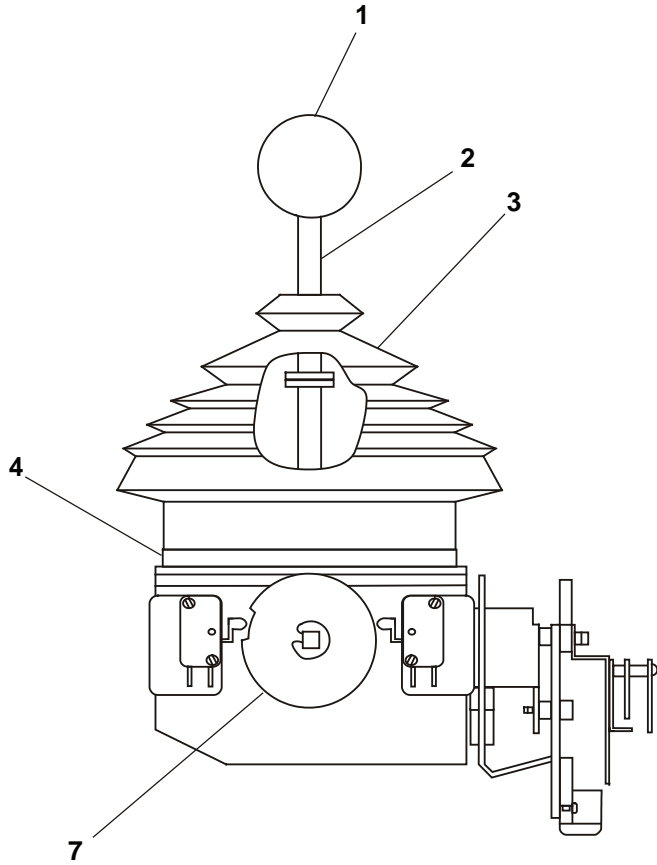

# Controller, Drive/Steer

## Controller, Drive/Steer

Item	Part No.	Qty.	Description
	304049228	1	CONTROLLER, DRIVE/STEER
1	2660002	1	KNOB
2	3040086	1	SHAFT
3	3040146	1	BOOT
4	3040169	1	BOOT CLAMP RING
5	3020033	6	MICROSWITCH
6	8150005	2	SPRING RETURN WITH HOUSING
7	8150004	2	SPRING RETURN BOLT
8	8150003	1	CASTING, MODIFIED
9	3040271	4	BUSHING
10	3040073	1	DRIVE GEAR
11	3040072	1	SLAVE GEAR
12	3040392	1	POT WITH BRACKET AND CONNECTOR
13	3220073	1	CIRCUIT BOARD

## Controller, Drive/Steer

# Controller, Lift/Swing

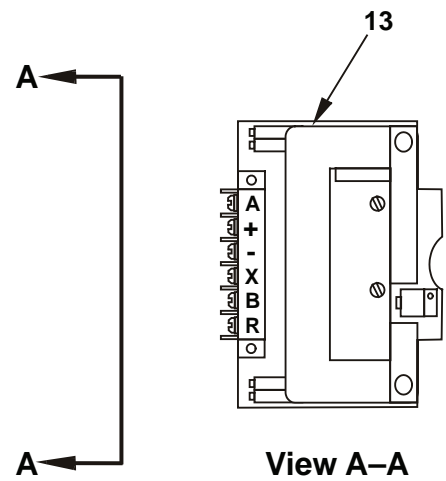
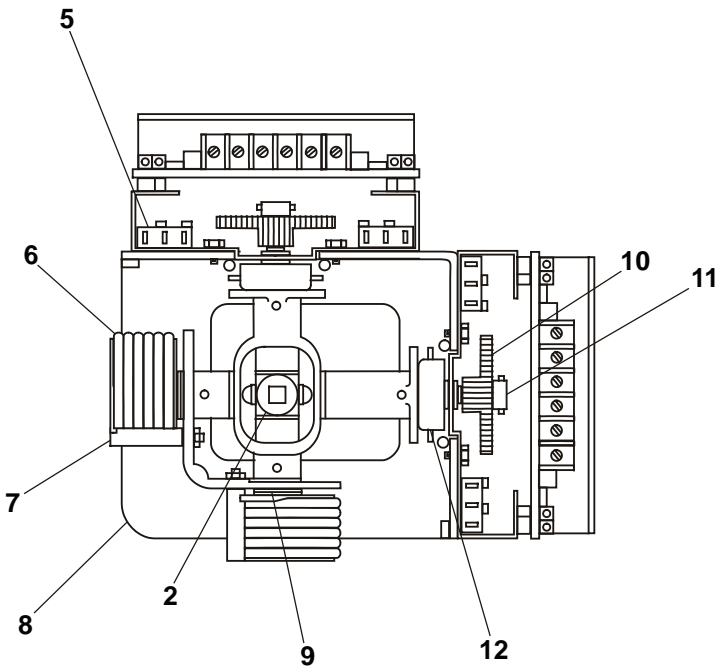
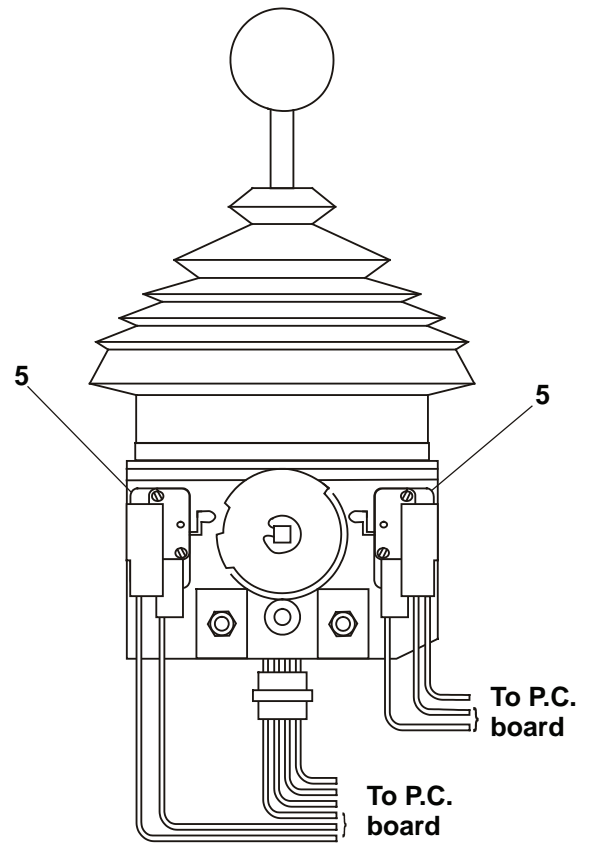
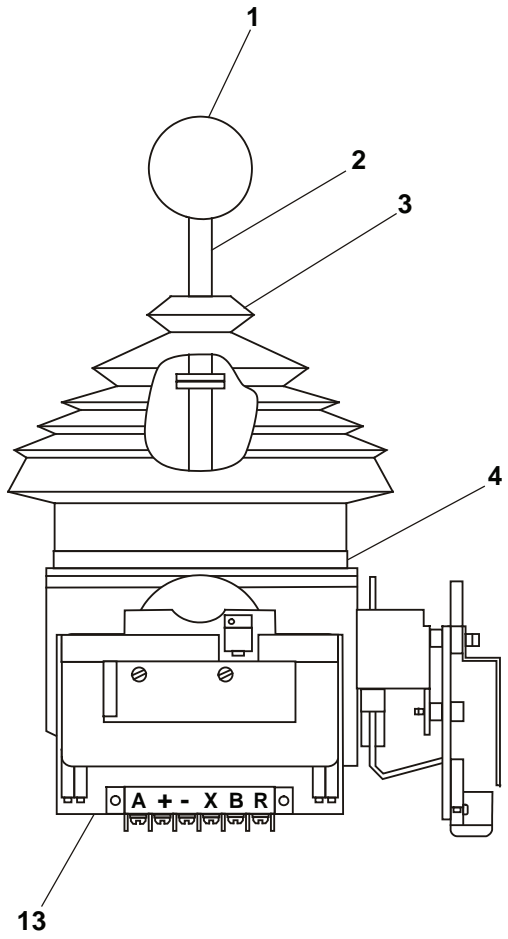

# Controller, Lift/Swing

AW3040378

## Controller, Lift/Swing

Item	Part No.	Qty.	Description
	304049328	1	CONTROLLER, LIFT/SWING
1	2660002	1	KNOB
2	3040086	1	SHAFT
3	3040146	1	BOOT
4	3040169	1	BOOT CLAMP RING
5	3020033	4	MICROSWITCH
6	8150005	2	SPRING RETURN WITH HOUSING
7	8150004	2	SPRING RETURN BOLT
8	8150003	1	CASTING, MODIFIED
9	3040271	4	BUSHING
10	3040073	2	DRIVE GEAR
11	3040072	2	SLAVE GEAR
12	3040392	2	POT WITH BRACKET AND CONNECTOR
13	3220073	1	CIRCUIT BOARD

## Controller, Lift/Swing

# Controller, Extend/Retract

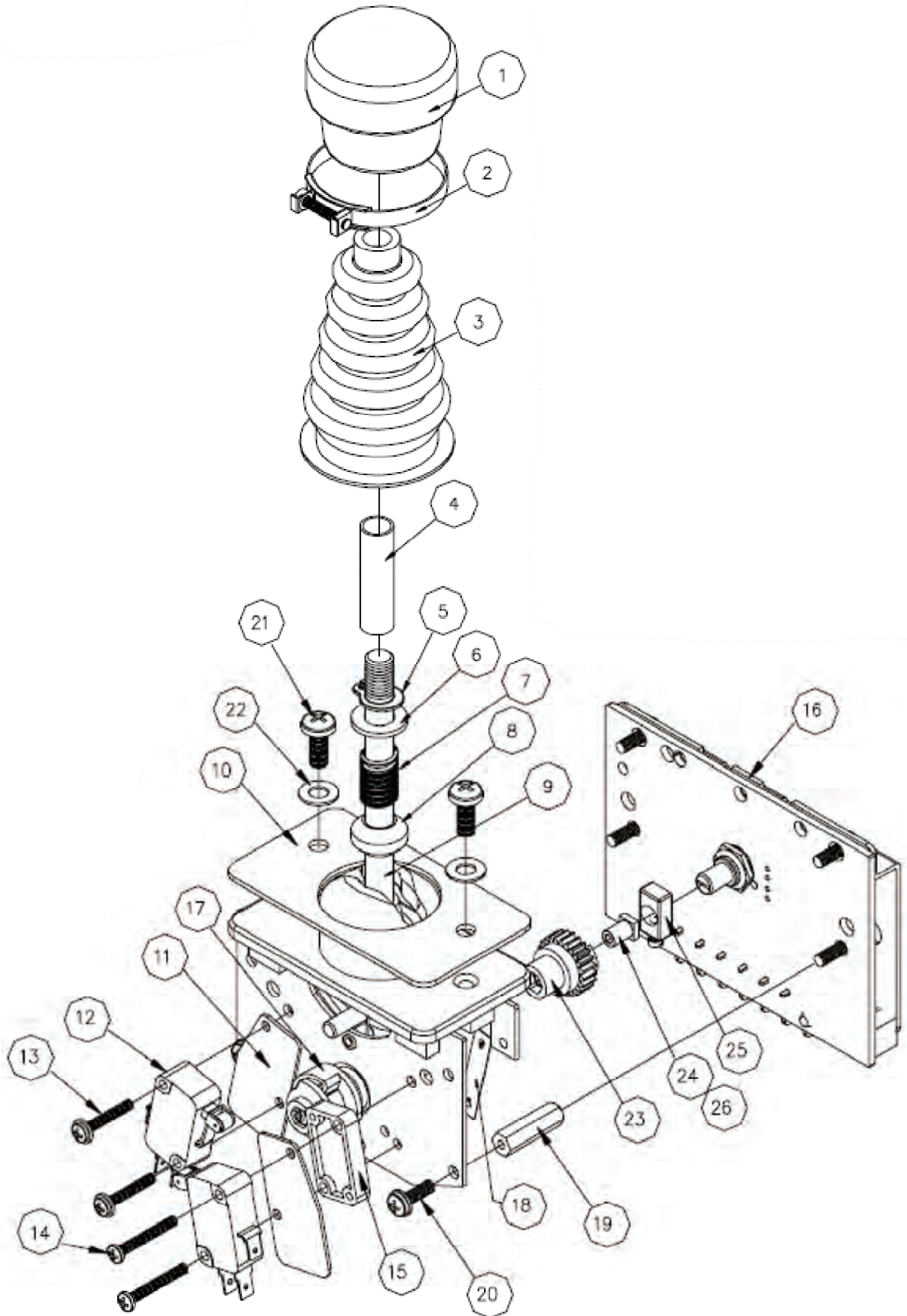

3220078

# Controller, Extend/Retract

## Controller, Extend/Retract

Item	Part No.	Qty.	Description
	3040525	1	CONTROLLER, SINGLE AXIS
1	8150087	1	HANDLE
2	8150091	1	BEZEL
3	3040259	1	BOOT
4	8150215	1	SLEEVE
5	8150146	1	TENSION CLIP
6	8150205	1	WASHER
7	8150216	1	SPRING HEAVY DUTY
8	8150217	1	DETENT
9	8150087	1	HANDLE
10	8150220	1	GASKET
11	3020191	2	INSULATOR
12	8150202	2	MICROSWITCH
13		2	SCREW
14		2	SCREW
15	8150129	1	SPACER
16	8150210	1	PCB OR POT ASSEMBLY
17		1	CAM ASSEMBLY
18	8150218	1	TINNERMAN NUT
19	8150255	2	FLANGE MOUNT
20	8150206	6	SCREW
21	8150222	2	SCREW
22	8150213	2	WASHER
23	8150246	1	SLAVE GEAR
24	8150219	1	CAM ASSEMBLY NUT
25	8150200	1	POT COUPLING ASSEMBLY
26	3020194	1	CAM NUT

## Controller, Extend/Retract

## GFCI 110 Volt Power

Item	Part No.	Qty.	Description
1	3040252	1	CIRCUIT BREAKER, 15 AMP CAPACITY
2	0071582	1	JUMPER WIRE
3	3040624	1	RECEPTACLE, GFCI OUTLET - 20 AMP
4	3040691	1	CONNECTOR
5	0074368	1	CABLE, 110 V POWER TO PLATFORM - (USED ON ALUMINUM PLATFORMS ONLY)
6	3040116	1	CONNECTOR
7	3040110	1	CONNECTOR LOCKNUT
8	0074379	1	ELECTRICAL BOX, DRILLED
9	3040625	1	COVER, GFCI OUTLET
10	0074369	1	CABLE, 110 V POWER TO PLATFORM - (USED ON STEEL PLATFORMS ONLY)

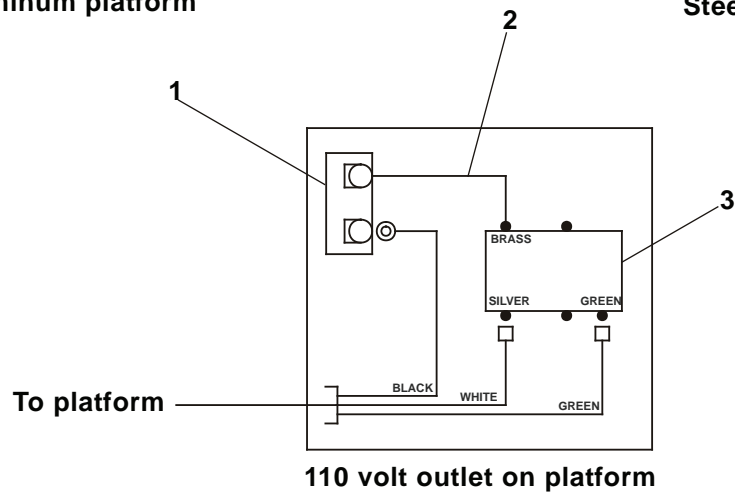
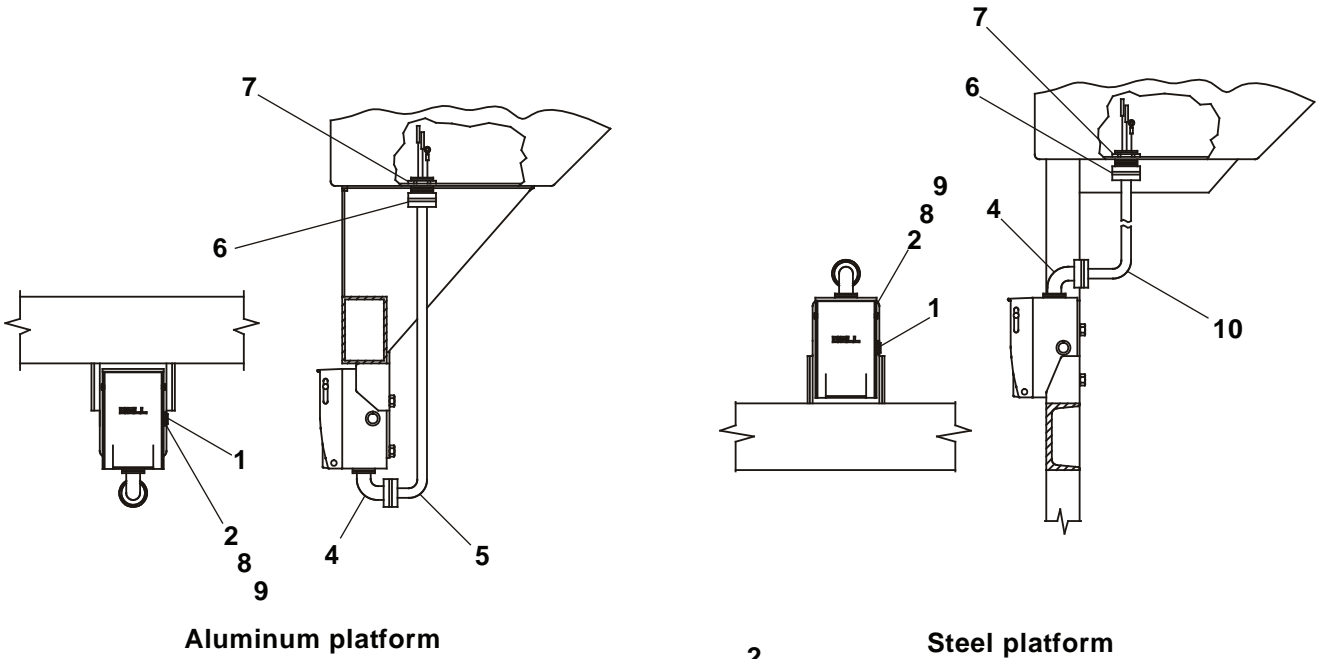

AW007034

## GFCI 110 Volt Power





# *Options*

TB80

TB85J



 **snorkel**



# Dual Fuel

Item	Part No.	Qty.	Description
1	0112638	1	OPTION, GAS ONLY
2	0080668	1	MOUNTING BRACKET
3	9940018	1	LP GAS CYLINDER
4	0070969	2	BRACKET ASSEMBLY, LP CYLINDER
5	0072177	1	5/16 ID HOSE ASSEMBLY
6	0080676	1	5/16 ID HOSE ASSEMBLY
7	7630703	1	HYDROSTATIC RELIEF VALVE
8	5090049	1	CONNECTOR
9	7630704	1	BULKHEAD TEE
10	3020047	1	SWITCH TOGGLE
11	0081441	1	PLACARD, LIQUID WITHDRAWAL
12	0070974	1	COUPLER, FEMALE
13	986269	1	WASHER, FLAT 5/16
14	5560031	1	NUT, 5/16-18
15	5093004	2	CLAMP (.75)
16	970259	1	CAPSCREW, 5/16-18 X 1 LG HH
17	5560655	4	POP RIVET
18	5560033	8	NUT, 3/8-16
19	986019	1	WASHER, FLAT 1/4
20	972489	8	CAPSCREW, 3/8-16 X 1-1/2 LG HH
21	986299	8	WASHER, FLAT 3/8
22		1	CAPSCREW, 1/4-20 X 3/4 LG HH
23	5560004	1	NUT, 1/4-20

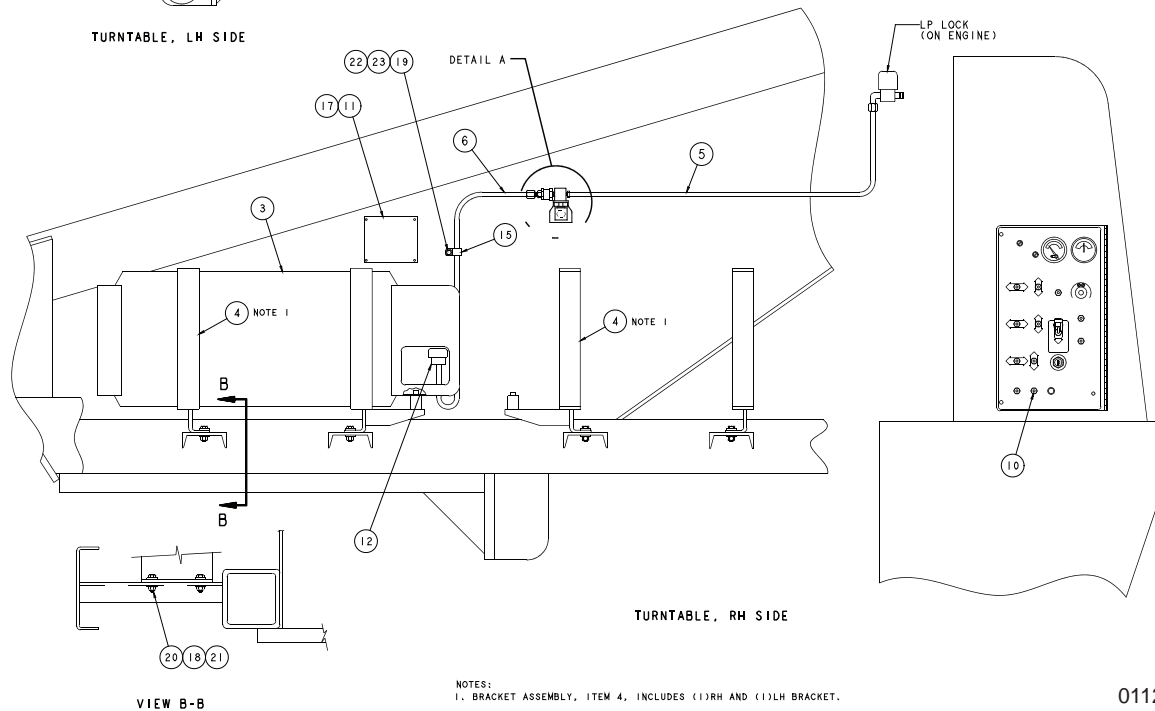
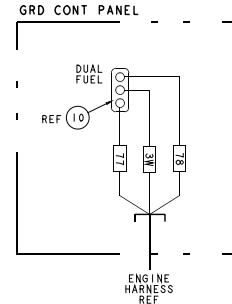
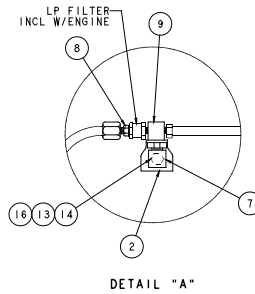
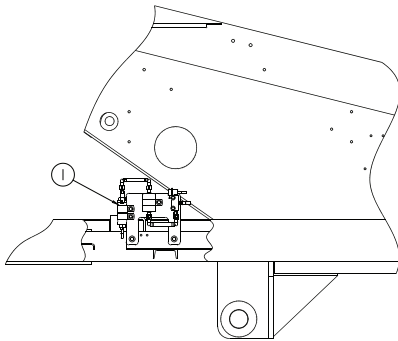

0112636

# Dual Fuel



# LP Fuel Only

Item	Part No.	Qty.	Description
1	5550028	2	CLAMP
2	0080668	1	MOUNTING BRACKET
3	9940018	1	LP TANK FILLED 43.5# LIQ
4	0070969	2	BRACKET ASSEMBLY - LP CYLINDER
5	0072177	1	5/16 ID HOSE ASSEMBLY
6	0080676	1	5/16 ID HOSE ASSEMBLY
7	7630703	1	HYDROSTATIC RELIEF VALVE
8	5090049	1	CONNECTOR
9	7630704	1	BULKHEAD TEE
10	5010011	.16 FT	HOSE, FUEL .313 ID
11	0081441	1	PLACARD, LIQUID WITHDRAWAL
12	0070974	1	COUPLER, FEMALE
13	986269	1	WASHER, FLAT 5/16
14	5560031	1	NUT, 5/16-18
15	5093004	2	CLAMP
16	975309	2	CAPSCREW 5/16-18 X 1.00 LG HH
17	5560655	4	POP RIVET
18	5560003	8	NUT, 3/8-16
19	986019	1	WASHER, 1/4 FLAT
20	975419	8	CAPSCREW 3/8-16 X 1 1/2 LG HH
21	986299	8	WASHER, FLAT 3/8
22	975089	1	CAPSCREW 1/4-20 X 3/4 LG HH
23	5560004	1	NUT, 1/4-20
24	3044070	1	TERM BUTT CONN INSUL 22/18
25	0081377	1	DECAL, LPS LOGO

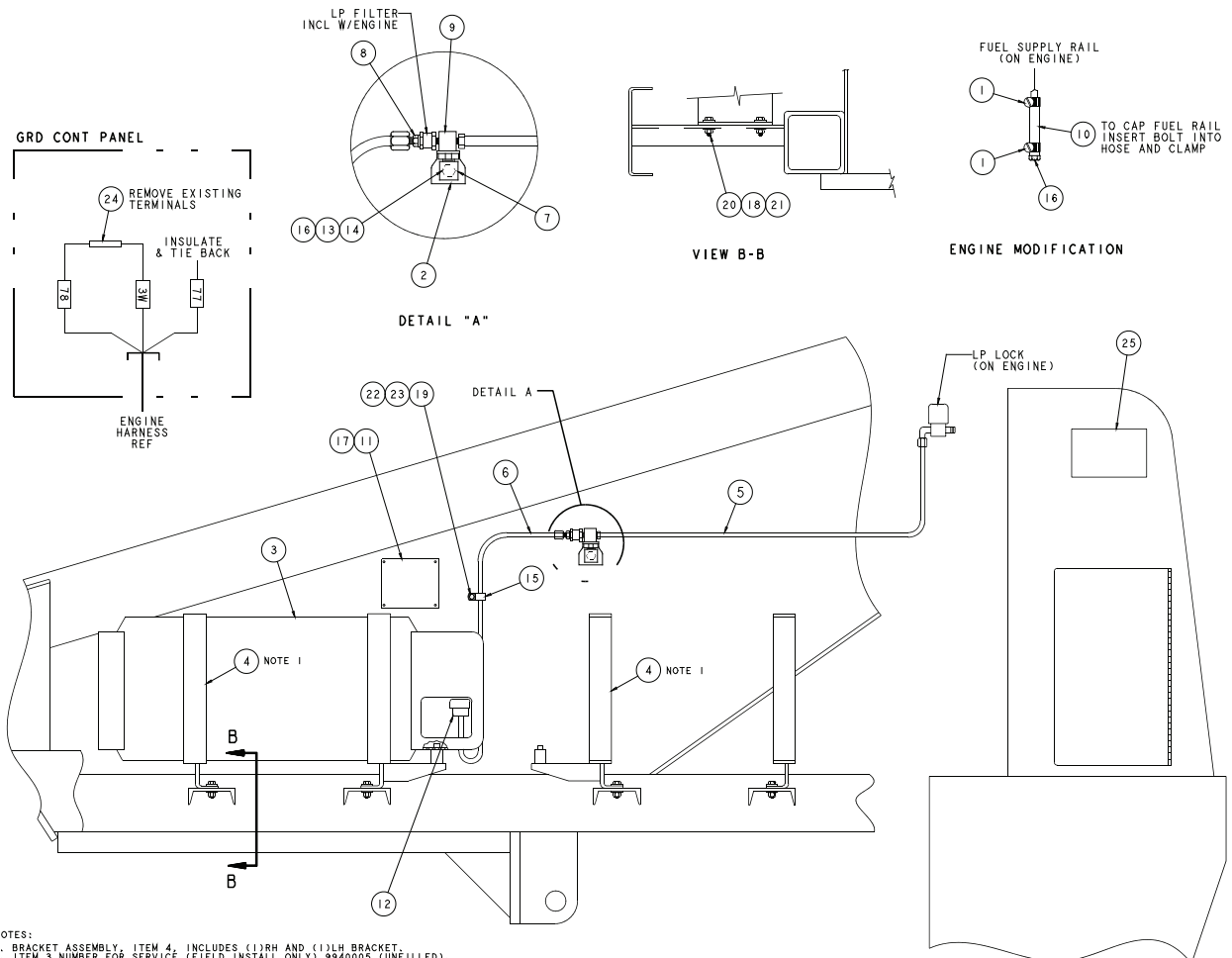

NOTES:  
 1. BRACKET ASSEMBLY, ITEM 4, INCLUDES (1)RH AND (1)LH BRACKET.  
 2. ITEM 3 NUMBER FOR SERVICE (FIELD INSTALL ONLY) 9940005 (UNFILLED).

TURNTABLE, RH SIDE

## LP Fuel Only

0112637



# Gasoline Only

Item	Part No.	Qty.	Description
1	0112966	1	ASSEMBLY, FUEL PUMP
2	5098341	1	FTG ADAPTER BARBED-2H-4N BR
3	5010007	11 FT	HOSE VACUUM .156 ID
4	0112968	1	HOSE ASSEMBLY FUEL .38 ID X 114.00
5	0112969	1	HOSE ASSEMBLY FUEL .38 ID X 108.00
6	0112970	1	HOSE ASSEMBLY FUEL .38 ID X 120.00
7	7714203	2	FTG PLUG-6N
8	0075445	1	ASSEMBLY, FUEL PICKUP FTG-6N-4N
9	5090021	1	FTG ELB 90 STREET -6N BR
10	7714535	1	FTG REDUCER BSHG-6N-4N BR
11	970469	2	BOLT, HEXHD .375-16 X 1.00
12	5560003	2	NUT, LKG .375-16
13	986299	5	WASHER, FLAT .375
14	3044070	1	TERM BUTT CONN INSUL 22/18
15	0112967	1	FUEL LEVEL GAUGE
16	0112971	1	FUEL TANK INSTALL
17	5039002	1	CLAMP
18	970429	1	BOLT, HEXHD .375-16 X .50
19	987119	1	WASHER LOCK .375

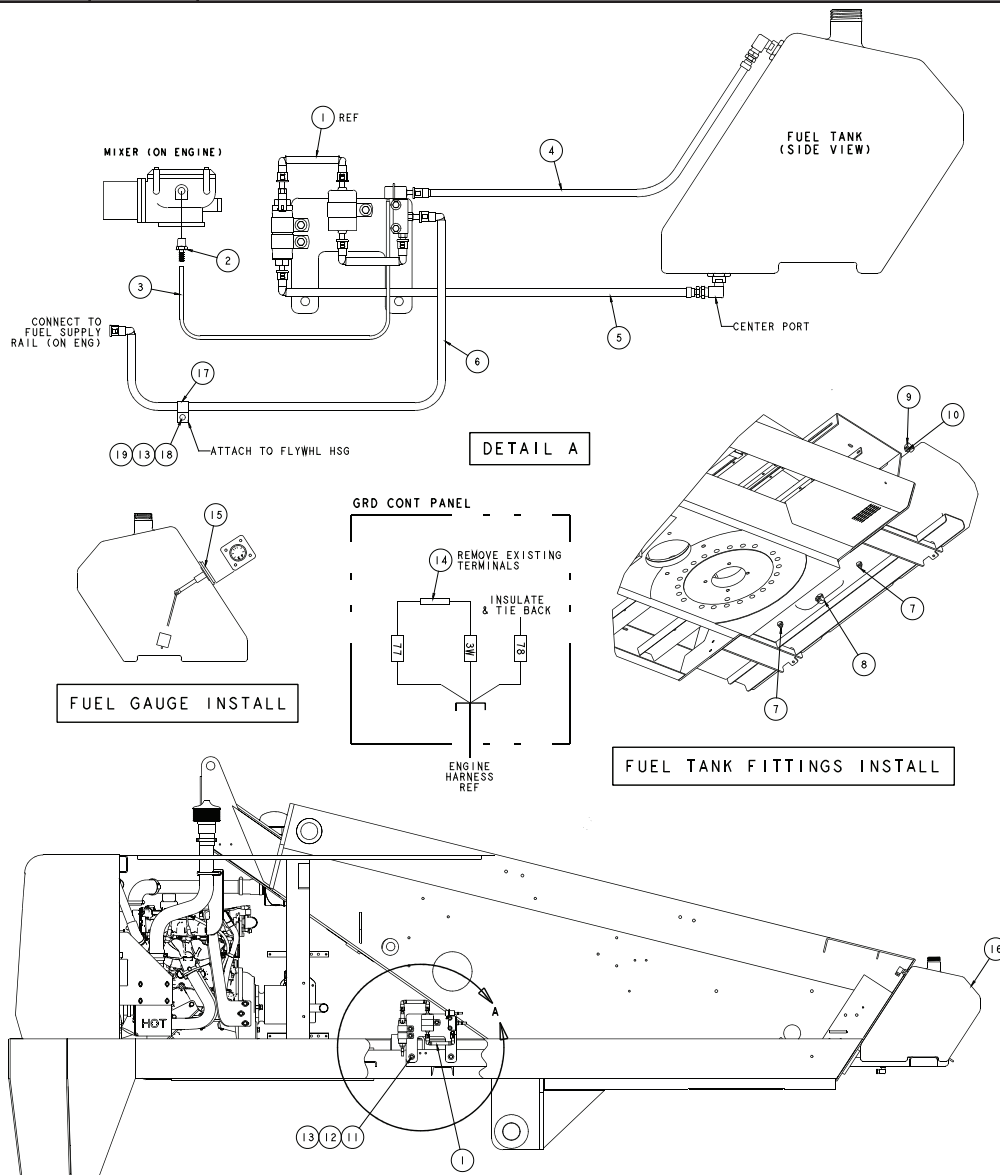

# Gasoline Only

0112638





# 110 V AC Generator Mounting

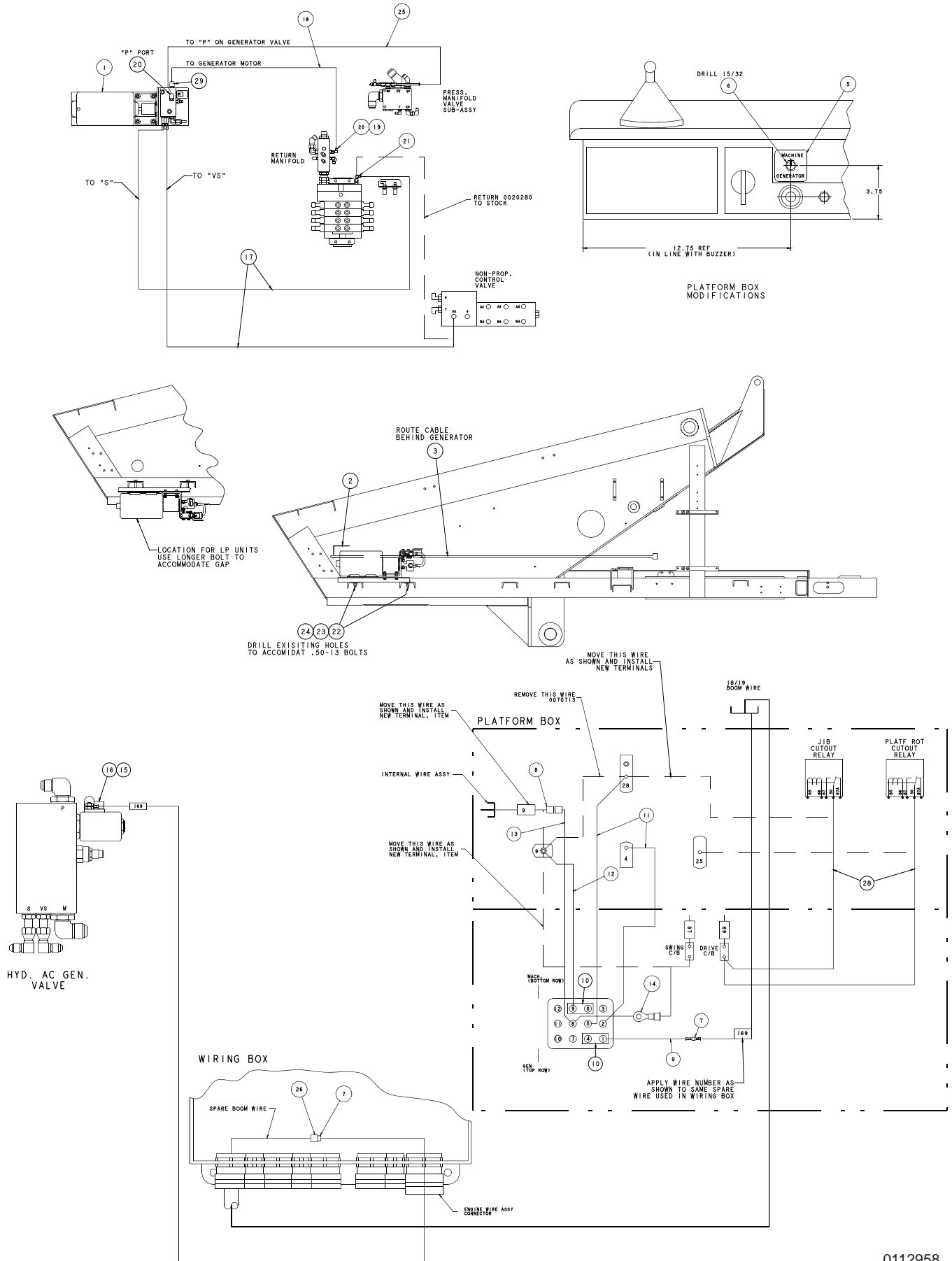

0112958

# 110 V AC Generator Mounting

## 110 V AC Generator Mounting

Item	Part No.	Qty.	Description
1	0151471	1	HYD AC GENERATOR SUB-ASSY
2	0073163	1	GUARD, CABLE RETENTION
3	0112047	1	110 V. POWER CABLE
4	0151583		START UP AND TEST PROCEDURE
5	0151459	1	PLACARD
6	3020048	1	SWITCH
7	3040046	2	TERMINAL .250 MALE FI 22/18 WIRE
8	3040064	1	TERMINAL .250 MALE FI 12/10 WIRE
9	0090757	1	WIRE 16 R61 FEM250FI 3
10	0060373	2	JUMPER SWITCH TERMINAL STRAP
11	0071517	2	JUMPER WIRE
12	0071541	1	JUMPER WIRE
13	0181187	1	JUMPER WIRE
14	3044158	1	TERMINAL #6 STUD, INS 16/14 WIRE
15	3044146	1	TERMINAL #10 STUD, INS 22/18 WIRE
16	3040452	1	BOOT
17	0070771	2	HOSE -4-4S-4S 77 100R1
18	0080362	1	HOSE -6-6S-6S 93.5 100R2
19	5065708	1	FTG ADAPTER STRTHD-8B
20	5037005	2	FTG ELB90SWVL-6S-6S
21	5037003	1	FTG EBL90SWVL-4S-4S STL
22	970029	2	BOLT HEXHD .50-13 X 1.5 LG
23	986359	2	WASHER .50 FLAT
24	5560039	2	NUT .50-13 ESNA
25	0111286	1	HOSE -6-6S-6S 84 100R2
26	3040047	1	TERMINAL .250 FEM FI 22-18 WIRE
27	0073884	2	WIRE 16 R61 FEM250FI 24
28	5035320	1	FTG EBL90STRTHD-8B-6S STL

## 110 V AC Generator Mounting

# 110 V AC Generator

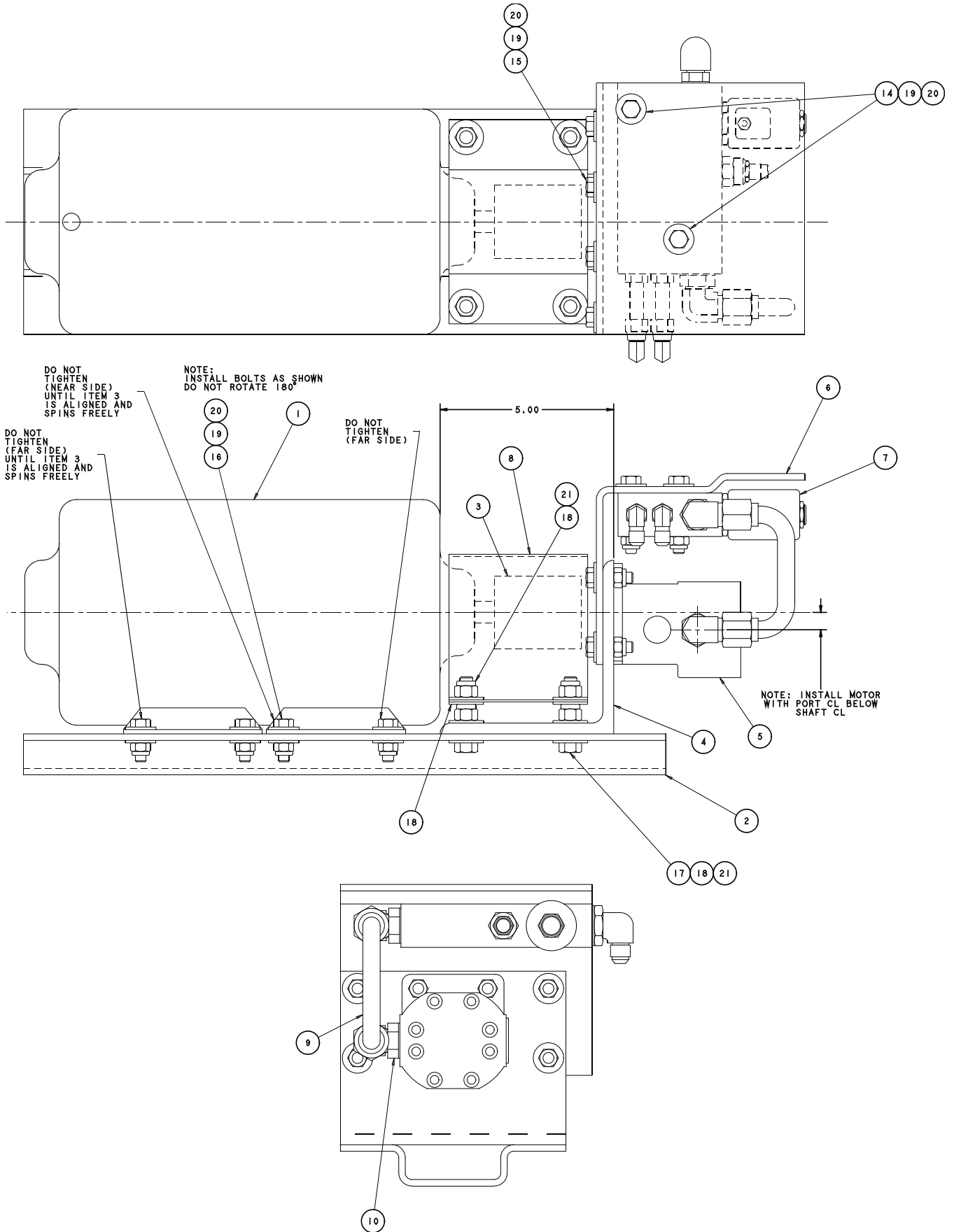

# 110 V AC Generator

0151471

## 110 V AC Generator

Item	Part No.	Qty.	Description
1	3080001	1	GENERATOR
2	0151457	1	MOUNT PLATE
3	7240012	1	COUPLING
4	0151458	1	MOUNTING ANGLE, MOTOR
5	6030029	1	MOTOR, HYDRAULIC
6	0151469	1	MOUNTING BRACKET, VALVE
7	0152831	1	AC VALVE SUBASSY
8	0151484	1	COVER, COUPLING
9	0151470	1	1/2" OD TUBE ASSEMBLY
10	5035306	1	ELBOW 90 STRT THRD, -8-8
14	970299	2	CAPSCREW 5/16-18 X 2 LG HH
15	970269	8	CAPSCREW 5/16-18 X 1-1/4 LG HH
16	970369	8	CAPSCREW 5/16-18 X 1 LG HH
17	970469	4	CAPSCREW 3/8-16 X 1 LG HH
18	986299	12	WASHER 3/8 FLAT
19	986269	30	WASHER 5/16 FLAT
20	5560031	18	NUT, 5/16-18 ESNA
21	5560033	8	NUT, 3/8-16 ESNA

## 110 V AC Generator

# 220 V AC Generator Mounting

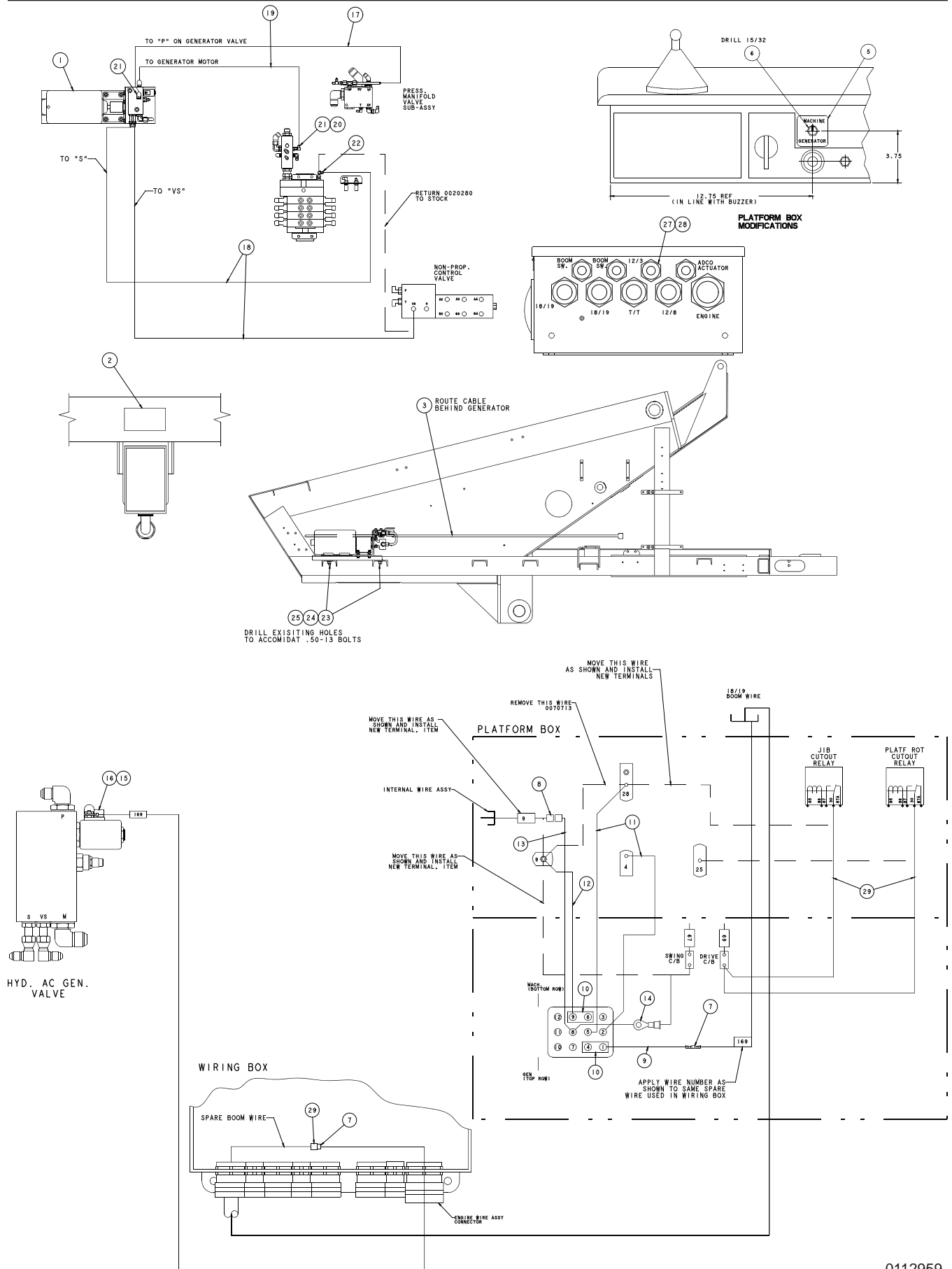

# 220 V AC Generator Mounting

0112959

## 220 V AC Generator Mounting

Item	Part No.	Qty.	Description
1	0074981	1	HYD AC GENERATOR SUB-ASSY
2	0182055	2	DECAL, 220V 50HZ 10A
3	0112614	1	220V POWER CABLE
4	0151583		START UP AND TEST PROCEDURE
5	0151459	1	PLACARD
6	3020048	1	SWITCH
7	3040046	2	TERMINAL .250 MALE FI 22/18 WIRE
8	3040064	1	TERMINAL .250 MALE FI 12-10 WIRE
9	0090757	1	WIRE 16 R61 FEM250FI 3
10	0060373	2	JUMPER, SWITCH TERMINAL STRAP
11	0071517	2	JUMPER WIRE
12	0071541	1	JUMPER WIRE
13	0181187	1	JUMPER WIRE
14	3044158	1	TERMINAL #6 STUD INS 16/14 WIRE
15	3044146	1	TERMINAL #10 STUD INS 22/18 WIRE
16	3040452	1	BOOT
17	0111286	1	HOSE -6-6S-6S 84 100R2
18	0070771	2	HOSE -4-4S-4S 77 100R1
19	0080362	1	HOSE -6-6S-6S 93.5 100R2
20	5065708	1	FTG ADAPTER STRTHD -8B
21	5037005	2	FTG ELB90SWVL-6S-6S
22	5037003	1	FTG ELB90SWVL-4S-4S STL
23	970029	2	BOLT .50-13 X 1.50 LG
24	986359	2	WASHER .50 FLAT
25	5560039	2	NUT .50-13
26	3040047	1	TERMINAL .250 FEM FI 22/18 WIRE
27	3040110	1	NUT LKG .750 HUB
28	3040295	1	CONNECTOR .750 .625-.750
29	0073884	2	WIRE 16 R61 FEM250FI 24

## 220 V AC Generator Mounting

# 220 V AC Generator

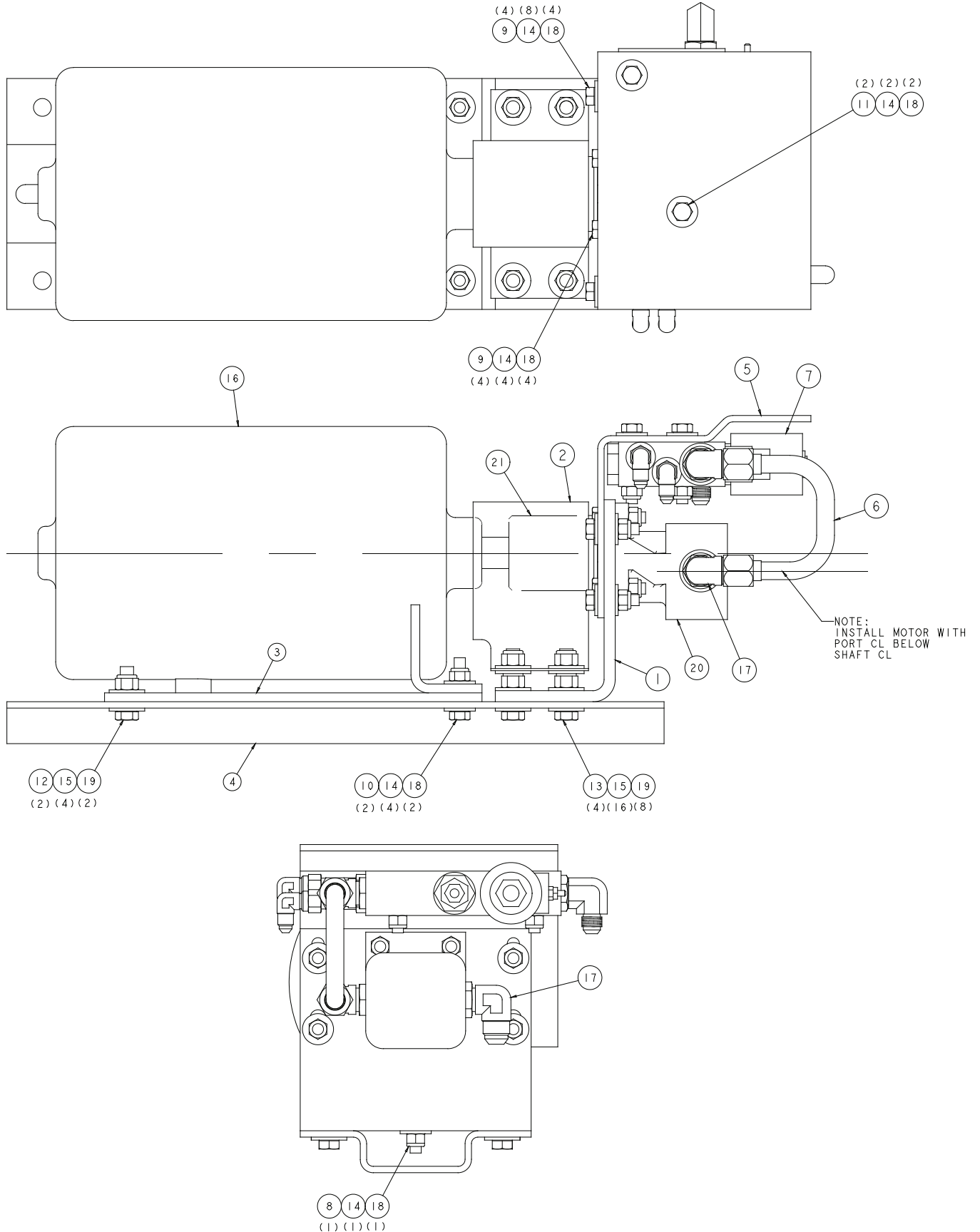

# 220 V AC Generator

0074981

## 220 V AC Generator

Item	Part No.	Qty.	Description
1	0074983	1	MOUNT ANGLE
2	0074984	1	COVER, CPLG
3	0074985	1	SPACER PLATE
4	0151457	1	MOUNT PLATE
5	0151469	1	MOUNTING BRACKET
6	0151470	1	TUBE ASSEMBLY
7	0152831	1	AC GENERATOR VALVE SUB ASSEMBLY
8	970259	1	BOLT .313-18 1.00
9	910269	8	BOLT .313-18 1.25 GR5
10	970279	2	BOLT .313-18 1.50
11	970299	2	BOTL .313-18 2.00
12	970419	2	BOLT .375-16 1.25 GR5
13	970499	4	BOLT .375-16 1.75 GR5
14	986269	19	WASHER FLAT .313
15	986299	20	WASHER FLAT .38
16	3087785	1	GENERATOR
17	5035306	2	FTG ELB90STRTHD-8B-8S STL
18	5560031	13	NUT LKG .313-18
19	5560333	10	NUT LKG .375-16
20	6030029	1	HYDRAULIC MOTOR
21	7249577	1	FLEXIBLE COUPLING

## 220 V AC Generator



## AC Generator Valve

Item	Part No.	Qty.	Description
	015283128	1	AC GENERATOR VALVE
1	6010489	1	AC GENERATOR VALVE - (INCLUDES ITEMS 2, 3 AND 4 - VALVE IS NOT PRESET)
2	6010508	1	CARTRIDGE VALVE WITH COIL
	6010509	1	REPLACEMENT CARTRIDGE VALVE WITHOUT COIL
	3040457	1	REPLACEMENT COIL, 12 VOLT DC
3	6018901	1	FLOW CONTROL VALVE CARTRIDGE
4	6010510	1	SHUTTLE VALVE CARTRIDGE
5	5065803	2	LONG STRAIGHT THREAD ADAPTER
6	5037003	2	SWIVEL NUT 90° ELBOW
7	5035306	1	STRAIGHT THREAD 90° ELBOW
8	5035320	1	STRAIGHT THREAD 90° ELBOW

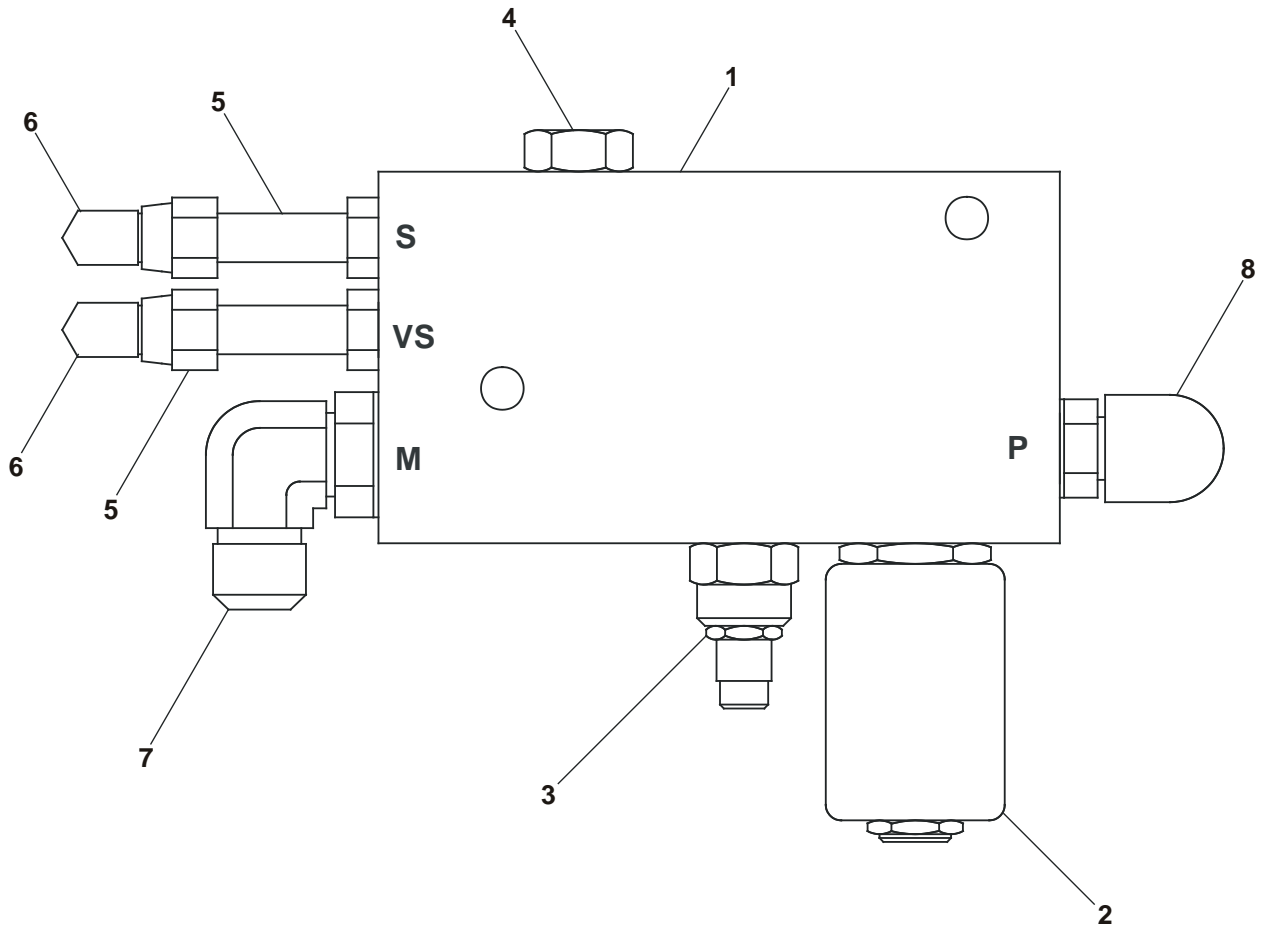

AW0152831

## AC Generator Valve



# 12 kw Generator

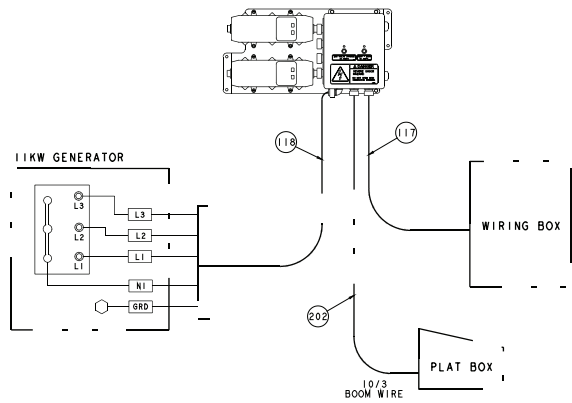
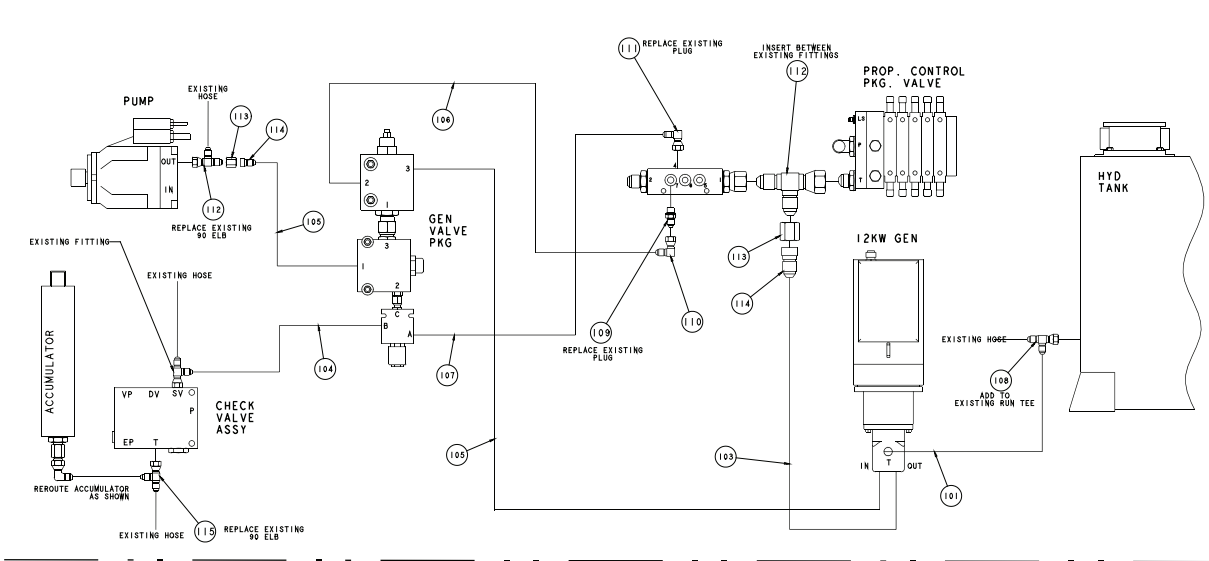
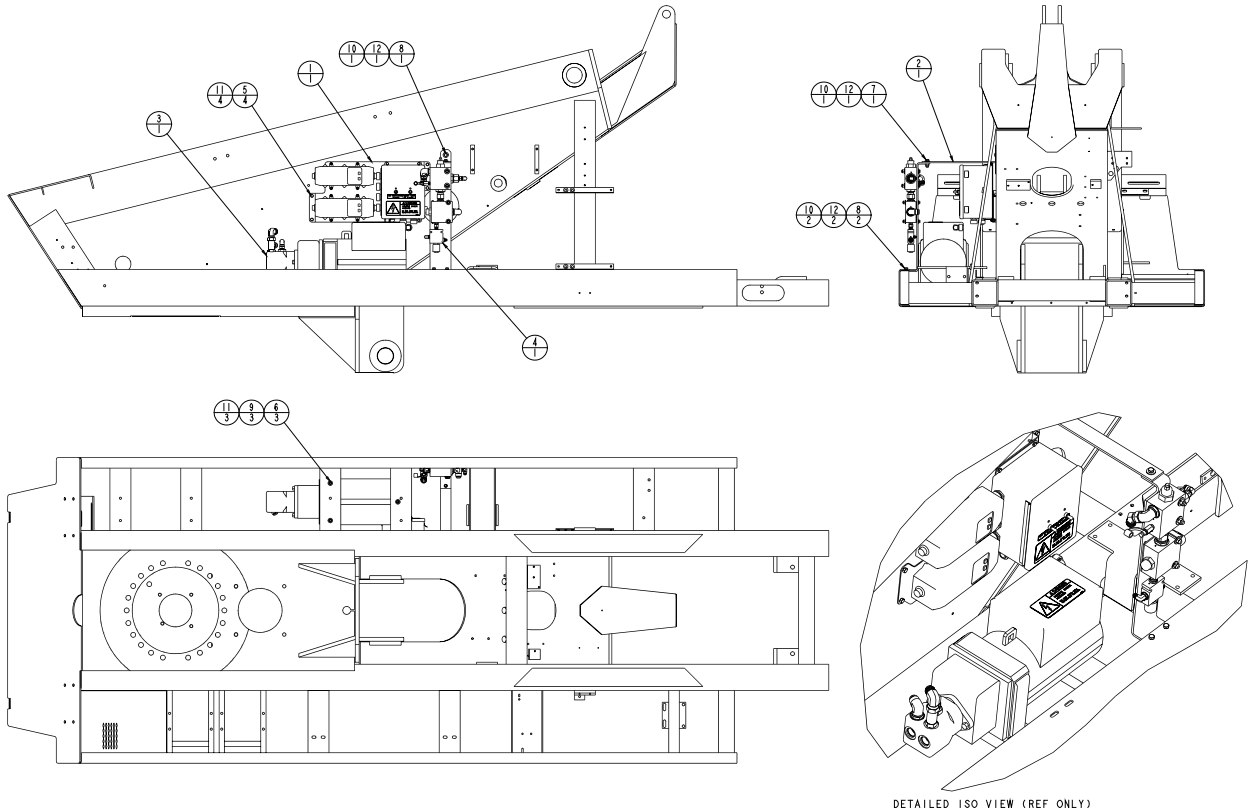

# 12 kw Generator

0112596

## 12 kw Generator

Item	Part No.	Qty.	Description
1	0083966	1	ASSEMBLY, 12KW GENERATOR CIRCUIT BREAKER WIRING
2	0112579	1	BRACE, VALVE BRACKET 12KW GENERATOR
3	0112580	1	ASSEMBLY, 12 KW GENERATOR
4	0112581	1	ASSEMBLY, VALVE 12 KW GENERATOR
5	970259	4	BOLT, HEXHD .313-18 1.00
6	970269	3	BOLT, HEXHD .313-18 1.25 GR5
7	970419	1	BOLT, HEXHD .375-16 1.25 GR5
8	970489	3	BOLT, HEXHD .375-16 1.50
9	986269	3	WASHER FLAT .313
10	986299	4	WASHER FLAT .38
11	5560031	7	NUT LKG .313-18
12	5560033	4	NUT LKG .375-16
101	0110732	1	HOSE -8-8S-8S 72
103	0110173	1	HOSE -12-12S-12S 41
104	0100278	1	HOSE -4-4S-4S 43
105	0110171	1	HOSE -6-6S-6S 22
106	0020270	1	HOSE -6-6S-6S 22
107	0050137	1	HOSE -4-4S-4S 36
108	5036706	1	FTG TEE SWVLRUN -8S-8S
109	5065705	1	FTG ADAPTER STRTHD -6B-6S
110	5037003	1	FTG ELB90SWVL -4S-4S
111	5035305	1	FTG ELB90STRTHD -6B-6S STL PH6
112	5036710	2	FTG TEE SWVL RUN-16S-16S STL-B
113	5063910	2	FTG NUT-16S
114	5064009	2	FTG RDCR -16S-12S
115	5036103	1	FTG TEE STRTHDRUN -4B-4S
117	0112956	1	WIRE ASSEMBLY WIRING BOX
118	0192078	1	WIRING ASSEMBLY, 12KW GENERATOR
201	0112631	1	AIRLINE TO PLATFORM
202	3011005	106 FT	WIRE, 10/3 CONDUCTOR

## 12 kw Generator

## Platform Welder – Aluminum Platform

Item	Part No.	Qty.	Description
1	0083823	1	BRACKET, TOP
2	0083825	1	BRACKET, LOWER
3	0083826	1	SLIDE PAD 2.0 X 8.25 X 1.0
4	0083833	1	WELDMENT, WELDER SUPPORT
5	0083857	1	WELDMENT, BRACKET CABLE STORAGE
6	0083858	1	BRACKET
7	0083862	1	ASSEMBLY, ELECTRODE HOLDER WIRE
8	0083863	1	ASSEMBLY, GROUND WIRE
9	0083985	1	PLACARD, TIPPING HAZARD
10	0084084	1	WELDER ASSEMBLY
11	0150121	2	SLIDE PAD 2.0 X 4.0 X .500
12	302544	2	SNAP PIN W/ LANYARD .375 X 2.25
13	970029	2	BOLT .25-20 .750 GR5
14	972259	4	BOLT FLSKTHD .313-18 1.00
15	972439	2	BOLT CRG .375-16 1.25
16	974659	6	SCREW RDH MACH 10-24 .50
17	984109	2	NUT HEX .375-16
18	986019	2	WASHER FLAT .250
19	986299	2	WASHER FLAT .38
20	987119	2	WASHER LOCK .375
21	5516329	1	LATCH, ADJ DRAW
22	5560004	2	NUT LKG .250-20
23	5560031	5	NUT LKG .313-18
24	5560034	6	NUT LKG 10-24
25	5560372	1	BOLT CRG .313-18 .75 GR5
26	9939464	1	FIRE EXTINGUISHER

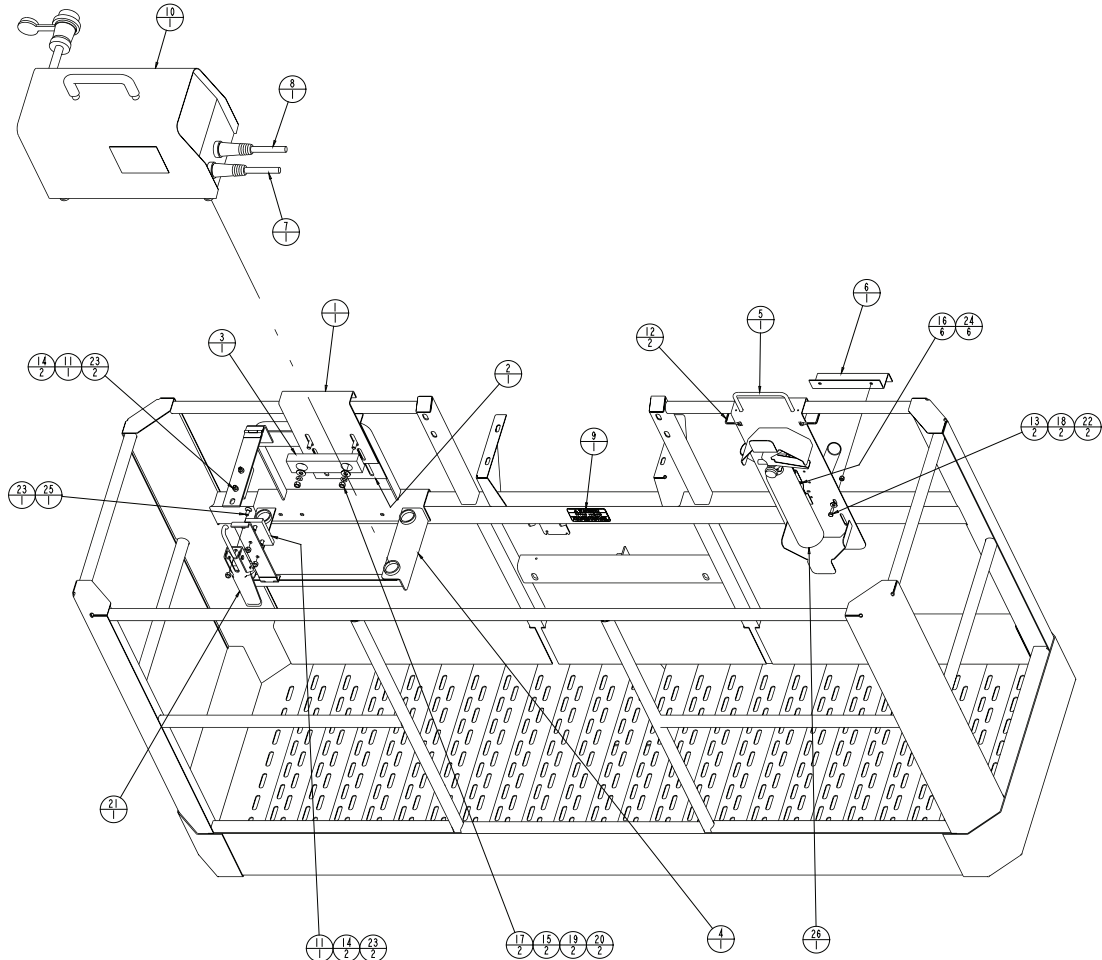

## Platform Welder – Aluminum Platform

0083895



## Platform Welder – Steel Platform

Item	Part No.	Qty.	Description
1	0083823	1	BRACKET, TOP
2	0083825	1	BRACKET, LOWER
3	0083826	1	SLIDE PAD 2.0 X 8.25 X 1.0
4	0083833	1	WELDMENT, WELDER SUPPORT
5	0083857	1	WELDMENT, BRACKET CABLE STORAGE
6	0083858	1	BRACKET
7	0083862	1	ASSEMBLY, ELECTRODE HOLDER WIRE
8	0083863	1	ASSEMBLY, GROUND WIRE
9	0083985	1	PLACARD, TIPPING HAZARD
10	0084084	1	WELDER ASSEMBLY
11	0150121	2	SLIDE PAD 2.0 X 4.0 X .500
12	0161766	4	SLIDE PAD 2.0 X 4.0 X .38
13	302544	2	SNAP PIN W/ LANYARD .375 X 2.25
14	970029	2	BOLT .25-20 .750 GR5
15	972259	4	BOLT FLSKTHD .313-18 1.00
16	972439	2	BOLT CRG .375-16 1.25
17	972489	4	BOLT FLSKTHD .375-16 1.50
18	974659	6	SCREW RDH MACH 10-24 .50
19	984109	2	NUT HEX .375-16
20	986019	2	WASHER FLAT .250
21	986299	2	WASHER FLAT .38
22	987119	2	WASHER LOCK .375
23	5516329	1	LATCH, ADJ DRAW
24	5560004	2	NUT LKG .250-20
25	5560031	5	NUT LKG .313-18
26	5560033	4	NUT LKG .375-16
27	5560034	6	NUT LKG 10-24
28	5560372	1	BOLT CRG .313-18 .75 GR5
29	9939464	1	FIRE EXTINGUISHER

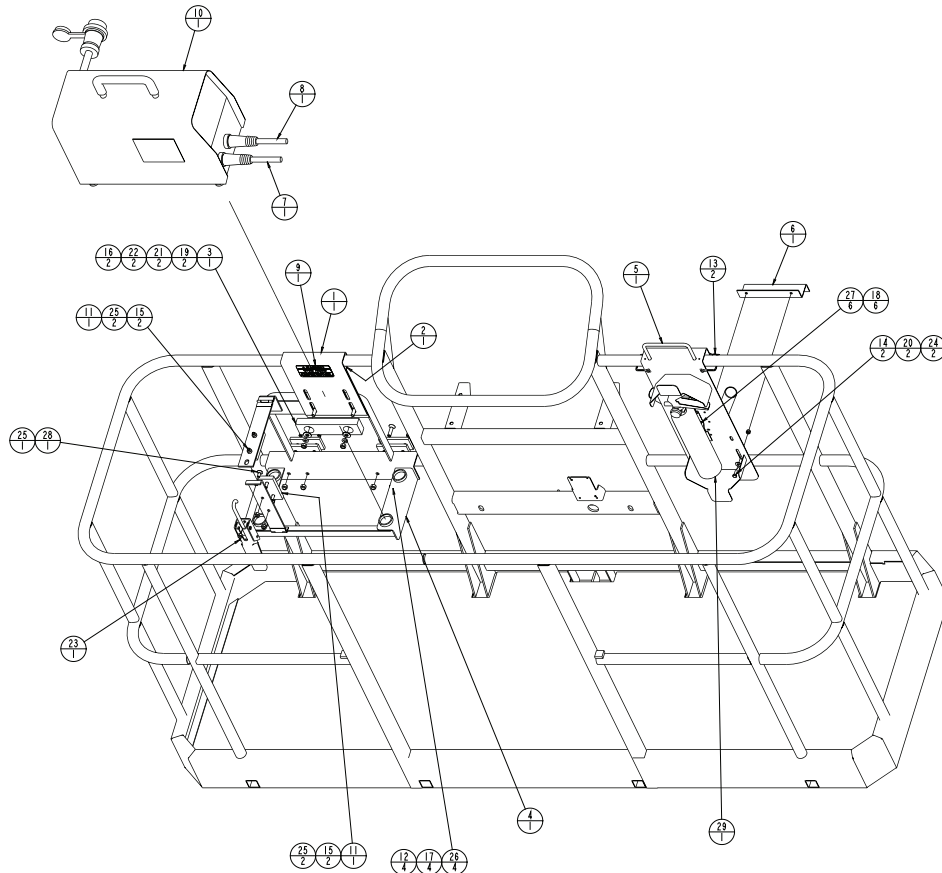

## Platform Welder – Steel Platform

0083999





## Work Lights – Halogen or Incandescent

Item	Part No.	Qty.	Description
1	3064413	2	LIGHT - FLOOD WITH CLAMP - INCANDESCENT
	3067620	2	LIGHT - FLOOD WITH CLAMP - HALOGEN
2	5093019	7	CLAMP
3	3090019	7 FT	FLEXGUARD TUBE
4	5569003	1	GROMMET
5		7	CAPSCREW 1/4-20 X 3/4 LG HEXHD GR5
6	987099	7	LOCK WASHER 1/4 MED
7	986019	7	FLAT WASHER 1/4
8	3040082	3	TERMINAL MALE SLIP-ON FI .250 TAB 16/14 WIRE
9	3011601	7 FT	16 GA. SINGLE CONDUCTOR WIRE X 80" LG
10	3040114	1	CONNECTOR, IN-LINE 16/14 WIRE
11	3044161	1	TERMINAL RING TONGUE INS #10 STUD 16/14 WIRE
12	3040038	1	FUSE HOLDER, IN LINE, BUSS HRK
13	3040039	1	FUSE, 10 AMP (1/4 X 1/4) BUSS AGC
14	3040083	3	TERMINAL FEM SLIP-ON, FI .250 TAB, 16/14 WIRE

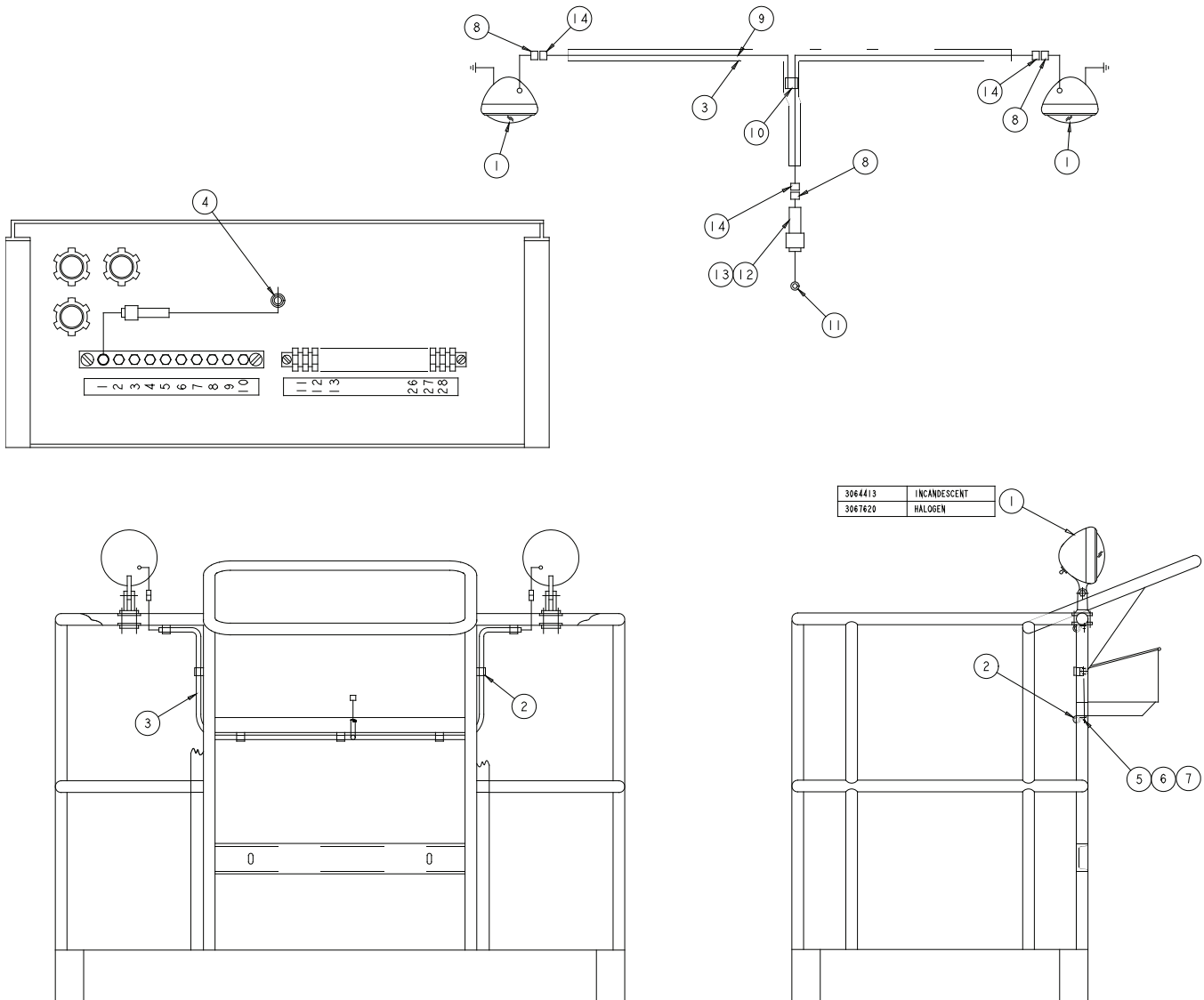

0080768

## Work Lights – Halogen or Incandescent



## Air Inlet Heater – Deutz Engine

Item	Part No.	Qty.	Description
1	7630216	1	AIR INLET HEATER
2	3040506	1	SOLENOID
3	3011001	12	10 GA SINGLE COND WIRE
4	3011601	2	16 GA SINGLE COND WIRE
5	0071568	1	JUMPER WIRE
6	3040268	3	BOOT
7	3070161	2	TERM. 5/16 STUD 8GA
8	0082064	1	PLACARD
9	3090006	1	FLEXGARD TUBE .350 IOD X 7.00 LG
10	3042265	1	TERM #10 STUD 8 GA
11	3044142	1	TERM #6 STUD 16/14 WIRE
12	3040080	1	SWITCH
13	0073781	1	JUMPER WIRE

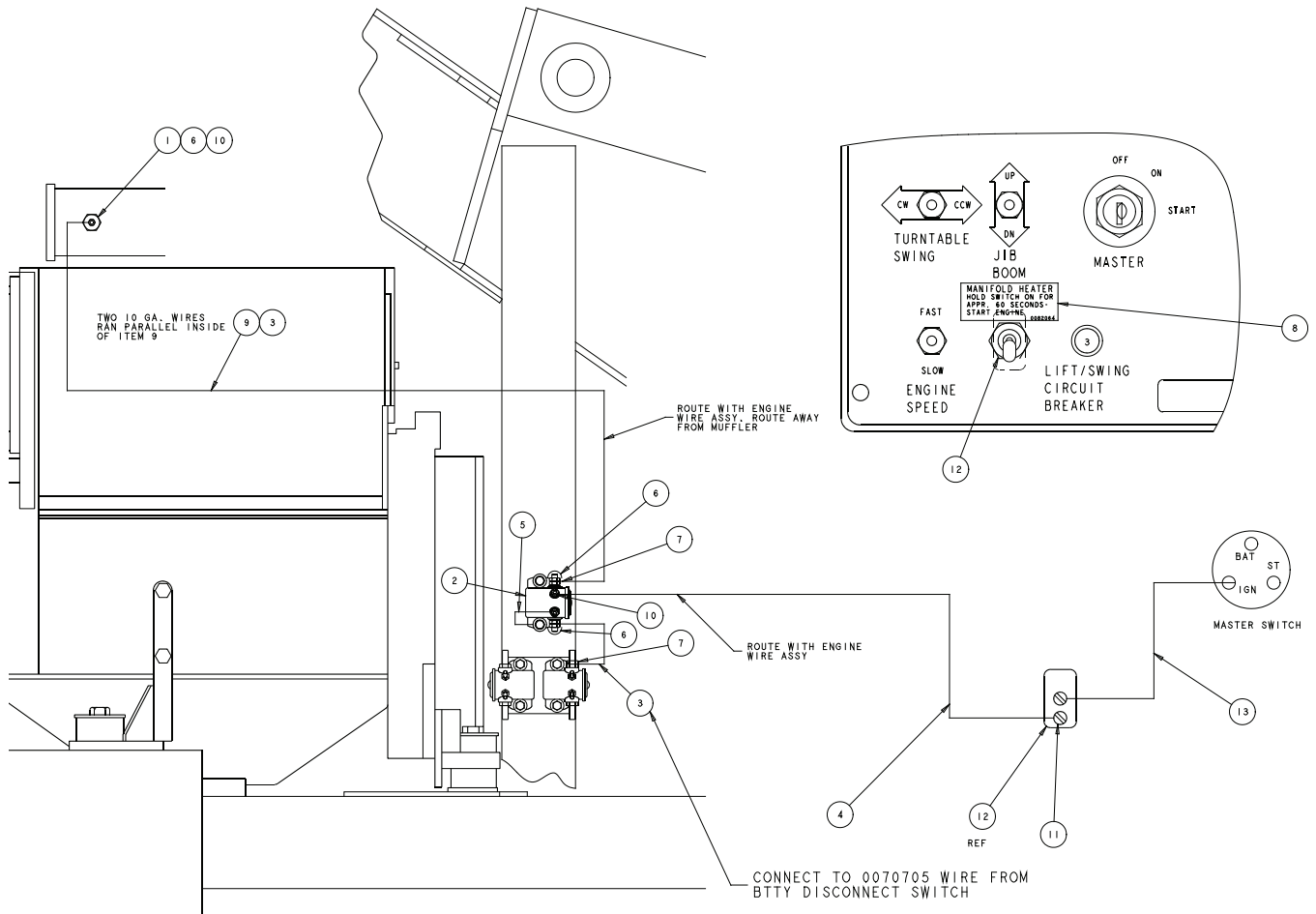

0082058

## Air Inlet Heater – Deutz Engine



## Motion Alarm, All Motion

Item	Part No.	Qty.	Description
1	3040129	1	ALARM
2	3046697	1	TERMINAL FEM1881 16/14 GA
5	3040082	1	TERMINAL .250 MALE SLIP ON FI 16/14 WIRE
6		4	CAPSCREW 1/4-20 X 3/4 LG HH GR5
7	987099	4	WASHER, 1/4 MEDIUM LOCK
8	986019	4	WASHER, 1/4 FLAT
9	3044162	1	TERMINAL 1/4 STUD INS 16/14 WIRE

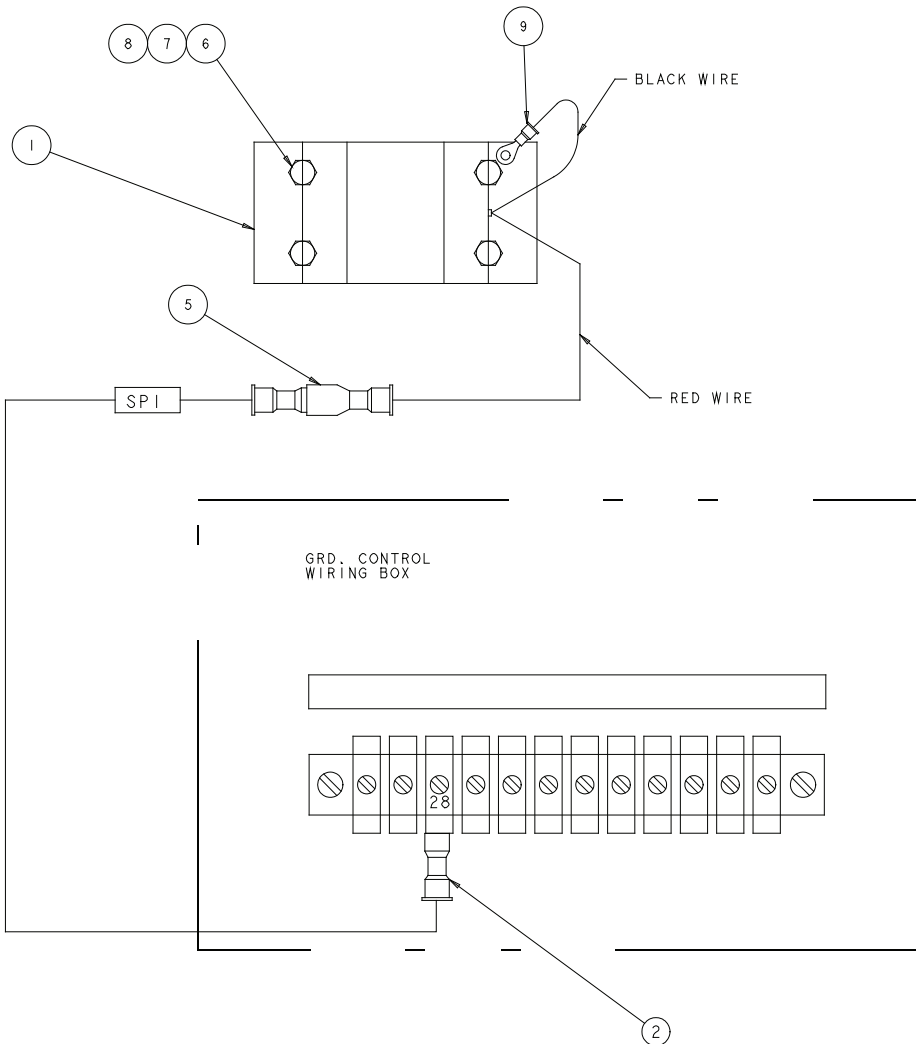
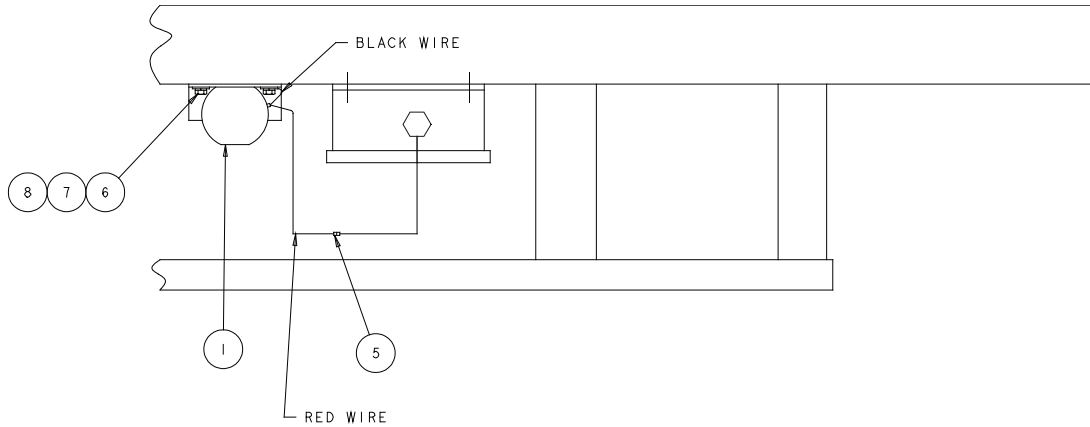

## Motion Alarm, All Motion

0074926



# Airline to Platform

Item	Part No.	Qty.	Description
1	5010024	104 FT	HOSE, AIR 1/2 ID
2	0080759	2	BRACKET
3	5093012	8	CLAMP
4	970049	4	BOLT HH .250-20 X 1.00 LG
5	5560004	4	NUT LKG .250-20
6	5260013	2	HOSE END, 1/2 NPT 1/2 BARBED
7	7714204	2	PLUG 1/2 NPT SOHD
8	5550010	2	CLAMP
9	5093006	2	CLAMP
10	5098339	8.5 FT	SLEEVE, HOSE ABRASION GUARD

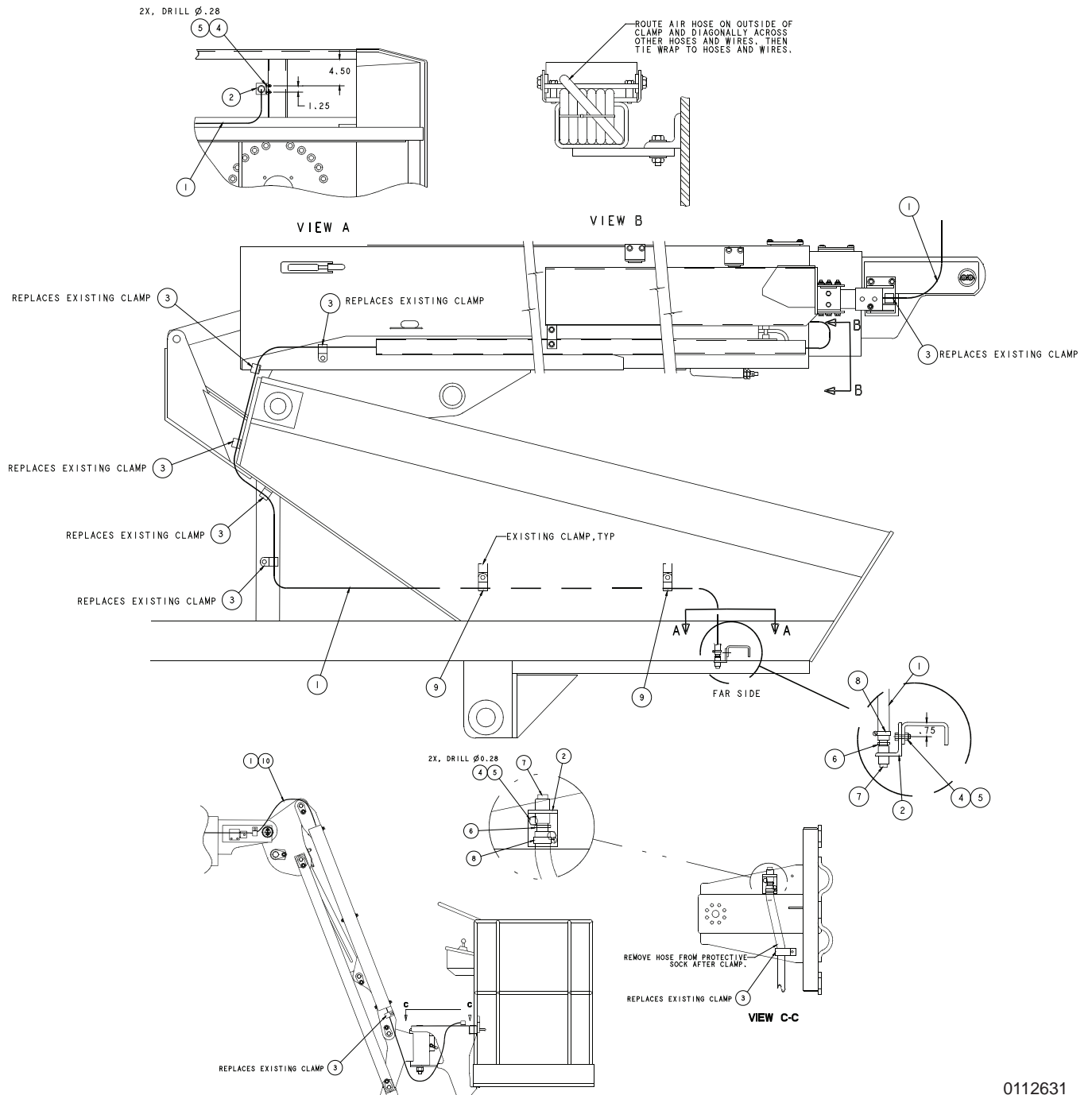

# Airline to Platform

0112631





# Tilt Alarm Light

Item	Part No.	Qty.	Description
1	3069524	1	LIGHT, RED LED 12V .69 DIA MTG
2	0081381	1	DECAL
3	0193234	1	WIRE 16, SPECIAL
4	0073727	1	WIRE 16 R101 FEM1881 16

## PLATFORM CONTROL BOX

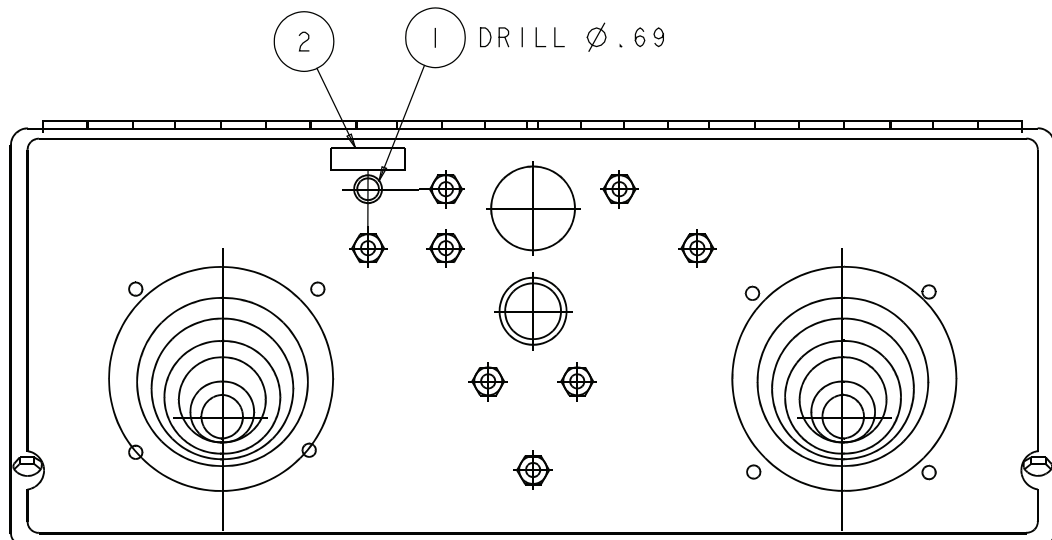
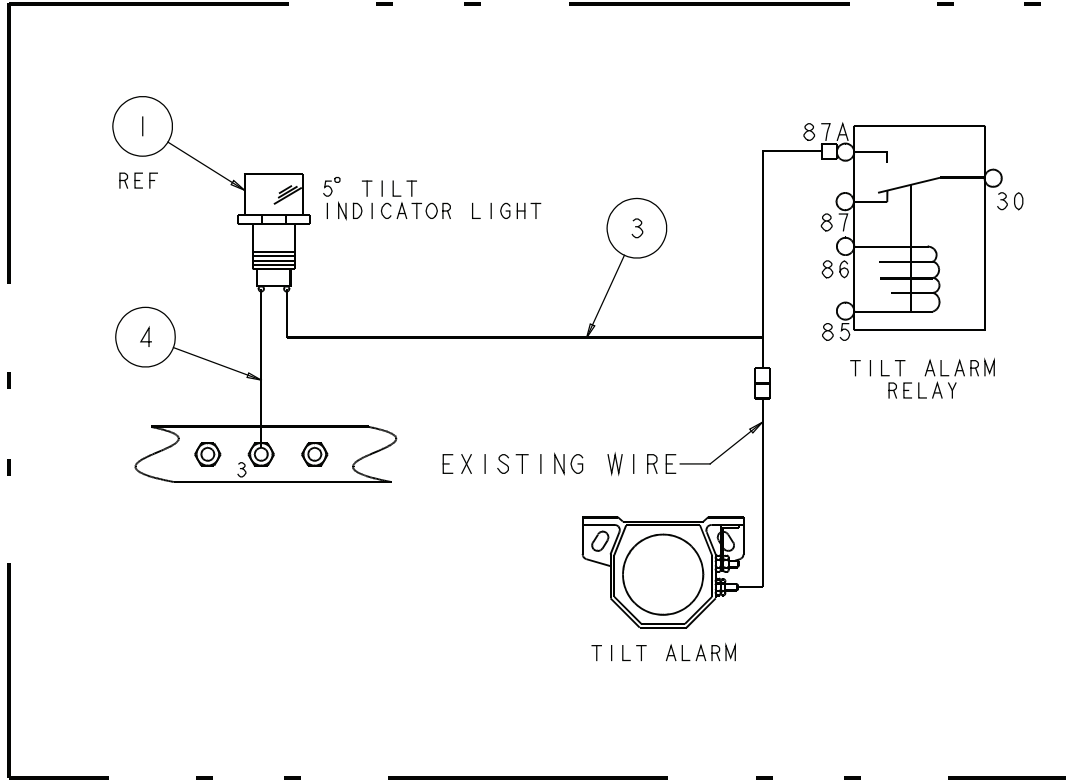

# Tilt Alarm Light

0180109



# Headlights and Taillights

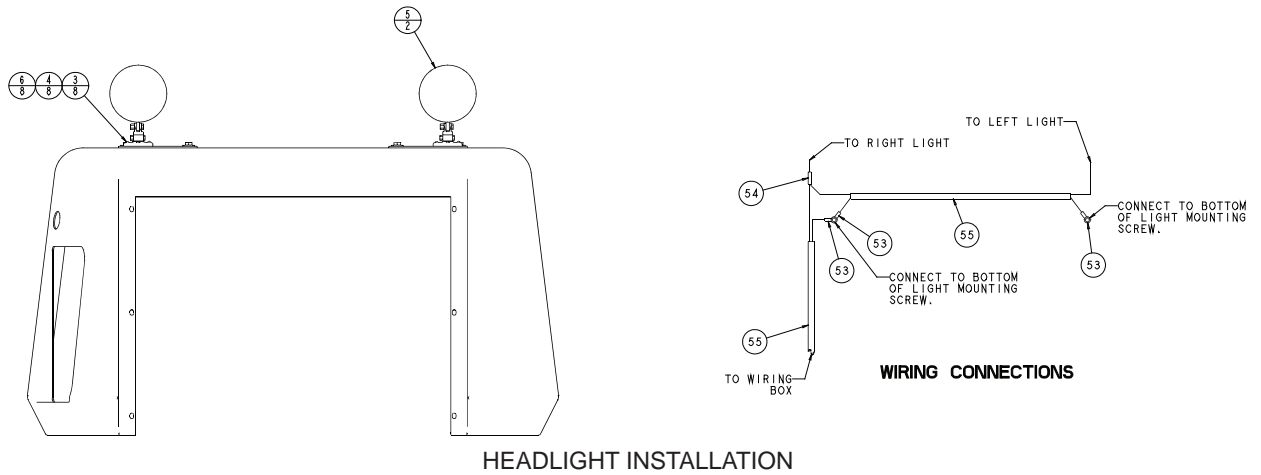
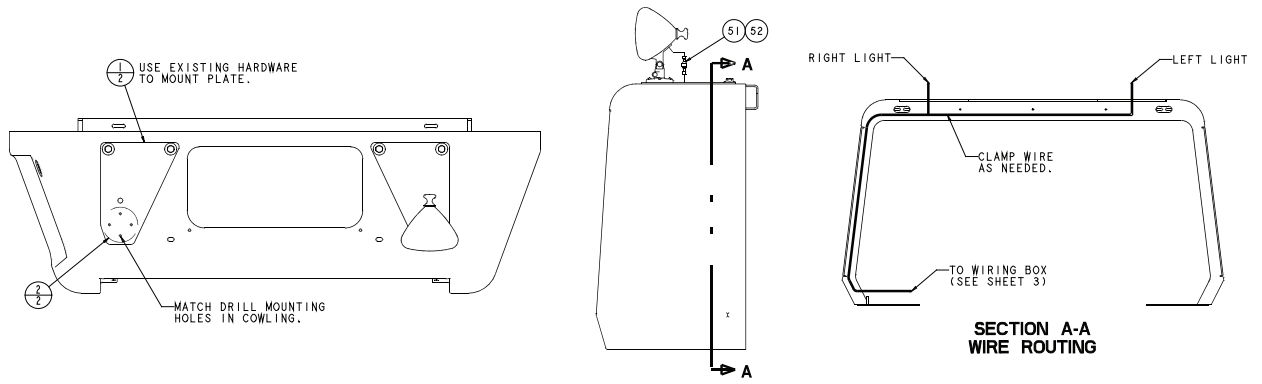

HEADLIGHT INSTALLATION

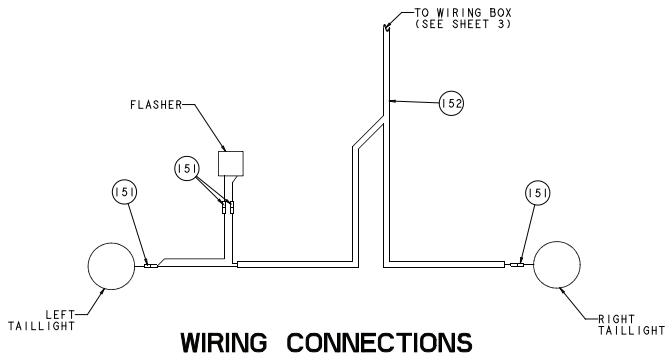

WIRING CONNECTIONS

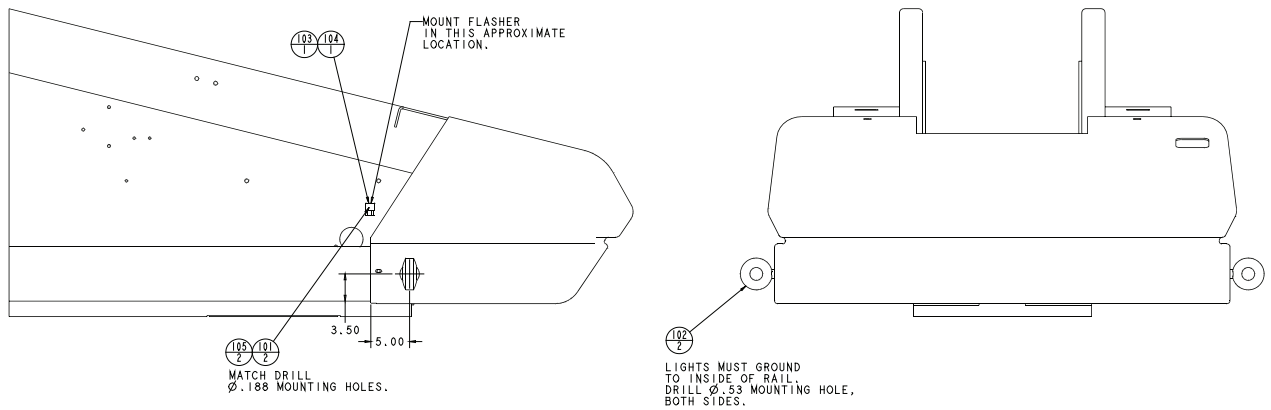

TAILLIGHT INSTALLATION

# Headlights and Taillights

0112630

# Headlights and Taillights

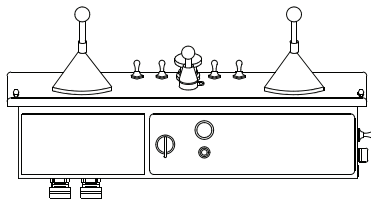
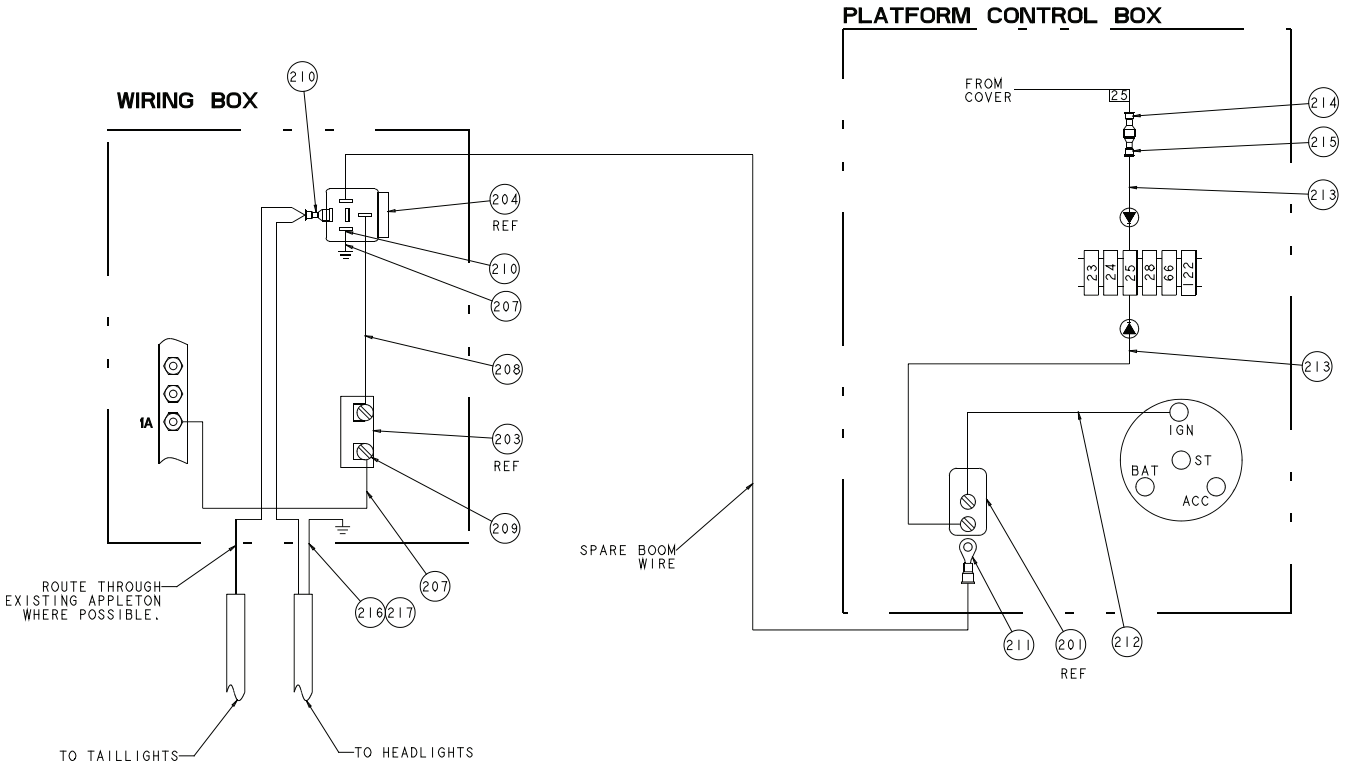

**PLATFORM CONTROL BOX**

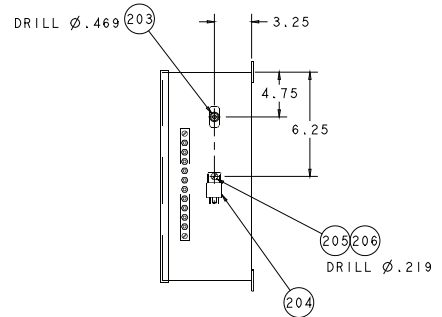
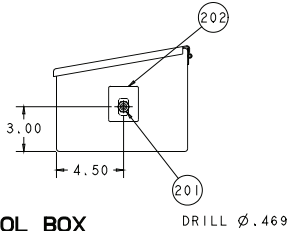

**WIRING BOX  
SIDE VIEW**

# Headlights and Taillights

0112630

## Headlights and Taillights

Item	Part No.	Qty.	Description
1	0112627	2	PLATE, DRIVING LIGHT MTG
2	0112628	2	PLATE, DRIVING LIGHT BACKING
3	974729	8	SCREW RDH MACH 10-24 1.25
4	986009	8	WASHER FLAT 10
5	3064414	2	FLOOD LIGHT
6	5560034	8	NUT LKG 10-24
51	3040083	2	TERMINAL FEM250FI 16/14
52	3040082	2	TERMINAL MALE250FI 16/14
53	3044161	3	TERMINAL R101 16/14
54	3044071	1	TERMINAL BUTT CONNECTOR INSUL 16/14
55	3011403	10.25 FT	CABLE 14 GA /3 CONDUCTOR WIRE
101	974449	2	SCREW EDH MACHINE 8/32 .75
102	3060017	2	TURN SIGNAL LIGHT DBL FACE LENS
103	3060018	1	FLASHER BASE
104	3060019	1	FLASHER
105	5560198	2	NUT LKG 8-32
151	3040086	4	TERMINAL FEM250FI 16/14
152	0111669	1	WIRE ASSEMBLY TAIL LIGHT
201	3020013	1	SWITCH TGL SPST ON OFF SEALED
202	0181376	1	PLAC LIGHTS ON/OFF SW
203	3040068	1	CIRCUIT BREAKER 20 AMP
204	3040469	1	RELAY SPDT 12V 30 AMP
205	5560609	1	SCREW TRHD 10-24 .50
206	5560034	1	NUT LKG 10-24
207	0072293	2	WIRE 12 R101 NONE 17
208	0181187	1	WIRE 12 R61 FEM250FI 6
209	3044852	1	TERMINAL R61 12/10
210	3040065	2	TERMINAL FEM250FI 12/10
211	3044142	1	TERMINAL R61 22/18
212	0073781	1	WIRE 16 R101 R61 6
213	0073250	2	WIRE 18 R101 FEM1881 17 DIO
214	3040082	1	TERMINAL MALE250FI 16/14
215	3044599	1	TERMINAL FEM2501 22/18
216	3040115	1	CONNECTOR .500 .375-.500
217	3040070	1	NUT LKG .500 HUB

## Headlights and Taillights



# Walk-through Gate

Item	Part No.	Qty.	Description
1	0071837	1	TORSION SPRING
2	0075469	1	WELDMENT, SWING GATE BRACKET
3	0075471	1	WELDMENT, END SWING GATE
4	0075479	1	BRACKET, LATCH MOUNTING
5	300491	1	LATCH RH ROTARY LOCK
6	302555	1	KNOB, BALL .75 DIA .250-20
7	970009	1	BOLT HEXHD .25-20 .500 GR5
8	970239	9	BOLT HEXHD .313-18 .750 GR5
9	970269	3	BOLT HEXHD .313-18 1.25 GR5
10	986269	9	WASHER FLAT .313
11	986359	2	WASHER FLAT .500
12	987109	9	WASHER LOCK .313
13	2572007	4	BEARING
14	3040016	2	HOLE PLUG 1.00
15	5560031	3	NUT LKG .313-18
16	5560039	1	NUT LKG .500-13
17	5560337	+	NUTSERT .313-18 .027-.150
18	5563044	1	BOLT SHLDR .500 1.75
19	5563047	1	BOLT HEXHD .500-13 10.00

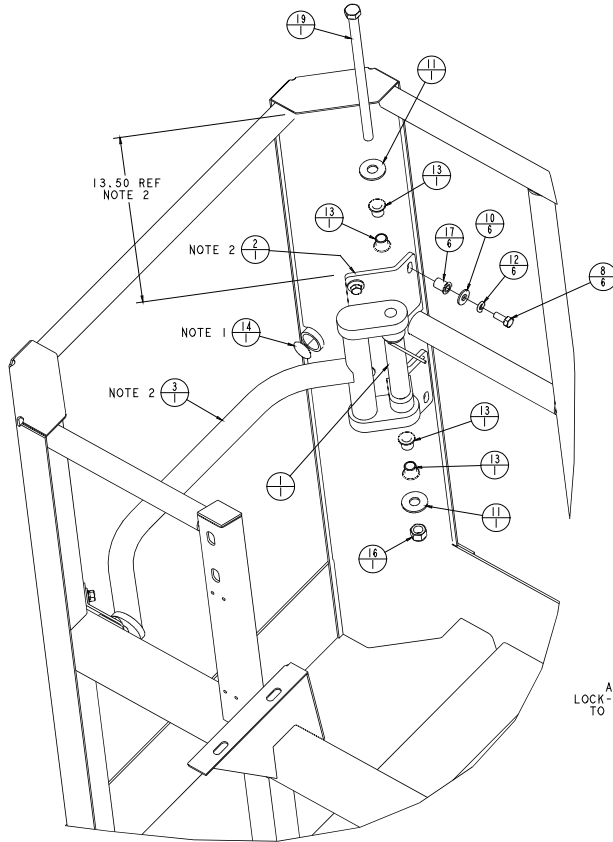

**HINGE INSTALLATION**

- NOTES:**
- CUT OUT EXISTING MID RAIL AND CAP. CUT ENDS WITH 3040016 HOLE PLUGS. SPREAD TANGS OUT AS REQD FOR SECURE FIT.
  - SUB-ASSEMBLE 0075471 GATE WLDMT AND 0075469 BRKT WLDMT. POSITION SO THAT SWING GATE IS .25" BELOW CENTERLINE OF PLATFORM MIDRAIL. VERIFY THAT SHOULDER BOLT HEAD PASSES UNDER FRONT RAIL OF PLATFORM. MARK AND MATCH DRILL Ø.531 HOLES FOR NUTSERTS. TYP 6 PLCS.
  - SUB-ASSEMBLE 0075479 BRKT AND 300491 LATCH. POSITION SO THAT STRIKER BOLT ON SWING GATE IS CENTERED IN LATCH. MARK AND MATCH DRILL Ø.531 HOLES FOR NUTSERTS. TYP 3 PLCS.

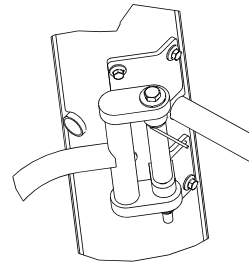

**ASSEMBLED HINGE, REF**

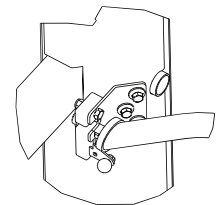

**ASSEMBLED LATCH, REF**

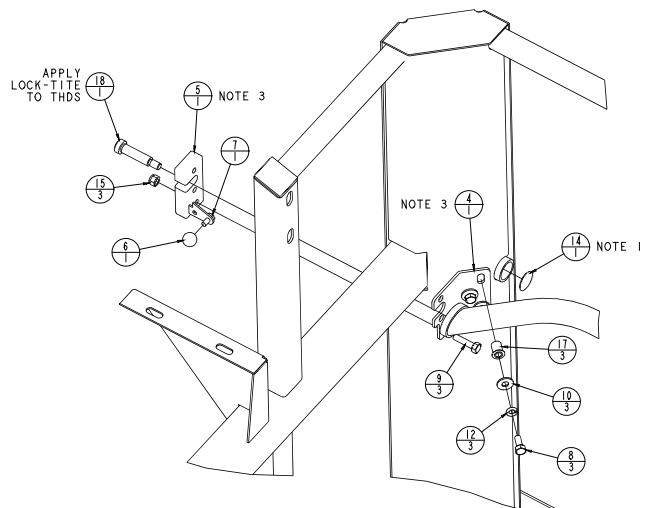

**LATCH INSTALLATION**

0075478

# Walk-through Gate





# Gravity Gate

Item	Part No.	Qty.	Description
1	0071953	2	SPACER
2	0072563	2	BAR, PLATFORM WELDMENT
3	0075502	1	WELDMENT, GRAVITY GATE - SIDE
4	0150509	2	ROLLER, STEEL GRAVITY GATE
5	0181485	2	END CAP
6	970539	2	BOLT HEXHD .375-16 2.75
7	5560033	2	NUT LKG .375-16

**NOTES:**

1. CUT OUT EXISTING MID RAIL, GRIND OFF WELD AND REMAINDER OF TUBE. INSTALL TUBE END PLUGS. CONTINUOUS WELD AND GRIND SMOOTH. MAY BE INSTALLED ON EITHER END OF PLATFORM.
2. CENTER ON HORIZONTAL TUBE APPROX .188 AWAY FROM VERTICAL TUBE. CONTINUOUS WELD ON 3 SIDES.

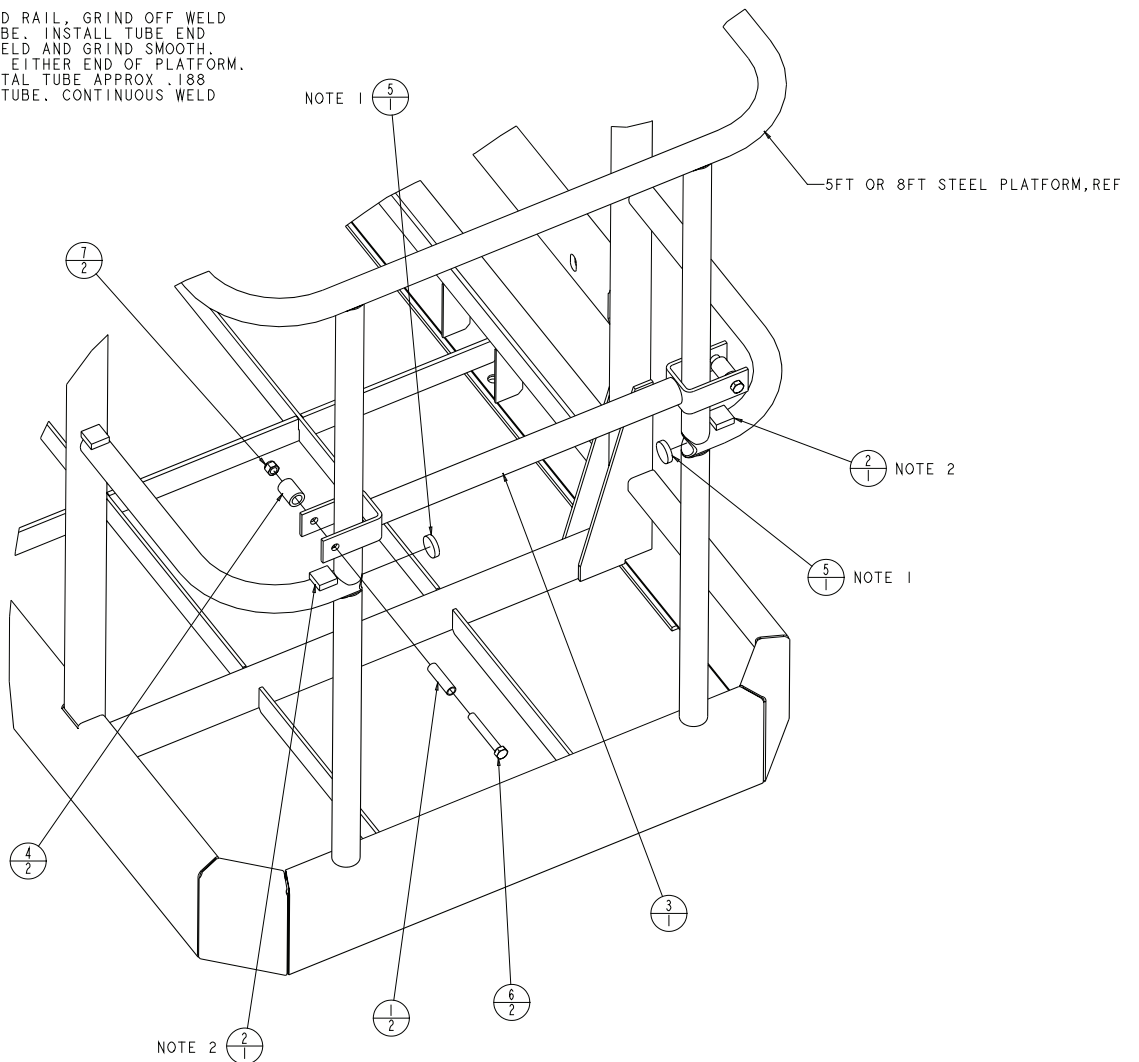

0075500

# Gravity Gate



## Spark Arrestor – Deutz Engines Only

Item	Part No.	Qty.	Description
1	0075102	1	TAILPIPE, SPARK ARRESTOR
2	0112933	1	BRACKET, TAILPIPE SUPPORT
3	986359	2	WASHER FLAT .500
4	5550005	1	EXHAUST CLAMP
5	5560207	2	BOLT 14MM-2.00P 30MM GR8.8 DH
6	5560377	2	WASHER LOCK M14
7	7630795	1	MUFFLER, ADAPTER
8	7630796	2	DIFFUSER DISC SUPERTRAP (12 PACK)

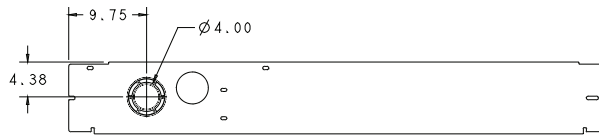

LH TOP COWL DRILLING

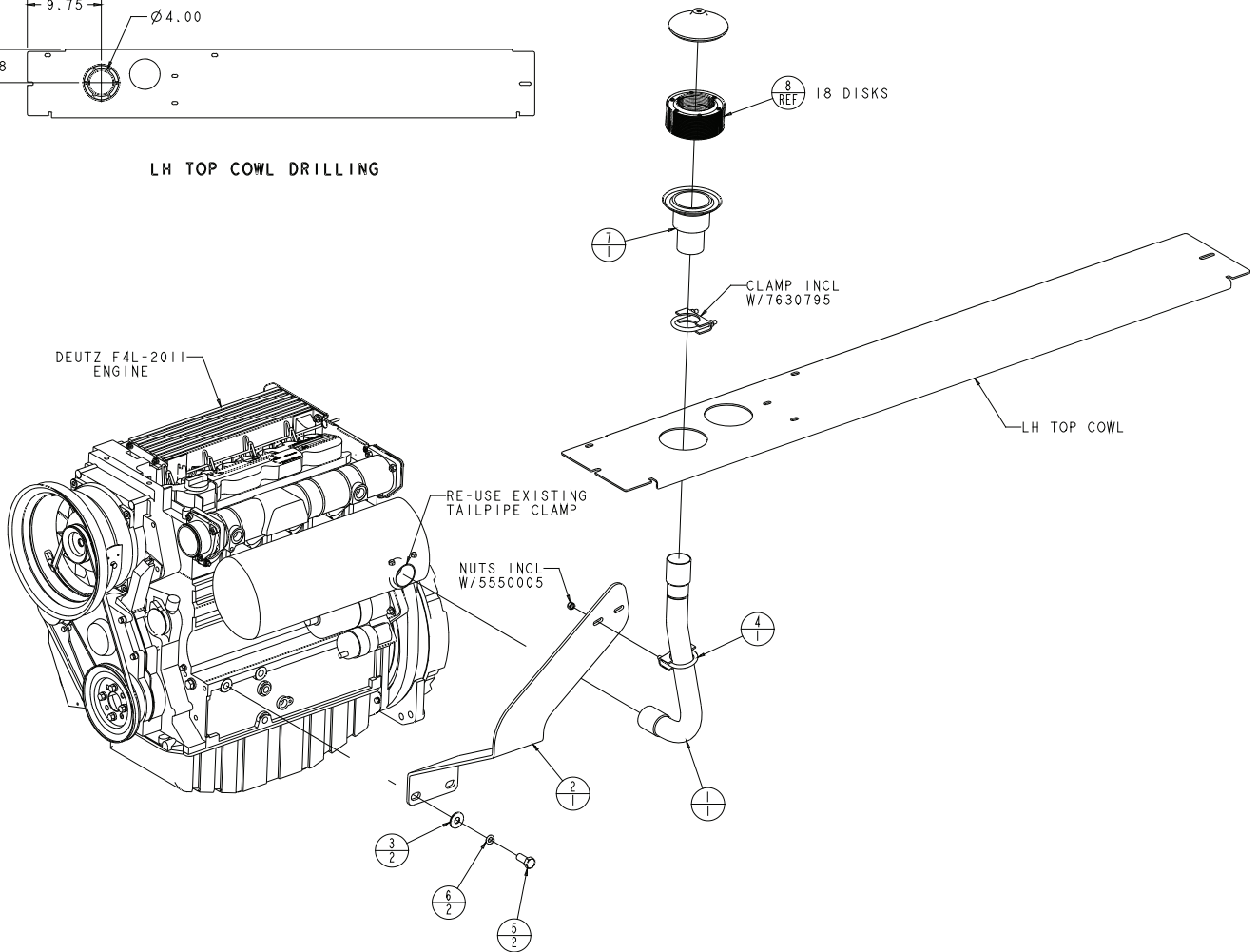

0112932

## Spark Arrestor – Deutz Engines Only



## Dual Flashing Light, Amber or Red

Item	Part No.	Qty.	Description
1	3060083	2	WARNING LIGHT, AMBER LENS
	3060084	2	WARNING LIGHT, RED LENS
	8160047	1	REPLACEMENT BULB
2	3011601	1	WIRE, 16 GAUGE SINGLE CONDUCTOR X 240 INCH LONG
3	3090019	1	FLEXGARD TUBE, 240 INCH LONG
4	5093019	6	CLAMP
5	3040046	2	TERMINAL .250 TAB MALE SLIP-ON FULLY INSULATED 22/18 WIRE
6	3040083	2	TERMINAL .250 TAB FEMALE FULLY INSULATED 16/14 WIRE
7	3044146	2	TERMINAL #10 STUD INSULATED 22/18 WIRE
8	3044161	2	TERMINAL #10 STUD INSULATED 16/14 WIRE
9	970029	6	CAPSCREW 1/4-20 X 3/4 INCH LONG HEX HEAD GRADE 5
10	986019	6	WASHER 1/4 MEDIUM FLAT
11	987099	6	WASHER 1/4 MEDIUM LOCK

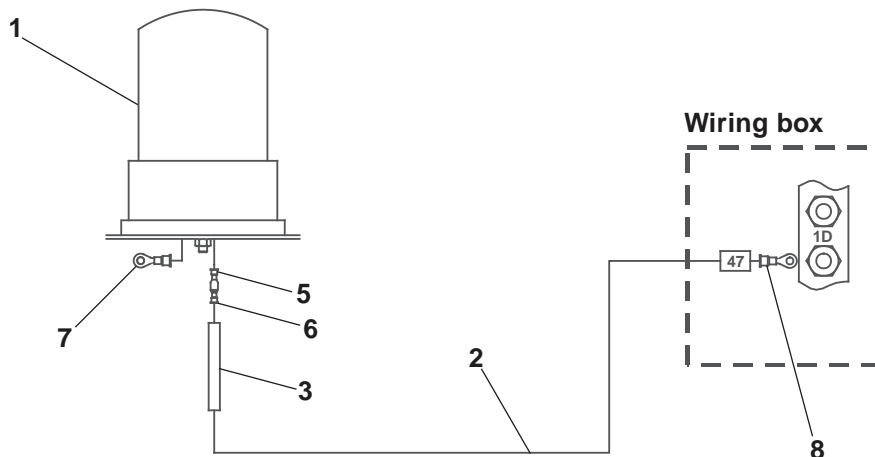
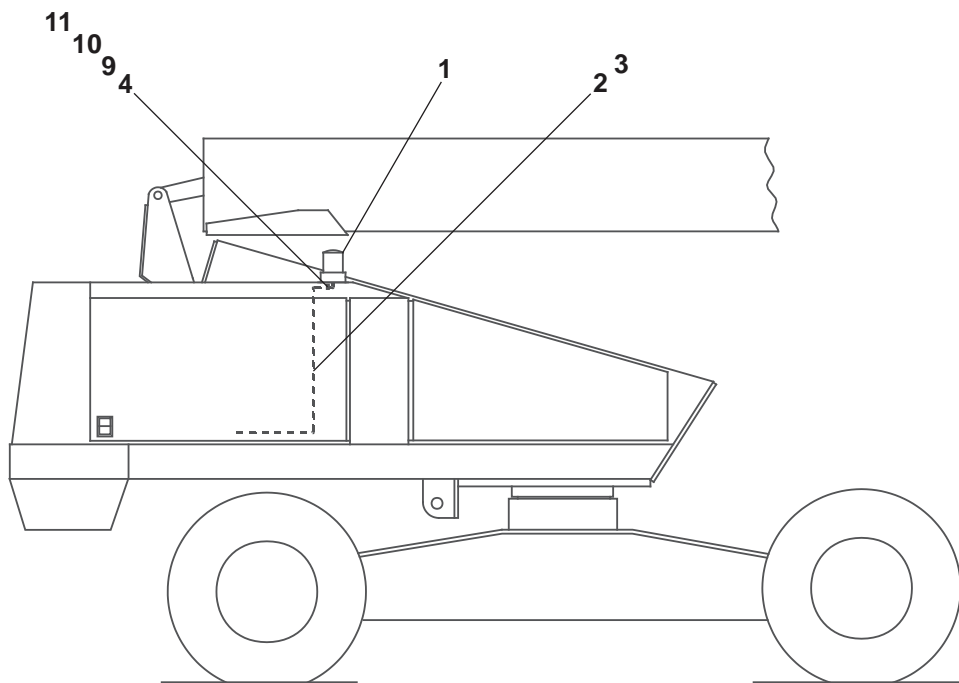

AW0112142

## Dual Flashing Light, Amber or Red



## Drive Motion Alarm

Item	Part No.	Qty.	Description
1	3040129	1	MOTION WARNING ALARM, STANDARD
	3040462	1	MOTION WARNING ALARM, UL APPROVED
2	0081422	1	MOUNT ANGLE - (USED WITH UL APPROVED WARNING ALARM ONLY)
3	0073642	1	JUMPER WIRE
4	0073071	1	JUMPER WIRE
5	3040046	2	TERMINAL .250 TAB MALE SLIP-ON FULLY INSULATED 22/18 WIRE
6	3040082	1	TERMINAL .250 TAB MALE FULLY INSULATED 16/14 WIRE
7	970029	4	CAPSCREW 1/4-20 X 3/4 INCH LONG HEX HEAD GRADE 5
8	987099	4	WASHER 1/4 MEDIUM LOCK
9	986019	4	WASHER 1/4 MEDIUM FLAT
10	3044162	1	TERMINAL 1/4 STUD INSULATED 16/14 WIRE

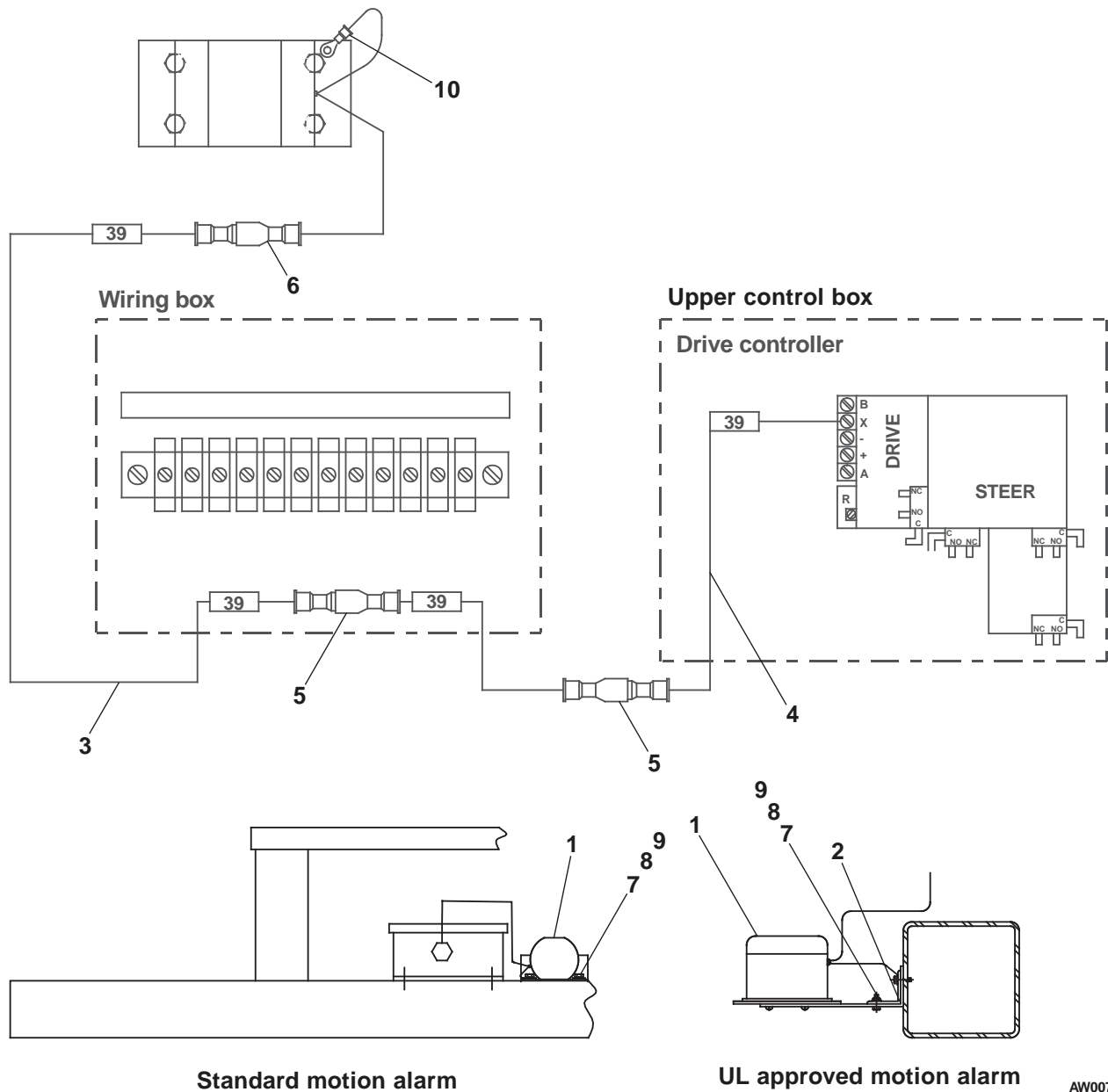

AW0073066

## Drive Motion Alarm





## Platform Control Cover

Item	Part No.	Qty.	Description
1	0073076	1	UPPER CONTROL BOX COVER, STANDARD
	0074782	1	UPPER CONTROL BOX COVER, FIRE RESISTANT
2	5560657	3	POP RIVET 1/8 INCH ALUMINUM #RVT-AD48 ABS
3	5560656	3	POP RIVET 1/8 INCH ALUMINUM #RVT-AD46 ABS

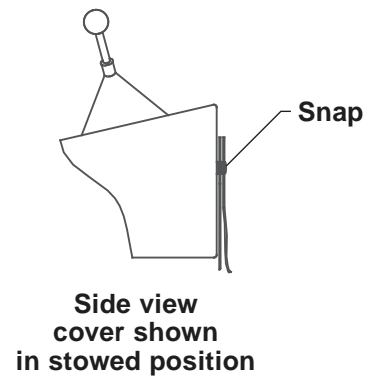
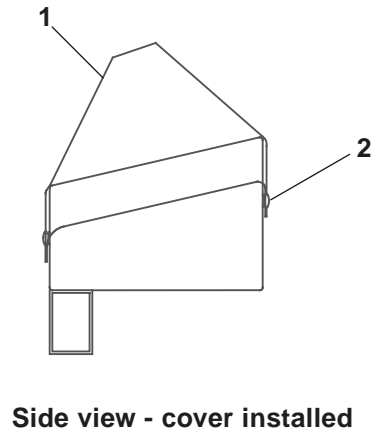
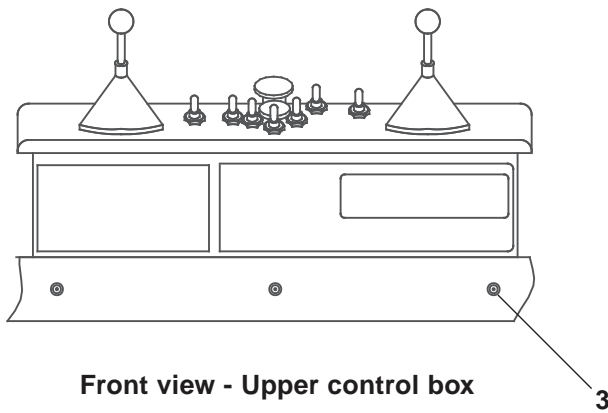

AW0071654

## Platform Control Cover



## Isolation Valve

Item	Part No.	Qty.	Description
1	6010495	1	BALL VALVE, 3/4 NPT
2	6010498	1	BALL VALVE, 1-1/2 NPT
3	7740014	1	CLOSE NIPPLE 1/2 NPT
4	7740110	1	CLOSE NIPPLE 1-1/4 NPT
5	7720604	2	REDUCER BUSHING 3/4 X 1/2
6	7721210	1	REDUCER BUSHING 1-1/2 X 1-1/4
7	5031008	1	STREET ELBOW 90° 1-1/2 NPT

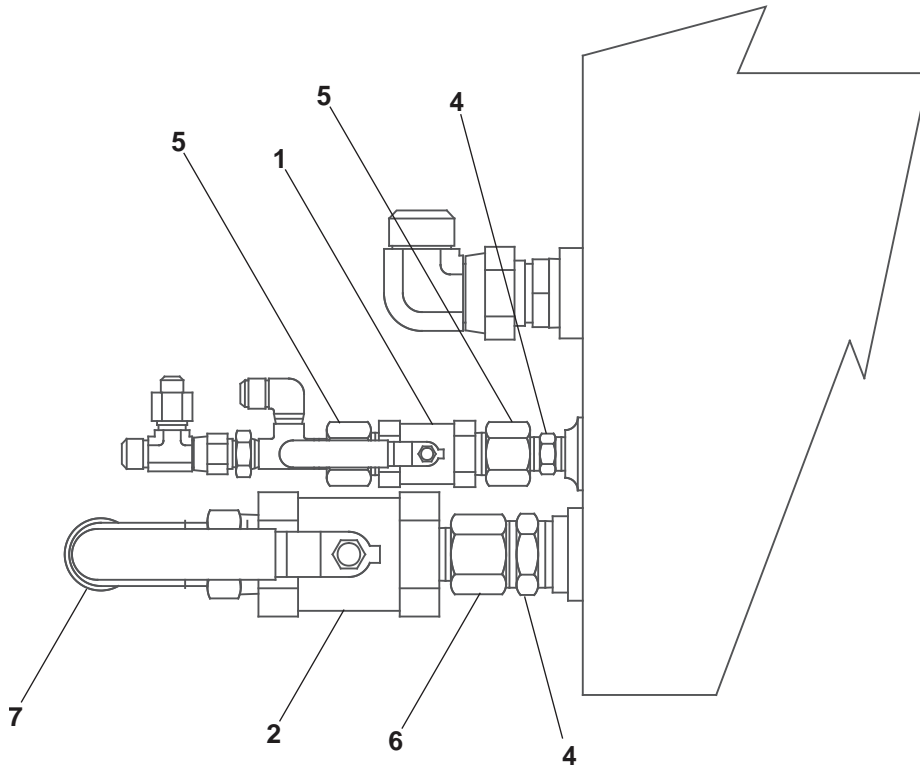

AW011022B

## Isolation Valve



# Sandblast Kit

Item	Part No.	Qty.	Description
1	0110786	1	TURNTABLE COVER WELDMENT
2	0110762	1	BELLOWS, LIFT CYLINDER
3	0071998	2	BELLOWS, LEVEL CYLINDER
4	5550030	2	CLP WORM DRIVE
5	5550060	3	CLP WORM DRIVE
6	5550152	1	CLP WORM DRIVE
7	970449	4	BOLT HEXHD .38-16 X .75 LG GR5
8	987119	4	WASHER .38 LOCK
101	0112619	4	BELLOWS, MASTER LEVEL CYLINDER – TB85J ONLY
102	5560105	2	CLP WORM DRIVE – TB85J ONLY
103	5560020	1	CLP WORM DRIVE – TB85J ONLY
104	0112621	1	BELLOWS, 5' JIB CYLINDER – TB85J ONLY
105	5560060	1	CLP WORM DRIVE – TB85J ONLY

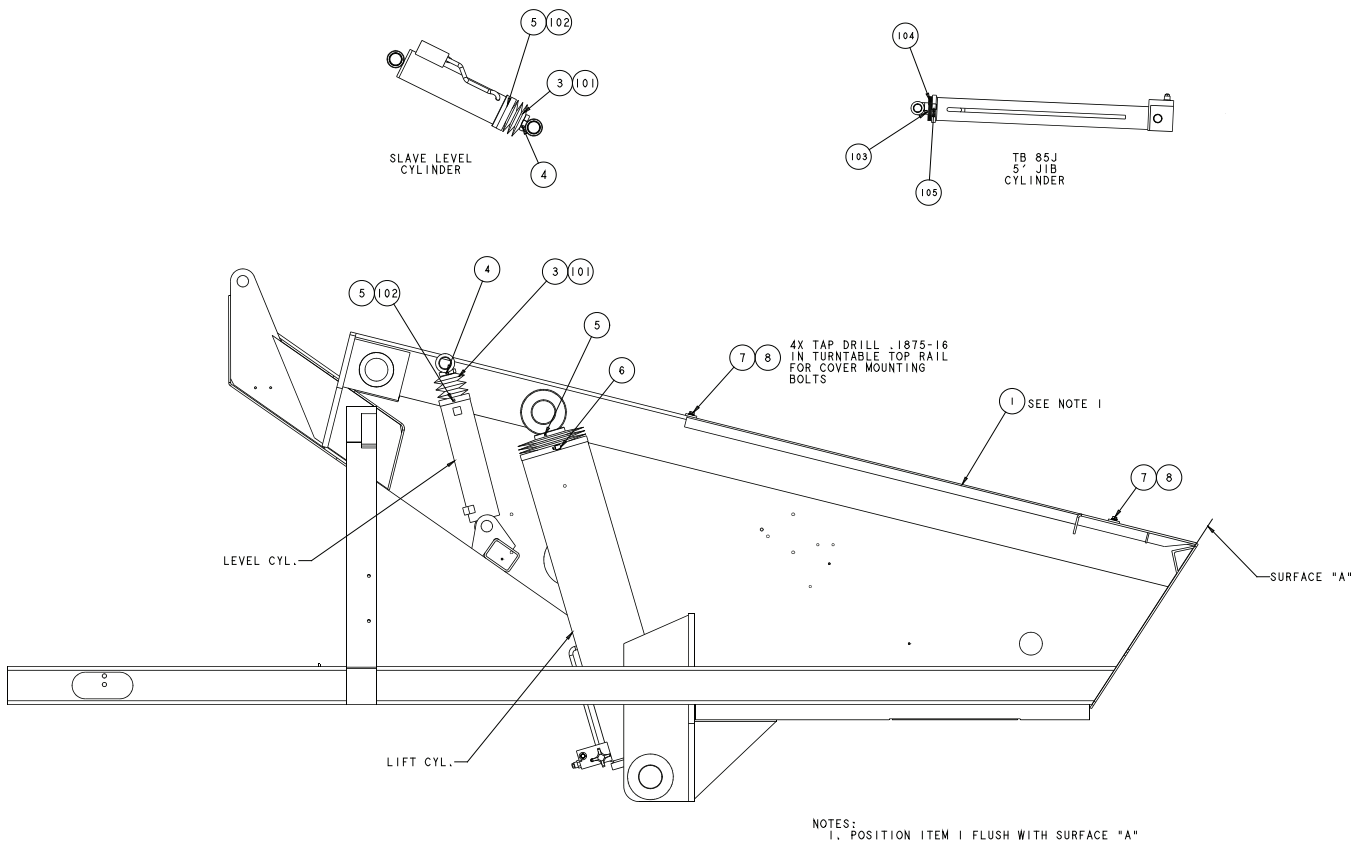

A11067B

# Sandblast Kit



# Hydraulic Warm-Up

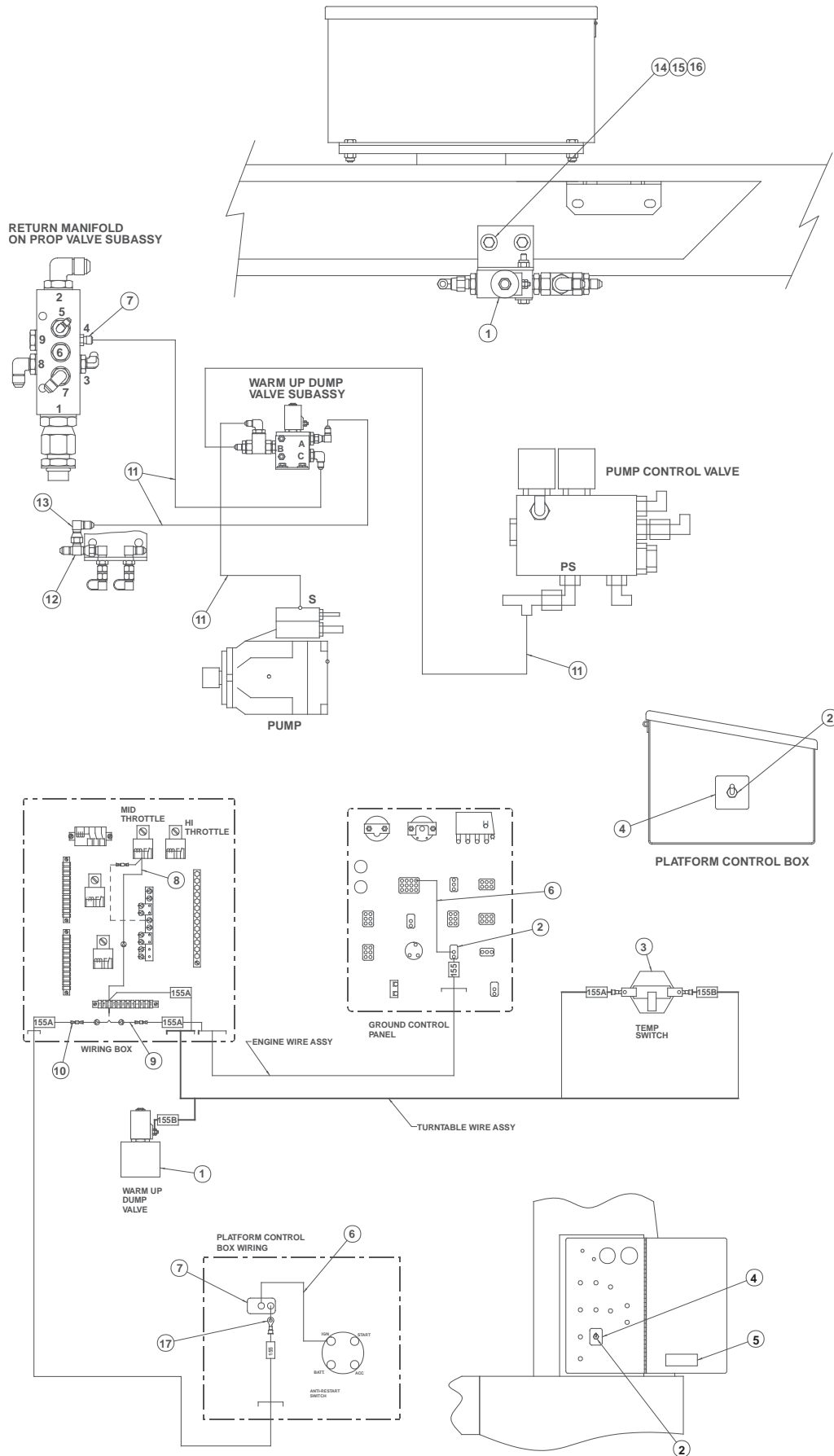

AW011021A

# Hydraulic Warm-Up

## Hydraulic Warm-Up

Item	Part No.	Qty.	Description
1	0082053	1	HYDRAULIC WARM-UP VALVE
2	3020013	2	SWITCH, TOGGLE
3	3020078	1	TEMPERATURE SWITCH
4	0071792	1	PLACARD, WARM-UP SWITCH
5	0071793	1	DECAL, HYDRAULIC WARM-UP INSTRUCTIONS
6	0071844	2	JUMPER WIRE
7	5065705	1	STRAIGHT THREAD ADAPTER
8	0181398	1	DIODE JUMPER WIRE
9	0181285	1	DIODE JUMPER WIRE
10	3040047	1	TERMINAL .250 TAB FEMALE SLIP-ON FULLY INSULATED 22/18 WIRE
11	0020290	4	1/4 INCH HYDRAULIC HOSE
12	5036703	1	SWIVEL NUT RUN TEE
13	5037003	1	SWIVEL NUT 90° ELBOW
14	970029	2	CAPSCREW 1/4-20 X 3/4 INCH LONG HEX HEAD GRADE 5
15	986019	2	WASHER 1/4 MEDIUM FLAT
16	987099	2	WASHER 1/4 MEDIUM LOCK
17	3044142	1	TERMINAL #6 STUD INSULATED 22/18 WIRE

## Hydraulic Warm-Up



# Four Halogen Lights

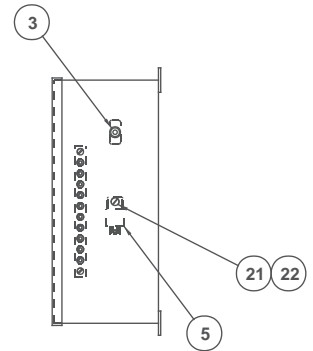
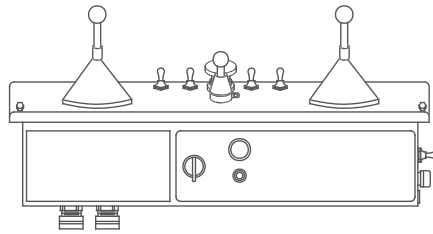
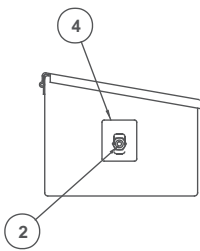
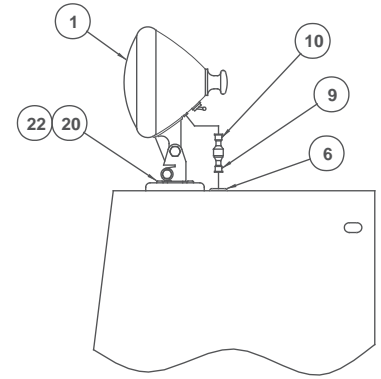
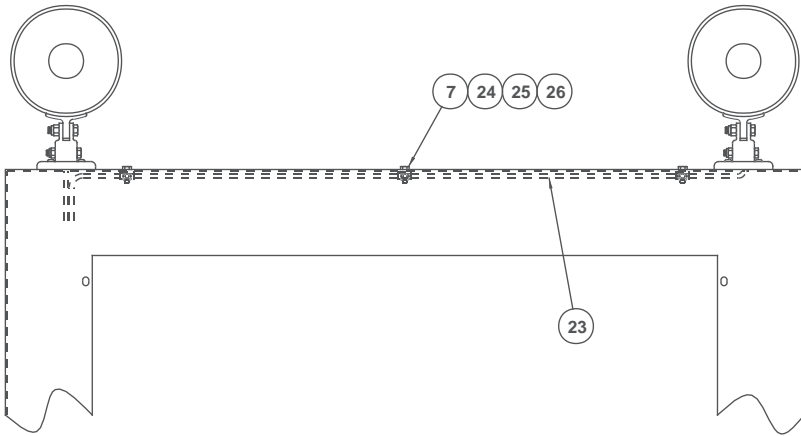

PLATFORM CONTROL BOX  
FRONT VIEW

WIRING BOX  
SIDE VIEW

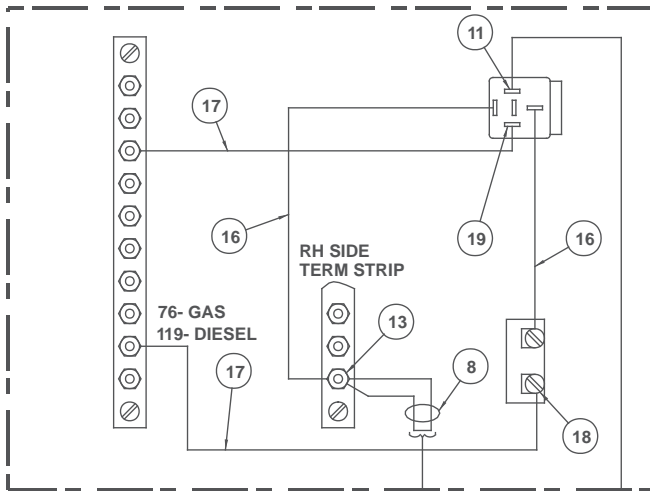

ROUTE THRU ENGINE WIRE CONNECTOR.  
USE ITEM 7 AS REQD TO SECURE WIRES.  
USE ITEM 23 TO GUARD WIRE FROM BEING  
DAMAGED.

SPARE BOOM  
WIRE

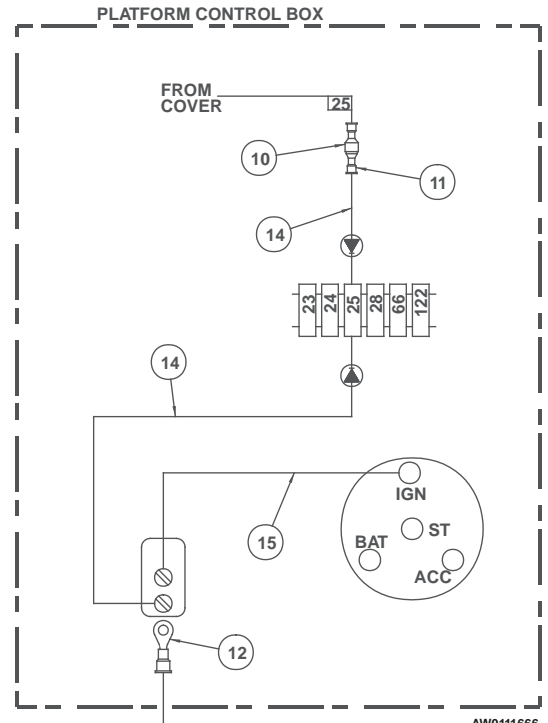

# Four Halogen Lights

AW011666

## Four Halogen Lights

Item	Part No.	Qty.	Description
1	3067620	4	LIGHT, HALOGEN
2	3020013	1	SWITCH, TOGGLE
3	3040068	1	CIRCUIT BREAKER, 20 AMP CAPACITY
4	0181376	1	PLACARD, LIGHT SWITCH
5	3040469	1	RELAY, 12 VOLT DC
6	5569003	2	GROMMET
7	5093019	4	CLAMP
8	3011601	1	WIRE, 16 GAUGE SINGLE CONDUCTOR X 120 INCH LONG
9	3040083	2	TERMINAL .250 TAB FEMALE FULLY INSULATED 16/14 WIRE
10	3040082	3	TERMINAL .250 TAB MALE FULLY INSULATED 16/14 WIRE
11	3044599	2	TERMINAL .250 TAB FEMALE SLIP-ON INSULATED 22/18 WIRE
12	3044142	1	TERMINAL #6 STUD INSULATED 22/18 WIRE
13	3044161	2	TERMINAL #10 STUD INSULATED 16/14 WIRE
14	0073250	2	JUMPER WIRE
15	0073781	1	JUMPER WIRE
16	0181187	2	JUMPER WIRE
17	0072293	2	JUMPER WIRE
18	3044852	1	TERMINAL RING TONGUE INSULATED 12/10 WIRE
19	3040065	1	TERMINAL .250 TAB FEMALE SLIP-ON FULLY INSULATED 12/10 WIRE
20	5560692	8	MACHINE SCREW #10-24 X 1 INCH LONG PAN HEAD
21	5560609	1	MACHINE SCREW #10-24 X 1/2 INCH LONG TRUSS HEAD
22	5560034	8	NUT #10-24 SELF LOCKING
23	3090019	1	FLEXGARD TUBE, 120 INCH LONG
24	970029	4	CAPSCREW 1/4-20 X 3/4 INCH LONG HEX HEAD GRADE 5
25	986019	4	WASHER 1/4 MEDIUM FLAT
26	5560004	4	NUT 1/4-20 SELF LOCKING

## Four Halogen Lights

# *Maintenance*

TB80

TB85J



 **snorkel**



---

## Maintenance

Every person who maintains, inspects, tests or repairs the aerial platform must be qualified to do so. Maintenance functions must be performed by maintenance personnel who are qualified to work on the aerial platform.

### Caution

**Welding current can be very intense. Damage to electronic components can result. Connect the ground clamp as close as possible to the area being welded. Disconnect the battery cables and any microprocessors and engine control modules before welding on the machine.**

If it becomes necessary to weld aerial platform components as a method of repair, take all precautions to prevent damage to electronic circuitry and devices on the machine. This includes, but may not be limited to, disconnecting battery cables and electronic devices.

Do not modify this aerial platform without prior written consent of the Snorkel Engineering Department. Modification may void the warranty, adversely affect stability or affect the operational characteristics of the aerial platform.

### Maintenance Schedules

Snorkel has established a preventative maintenance schedule to detect any defective, damaged or improperly secured parts and provide information regarding lubrication and other minor maintenance items.

This schedule includes the following:

- Daily Prestart Inspection
- Frequent Inspection and Maintenance – Every 90 Days or 150 Hours
- Annual Maintenance – Every 500 Hours

The Daily Prestart Inspection must be performed by a trained operation. All other maintenance and inspection must be performed by a trained service technician only. Retain a copy of these forms for your records.

All placards and decals on the machine must be in place and legible. Use the Placards and Decals parts page in the Repair Parts section of this manual to check these placards and decals.

Snorkel recommends that you make additional copies of the preventative inspection and maintenance checklists for your use in performing these inspections.

### Warning

**The potential for accident increases when operating an aerial platform that is damaged or malfunctioning. Death or serious injury can result from such accidents. Do not operate the aerial platform if it is damaged or malfunctioning.**

Repair all defects before returning the machine to service.

### General Information

The parts drawings located in the Repair Parts section are designed for use as a guide for proper disassembly of the machine and components, as well as, for parts replacement.

### Danger

**Hydraulic fluid escaping under pressure can have enough force to inject fluid into the flesh. Serious infection or reaction will result if medical treatment is not given immediately. In case of injury by escaping hydraulic fluid, seek medical attention at once.**

Always refer to the hydraulic system installation drawings and the electrical wiring diagram before removing or disassembling associated parts.

When disassembling or reassembling components, complete the procedural step in sequence. Do not partially disassemble or assemble one part, then start on another. Always check your work to assure that nothing has been overlooked.

Keep the following in mind when disassembling or assembling the machine.

- Always be conscious of weight.
- Never attempt to lift heavy objects without the aid of a mechanical device.
- Do not allow heavy object to rest in an unstable condition.
- Always make sure the work platform is in the stowed position, blocked or the weight removed by a suitable lifting device before removing any components from the machine.
- When raising a portion of the machine, be sure that adequate blocking is properly positioned. Do not depend solely on the lifting device to hold and secure weight.
- If a part resists removal, check to see if all fasteners, electrical wiring, hydraulic lines, etc., have been removed or that other parts are not interfering.

---

Parts should be thoroughly inspected before restoring to service at the time of reassembly. Burrs, nicks or scratches may be removed from machines surfaces by honing or polishing with a #600 crocus cloth, followed by a thorough cleaning with an approved cleaning solvent, and blown dry with compressed air. Do not alter the contour of any part. If this operation does not restore the part to a serviceable condition, replace the part.

Replace all o-rings, seals and gaskets at reassembly. Use new roll pins or cotter pins. Dip all packing rings and seals in hydraulic oil before reassembling in cylinder and manifolds. Replace any part having imperfect threads. In general, machines that have been disassembled can be reassembled by reversing the order of disassembly.

The service life of a machine can be increased by keeping dirt and foreign materials out of the vital components. Shields, covers, seals and filters help to keep air and oil supplies clean. However, these items must be maintained on a scheduled basis in order to function properly.

Clean surrounding areas, as well as the opening and fittings before disconnecting air or oil lines. As soon as a line or component is disconnected, cap or cover all openings to prevent the entry of dirt or foreign materials.

New parts should remain in their container until they are ready to be used.

Clearly mark or tag hydraulic lines and electrical wiring connections when disconnecting or removing them from the machine. This will assure that they are correctly reinstalled.

Proper assembly is critical to the successful rebuilding of any machine. Carefully, inspect any parts which are to be reused. If in doubt, replace.

“Safety First” is a good slogan.

Replace any guards and protective devices that have been removed to carry out maintenance and repair work.

## Daily Prestart Inspection

Item	Inspect For	Ok
<b>Operator's Manual</b>	In manual holder	
<b>Engine</b>		
Oil level	Between full and add marks	
Coolant	Proper fluid level	
Radiator	Cap tight, good condition and clean	
Air cooled engines	Air intake and fan free of obstructions Belt in good condition	
Fuel tank and line	Tank full, cap in place and tight/no leaks	
Air filter	Green indicator	
Charging system	Proper operation	
Cold weather start kit	No damage or deformation	
<b>Electrical System</b>		
Emergency power battery	Condition and charged for proper operation	
Battery fluid level and terminals	Proper level/clean, connectors tight	
Cables and wiring harness	No wear or physical damage	
<b>Hydraulic System</b>		
Fluid level	Between full and add marks	
Fluid filter	Verify operation in the green zone	
Hoses, tubes and fittings	No leaks	
Cold weather warm-up kit	Proper operation	
<b>Tires and Wheels</b>	Good condition, all wheel lug nuts present and tight	
<b>Lower Control System</b>		
Operation controls	Proper operation	
Emergency stop and emergency power	Shuts off lower controls/proper operation	
<b>Emergency Lowering</b>	Proper operation	
<b>Level Sensor</b>	Sounds tilt alarm	
<b>Flashing Light</b>	Proper operation	
<b>Sandblast Protection Kit</b>	In place and proper operation	
<b>Structures</b>		
Weldments – Chassis, turntable, booms, platform, etc.	Welds intact, no damage or deformation	
Slide Pads	In place, no damage or deformation	
Fasteners	In place and tight	
<b>Upper Control System</b>		
Guardrail system and lanyard anchors	Welds intact, no damage or deformation All fasteners in place, no loose or missing parts	
Operating controls	Proper operation	
Emergency stop and emergency power	Shuts off upper controls/proper operation	
Horn	Sounds when activated	
Electrical power outlet	Proper operation	
Drive motion alarm	Sounds when aerial platform moves	
Driving and work lights	Proper operation	
Platform control cover	In place and proper operation	
<b>Air Line</b>	Good condition, proper operation	
<b>Placards and Decals</b>	In place and readable	

Performed by: \_\_\_\_\_ Date: \_\_\_\_\_





## Frequent Inspection and Maintenance – Every 90 Days or 150 Hours

Item	Procedure	Information	OK
<b>Chassis</b>			
Structural	Check for damage and cracked welds		
Steering cylinder snap rings	Verify that all fasteners are in place and are tight		
Steering linkage	Check for proper operation		
Tires	Check for wear and damage		
Hydraulic tubes and hoses	Check for leaks, wear, and damage		
Drive motor brake	Check for proper operation		
Torque drive and steer wheel lug nuts per placard on wheel	Torque lug bolts/nuts to proper value on machine placard	Front: 450 to 500 ft lb Rear: 450 to 500 ft lb	
Right drive motors	Check for leaks		
Left drive motors	Check for leaks		
Tie-down and lifting lugs	Check for damage and cracked welds		
Decals and placards	Check for damage and readability Order replacements as necessary		
<b>Turntable</b>			
Structural	Check for damage and cracked welds		
Torque turntable top bolts	Torque to proper value	475 to 525 ft lbs	
Torque turntable bottom bolts	Torque to proper value	350 to 400 ft lbs	
Hydraulic tubes and hoses	Check for leaks, wear, and damage		
Centerpost	Check for leaks, wear, and damage		
Centerpost mounting bolts	Verify that all fasteners are in place and are tight		
Lift cylinder pin caps and tie wire	Verify that all fasteners are in place and are tight		
Lift cylinder and holding valve	Check for leaks, wear, damage, and for proper operation		
Master level cylinder pin caps and tie wire	Verify that all fasteners are in place and are tight		
Master level cylinder and holding valves	Check for leaks, wear, damage, and for proper operation		
Emergency bleed down valve	Check for proper operation		
Cowling	Check for wear/damage and that fasteners are in place and are tight		
Wire harness	Check for wear/damage and that fasteners are in place and are tight		
Rotation brake	Check for proper operation		
Rotation backlash	Check for wear and damage		
Operator's Manual	Proper manual in document holder		
System pressure	Check maximum system pressure	2,750 – 2,850 psi	
Decals and placards	Check for damage and readability Order replacements as necessary		

## Frequent Inspection and Maintenance – Every 90 Days or 150 Hours

Item	Procedure	Information	OK
<b>Lower Controls</b>			
Control switch in the lower controls position	Check for proper operation	With selector in the lower controls position, upper controls do not work	
Station selector switch in the upper controls position	Check for proper operation	With selector in the upper controls position, lower controls do not work	
Engine Start – Stop	Check for proper operation		
Throttle High – Low	Check for proper operation		
Turntable CW – CCW	Check for proper operation		
Boom elevation Up – Down	Check for proper operation		
Boom Extend – Retract	Check for proper operation		
Jib Up – Down	Check for proper operation		
Jib rotation CW – CCW	Check for proper operation		
Platform level Up – Down	Check for proper operation		
Platform rotation CW – CCW	Check for proper operation		
Emergency power, all functions	Check for proper operation		
Emergency stop	Check for proper operation		
<b>Booms</b>			
Structural	Check for damage and cracked welds		
Lift cylinder pin caps and tie wire	Verify that all fasteners are in place and are tight		
Hydraulic tubes and hoses	Check for leaks, wear, and damage		
Extension cylinder pin caps and tie wire	Verify that all fasteners are in place and are tight		
Extension cylinder and holding valve	Check for leaks, wear, damage, and for proper operation		
Jib boom pin caps and snap rings	Verify that all fasteners are in place and properly installed		
Jib cylinder pin caps and snap rings	Verify that all fasteners are in place and properly installed		
Jib cylinder and holding valve	Check for leaks, wear, damage, and for proper operation		
Slave level cylinder pin caps and tie wire	Verify that all fasteners are in place and are tight		
Slave level cylinder and holding valves	Check for leaks, wear, damage, and for proper operation		
Hose carrier tube and support	Check for residue buildup/proper operation		
Plastic hose track	Check for wear and damage		
Electrical wires	Check for wear and damage		
Decals and placards	Check for damage and readability Order replacements as necessary		

## Frequent Inspection and Maintenance – Every 90 Days or 150 Hours

Item	Procedure	Information	OK
<b>Platform</b>			
Structural	Check for damage and cracked welds		
Entry Gate	Check for proper operation		
Hydraulic tubes and hoses	Check for leaks, wear, and damage		
Slave level cylinder pin caps and tie wire	Verify that all fasteners are in place and are tight		
Slave level cylinder holding valves	Check for leaks, wear, damage, and for proper operation		
Decals and placards	Check for damage and readability Order replacements as necessary		
<b>Upper Control Station</b>			
Foot switch	Check for proper operation	With the foot switch engaged the engine should not start. Functions should be operational when foot switch is engaged	
Engine Start – Stop	Check for proper operation		
Throttle High – Low	Check for proper operation		
Turntable CW – CCW	Check for proper operation		
Boom elevation Up – Down	Check for proper operation		
Boom Extend – Retract	Check for proper operation		
Jib Up – Down	Check for proper operation		
Platform level Up – Down	Check for proper operation		
Platform rotation CW – CCW	Check for proper operation		
Drive speed	Boom up and/or extended Low – 1.0 mph	1 mph = 100 ft in 65 to 75 sec	
	Boom down and retracted High – 3.0 mph	3 mph = 100 ft in 22 to 28 sec	
Drive range – boom stowed	Check for proper operation	Slow speed only with boom raised	
Engine choke – gas engine only	Check for proper operation		
Emergency power, all functions	Check for proper operation		
Emergency stop	Check for proper operation		
Horn	Check for proper operation		
Gradual start to stop lift/swing/ drive controls	Check for proper operation		
Speed limit switch	Check for proper operation		
Tilt alarm	Check for proper operation	5° NonCE/3.5° CE	
110 volt AC power to platform	Check for proper operation		
<b>Hydraulic Oil Reservoir</b>			
Filler/breather cap and tank	Check for wear/securely fasten		
Hydraulic fluid level	Check for proper level	Above 10°F (-13°C) Mobil DTE-13M, ISO VG32 Below 10°F (-13°C) Mobil DTE-11M, ISO VG15	
Hydraulic filter	Replace after the first 50 hours, every 90 days or 150 hours thereafter Inspect filter for foreign matter that could indicate component wear		

## Frequent Inspection and Maintenance – Every 90 Days or 150 Hours

Item	Procedure	Information	OK
<b>Engine</b>			
Charging system	Check for proper operation		
Air filter	Check for wear and damage		
Hour meter	Check for proper operation		
Belts and hoses	Check for wear and damage		
Hydraulic pump	Check for proper operation		
Battery terminals	Clean terminals and check cable condition		
Battery electrolyte	Check electrolyte levels	Add distilled water if necessary	
Indicator gauges	Check for wear/damage and proper operation		
Engine oil	Check for wear and damage/level	Between add and full	
Engine coolant	Check level	Between add and full	
Engine Start – Stop	Check for proper operation		
Electric throttle	Check for proper operation		
Electric choke, if equipped	Check for proper operation		
Engine governor setting	Check for proper operation		
<b>Platform Rotator</b>			
Structural	Check for damage and cracked welds		
Hydraulic rotator actuator	Check for leaks, wear, and damage		
Platform rotation holding valve	Check for proper operation		
Mounting bolts and pin caps	Verify that all fasteners are in place and are tight		
<b>Options</b>			
110 volt AC generator	Check for proper operation		
220 volt AC generator	Check for proper operation		
Dual fuel system	Check condition and for proper operation		
LP gas system and control	Check condition and for proper operation		
Drive motion alarm	Check for proper operation		
Flashing light	Check for proper operation		
Cold weather start kit – diesel only	Check for proper operation		
Hydraulic system cold weather warm up kit	Check for proper operation		
Driving lights	Check for proper operation		
Platform work lights	Check for proper operation		
Platform control cover	Check condition and for proper operation		
Sandblast protection kit	Check for proper operation		
Airline to platform	Check for proper operation		
Spark arrestor muffler – Deutz only	Check for wear and damage		
Platform welder	Check condition and for proper operation		
Platform glazier package	Check condition and for proper operation		
Optional platform	Verify that all fasteners are in place and are tight		

## Frequent Maintenance – Every 90 Days or 150 Hours

Item	Procedure	Information	OK
Daily maintenance	Perform maintenance as per schedule	Retain copy of checklist	
Preventive inspection maintenance checklist	Perform inspection, complete form	Retain copy of checklist	
Placards and decals inspection	Inspect using drawing and parts listing in Section 1 – Repair Parts Manual	Replace any missing or unreadable decals/placards	
Door hinges and latches	Lubricate	SAE 10W oil or spray lubricant	
Rotation bearing	Lubricate	Conoco Super Sta #2 Above 32° F Mobilgrease CM-P Below 32° F Mobilgrease CM-L	
Rotation bearing teeth and pinion	Lubricate	Mobil Mobiltac 375NC	
Tie rods	Lubricate	Conoco Super Sta #2 Above 32° F Mobilgrease CM-P Below 32° F Mobilgrease CM-L	
Gear hubs	Check fluid level, fill if low	Mobil Mobilube HD 80W-90	
Swing drive	Check fluid level, fill if low	Mobil Mobilube HD 80W-90	
Platform rotator	Refill if disassembled for repairs	Consult factory	
Platform controller	Check smooth operation/speeds		
Batteries	Check specific gravity	1.260/1.275 at 80° F (26° C)	
Hydraulic return filter	Check condition	Replace if dirty	
Engine rpm	Check for proper engine rpm	See engine owner's manual	
Engine oil and filter	Replace per engine owner's manual	See engine owner's manual	
Engine fuel filter	Check condition	Replace every 6 months or if dirty	

Performed by: \_\_\_\_\_ Date: \_\_\_\_\_



## Annual Maintenance – Every 500 Hours

Item	Procedure	Information	OK
90 day or 150 hour maintenance	Perform maintenance per schedule	Retain copy of checklist	
Hydraulic oil reservoir	Clean and replace fluid	Above 10° F (-13° C) Mobil DTE-13M, ISO VG32 Below 10° F (-13° C) Mobil DTE-11M, ISO VG15	
Hydraulic return filter	Replace	After first 50 hours, then at recommended interval	
Hydraulic reservoir suction filter	Clean and reinstall		
Hydraulic pressures	Pump setting	Standby pressure: 350-375 psi	
	Function pressures	Boom up: 2,450-2,550 psi	
		Boom down: 800-900 psi	
		Steer: 2,800-3,000 psi	
		Level: 3,000 psi	
		Extend: 1,450-1,550 psi	
		Retract: 2,450-2,550 psi	
Swing: 1,250-1,350 psi			
Gear hubs	Replace fluid	Mobil Mobilube HD 80W-90	
Swing drive	Replace fluid	Mobil Mobilube HD 80W-90	
Engine coolant	Check condition	See engine owner's manual	

Performed by: \_\_\_\_\_ Date: \_\_\_\_\_





## Major Repairs

Date	Part Number	Part Description	Repair Performed



# Lubrication Points

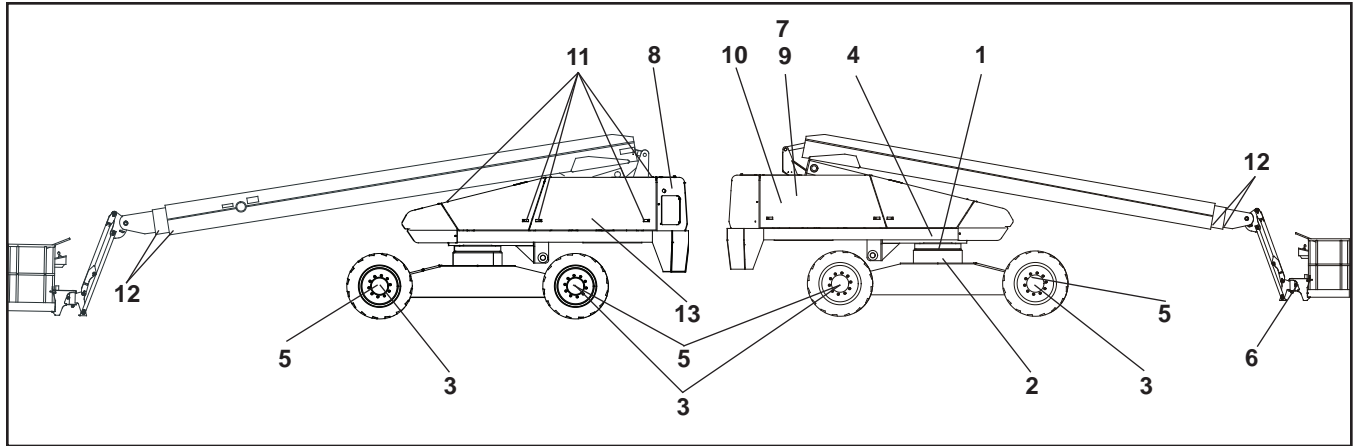

## Lubrication

Specific lubricants as recommended by Snorkel, should be used in maintaining the unit. If in doubt regarding the use of lubricants other than those listed, contact Snorkel Customer Service Department for evaluation and recommendation.

Refer to the above lubrication illustration to locate component item numbers.

Service all fittings as indicated on the Frequent Maintenance schedule and lubrication illustration. Wipe away all excess lubricant from exposed surfaces. Over lubrication can collect dirt and foreign matter which acts as an abrasive. Lubrication of accessory equipment should be in accordance with the manufacturer's recommendations.

## Rotation Bearing

Rotation bearing – Item 1. Pressure gun lubricate bearing at recommended interval using lubricant as outlined in the maintenance schedule. Rotate while lubricating. The lubrication fitting is located on the turntable below the lower controls.

## Rotation Gear Teeth and Pinion

Rotation gear teeth and pinion – Item 2. Gear teeth and gear box pinion should be lubricated with a spray-on type open gear lubricant.

## Tie Rods

Tie rods – Item 3. Lubricate at recommended interval using lubricant as outlined in the maintenance schedule.

## Swing Drive

Swing drive – Item 4. To check oil level, remove check plug located on the side of the gear box. Unit is full if oil is level with bottom of fill hole or just starts to run out.

## Gear Hubs

Gear hubs – Item 5. To check and fill Gear hubs:

1. Rotate wheel until bottom of filler/drain plug is about 1 inch above horizontal centerline.
2. Remove plug with drive ratchet and extension.
3. Fill until lubricant is level with bottom of fill hole.



## Note

*Do not overfill gear hubs as they are not vented and need air space for expansion of oil to prevent damage to hubs.*

## Platform Rotator

Platform Rotator – Item 6. Platform rotators will require lubrication only if disassembled for repairs. Consult factory for proper lubricant if replacement of platform rotator is required.

## Hydraulic Oil Reservoir

Hydraulic oil reservoir – Item 7. The fluid level should be kept between the full and add marks on the sight gauge and should be checked with the machine in the stowed position.

The interior of the reservoir should be wiped out and cleaned each time the hydraulic oil is changed. The reservoir filler/breather cap should be removed and the cap strainer cleaned with Kerosene, fuel oil, or other solvent at this time.

It is absolutely necessary that only new, clean hydraulic oil is added.

## Note

*If it becomes necessary to add or use an oil other than the recommended fluid, it is important that it be compatible and equivalent to the factory fill. Local oil suppliers can generally furnish this information.*

If questions still remain, contact Snorkel Customer Service Department for further information.

## Engine

Engine – Item 8. Refer to the engine manufacturer's instruction manual or consult your local engine service representative if engine adjustments or repairs are needed. The engine must be operated in accordance with manufacturer's instructions and serviced at recommended intervals.

---

### Hydraulic Oil Return Filter

Return filter – Item 9. The hydraulic oil return filter is mounted outside of the hydraulic oil reservoir.

The filter element is a throw-away type filter and should be changed after the initial break-in period (approximately 50 hours operation time).

The filter is equipped with a hydraulic pressure gauge to indicate the filter element condition. A by-pass relief within the filter base is provided and is set to by-pass at 25 psi. If pressure readings are above 25 psi, the filter should be changed.

The filter condition should be checked at the 90 day or 150 hour Preventive Inspection Maintenance interval or more frequently under extreme working conditions.

The filter condition indicator is accurate only when the engine is running at maximum rpm and pump is discharging maximum flow, which occurs only during full speed driving. This requires that the indicator be observed while the unit is in motion, booms fully retracted and in stowed position, drive range switch in "LO" position, and drive controller fully forward. Oil temperature should be at least 90° F (32° C).

### Warning

**Use extreme caution while observing the condition indicator because of the motion of the drive wheels. The condition indicator is best observed from outside of the tract of the vehicle wheels to avoid possible personal injury or machine damage.**

When changing the filter element, the oil inside of the filter element, should be examined for deposits of metal cuttings, which is present, could indicate excessive wear in some of the system components.

### Suction Strainer

Suction strainer – Item 10. A 100 mesh strainer is located within the hydraulic oil reservoir and filters the pump suction flow.

The strainer should be cleaned at the time interval shown in the maintenance schedule chart, using Kerosene, fuel oil or other solvent and a soft bristled brush.

Inspect the filter wire cloth for damage. Holes in the filter cloth leak dirt into the pump and other vital hydraulic components. If element is damaged, replace.

When the filter has been thoroughly cleaned, reinstall in suction line and tighten securely.

### Door Hinges and Latches

Door hinges and latches – Item 11. After lubricating, remove any excess lubricant or over spray so it will not collect dirt or debris.

### Slide Pads

Slide pads – Item 12. Check slide pads for excessive wear and replace as required. Slide pads do not require lubrication.

### Batteries

Batteries – Item 13. Batteries will have longer life if the water level is maintained and they are kept charged. The engine will have better starting characteristics with a fully charged battery. In cold weather the battery should be maintained at full charge to keep from freezing. An extremely low or dead battery can freeze in cold weather. Make sure connections are clean and tight.

Make sure charging equipment is operating properly.

### Danger

**Lead-acid batteries produce flammable and explosive gases. Never allow smoking, flames or sparks around batteries. Lead-acid batteries contain sulfuric acid which will damage eyes or skin on contact. When working around batteries, always wear a face shield to avoid acid in eyes.**

If acid contacts eyes, flush immediately with clear water and get medical attention. Wear rubber gloves and protective clothing to keep acid off skin, if acid contacts skin, wash off immediately with clear water.

### Battery Care and Maintenance

The following information about battery care and maintenance was supplied by Interstate Batteries and is reprinted here with their permission.

1. New batteries need to be cycled several times before reaching full capacity (20-50 cycles, depending on type). Usage should be limited during this period.
2. Always recharge batteries fully, immediately after use. Batteries perform best when they are fully charged. More capacity and longer life will result from this practice.
3. The deeper the discharge, the fewer number of cycles a lead-acid battery will deliver. Deep discharges deteriorate the battery quicker than lighter shallow cycles.
4. Battery cables should be intact and connectors kept tight at all times. Systematic inspection is recommended.
5. Vent caps should be kept in place and tight during vehicle operation and battery charging.
6. Batteries should be kept clean – free of dirt and corrosion – at all times. Always keep the top of batteries clean. A film on top of the battery can cause the current to migrate between the posts, accelerating self discharge.

- 
7. Never let the electrolyte level of a lead-acid battery fall below the plates. Lack of maintaining the electrolyte in a lead-acid battery causes damage to the exposed portion of the plate which reduces capacity.
  8. Always check electrolyte level before charging. Do not add water to individual cells unless plates are exposed. Batteries should be watered after charging unless the plates are exposed before charging. If exposed before charging, the plates should be covered by approximately 1/8" of water. Check water level after charging. Water should be kept 1/4" below the bottom of the fill tube in the cell cover.
  9. Water used to replenish batteries should be distilled or treated to not exceed 200 T.D.S. (total dissolved solids... parts per million). Particular care should be taken to avoid metallic solids (iron).
  10. A fully charged battery will give you the best and longest service. Be sure the batteries are fully charged before testing or using. A fully charged battery, without a drain or load, after the surface charge has dissipated, is 6.35 volts for a 6 volt battery.
  11. Batteries should not be discharged below 20% of capacity (approximately 1.8 volts per cell under normal operating load; 1.98 volts open circuit; 1.145 specific gravity). Proper battery sizing will help avoid excessive discharge.
  12. Battery chargers should be sized to fully charge batteries in an eight hour period. Chargers should be kept in proper operating condition.
  13. Do not use a mismatched charger of any type; i.e., a 12 volt charger on a 24 volt pack or a 24 volt charger on a 12 volt pack. An undersized charger will never get the job done, no matter how long it tries. An oversized charger will cause excess gassing and heat that could possibly result in a battery meltdown and/or explosion.
  14. Never charge a lead-acid battery with a sealed (gel cell) battery charger. The lead-acid battery needs higher voltage to finish its charge. Without it the battery will never come back to 100% and sulfation can occur.
  15. Always allow batteries to cool off after charging. The cooling time is very important because heat is generated during the recharge and discharge cycles. Without the cooling time the heat grows, accelerating grid corrosion which is one of the major causes of battery failure. Charging practice should enable batteries to cool before use.
  16. Deep cycle batteries need to be equalized periodically. Equalizing is an extended, low current charge performed after the normal charge cycle. It helps keep cells in balance. Actively used batteries should be equalized once per week. Manually timed chargers should have the charge time extended approximately 3 hours. Automatically controlled chargers should be unplugged and reconnected after completing a charge cycle.
  17. In situations where multiple batteries are connected in series, parallel or series-parallel, a replacement battery's should be of the same size, age and usage level as the companion batteries. Do not put a new battery in a pack that has 50 or more cycles. Either replace all the batteries with new batteries or install a good used battery's in place of the bad. New batteries should be given a full charge before use.
  18. Periodic battery testing is an important preventative maintenance procedure. Hydrometer readings of each cell (fully charged) give an indication of balance and true charge level. Imbalance could mean the need for equalizing and is often a sign of improper charging or a bad cell. Voltage checks (open circuit, charged and discharged) can locate a bad cell or weak battery. Load testing will pick out a bad cell when other methods fail. The point is to look for the abnormal. A weak cell or battery will cause premature failure of companion cells or batteries respectively.
  19. As batteries age, their maintenance requirements change. Generally their specific gravity is higher and gassing voltage goes up. This means longer charging time and/or higher finish rate (higher amperage at the end of charge). Usually, older batteries need to be watered more often and their capacity decreases.
  20. "Opportunity charging", a short partial charge during an extended duty cycle, is a controversial subject. Generally, the practice is a "crutch" to make up for undersized batteries. The correct approach is to install adequate battery capacity. If this is impossible because of lack of space in the battery compartment or extreme operating conditions (24 hour intermittent use, as an example), "opportunity charging" is better than excessive battery discharging. However, the practice can cause batteries to overheat, require more watering and usually will shorten battery life. "Opportunity charging" is a trade off; something to avoid if possible. One charging cycle per day is preferable.
  21. Extreme temperatures can substantially affect battery performance and charging. Cold reduces battery capacity and retards charging. Heat increases water usage and can result in overcharging. Very high temperature can cause "thermal run away" which may lead to an explosion or fire. If extreme temperature is an unavoidable part of an application, consult a battery/charger specialist about ways to deal with the problem.





---

22. An overly discharged battery might need to be cycled a few times before it can recover fully. If a battery begins to heat before coming up to a full charge, it might be necessary to discharge the battery and recharge it a few times. The charge and discharge cycle might help the current acceptance of the battery and facilitate its recovery to a usable condition.

23. Inactivity can be harmful to deep cycle batteries. If they sit for several months, a “boost” charge should be given – more frequently in warm climate (about once a month) than in cold (every 2-3 months).

24. Never store a battery in a discharged state. The sulfate that forms during discharge can make the battery impossible to recharge fully.

## Fastener Torque Chart

Bolt Grade	SAE Grade 1 or 2	SAE Grade 5	SAE Grade 6	SAE Grade 8
Marking				
Definition	Indeterminate Quality	Minimum Commercial Quality	Medium Commercial Quality	Best Commercial Quality
Material	Low Carbon Steel	Medium Carbon Steel Tempered	Medium Carbon Steel Quenched and Tempered	Medium Carbon Alloy Steel Quenched and Tempered
Minimum Tensile Strength	64,000 psi.	105,000 psi	133,000 psi.	150,000 psi
Bolt Size	Recommended Torque Value (ft lbs)			
1/4	5	7	10	10.5
5/16	9	14	19	22
3/8	15	25	34	37
7/16	24	40	55	60
1/2	37	60	85	92
9/16	53	88	120	132
5/8	74	120	167	180
3/4	120	200	280	296
7/8	190	302	440	473
1	282	466	660	714

Torque chart information:

- Consult manufacturers' specific recommendations, when available.
- The chart may be used with both coarse and fine thread fasteners lightly lubricated.
- Increase torque by 20% when multiple tapered tooth (shake proof) lock washers are used.
- The torque values are given in foot-pounds.
- Inch/pound equivalent may be obtained by multiplying by 12.





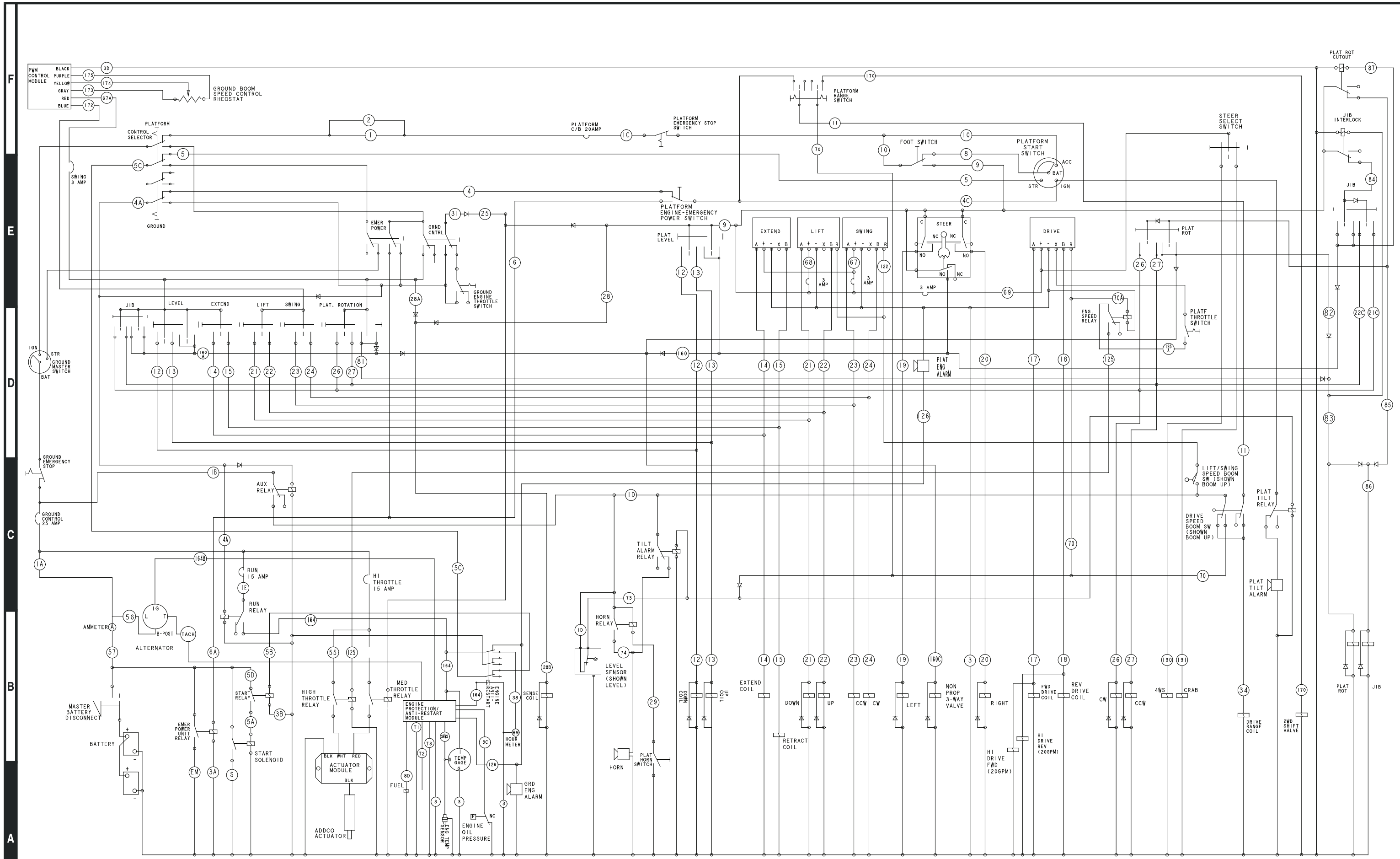

A

B

C

D

E

F

1

2

3

4

5

6

7

8

9

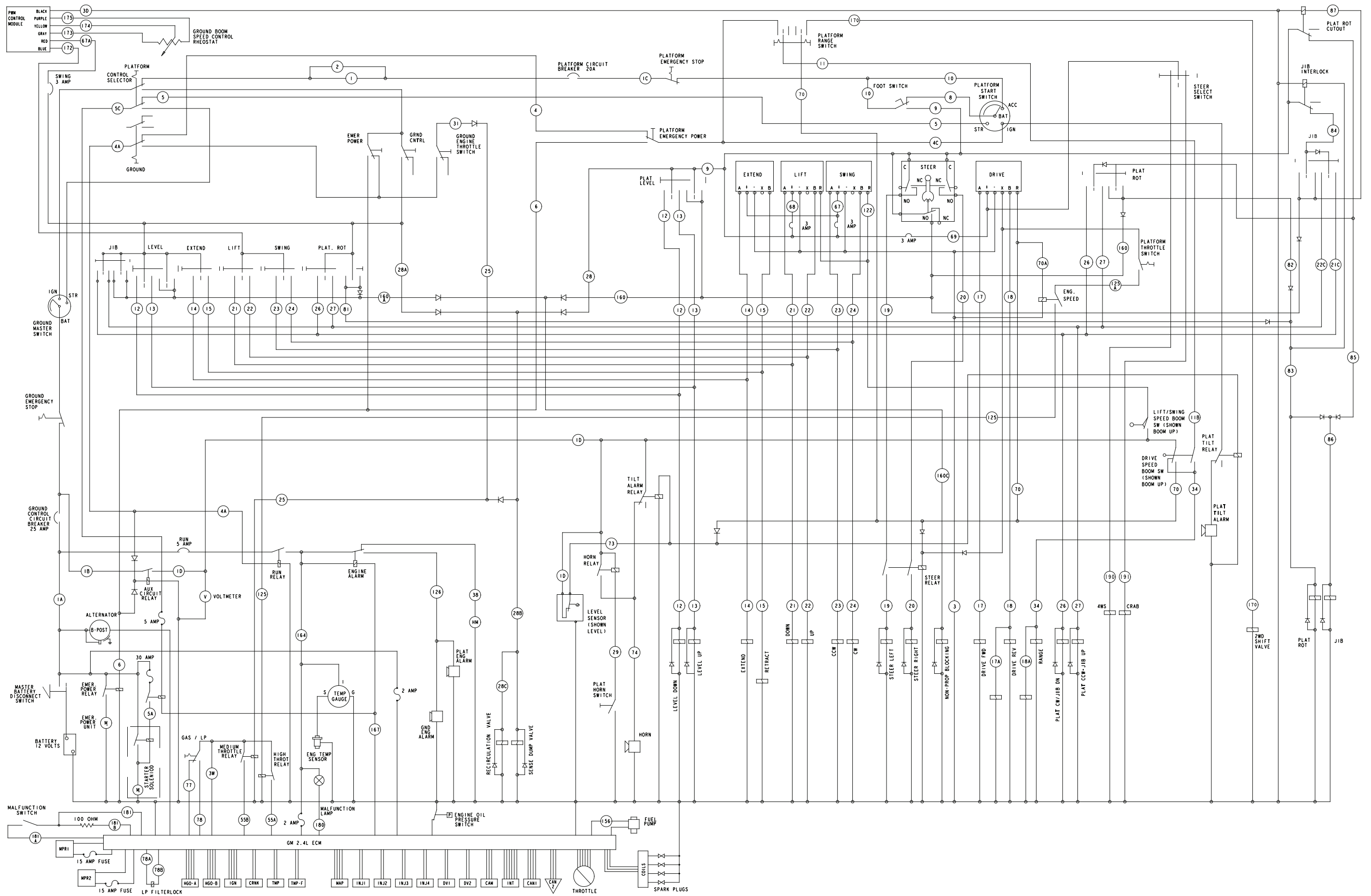

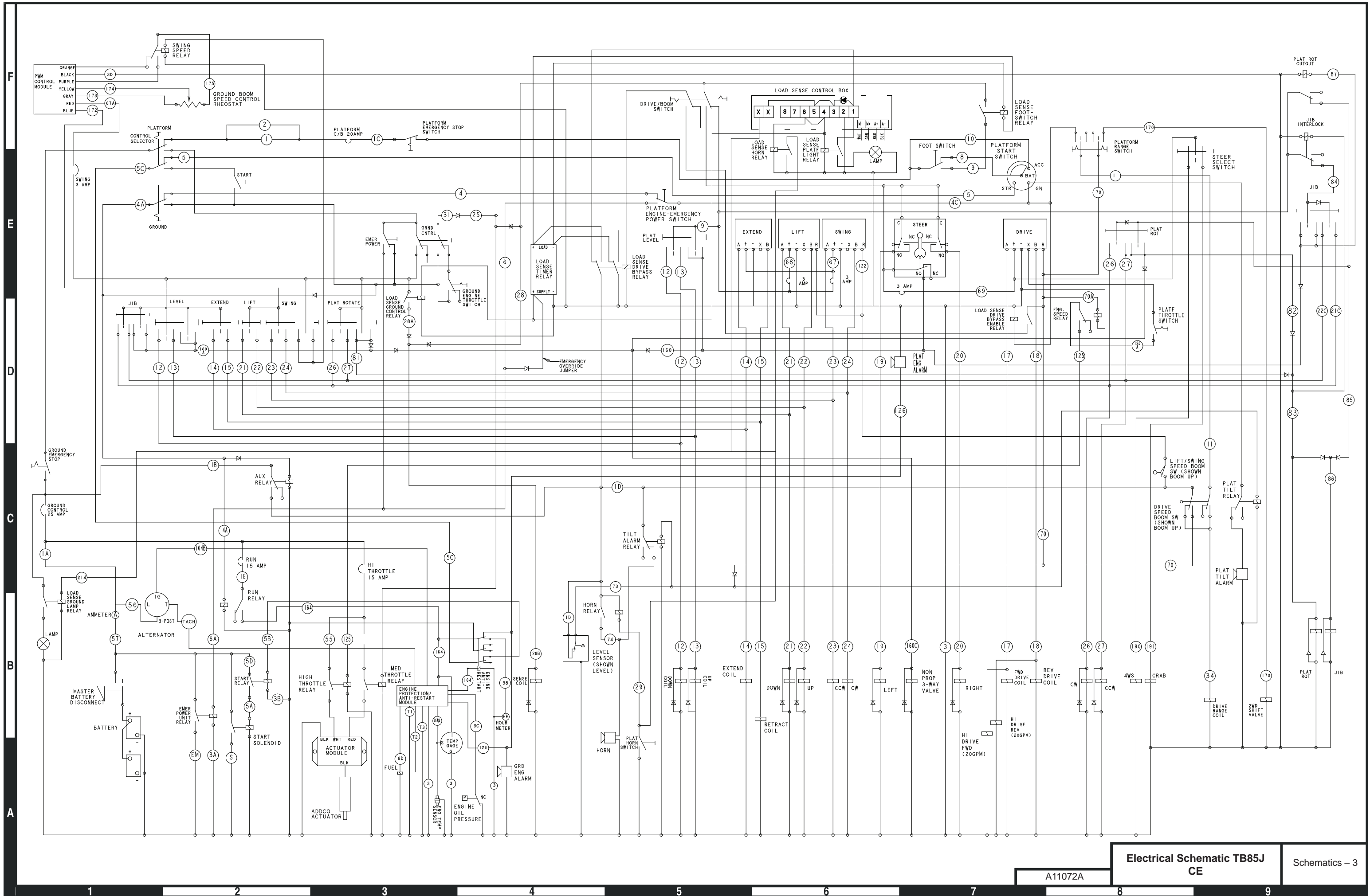

Electrical Schematic TB85J  
CE

A11072A

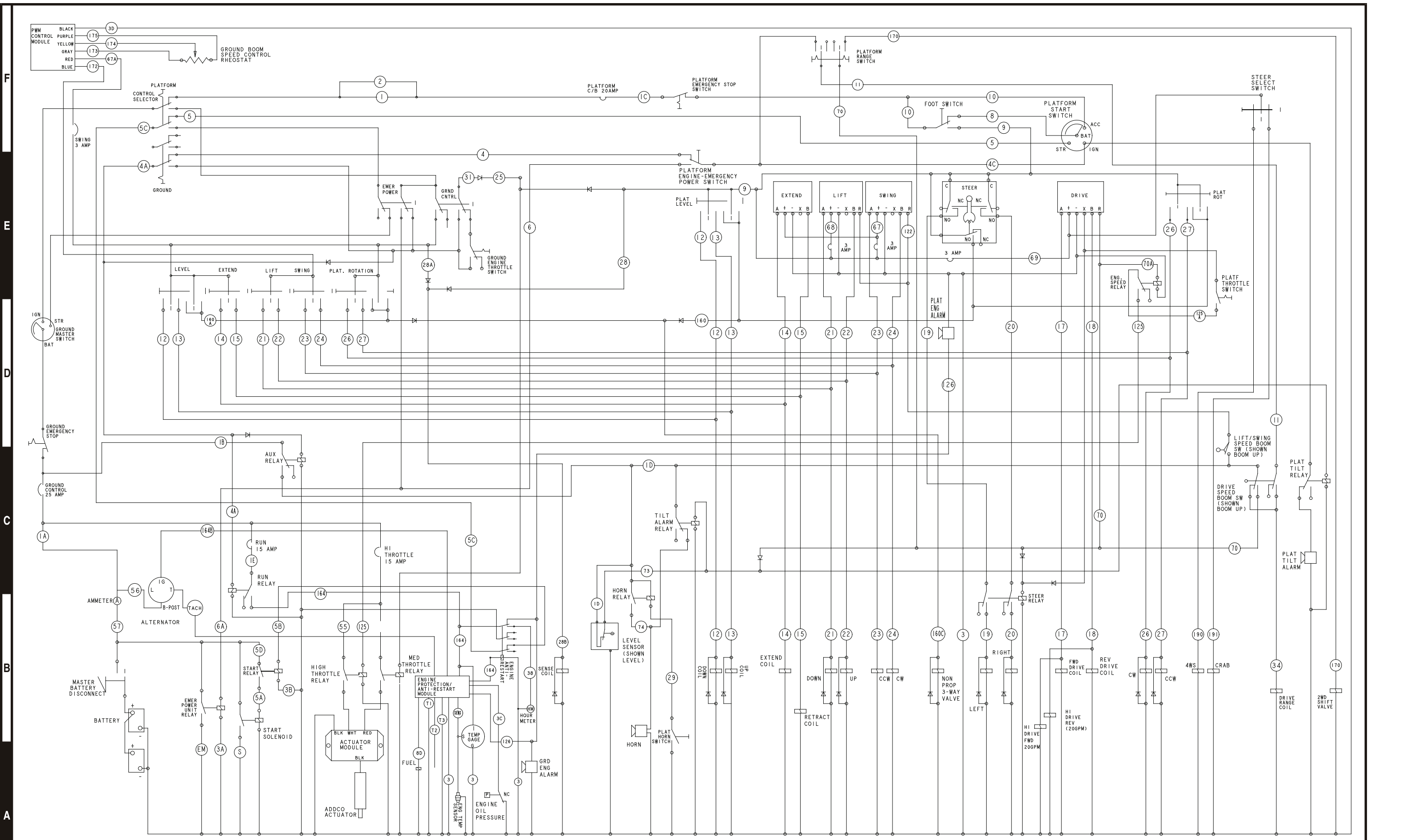

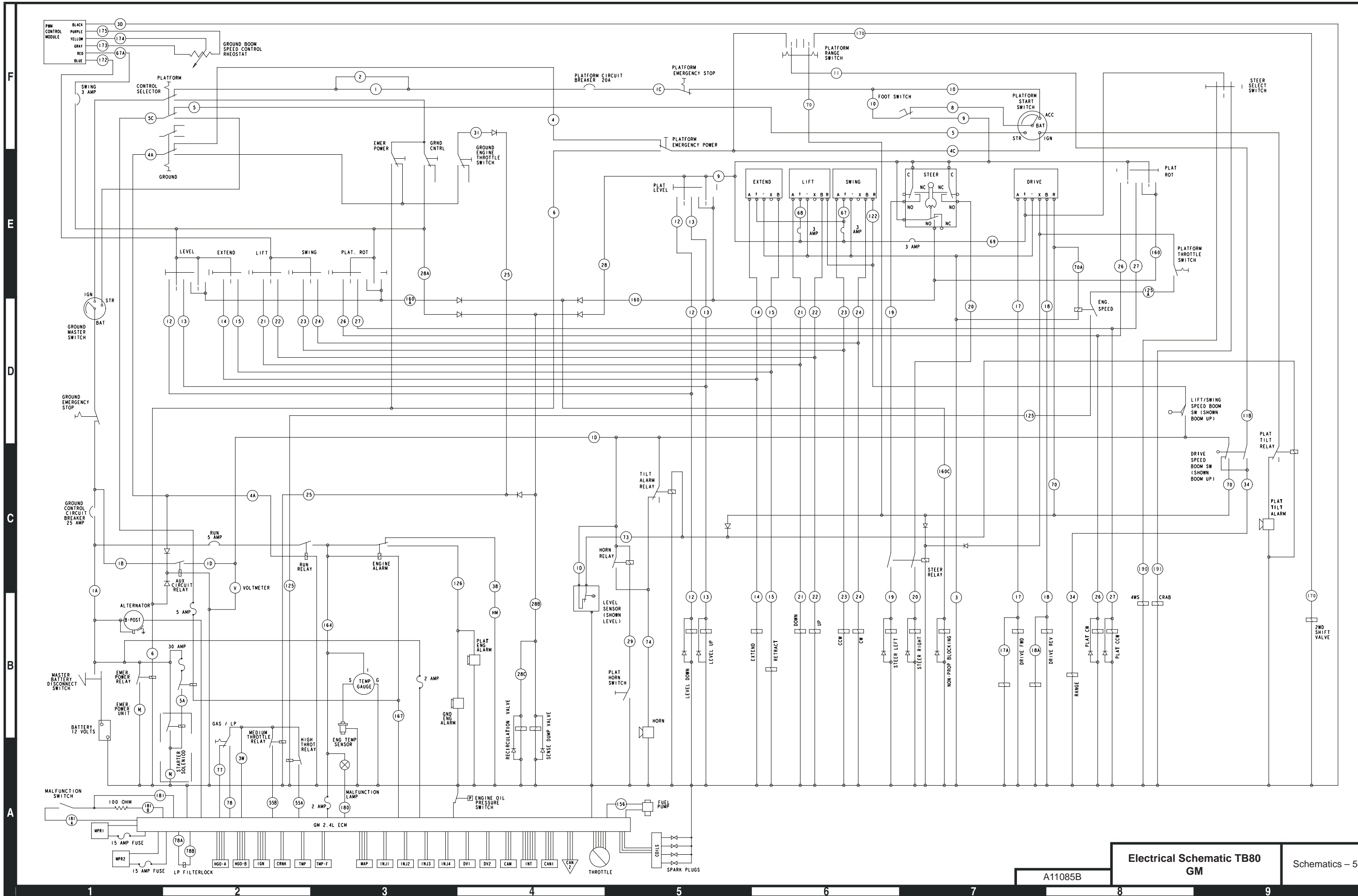

Electrical Schematic TB80  
GM

A11085B

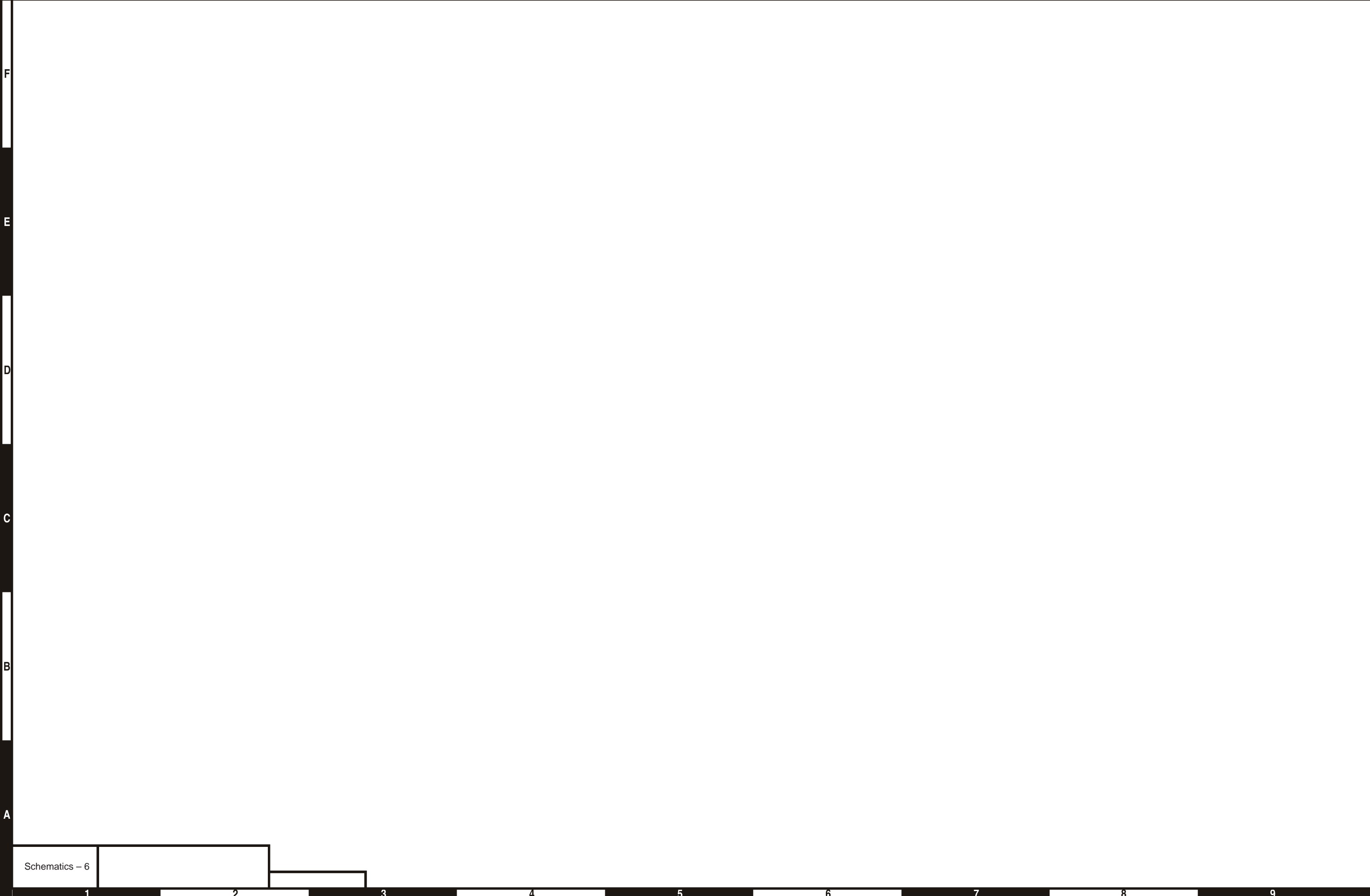

F

E

D

C

B

A

Schematics - 6

1

2

3

4

5

6

7

8

9

F

E

D

C

B

A

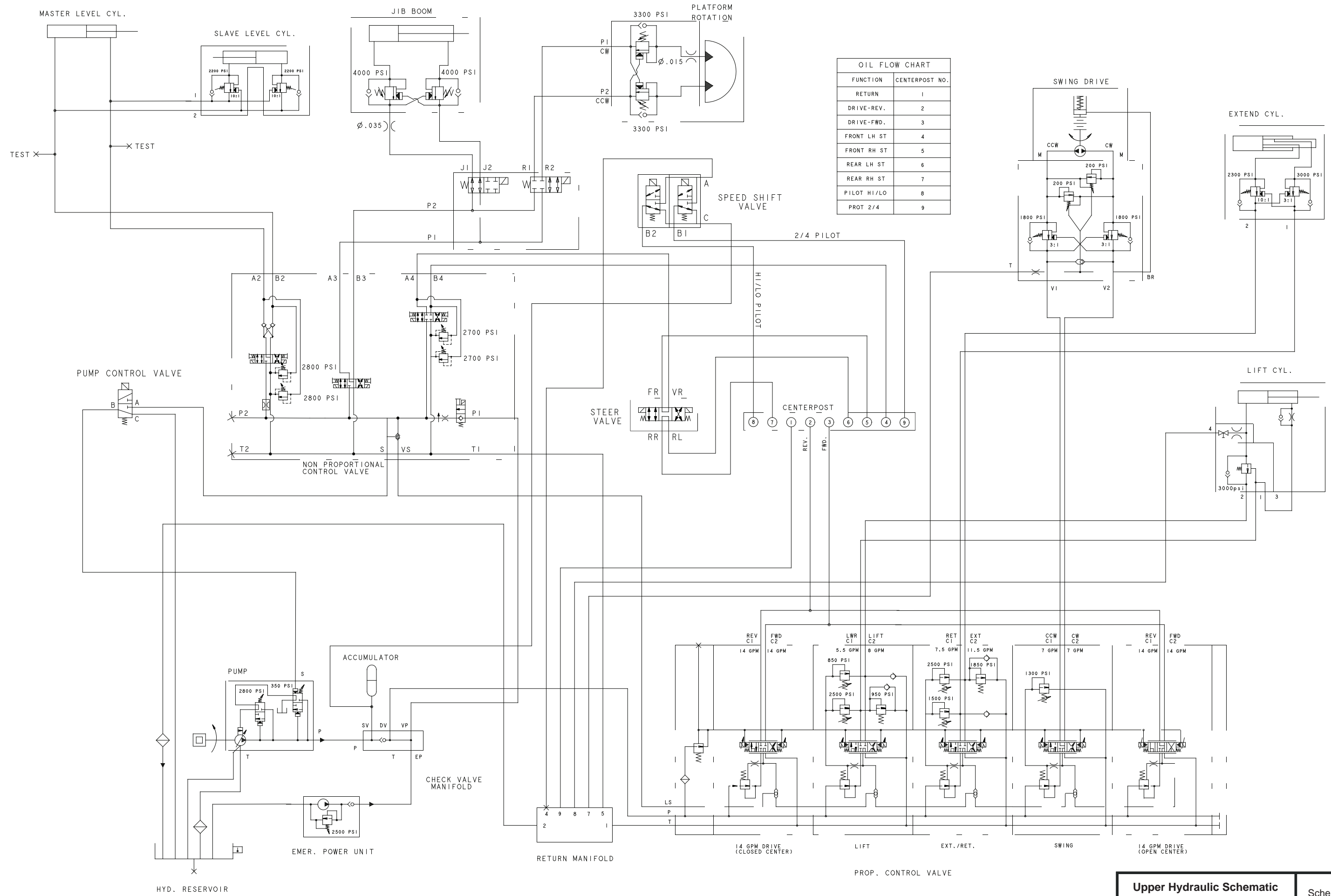

FUNCTION	CENTERPOST NO.
RETURN	1
DRIVE-REV.	2
DRIVE-FWD.	3
FRONT LH ST	4
FRONT RH ST	5
REAR LH ST	6
REAR RH ST	7
PILOT HI/LO	8
PROT 2/4	9

Upper Hydraulic Schematic  
TB80/TB85J

A11077A

1 2 3 4 5 6 7 8 9

OIL FLOW CHART	
FUNCTION	CENTERPOST NO.
RETURN	1
DRIVE-REV	2
DRIVE-FWD	3
FRONT LH STEER	4
FRONT RH STEER	5
REAR LH STEER	6
REAR RH STEER	7
PILOT-HI/LO	8
PILOT-2/4	9

NOTES:  
 1. STEERING CONFIGURATION APPLIES TO 2WD AND COORDINATED STEER ONLY.

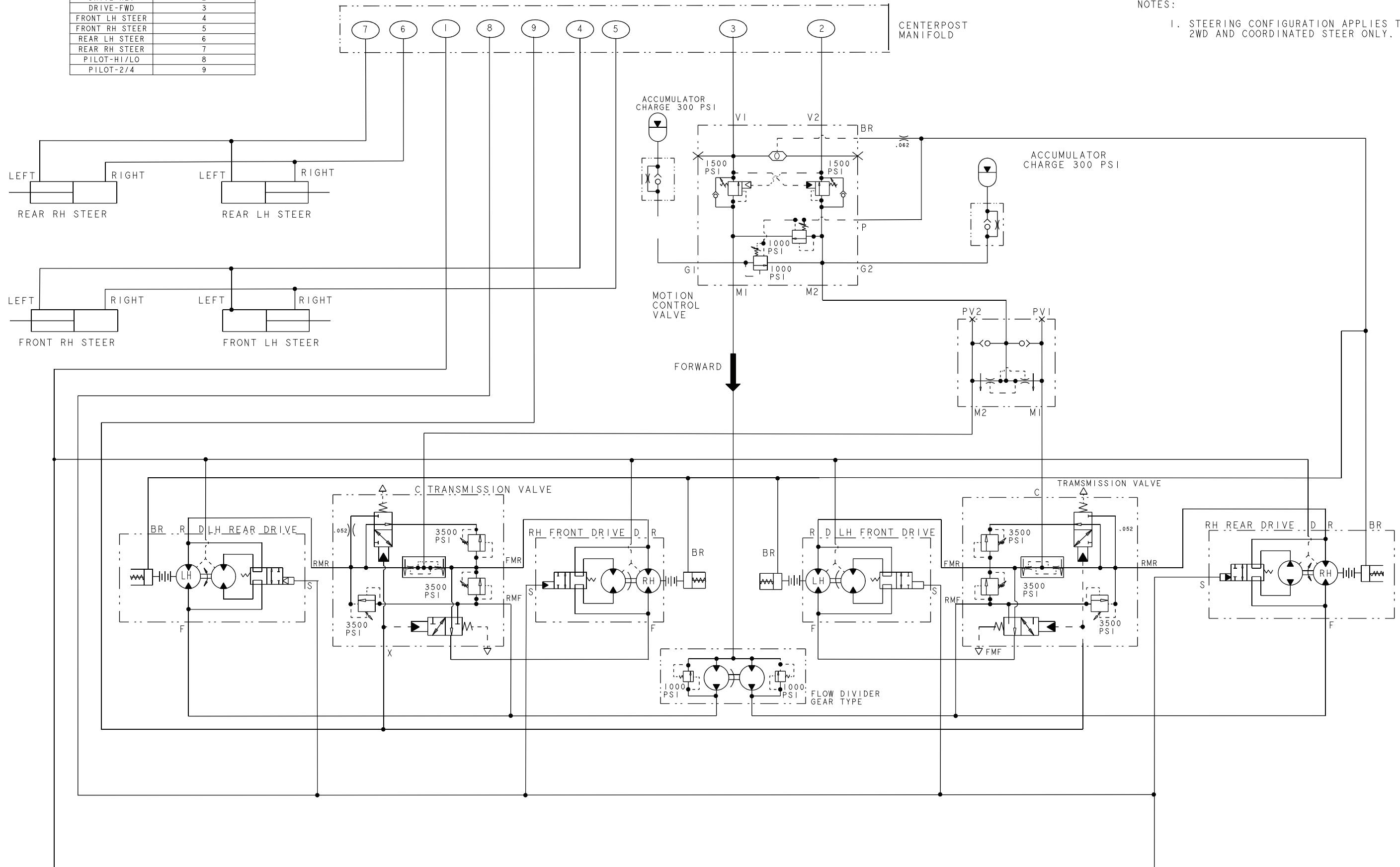





## Product Warranty

1. Snorkel warrants each new machine manufactured and sold by it to be free from defects in material and workmanship for a period of one (1) year from date of delivery to a Customer. The warranty will apply subject to the machine being operated in accordance with the rules, precautions, instructions and maintenance requirements outlined in the Snorkel Operator's and Repair Parts Manuals.
2. Snorkel further warrants the structural components, specifically the mainframe chassis, turntable, booms and/or scissor arms of each new machine manufactured by it to be free from defects in material and workmanship for an additional period of four (4) years. Any such part or parts which, upon examination by the Snorkel Warranty Department, are found to be defective will be replaced or repaired by Snorkel through its local Authorised Dealer. The structural warranty specifically excludes adverse affects on the machine structure arising from damage, abuse or misuse of the equipment.
3. Machines may be held in an authorised Distributor stock for a maximum of six (6) months from the date of shipment from Snorkel, before the warranty period is automatically initiated.
4. It is the responsibility of the Distributor to complete and return a Predelivery/Warranty registration, before the act of rental/loan/demonstration of the machine or delivery to an end user.
5. The Customer and Dealer shall not be entitled to the benefits of this warranty and Snorkel shall have no obligations here under unless the "Predelivery and Inspection Record" has been properly completed and returned to the Snorkel Warranty department within fifteen (15) days after delivery of the Snorkel product to the Customer or Dealer's demonstration/rental fleet. Snorkel must be notified, in writing, within ten (10) days, of any machine sold to a Customer from a Dealer's rental fleet during the warranty period.
6. Any part or parts which upon examination by the Snorkel Product Support Department are found to be defective within the specified warranty period, will be replaced or repaired at the sole discretion of Snorkel, through Snorkel directly or an authorised Distributor, at no charge. Any parts replaced under warranty must be original Snorkel parts obtained through Snorkel directly or an authorised Distributor, unless expressly agreed otherwise in writing and in advance by Snorkel's Warranty Department.
7. All parts being claimed under warranty must be held available for return and inspection upon request for a period of 90 days from date of claim submission, it is necessary that all parts are individually tagged or marked with their part number and the warranty claim number. After 90 days all parts replaced under warranty which have not been returned to Snorkel should be destroyed. Failure to produce parts requested by the Warranty Administrator for inspection within a period of 14 days will result in the claim being automatically rejected in full. Materials returned for warranty inspection must have the following procedure:
  - Carefully packaged to prevent additional damage during shipping
  - Drained of all contents and all open ports capped or plugged
  - Shipped in a container tagged or marked with the RMA number
  - Shipped PREPAID. Any item(s) returned for warranty by any other means maybe refused and returned, unless prior approval is agreed with Snorkel.



## Product Warranty

8. At the direction of the Snorkel Warranty Department, any component part(s) of Snorkel products to be replaced or repaired under this warranty program must be returned freight prepaid for inspection. An RMA (Returns Material Authorisation) must be requested from Snorkel Warranty Department, a copy to be placed with the returning component part(s).
9. All warranty replacement parts will be shipped freight prepaid (standard charge) from the Snorkel Parts/Service Department or from the Vendor to Dealer or Customer.
10. All warranty claims are subject to approval by Snorkel Service Department. Snorkel reserves the right to limit or adjust claims with regard to defective parts, labor or travel time based on usual and customary guidelines.

### REPLACEMENT PARTS WARRANTY

- Any part replaced under this limited warranty is not subject to further warranty cover beyond the normal warranty period of the machine upon which the part was installed.
- Any replacement parts sold (not delivered under a warranty claim) will be subject to a warranty period of (6) six months from the date of invoice.
- Parts held by a Distributor are covered under warranty for a period of (12) twelve months from the date of invoice, provided that those parts have been subject to appropriate storage to prevent damage and deterioration.

### CLAIM PROCEDURE

The Snorkel Warranty Department must be notified within (48) forty-eight hours of any possible warranty situation during the applicable warranty period. Personnel performing major warranty repair or parts replacement must obtain specific approval by the Snorkel Warranty Department prior to performing the warranty repair or replacement.

When a Distributor/Customer perceive a warranty issue to exist the following steps must be adhered to:

- All warranty claims must be submitted within 30 days of the date of the machine repair
- All correspondence in respect of the claim to be on an official Snorkel warranty claim form as supplied by Snorkel's Warranty Department
- Allocate a warranty claim number to the repair
- Place a purchase order for genuine Snorkel replacement parts
- Snorkel to dispatch parts via the requested method (in line with the required response time)
- Confirmation that a qualified technician is available to replace the part and that this person has been accepted by Snorkel to carry out such work under the warranty of the machine. Failure to do this may nullify the warranty.

### FREIGHT DAMAGE

If a machine is received in a damaged condition, then the damage must be noted on the bill of lading and/or delivery documents and if possible photographs taken, prior to signing acceptance of the consignment. The freight company must be contacted by the Distributor and a damage claim registered immediately.

### THIS WARRANTY EXCLUDES AND SNORKEL DOES NOT WARRANT:

1. Engines, motors, tires and batteries are manufactured by suppliers to Snorkel, who furnish their own warranty. Snorkel will, however, to the extent permitted; pass through any such warranty protection to the Distributor/Customer.
2. Any Snorkel product which has been modified or altered outside Snorkel factory without Snorkel written approval, if such modification or alteration, in the sole judgment of Snorkel Engineering and/or Service Departments, adversely affects the stability, reliability or service life of the Snorkel product or any component thereof.



## Product Warranty

3. Any Snorkel product which has been subject to misuse and abuse, improper maintenance or accident. "Misuse" includes but is not limited to operation beyond the factory-rated load capacity and speeds. "Improper maintenance" includes but is not limited to failure to follow the recommendations contained in the Snorkel Operator's and Repair Parts Manuals.
4. Normal wear of any Snorkel component part(s). Normal wear of component parts may vary with the type, application or type of environment in which the machine may be used; such as, but not limited to sandblasting applications.
5. Routine maintenance, routine maintenance items and minor adjustments are not covered by this warranty, including but not limited to hydraulic fluid, filters and lubrication, paint and decals.
6. Any Snorkel product that has come into direct contact with any chemical or abrasive material.
7. Incidental or consequential expenses, losses, or damages related to any part or equipment failure, including but not limited to freight cost to transport the machine to a repair facility, downtime of the machine, lost time for workers, lost orders, lost rental revenue, lost profits, expenses or increased cost. This warranty is expressly in lieu of all other warranties, representations or liabilities of Snorkel, either expressed or implied, unless otherwise amended in writing by Snorkel.
8. Snorkel Warranty policy does not cover any duties, taxes, environmental fees including without limitation, disposal or handling of tires, batteries and petrochemical items.
9. Item specifically excluded are, fuel injectors, motor brushes, glow plugs, contactor tips and springs, oil filters, lamp bulbs, lamp lenses, O-rings, coolants, lubricants and cleaning material.
10. Failure of replacement parts due to fault misdiagnosis or incorrect fitting by the Distributor/Customer.

SNORKEL MAKES NO WARRANTIES WHICH EXTEND BEYOND THE DESCRIPTION OF THIS LIMITED WARRANTY

SNORKEL MAKES NO IMPLIED WARRANTY OF MERCHANTABILITY OR FITNESS FOR A PARTICULAR PURPOSE AND DISCLAIMS ALL LIABILITY FOR INCIDENTAL OR CONSEQUENTIAL DAMAGES, INCLUDING BUT NOT LIMITED TO INJURY TO PERSONS OR PROPERTY.

The Customer shall make all warranty claims through Snorkel directly or an Authorised Distributor. If unable to contact the Distributor, contact the Snorkel Service Department for further assistance.



# Product Warranty

## APPEAL

The buyer may appeal in writing against a rejected or adjusted claim to Snorkel Warranty Department within a period of 21 days of receiving the rejection or adjustment notice. The appeal should be grounded on express reasons and supported by relevant evidence. Appeals received outside of this time limit will not be considered.

## WARRANTY SCHEDULE

### Limited Warranty Periods

Item	Warranty Period
New machine materials and workmanship	1 year parts replacement
Structural components (Chassis, Turntable, Booms, Scissors)	5 years parts replacement or repair
Parts held in a Distributor's stock	12 months from date of invoice
Parts sold (non warranty)	6 months from date of invoice
Batteries	6 months from date of invoice
Other specifically excluded parts: Fuel injectors Motor brushes Glow plugs Contactor tips and springs Oils Filters Lamp bulbs Lamp lenses O-rings Coolants Lubricants Cleaning materials	Not covered by Warranty



**Local Distributor / Lokaler Vertiebshändler / Distributeur local  
El Distribuidor local / Il Distributore locale**

**EUROPE, MIDDLE EAST  
AFRICA & ASIA**

**PHONE:** +44 (0) 845 1550 058  
**FAX:** +44 (0) 845 1557 756

**NORTH & SOUTH AMERICA**

**PHONE:** +1 785 989 3000  
**TOLL FREE:** +1 800 255 0317  
**FAX:** +1 785 989 3070

**AUSTRALIA**

**PHONE:** +61 1300 700 450  
**FAX:** +61 2 9609 3057

**NEW ZEALAND**

**PHONE:** +64 6 3689 168  
**FAX:** +64 6 3689 164



[www.snorkellifts.com](http://www.snorkellifts.com)