

UpRight



LX50

WORK PLATFORMS

**Service &
Parts Manual**

SERVICE & PARTS MANUAL

LX50

Gasoline, Dual Fuel, and Diesel Models

Serial Numbers 2747 - current

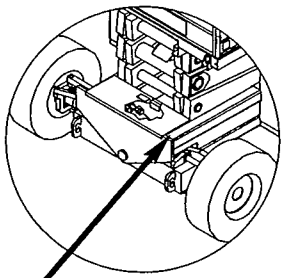

Stamped Serial
Number

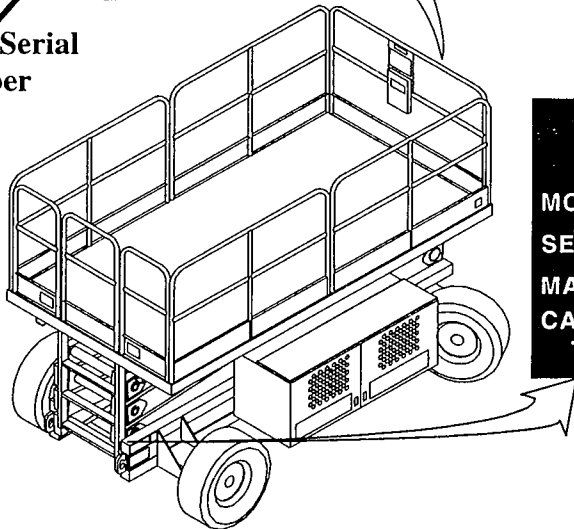

When contacting UpRight for service or parts information, be sure to include the MODEL and SERIAL NUMBERS from the equipment nameplate. Should the nameplate be missing, the SERIAL NUMBER is also stamped on top of the chassis above the front axle pivot.

UpRight, Inc.	
1775 PARK ST. SELMA, CA 93662 USA	
MODEL NO. <input type="text"/>	MAX. PLATFORM HEIGHT <input type="text"/>
SERIAL NO. <input type="text"/>	BATTERY VOLTAGE <input type="text"/>
MAX. DISTRIBUTED LOAD <input type="text"/>	<input type="text"/>
CAUTION: CONSULT OPERATOR'S MANUAL BEFORE USE. THIS PLATFORM IS NOT ELECTRICALLY INSULATED	
<small>P/N 61205-000-00</small>	

UpRight

Call Toll Free in U.S.A.

1-800-926-LIFT

UpRight, Inc.

1775 Park Street

Selma, California 93662

TEL: 559/891-5200

FAX: 559/891-9012

PARTS: 1-888-UR-PARTS

PARTSFAX: 559/896-9244

UpRight Ireland, Ltd.

Pottery Road

Dun Laoire,

Ireland

TEL: +353-1-202-4100

FAX: +353-1-202-4105

P/N 067904-005

5/99 .5k K

FORWARD

HOW TO USE THIS MANUAL

This manual is divided into 6 sections. The section number printed at the top corner of each page can be used as a quick reference guide.

SPECIAL INFORMATION

DANGER

Indicates the hazard or unsafe practice will result in severe injury or death.

WARNING

Indicates the hazard or unsafe practice could result in severe injury or death.

CAUTION

Indicates the hazard or unsafe practice could result in minor injury or property damage

NOTES: Give helpful information.

WORKSHOP PROCEDURES

CAUTION: Detailed descriptions of standard workshop procedures, safety principles and service operations are not included. Please note that this manual does contain warnings and cautions against some specific service methods which could cause personal injury, or could damage a machine or make it unsafe. Please understand that these warnings cannot cover all conceivable ways in which service, whether or not recommended by UpRight, Inc., might be done, or of the possible hazardous consequences of each conceivable way, nor could UpRight Inc. investigate all such ways. Anyone using service procedures or tools, whether or not recommended by UpRight Inc., must satisfy themselves thoroughly that neither personal safety nor machine safety will be jeopardized.

All information contained in this manual is based on the latest product information available at the time of printing. We reserve the right to make changes at any time without notice. No part of this publication may be reproduced, stored in retrieval system, or transmitted, in any form by any means, electronic, mechanical, photocopying, recording, or otherwise, without the prior written permission of the publisher. This includes text, figures and table.

Introduction & Specifications

General description and machine specifications.

1.0

Machine Preparation & Operation

Information on how to operate the work platform and how to prepare it for operation.

2.0

Maintenance

Preventative maintenance and service information.

3.0

Troubleshooting

Causes and solutions to typical problems.

4.0

Schematics

Schematics and valve block diagram with description and location of components.

5.0

Illustrated Parts Breakdown

Complete parts lists with illustrations.

6.0

FORWARD

Notes:

TABLE OF CONTENTS

SECTION 1

Introduction & Specifications	1-1
1.1 Introduction	1-1
Purpose	1-1
Scope	1-1
1.2 General Description	1-1
Platform	1-1
Controller	1-1
Elevating Assembly	1-1
Power Module	1-1
Control Module	1-1
Chassis	1-1
Purpose of Equipment	1-2
Special Limitations	1-2
1.3 Specifications	1-3
Notes:	1-4

SECTION 2

Machine Preparation & Operation	2-1
2.1 Preparation for Use	2-2
2.2 Transporting Work Platform	2-2
By Crane	2-2
By Truck	2-2
2.3 Preparation for Shipment	2-2
2.4 Storage	2-3
Preservation	2-3
Battery	2-3
2.5 Design Features	2-3
2.6 Controls and Indicators	2-4
2.7 Safety Rules and Precautions	2-6
2.8 Pre-Operation Inspection	2-6
System Function Inspection	2-7
2.9 Operation	2-8
Travel With Platform Lowered	2-8
Steering	2-8
Leveling the Platform	2-8
To Retract the outriggers	2-9
Raising and Lowering the Platform	2-9
Travel with Work Platform Elevated	2-9
Emergency Lowering	2-9
Switching Fuels (Dual Fuel Only)	2-9
After Use Each Day	2-9
2.10 Parking Brake Release	2-9
2.11 Fold Down Guardrails	2-10
Fold Down Procedure	2-10
Erection Procedure	2-10

SECTION 3

Maintenance	3-1
3.1 Introduction	3-1
3.2 Date Code Identification on Hoses ..	3-1
3.3 Special Tools	3-1
Deutsch Connectors	3-2
Male Connector (Plug)	3-2
Female Connector (Receptacle)	3-2
Releasing Locking Fingers	3-2
Crimping	3-3
Removing Contact	3-3
3.4 Preventative Maintenance	3-3
Preventative Maintenance Table Key ..	3-4
Interval	3-4
Preventative Maintenance Report	3-4
3.5 Blocking Elevating Assembly	3-5
Installation	3-5
Removal	3-5
3.6 Battery Maintenance	3-5
Battery Inspection and Cleaning	3-5
3.7 Lubrication	3-6
Grease Fittings	3-6
Steering Linkage	3-6
Torque Hubs	3-6
Hydraulic Oil Tank and Filter	3-6
Fluid Level	3-6
Oil and Filter Replacement	3-7
Engine Oil & Filter	3-7
3.8 Setting Hydraulic Pressures	3-8
Pump Setup	3-8
Lift Relief Valve	3-8
Counterbalance Valves	3-8
Steering Relief Valves	3-9
Bidirectional Relief Valves	3-9

TABLE OF CONTENTS

<p>3.9 Switch Adjustments 3-10</p> <p style="padding-left: 20px;">Proportional Control Adjustment 3-10</p> <p style="padding-left: 20px;">Procedure 3-10</p> <p style="padding-left: 20px;">Platform Down Limit Switches 3-11</p> <p style="padding-left: 20px;">Axle Center Switch 3-11</p> <p style="padding-left: 20px;">Tilt Sensor 3-12</p> <p>3.10 Hydraulic Manifold 3-12</p> <p style="padding-left: 20px;">Removal 3-12</p> <p style="padding-left: 20px;">Disassembly 3-12</p> <p style="padding-left: 20px;">Cleaning and Inspection 3-12</p> <p style="padding-left: 20px;">Assembly 3-12</p> <p style="padding-left: 20px;">Installation 3-12</p> <p>3.11 Hydraulic Pump 3-14</p> <p style="padding-left: 20px;">Removal 3-14</p> <p style="padding-left: 20px;">Installation 3-14</p> <p>3.12 Hydraulic Brakes, Drive Motors, And Hubs 3-14</p> <p style="padding-left: 20px;">Rear Axle Removal 3-14</p> <p style="padding-left: 20px;">Installation 3-15</p> <p style="padding-left: 20px;">Seal Replacement 3-15</p> <p style="padding-left: 20px;">Seal Replacement, Rear Motor 3-16</p> <p style="padding-left: 20px;">Front Axle 4WD 3-18</p> <p style="padding-left: 20px;">Removal 3-18</p> <p style="padding-left: 20px;">Installation 3-18</p> <p style="padding-left: 20px;">Seal Replacement, Front Motor 3-20</p> <p>3.13 Axle Cylinder (4WD Only) 3-22</p> <p style="padding-left: 20px;">Removal 3-22</p> <p style="padding-left: 20px;">Seal Replacement 3-22</p> <p style="padding-left: 20px;">Installation 3-22</p>	<p>3.14 Steering Cylinder 3-24</p> <p style="padding-left: 20px;">Removal 3-24</p> <p style="padding-left: 20px;">Seal Replacement 3-24</p> <p style="padding-left: 20px;">Installation 3-24</p> <p>3.15 Lift Cylinders 3-26</p> <p style="padding-left: 20px;">Removal 3-26</p> <p style="padding-left: 20px;">Seal Replacement 3-26</p> <p style="padding-left: 20px;">Installation 3-27</p> <p>3.16 Outrigger Cylinder 3-28</p> <p style="padding-left: 20px;">Removal 3-28</p> <p style="padding-left: 20px;">Seal Replacement 3-28</p> <p style="padding-left: 20px;">Installation 3-28</p> <p>3.17 Engine Adjustments 3-30</p> <p style="padding-left: 20px;">Gasoline Engine 3-30</p> <p style="padding-left: 40px;">Idle Speed 3-30</p> <p style="padding-left: 40px;">Governed High Speed 3-30</p> <p style="padding-left: 20px;">Diesel Engine 3-30</p> <p style="padding-left: 40px;">Idle Speed 3-30</p> <p style="padding-left: 40px;">High Speed 3-30</p> <p style="padding-left: 20px;">Propane Engine 3-31</p> <p style="padding-left: 40px;">Leak Idle Adjustment 3-31</p> <p style="padding-left: 40px;">Load Screw Adjustment 3-31</p> <p>3.18 Filter Replacement 3-31</p> <p style="padding-left: 20px;">Gasoline/Propane Engine 3-31</p> <p style="padding-left: 40px;">Air Filter Element 3-31</p> <p style="padding-left: 40px;">Fuel Filter 3-31</p> <p style="padding-left: 20px;">Diesel Engine 3-32</p> <p style="padding-left: 40px;">Air Filter Element 3-32</p> <p style="padding-left: 40px;">Fuel Filter 3-32</p> <p>3.19 Torque Specifications 3-33</p> <p style="padding-left: 20px;">Fasteners 3-33</p> <p style="padding-left: 20px;">Hydraulic Components 3-33</p>
---	---

SECTION 4

<p>Troubleshooting 4-1</p> <p style="padding-left: 20px;">4.1 Introduction 4-1</p> <p style="padding-left: 40px;">General Procedure 4-1</p>	<p>4.2 Electrical Truth Tables 4-2</p> <p>4.3 Hydraulic Truth Tables 4-10</p>
---	---

SECTION 5

<p>Schematics 5-1</p> <p style="padding-left: 20px;">5.1 Introduction 5-1</p> <p style="padding-left: 20px;">5.1 Electrical Schematic 5-2</p> <p style="padding-left: 20px;">5.2 Electrical Schematic 5-6</p> <p style="padding-left: 20px;">5.3 Electrical Schematic 5-10</p> <p style="padding-left: 20px;">5.4 Electrical Schematic 5-14</p> <p style="padding-left: 20px;">5.5 Hydraulic Schematic 5-18</p>	<p>5.6 Hydraulic Schematic 5-20</p> <p>5.7 Hydraulic Schematic 5-22</p> <p>5.8 Hydraulic Schematic 5-24</p> <p style="padding-left: 20px;">5.2 Electrical Schematic 5-6</p> <p style="padding-left: 20px;">5.3 Electrical Schematic 5-10</p> <p style="padding-left: 20px;">5.4 Electrical Schematic 5-14</p>
--	---

SECTION 6

<p>Illustrated Parts Breakdown 6-1</p>	
---	--

LIST OF FIGURES

SECTION 1

Introduction & Specifications

Figure 1-1: LX50 Work Platform1-2

SECTION 2

Machine Preparation & Operation

Figure 2-1: Battery2-2

Figure 2-2: Transporting Work Platform2-2

Figure 2-3: Controls & Indicators2-5

Figure 2-4: Fold Down Guardrails2-10

SECTION 3

Maintenance

Figure 3-1: Deutsch Connector Kit, Small3-1

Figure 3-2: Deutsch Connector Kit, Large3-1

Figure 3-3: Deutsch Connectors3-2

Figure 3-4: Locking Finger, Deutsch Conn. ...3-2

Figure 3-5: Heavy Duty Deutsch Connector ...3-3

Figure 3-6: Blocking Elevating Assembly3-5

Figure 3-7: Lubrication Chart3-6

Figure 3-8: Hydraulic Oil Tank & Filter3-7

Figure 3-9: Engine Oil Filter3-7

Figure 3-10: Hydraulic Pump3-8

Figure 3-11: Flow Meter Setup3-9

Figure 3-12: Valve Manifold3-10

Figure 3-13: Proportional Controller3-10

Figure 3-14: Platform Down Limit Switch3-11

Figure 3-15: Axle Center Switch3-11

Figure 3-16: Tilt Sensor3-12

Figure 3-17: Hyd. Manifold, Exploded View...3-13

Figure 3-18: Hydraulic Pump3-14

Figure 3-19: Rear Axle assembly3-14

Figure 3-20: Brake Assembly3-15

Figure 3-21: Rear Drive Motor Assembly3-17

Figure 3-22: Front Axle Assembly, 4WD3-18

Figure 3-23: Front Drive Motor Assembly3-19

Figure 3-24: Front Drive Motor Assy, Details .3-21

Figure 3-25: Floating Axle Assembly3-23

Figure 3-26: Axle Float Cyl. Cross Section ...3-23

Figure 3-27: Front Axle Assembly, 4WD3-25

Figure 3-28: Steering Cylinder Cross Section 3-25

Figure 3-29: Lift Cylinder Cross Section3-27

Figure 3-30: Outrigger Cylinder Installation ..3-29

Figure 3-31: Outrigger Cylinder Cross Section 3-29

Figure 3-32: Gasoline Engine Carburetor3-30

Figure 3-33: Gasoline Engine Governor3-30

Figure 3-34: Diesel Engine3-30

Figure 3-35: Gasoline Engine Air Filter3-31

Figure 3-36: Gasoline Engine Fuel Filter3-31

Figure 3-37: Diesel Engine Air Filter3-32

Figure 3-38: Diesel Engine Fuel Filter3-32

LIST OF FIGURES

SECTION 5

Schematics

Figure 5-1: Electrical Schematic: Two Wheel Drive, Dual Fuel - 067535-054 (1 of 2)	5-4
Figure 5-2: Electrical Schematic: Two Wheel Drive, Dual Fuel - 067535-054 (2 of 2)	5-5
Figure 5-3: Electrical Schematic: Two Wheel Drive, Diesel - 067535-055 (1 of 2)	5-8
Figure 5-4: Electrical Schematic: Two Wheel Drive, Diesel - 067535-055 (2 of 2)	5-9
Figure 5-5: Electrical Schematic: Four Wheel Drive, Dual Fuel - 067535-056 (1 of 2)	5-12
Figure 5-6: Electrical Schematic: Four Wheel Drive, Dual Fuel - 067535-056 (2 of 2)	5-13
Figure 5-7: Electrical Schematic: Four Wheel Drive, Diesel - 067535-057 (1 of 2)	5-16
Figure 5-8: Electrical Schematic: Four Wheel Drive, Diesel - 067535-057 (2 of 2)	5-17
Figure 5-9: Electrical Schematic: Outrigger Option (1 of 3)	5-19
Figure 5-10: Electrical Schematic: Outrigger Option (2 of 3)	5-20
Figure 5-11: Electrical Schematic: Outrigger Option (3 of 3)	5-21
Figure 5-12: Hydraulic Schematic: Two Wheel Drive (067534-014)	5-19
Figure 5-13: Hydraulic Schematic: Four Wheel Drive (067534-015)	5-21
Figure 5-14: Hydraulic Schematic: Two Wheel Drive w/ outriggers (067534-016)	5-23
Figure 5-15: Hydraulic Schematic: Four Wheel Drive w/ outriggers (067534-017)	5-25

LIST OF TABLES

SECTION 1

Introduction & Specifications

Table 1-1: Specifications	1-3
---------------------------------	-----

SECTION 2

Machine Preparation & Operation

Table 2-1: Controls and Indicators	2-4
--	-----

SECTION 3

Maintenance

Table 3-1: Preventative Maintenance Check list	3-4
Table 3-2: Engine Oil	3-7
Table 3-3: Torque Specifications for Fasteners	3-33
Table 3-4: Torque Specifications for Hydraulic Components	3-33

SECTION 4

Troubleshooting

Table 4-1: Electrical Truth Table - Dual Fuel Models (2wd: 067535-054, 4wd: 067535-056)	4-2
Table 4-2: Electrical Truth Table - Diesel Models (2wd: 067535-055, 4wd: 067535-057) ...	4-6
Table 4-3: Hydraulic Truth Table - Two Wheel Drive Model (067534-014)	4-10
Table 4-4: Hydraulic Truth Table - Four Wheel Drive Model (067534-015)	4-11
Table 4-5: Hydraulic Truth Table - Two Wheel Drive Model w/ Outriggers (067534-016) ..	4-12
Table 4-6: Hydraulic Truth Table - Four Wheel Drive Model w/ Outriggers (067534-017) .	4-13

SECTION 5

Schematics

Table 1: Electrical Schematic Legend: Two Wheel Drive, Dual Fuel Model (067535-054) .	5-2
Table 2: Electrical Schematic Legend: Two Wheel Drive, Diesel Model (067535-055)	5-6
Table 3: Electrical Schematic Legend: Four Wheel Drive, Dual Fuel Model (067535-056) .	5-10
Table 4: Electrical Schematic Legend: Four Wheel Drive, Diesel Model (067535-057) ...	5-14
Table 5: Electrical Schematic Legend: Outrigger Option	5-18
Table 5: Two Wheel Drive Models (067534-014)	5-22
Table 6: Four Wheel Drive Models (067534-015)	5-24
Table 7: Two Wheel Drive Models w/Outriggers (067534-016)	5-26
Table 8: Four Wheel Drive Models w/Outriggers (067534-017)	5-28

LIST OF TABLES

NOTES:

Section 1

INTRODUCTION & SPECIFICATIONS

1.1 INTRODUCTION

Purpose

The purpose of this service and parts manual is to provide instructions and illustrations for the operation and maintenance of the LX50 Work Platform manufactured by UpRight, Inc. of Selma, California.

Scope

The manual includes procedures for proper operation, maintenance, adjustment, and repair of this product as well as recommended maintenance schedules and troubleshooting.

1.2 GENERAL DESCRIPTION

The LX50 Work Platform consists of the platform, controller, elevating assembly, power module, control module, and chassis.

Platform

The platform has a reinforced steel floor, 43.5 inch (1.11 m) high guardrails with midrail, 6 inch (152 mm) toeboards and an entrance gate at the rear of the platform. The guardrails can be folded down for access through doors or for shipment.



WARNING



DO NOT use the maintenance platform without guardrails properly assembled and in place.

Controller

The controller contains the controls to operate the machine. It should be hung on the front, left, or right guardrail, but may be hand held if necessary. To operate the machine, the interlock lever must be depressed to operate any function. A complete explanation of control functions can be found in Section 2.

Elevating Assembly

The platform is raised and lowered by the elevating assembly; a five section scissor assembly powered by two single-stage lift cylinders. The hydraulic pump, driven by the engine, powers the cylinder. Solenoid operated valves control raising and lowering.

Power Module

The power module contains the engine, hydraulic pump, hydraulic reservoir, and starter solenoid.

Control Module

The control module contains the L.P. bottle and/or fuel tank, hydraulic valve manifold, horn/alarms, volt/hour meter, electrical terminal strips, battery, and chassis control panel. A complete explanation of the chassis control functions is found in Section 2.

Chassis

The chassis is a structural frame that supports all the components of the LX50 Work Platform.

Purpose of Equipment

The objective of the LX50 Work Platform is to provide a quickly deployable, self propelled, variable height work platform to elevate personnel and materials to overhead work areas and be driven over rough terrain (4WD model only).

Special Limitations

Travel with the platform raised is limited to a creep speed range.

Elevating of the Work Platform is limited to firm, level surfaces only. Any degree of slope greater than 3° will lockout the elevating circuits and sound a warning alarm.

FOUR WHEEL MODELS: driving while elevated is limited to flat surfaces only. Machine must be level and Front and Rear Axles must be parallel

⚠ DANGER ⚠

The elevating function shall ONLY be used when the work platform is level and on a firm surface. The work platform is NOT intended to be driven over uneven, rough or soft terrain when elevated.

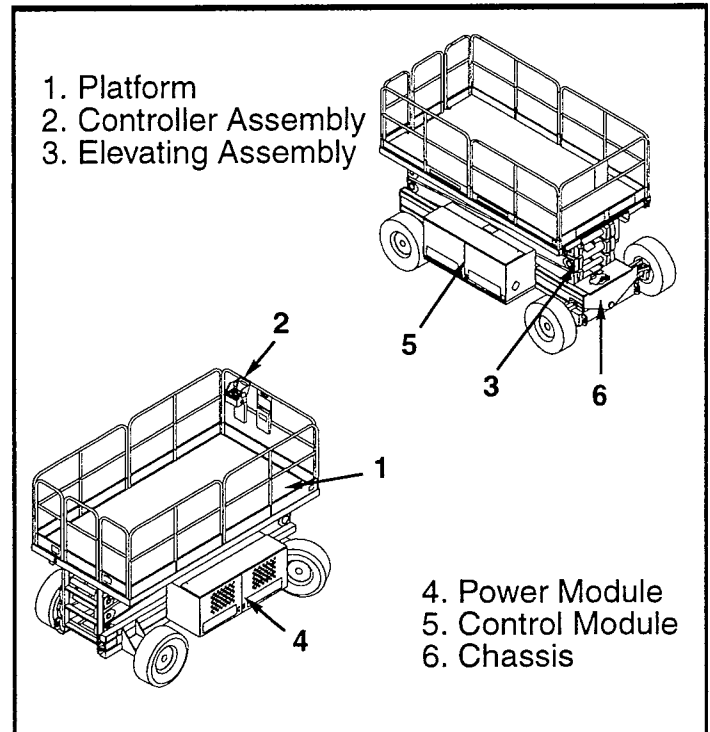

Figure 1-1: LX50 Work Platform

1.3 SPECIFICATIONS

Table 1-1: Specifications

Specifications are subject to change without notice

Meets or exceeds all applicable requirements of OSHA and ANSI A92.6-1999

ITEM	LX50
Platform Size (inside toeboards)	
Standard	143 3/8 in x 70 in. [3,64 m x 1,78 m]
Slide Out Deck Extended	179 3/8 in. x 68 in. [4,57 m x 1,73]
Max. Platform Capacity	
Standard	1,000 lbs. [454 kg]
w/ Extension	1,000 lbs. [454 kg], on Extension 500 lbs. [227 kg]
w/ Dual Deck	750 lbs [340 kg]. on Extension 500 lbs. [227 kg]
Max. No. of occupants	
Standard	4 people
on Extension	2 people
Height	
Working Height	56 ft. [17,09 m]
Max. Platform Height	49 ft. 6 in. [15,09 m]
Min. Platform Height	76 in. [1,93 m]
Drivable Height	49 ft. 6 in. [15,09 m]
Dimensions	
Weight, Standard	2WD: 12,220 lbs. [5,534 kg] 4WD: 12,480 lbs. [5,656 kg]
Weight, w/extension	2WD: 12,690 lbs. [5,756 kg] 4WD: 12,960 lbs. [5,879 kg]
Overall Width	90 in. [2,29 m]
Overall Height	118.25 in. [3 m]
Overall Length, Standard	160.5 in. [4,08 m]
Surface Speed	
Platform Lowered	0 to 3.1 mph [0 to 5,0 km/h]
Platform Raised	0 to 0.3 mph [0 to 0,48 km/h]
System Voltage	
	12 Volt DC
Hydraulic Tank Capacity	
	28.3 US Gallons [107.13 l]
Maximum Hydraulic System Pressure	
	3000 psi [206,8 bar]
Hydraulic Fluid	
Normal use, above 32° F [0° C]	ISO #46
Low Temp. Use, below 32° F [0° C]	ISO #32
Extreme Temp. Use, below 0° F [-17° C]	ISO #15
Lift System	
	Two Single Stage Lift Cylinders
Lift Speed	
	Raise, 45 sec./Lower, 65 sec.
Platform Leveling	
	8.5° (12 in. [.3m]) Side/Side, 6° (12 in. [.3m]) Fore/Aft
Power Source	
	Diesel or Gasoline 20 HP Kubota, 3 Cylinder, Water Cooled
Drive Control	
	Proportional
Control System	
	Joystick Controller with Interlock Lever and Thumb Rocker Steering; Speed & Function Selector Switches and Emergency Stop Button
Horizontal Drive	
	2WD: 2 Wheel, Hyd. Motors 4WD: 4 Wheel, Hyd. Motors
Air Filled Tires	
	10-16.5 NHS 8 Ply, 50psi. [3,4 bar]
Parking Brakes	
	Two, Spring Applied, Hydraulic Release, Multiple Disc
Turning Radius (inside)	
	48 in. [1,22 m]
Maximum Gradeability	
	2wd: 30% [16,7°] 4wd: 24% [13,5°]
Wheel Base	
	115.75 in. [2,94 m]
Guardrails	
	43.5 in. [1.1 m] high, Fold Down with gate.
Toeboard	
	6 in. [152 mm] High

Notes:

Section 2

MACHINE PREPARATION & OPERATION

Warning

All personnel shall carefully read, understand and follow all safety rules, operating instructions, and the Scaffold Industry Association's *Manual of Responsibilities (ANSI A92.6)* before operating or performing maintenance on any Upright aerial work platform.

Safety Rules

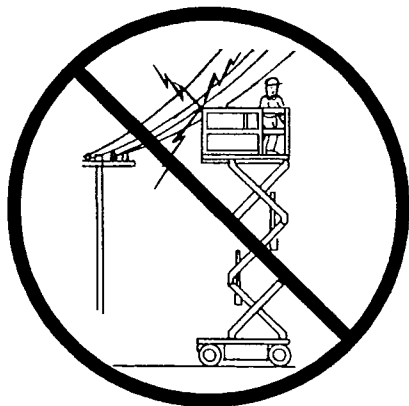

NEVER operate the machine within ten feet of power lines.
THIS MACHINE IS NOT INSULATED.

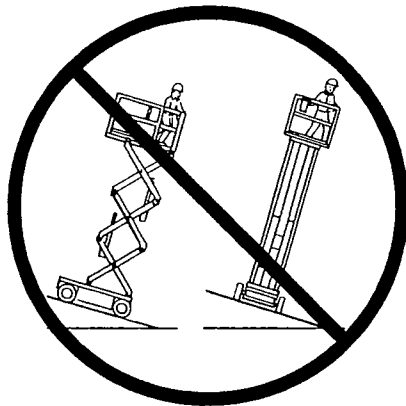

NEVER elevate or drive elevated on uneven slopes or soft ground or elevate the platform unless the platform is level.

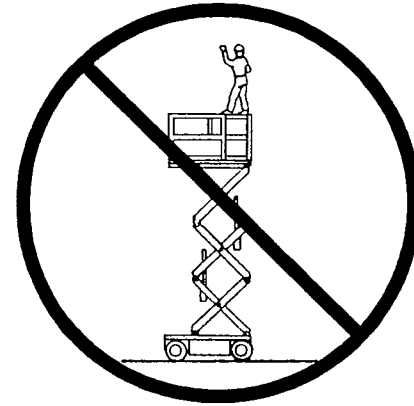

NEVER sit, stand or climb on guardrail or midrail.

NEVER operate the machine without first surveying the work area for surface hazards such as holes, drop-offs, bumps and debris.

NEVER operate the machine if all guardrails are not properly in place and secured with all fasteners properly torqued.

SECURE and lock gate after mounting platform.

KEEP all body parts clear of outriggers when extending or retracting (outrigger equipped machines only).

NEVER use ladders or scaffolding on the platform.

NEVER attach overhanging loads or increase platform size.

LOOK up, down and around for overhead obstructions and electrical conductors.

DISTRIBUTE all loads evenly on the platform. See the back cover for maximum platform load.

NEVER use damaged equipment. (Contact UpRight for instructions. See toll-free phone number on back cover.)

NEVER change operating or safety systems.

INSPECT the machine thoroughly for cracked welds, loose hardware, hydraulic leaks, damaged control cable, loose wire connections and wheel bolts.

NEVER climb down elevating assembly with the platform elevated.

NEVER perform service on machine while platform is elevated without blocking elevating assembly.

NEVER recharge battery near sparks or open flame; batteries that are being charged emit highly explosive hydrogen gas.

AFTER USE secure the work platform against unauthorized use by turning key switch off and removing key.

NEVER replace any component or part with anything other than original UpRight replacement parts without the manufacturer's consent.

California Proposition 65 Warning

Gasoline and diesel engine exhaust and some of their constituents are known to the State of California to cause cancer, birth defects, and other reproductive harm.

NOTE: Read and familiarize yourself with all operating instructions before attempting to operate the LX50 Work Platform.

2.1 PREPARATION FOR USE

⚠ CAUTION ⚠

STAND CLEAR when cutting the metal banding to avoid being cut if the banding snaps back.

1. Remove the metal banding from the module covers and elevating linkage.
2. Remove the banding from the control console.
3. Remove tie wraps holding guardrail gate.
4. Connect the negative (-) lead to the negative (-) battery terminal in power module (Figure 2-1).

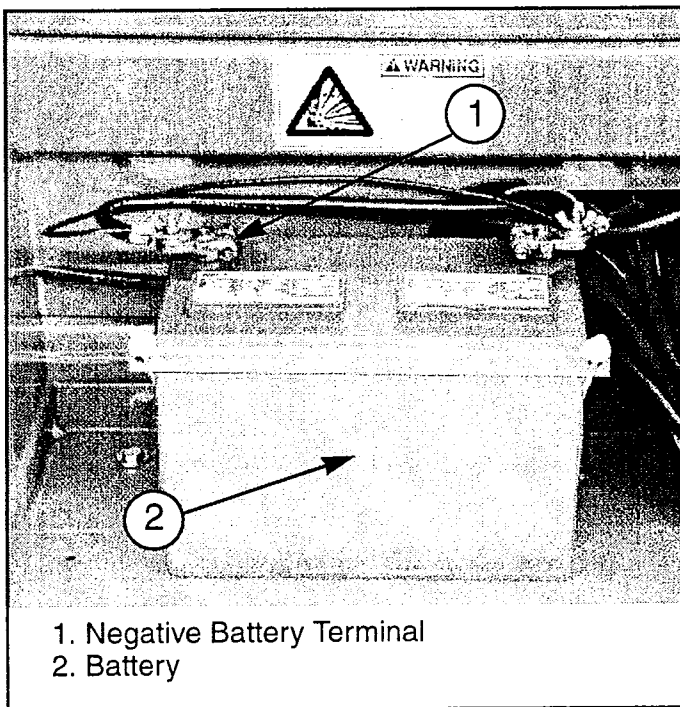

Figure 2-1: Battery

2.2 TRANSPORTING WORK PLATFORM

By Crane

1. Secure straps to chassis tie down/lifting lugs only (Figure 2-2).

By Truck

1. Maneuver the work platform into transport position and chock wheels.
2. Secure the work platform to the transport vehicle with chains or straps of adequate load capacity attached to the chassis tie down/lifting lugs.

⚠ CAUTION ⚠

Overtightening of chains or straps through tie down lugs may result in damage to work platform.

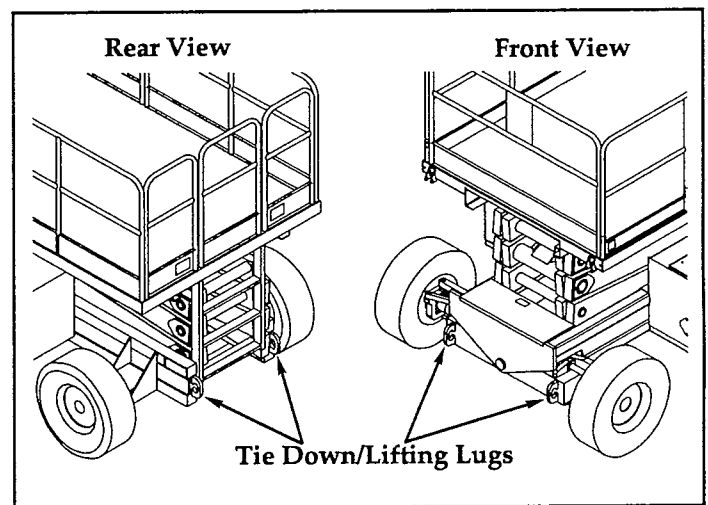

Figure 2-2: Transporting Work Platform

2.3 PREPARATION FOR SHIPMENT

1. Grease all the grease fittings. (See Section 3)
2. Fully lower the platform.
3. Disconnect the battery negative (-) lead from the battery terminal Figure 2-1.
4. Band the controller to the front guardrail.
5. Band the elevating linkage to the frame.

2.4 STORAGE

No preparation for storage is required when the work platform is in normal usage. Regular maintenance procedures should continue to be performed (see Figure 3-1 & Table 3-1).

If the work platform is to be placed in long term storage (dead storage), follow the recommended preservation procedures, below.

Preservation

1. Clean painted surfaces. If the paint is damaged, repaint.
2. Fill the hydraulic tank to operating level, fluid will be visible at the Sight Gauge. DO NOT fill the hydraulic tank while the platform is elevated.

NOTE: DO NOT drain the hydraulic system prior to long term storage.

3. Coat exposed portions of extended cylinder rods with a preservative such as multipurpose grease and wrap with barrier material.
4. Coat all exposed unpainted metal surfaces with preservative.
5. Service the engine according to the manufacturers recommendations.

Battery

1. Disconnect the battery negative (-) cable and secure to the chassis.
2. Disconnect the remaining battery leads and secure to the chassis.
3. Remove the battery and place in alternate service

2.5 DESIGN FEATURES

The LX50 has the following features to insure safe operation:

1. The Lift Valve will not energize unless the chassis is level.
2. The Floating Front Axle locks in position upon elevating the work platform.
3. A warning alarm sounds and Drive Valves are de-energized if the work platform should become unlevel while elevated.
4. A motion alarm sounds when the work platform is lowering.
5. The platform descent rate is controlled by an orifice. The Lift Cylinder is equipped with a holding valve to prevent descent should a leak develop.
6. The drive speed is limited to "creep" speed when operating the work platform while elevated.
7. Drive will not operate while elevated unless the Floating Front Axle is positioned parallel to the Rear Axle.
8. Holding brakes are automatically engaged when the Drive Valves are de-energized from the Controller or from a loss of power.
9. The Platform and Chassis controls are each equipped with an Emergency Stop Switch.
10. Up and Down Buttons are located in the Control Module on the chassis for lifting and lowering the work platform from ground level.
11. The Down Valve can be operated manually by means of a cable linkage in the event of powered function failure.
12. Dynamic braking, and runaway protection are provided by the use of Counterbalance Valves in the drive system.
13. A Level Sensor is used to sense when the machine is unlevel, disabling lift functions, and drive when elevated.
14. Drive is disabled when Outriggers are deployed.
15. When using Outriggers, lift is disabled if Outriggers are not taking load.

2.6 CONTROLS AND INDICATORS

The controls and indicators for operation of the LX50 Work Platform are shown in Figure 2-3. The name and function of each control and indicator are listed in Table 2-1. The index numbers in Figure 2-3 correspond to the index numbers in Table 2-1. The

operator shall know the location of each control and indicator and have a thorough knowledge of the function and operation of each before attempting to operate the unit.

Table 2-1: Controls and Indicators
Controller/Platform

Chassis

INDEX #	NAME	FUNCTION	INDEX #	NAME	FUNCTION
1	KEY SWITCH	Turn key fully clockwise to start engine, when released key goes to RUN to provide power to the Interlock Switch.	12	HOURMETER (optional)	Tracks the number of hours of engine powered operation.
2	EMERGENCY STOP SWITCH	Push red button to cut power to all controls (off). Turn clockwise to provide power (on).	13	RAISE BUTTON	Press button to lift the platform and
3	CONTROL LEVER	Move joystick forward or backwards to control Drive and Lift Valves proportionally or Down Valve depending on position of Drive Lift Switch.	14	LOWER BUTTON	Press button to lower the platform.
4	STEERING SWITCH	Moving the momentary rocker switch Right or Left steers the work platform in that direction. Although the Steering Switch is self centering the steering system is not. The wheels must be steered back to straight.	15	EMERGENCY STOP SWITCH	Push red button to cut power to all controls (off). Turn clockwise to provide power (on).
5	DRIVE SPEED/TORQUE SELECTOR SWITCH	Provides two speed/torque ranges, in forward or reverse. High Speed -low torque and High Torque -low speed.	16	FUEL SELECTOR SWITCH (Dual Fuel Only)	Turning switch left or right changes the engine's fuel supply between Gasoline and Propane. Placing the switch in the center position purges the fuel lines prior to changing fuels.
6	DRIVE/LIFT SWITCH	Selecting Drive allows the work platform to move forward or reverse. Selecting Lift allows the work platform to raise or lower.	17	EMERGENCY LOWERING VALVE	Pull out to lower the platform in the event of powered function failure.
7	INTERLOCK LEVER SWITCH	Provides power to the Controller powered functions, only when depressed, preventing accidental activation of the Controller.	18	DOWN ALARM*	Sounds an audible signal while platform is lowering during normal operation. If the Emergency Lowering Valve is used the alarm does not sound.
8	DRIVE ENABLE INDICATOR	Illuminates when drive is enabled, turns off when disabled.		TILT ALARM*	Sounds an audible signal when the platform is elevated and on a slope of 2° side to side or fore and aft.
9	OUTRIGGER SWITCHES	Push up to extend Outriggers, down to retract them.	19	BRAKE RELEASE PUMP	Releases the Parking Brake allowing the machine to be moved in the event power is lost or for winching onto a trailer. See Section 3.5.
10	ORBIT LEVEL	Use when leveling machine with Outriggers.	20	START BUTTON	Press to start the engine. Release after engine starts.
11	CHOKE BUTTON (gasoline / dual fuel)	Press to engage choke when starting engine.	21	STOP BUTTON	Press to kill the engine.
	GLOW PLUG BUTTON (diesel)	Press and hold for 6 seconds to preheat glow plugs before starting.	22	THROTTLE BUTTON	Press to increase engine RPM when operating functions from the lower control panel.
			23	PLATFORM / CHASSIS SWITCH	Turn switch to the left to enable platform controls. Turn switch to the right to enable chassis controls.
			24	CHOKE BUTTON (gasoline / dual fuel)	Press to engage choke when starting engine.
				GLOW PLUG BUTTON (diesel)	Press and hold for 6 seconds to preheat glow plugs before starting.

* Down Alarm and Tilt Alarm are the same unit with different inputs.

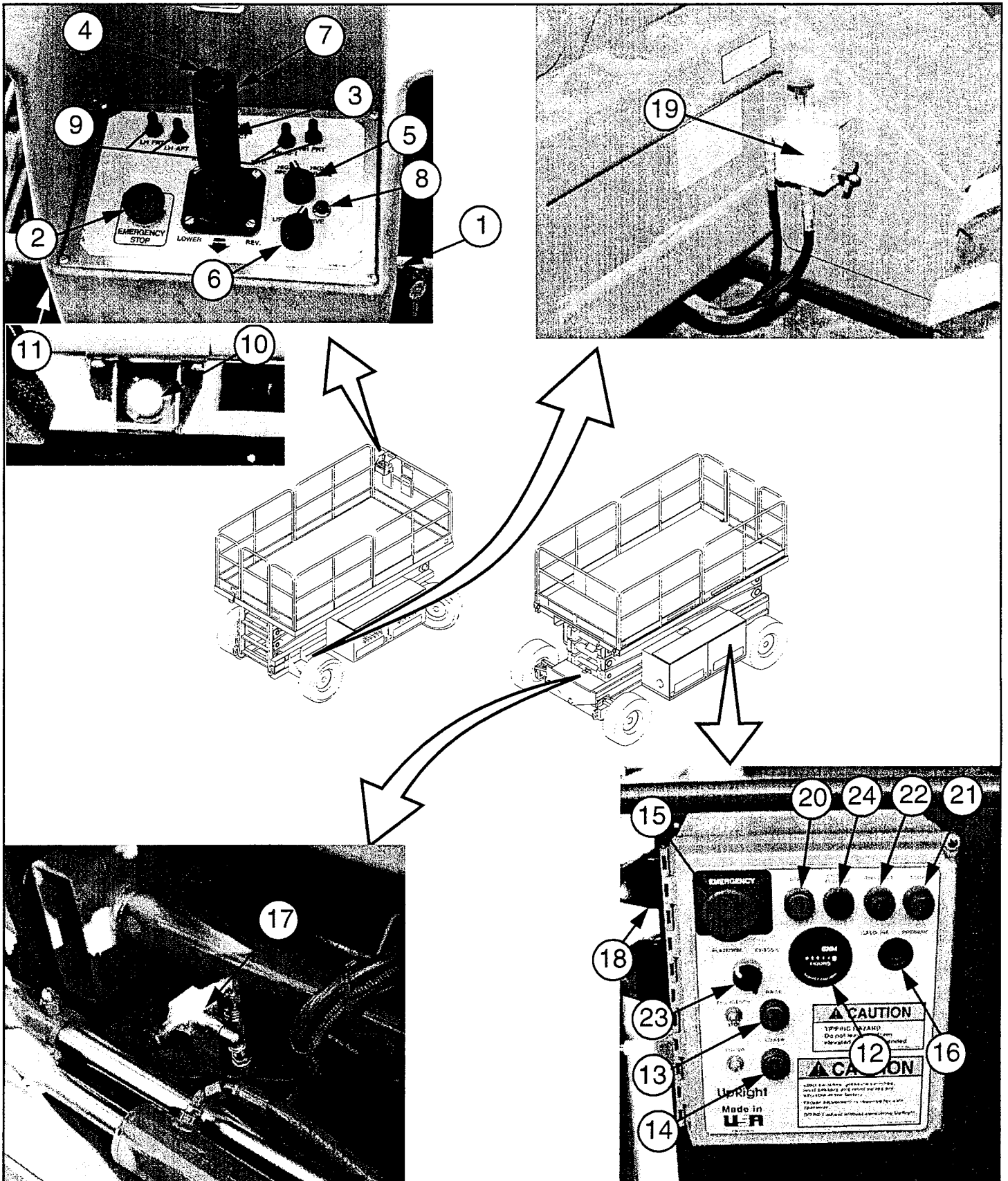

Figure 2-3: Controls & Indicators

2.7 SAFETY RULES AND PRECAUTIONS

ALWAYS observe the following safety rules and precautions when using the LX50 Work Platform:

NEVER operate the machine within ten feet of power lines. **THIS MACHINE IS NOT INSULATED.**

NEVER elevate the platform or drive the machine while elevated unless the machine is on firm level surface.

NEVER sit, stand or climb on guardrail or midrail.

NEVER operate the machine without first surveying the work area for surface hazards such as holes, drop-offs, bumps and debris.

NEVER operate the machine if all guardrails are not properly in place and secured with all fasteners properly torqued.

SECURE and lock gate after mounting platform.

KEEP all body parts clear of outriggers when extending or retracting.

NEVER use ladders or scaffolding on the platform.

NEVER attach overhanging loads or increase platform size.

LOOK up, down and around for overhead obstructions and electrical conductors.

DISTRIBUTE all loads evenly on the platform. See the back cover for maximum platform load.

NEVER use damaged equipment. (Contact UpRight for instructions. See toll-free phone number on back cover.)

NEVER change operating or safety systems.

INSPECT the machine thoroughly for cracked welds, loose hardware, hydraulic leaks, damaged control cable, loose wire connections and wheel bolts.

NEVER climb down elevating assembly with the platform elevated.

NEVER perform service on machine while platform is elevated without blocking elevating assembly.

NEVER recharge battery near sparks or open flame; batteries that are being charged emit highly explosive hydrogen gas.

AFTER USE secure the work platform against unauthorized use by turning key switch off and removing key.

NEVER replace any component or part with anything other than original UpRight replacement parts without the manufacturer's consent.

ALWAYS read, understand, and follow all safety rules and operating instructions, and the Scaffold Industry Association's **MANUAL OF RESPONSIBILITIES** (ANSI/SIA A92.6-1990) before operating or performing maintenance on any UpRight self propelled aerial work platform.

2.8 PRE-OPERATION INSPECTION

NOTE: Carefully read, understand and follow all safety rules, operating instructions, labels and the Scaffold Industry Association's **MANUAL OF RESPONSIBILITIES**. Perform the following steps each day before use.

1. Open modules and inspect for damage, oil leaks or missing parts.
2. Check the hydraulic oil level sight gauge on the hydraulic tank with the platform fully lowered. Add ISO #46 hydraulic oil if necessary.
3. Check that fluid level in the battery is correct (see Section 3.3, Battery Maintenance).
4. Check the engine oil level and fuel level.
5. Check that all guardrails are in place, the slide out deck extension is secured with the pin and all fasteners are properly tightened.
6. Check tire pressure; 50 psi (3.4 bar)
7. Carefully inspect the entire work platform for damage such as cracked welds or structural members, loose or missing parts, oil leaks, damaged cables or hoses, loose connections and tire damage.
8. Move machine, if necessary, to unobstructed area to allow for full elevation.
9. Place chassis and platform emergency stop switches in the ON position by pulling the buttons out.
10. Verify platform/chassis switch is set to **PLATFORM**.
11. **Dual Fuel Models:** set dual fuel selector to desired position. Set to the center position to purge the system when switching fuels. If the machine is to be operated on propane, open the supply valve on the tank

Note: When using LP gas, use clean, water free liquid petroleum gas, preferably from a bulk storage tank. Follow the instructions located on the power module tray for filling the tank.

WARNING

If you smell propane, close the supply valve on the tank immediately until you have located and corrected the leak.

12. While the engine is cool check the engine coolant level.

CAUTION

DO NOT check coolant when engine or radiator is hot, hot coolant can cause severe burns.

System Function Inspection

WARNING

STAND CLEAR of the work platform while performing the following checks.

Before operating the work platform survey the work area for surface hazards such as holes, drop-offs, bumps and debris.

*Check in **ALL** directions, including above the work platform, for obstructions and electrical conductors.*

Protect control console cable from possible damage while performing checks.

1. Unhook controller from front guardrail. Firmly grasp controller hanger in such a manner that the interlock lever can be depressed, while performing the following checks from the ground.
2. Turn controller key switch clockwise to **ON**. Turn fully clockwise to start engine, releasing the key once the engine starts.

Note: If the engine is cold, on gasoline / propane models, hold the choke button in while starting the engine. On diesel models, depress the glow plug button and hold for 6 seconds to engage the glow plugs.

3. Position drive/lift switch to **DRIVE** position.

4. With the speed range switch first in **HIGH TORQUE** and then in **HIGH SPEED** depress the interlock lever and slowly push the control lever to **FORWARD** then **REVERSE** positions to check for speed and directional control. The farther you push or pull the control lever the faster the machine will travel.
5. Push steering switch **RIGHT** then **LEFT** to check for steering control.
6. Depress the Interlock switch on the control handle and position each Outrigger switch to the **EXTEND** position to deploy all four Outriggers. Check the Drive Enable indicator, it should be off.
7. Fully retract all Outriggers and check the Drive Enable indicator, it should be on.
8. Rehook controller on front guardrail.
9. Turn the platform/chassis switch to **CHASSIS**.
10. Push the throttle button in. Push chassis raise button to elevate platform while pushing the tilt sensor off of level. The platform should only partially elevate and the tilt alarm should sound. If the platform continues to elevate and/or there is no alarm **STOP** and remove the machine from service until it is repaired.
11. Release the tilt sensor and fully elevate platform.
12. Visually inspect the elevating assembly, lift cylinder, cables and hoses for damage or erratic operation. Check for missing or loose parts.
13. Lower the platform partially by pushing in on the chassis lower switch, and check operation of the audible lowering alarm.
14. Open the chassis emergency lowering valve to check for proper operation by pulling and holding the knob out. Once the platform is fully lowered, close the valve by releasing the knob.
15. Turn the platform/chassis switch to **PLATFORM**.
16. Mount the platform making sure the gate is latched.
17. Position drive/lift switch to **LIFT**.
18. Depress the interlock lever and slowly push the control lever to **UP** to raise the platform, fully actuate the control lever to check proportional lift speed. Slowly pull control lever to **DOWN** position to lower platform. Check that lowering alarm sounds.

19. Depress the interlock lever switch on the control lever and position any Outrigger switch to the **EXTEND** position, Outriggers should be disabled. If an Outrigger extends during this test **STOP**. Lower the platform and remove the machine from service until it is repaired.
20. Turn controller key switch to **OFF**, push the emergency stop button and dismount the platform.
21. Close and secure module covers.

2.9 OPERATION

NOTE: Before operating work platform, ensure that the pre-operation and safety inspection has been completed, any deficiencies have been corrected and the operator has been thoroughly trained on this machine.

Travel With Platform Lowered

1. Verify chassis emergency stop switch is in the ON position (turn counterclockwise), the drive enable indicator is on, and that the platform/chassis switch is on **PLATFORM**.

Note: If the drive enable indicator is off, verify that the platform is fully lowered and (if so equipped) the outriggers are fully retracted.

2. After mounting platform, close and latch gate. Check that guardrails are in position and properly assembled with fasteners properly torqued.
3. Check that route is clear of persons, obstructions, holes and drop-offs and is capable of supporting the wheel loads.
4. Check clearances above, below and to the sides of the platform.
5. Pull controller emergency stop button out to **ON** position.
6. Turn controller key switch fully clockwise to start engine, releasing the key once the engine starts.

Note: If the engine is cold, on dual fuel models, depress and hold the choke button in while starting the engine. On diesel models, depress and hold the glow plug button for 6 seconds to engage the glow plugs.

7. Set the drive/lift speed range switch to **HIGH TORQUE**.
8. Grasp the control lever so the interlock lever is depressed (releasing the interlock lever cuts power to controller). Slowly push or pull the control lever to **FORWARD** or **REVERSE** to travel in

the desired direction. The farther you push or pull the control lever from center the faster the machine will travel.

9. While moving, push the drive/lift speed range switch to **HIGH SPEED** for travel on level surfaces or to **HIGH TORQUE** for climbing grades or traveling in confined areas.

Steering

1. Push the steering switch **RIGHT** or **LEFT** to turn the wheels. Observe the tires while maneuvering to insure proper direction.

NOTE: Steering is not self-centering. Wheels must be returned to the straight ahead position by operating the steering switch.

Leveling the Platform (Outrigger equipped machines only)

WARNING

Never operate work platform with the parking brakes released. Serious injury or damage could result.

1. Look around the machine, make sure that there is nothing obstructing the outriggers, and that the surface beneath them is suitable to support the weight of the machine.
2. Depress the interlock lever on the control handle and operate the outrigger switches to extend each outrigger until it is making firm contact with the ground.
3. While observing the bubble level on the front guardrail, (Figure 2-3), extend the outrigger opposite the position of the bubble until the platform is level. For example: if the bubble is to the front and left in the orbit, extend the rear right outrigger. Continue to adjust until the bubble is centered in the small circle indicating that the platform is level.
4. Outriggers must be in firm contact with the supporting surface, observe each outrigger to verify.

To Retract the outriggers

1. Fully lower the platform.
2. Position each outrigger switch to **RETRACT**. Observe the outriggers to ensure that they are fully retracted. The drive enable indicator light will not come on until all four outriggers are fully retracted.

Raising and Lowering the Platform

1. Position the drive/lift switch to **LIFT**.
2. While holding the control lever so the interlock lever is depressed, push the control lever slowly to **UP** to raise the platform. Pushing the control lever farther increases the lift speed.
3. When the work task is completed, position the drive/lift switch to **LIFT** and lower the platform by pulling back on the control lever until the platform is fully lowered.

Travel with Work Platform Elevated

Travel with platform elevated **ONLY** on firm and level surfaces.

Note: The work platform will travel at reduced speed when in the elevated position, and only if the front axle is parallel with the rear axle.

1. Check that the route is clear of persons, obstructions, holes and drop-offs, is level and capable of supporting the wheel loads.
2. Check clearances above, below and to the sides of platform.
3. Position the drive/lift switch to the **DRIVE** position.
4. Push the control lever to **FORWARD** or **REVERSE** for the desired direction of travel.

Note: If the machine quits driving and the tilt alarm sounds, immediately lower the platform and move the machine to a level location before re-elevating the platform.

Emergency Lowering

The emergency lowering control is located at the rear of the machine at the base of the scissor assembly (Figure 3-1).

1. Open the emergency lowering valve by pulling on the knob and holding it.
2. Once the platform is fully lowered, release the knob to close the valve.

Switching Fuels (Dual Fuel Only)

1. With engine running turn the fuel selector switch (Figure 2-3) to the center position.
2. After the engine has quit running select the appropriate fuel supply.
3. Restart the engine.

After Use Each Day

1. Ensure that the platform is fully lowered.
2. Park the machine on level ground, preferably under cover, secure against vandals, children or unauthorized operation.
3. Turn the key switch to **OFF** and remove the key to prevent unauthorized operation.

2.10 PARKING BRAKE RELEASE (FIGURE 2-3)

Perform the following only when the machine will not operate under its own power and it is necessary to move the machine or when winching onto a trailer to transport.

1. Close the needle valve by turning the knob clockwise.
2. Pump the brake release pump until the parking brakes release and the wheels can be turned.
3. The machine will now roll when pushed or pulled.
4. Be sure to open the needle valve and verify that the parking brakes have engaged before the machine is operated.

WARNING

Never operate work platform with the parking brakes released. Serious injury or damage could result.

2.11 FOLD DOWN GUARDRAILS (FIGURE 2-4)

This procedure is only for passing through doorways. Guardrails must be returned to proper position before using the machine.

Fold Down Procedure

Note:When performing the following procedures retain all fasteners.

1. Place controller on platform
2. Starting at the front of the platform, remove nuts, bolts and washers from the top of the front guardrail. Fold the front guardrail down onto the platform.
3. Close and latch the gate.
4. Remove nuts, bolts and washers from the top of the rear guardrail. Fold the rear guardrail down onto the platform being careful to keep latched at all times.
5. Remove nuts, bolts and washers from the top of the side guardrails. Lift up and fold one side guardrail in so it rests on the deck. Repeat with other side guardrails.

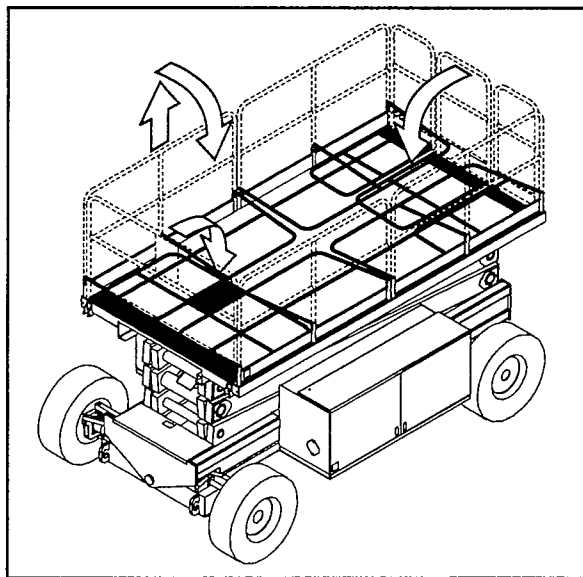

Figure 2-4: Fold Down Guardrails

Erection Procedure

1. Raise side guardrails making sure each is pushed down to secure the guardrail in the vertical position.
2. Install bolts, washers and nuts between the side guardrails, tighten securely.
3. Raise rear guardrail assembly, aligning holes and install bolts, washers and nuts. Tighten securely.
4. Raise front guardrail, aligning holes and install bolts, washer and nuts. Tighten securely.
5. Hang controller from front guardrail.
6. Before operating work platform, check that all fasteners are in place and properly torqued.

⚠ WARNING ⚠

Before operating machine, guardrails must be securely fastened in their proper position.

Section 3

MAINTENANCE

3.1 INTRODUCTION

WARNING

Before performing preventative maintenance, familiarize yourself with the operation of the machine.

Always block the Elevating Assembly, see Figure 3-6, before attempting to perform any maintenance under the scissor assembly.

This section contains instructions for the maintenance of the LX50 Work Platform. Procedures for the operation inspection, adjustment, scheduled maintenance, and repair/removal are included.

Referring to Section 2 will aid in understanding the operation and function of the various components and systems of the work platform, and help in diagnosing and repair of the machine.

Refer to "Preventative Maintenance Check list" on page 3-4 for recommended maintenance intervals.

Note: Unless otherwise specified, torque all fittings according to (see Table 3-3, "Torque Specifications for Fasteners," on page 3-33), and (see Table 3-4, "Torque Specifications for Hydraulic Components," on page 3-33).

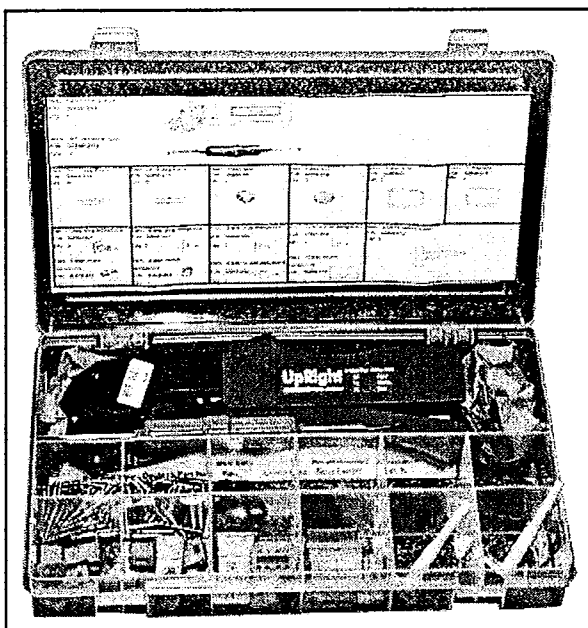

Figure 3-1: Deutsch Connector Kit, Small

3.2 DATE CODE IDENTIFICATION ON HOSES

GATES uses a five digit code: Year, Month, Day.

i.e.: 6 11 29 - means 1996, month 11 (November), day 29.

PARKER uses a ten digit code: Plant, Year, Month, Day.

i.e.: XXXX 6 11 29 - means Plant XXXX, 1996, month 11 (November), day 29.

DAYCO stamps month, day and year on each hose.

3.3 SPECIAL TOOLS

The following is a list of special tools which may be required to perform certain maintenance procedures on the work platform.

- 0-1000 PSI Hydraulic Pressure Gauge with Adapter Fittings
- 0-3000 PSI Hydraulic Pressure Gauge with Adapter Fittings
- Small Deutsch Connector Field Kit (UpRight P/N 030899-000)
- Large Deutsch Connector Field Kit (UpRight P/N 030898-000)
- Inclinator (P/N 010119-000)
- Flow Meter (P/N 067040-000)

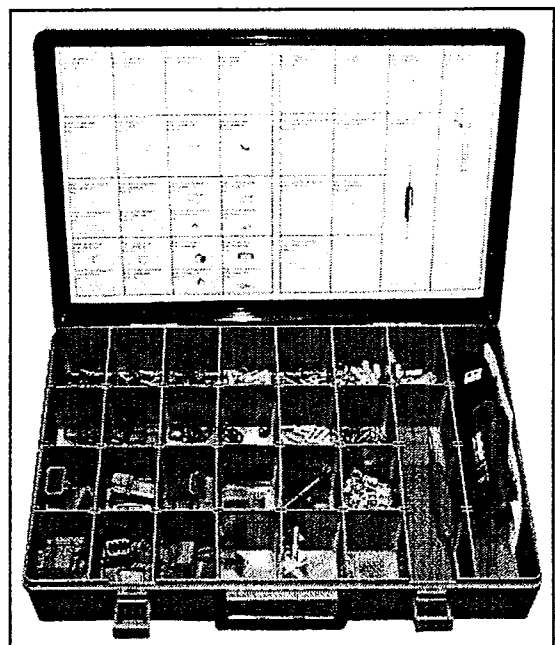

Figure 3-2: Deutsch Connector Kit, Large

Deutsch Connectors

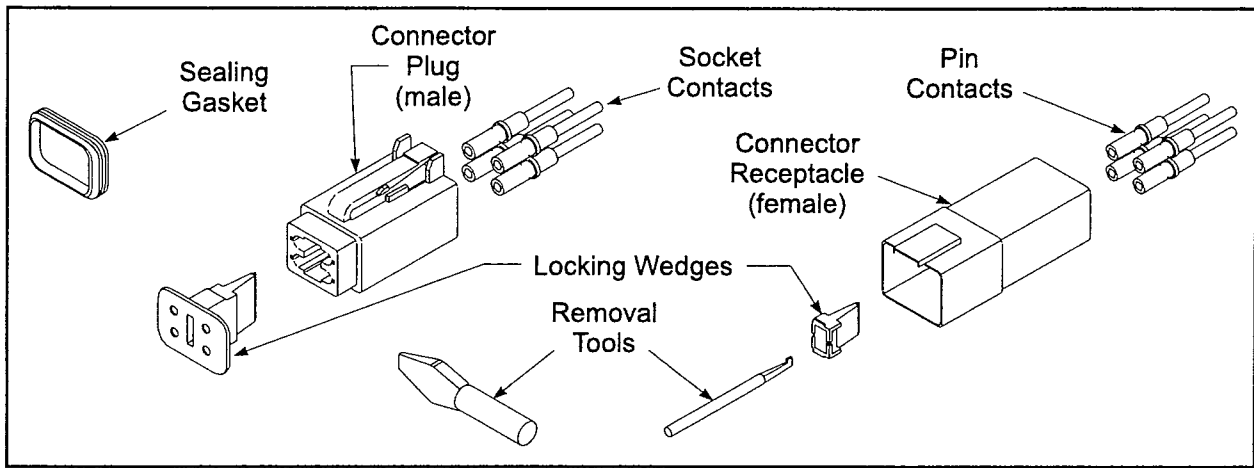

Figure 3-3: Plugs and Receptacles, Deutsch Connectors

Deutsch connectors are designed so that connector parts, contacts or electrical cables may be replaced without replacing the entire connector.

Male Connector (Plug)

1. Disconnect the male connector (plug) from the female connector (receptacle).
2. Using the flat end of the Removal Tool (or flat blade screwdriver), pry the Locking Wedge from the Male Connector. Care should be taken that the Silicon Gasket is not damaged during this procedure.
3. Check all parts for damage. Replace all parts which are damaged or worn.
4. Replace or recrimp the wires and contacts. Refer to "Crimping" procedure.

FEMALE CONNECTOR (Receptacle)

1. Disconnect the male connector (plug) from the female connector (receptacle).
2. Using the notched end of the Removal Tool (or a wire hook), pull the Locking Wedge from the Female Connector.
3. Check all parts for damage. Replace all parts which are damaged or worn.
4. Replace or recrimp the wires and contacts. Refer to "Crimping" procedure.

Releasing Locking Fingers

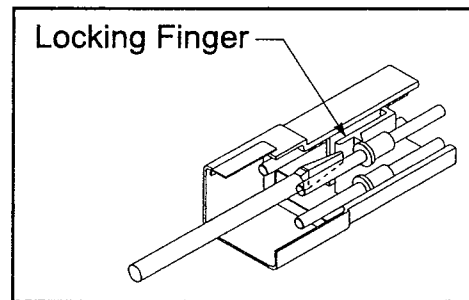

Figure 3-4: Locking Finger, Deutsch Connector

1. The Locking Fingers can be released following the removal of the Locking Wedge of either the male or female connector.
2. Use the removal tool (or flat bladed screwdriver) to push the Locking Fingers aside. This will release the grip on the contact.
3. Pull the wire and contact out of the connector.

Crimping

Note: Complete crimping instructions are included in each Field Kit.

1. Strip 1/4" (6 mm) from the wire.
2. Insert the contact into the crimping tool.
3. Insert the stripped wire into the contact. Copper strands should be visible in the bleed hole of the contact and no copper strands should be loose (outside) of the contact barrel.
4. Completely close the handles of the crimping tool. Release the handles of the crimping tool and remove the crimped contact.
5. Inspect the crimped contact to ensure that all strands are secure in the crimp barrel.

Removing Contact From Heavy Duty Plug

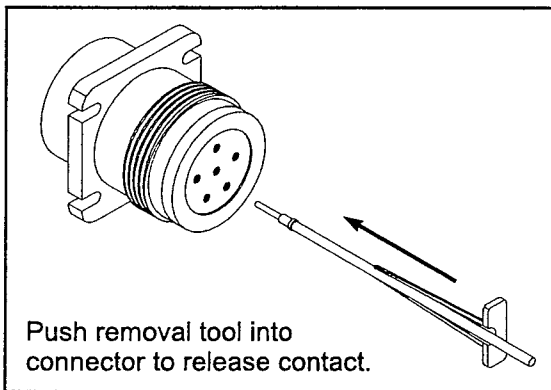

Figure 3-5: Heavy Duty Deutsch Connector

1. Slip the removal tool along the wire to be replaced.
2. Push the removal tool into the connector until the contact is released.
3. Pull the wire and contact out of the plug.

3.4 PREVENTATIVE MAINTENANCE

The Complete inspection consists of periodic visual and operational checks, together with all necessary minor adjustments to assure proper performance. Daily inspection will prevent abnormal wear and prolong the life of all systems. The inspection and maintenance schedule is to be performed at regular intervals. Inspection and maintenance shall be performed by personnel who are trained and familiar with mechanical and electrical procedures.

⚠ WARNING ⚠

Before performing preventative maintenance, familiarize yourself with the operation of the machine.

Always block the elevating assembly whenever it is necessary to enter the scissor assembly to perform maintenance while the platform is elevated.

The preventative maintenance table has been designed to be used primarily for machine service and maintenance repair. Please photocopy the following page and use this table as a checklist when inspecting the machine for service.

Preventative Maintenance Table Key

Interval

Daily=each shift or every day
 50h/30d=every 50 hours or 30 days
 250h/6m=every 250 hours or 6 months
 1000h/2y=every 1000 hours or 2 years

Y=Yes/Acceptable N=No/Not Acceptable
 R=Repaired/Acceptable

Preventative Maintenance Report

Date: _____
 Owner: _____
 Model No: _____
 Serial No: _____
 Serviced By: _____
 Service Interval: _____

Table 3-1: Preventative Maintenance Check list

COMPONENT	INSPECTION OR SERVICES	INTERVAL	Y	N	R
Battery	Check electrolyte level	6m			
	Check specific gravity	6m			
	Clean exterior	6m			
	Check battery cable condition	Daily			
	Clean terminals	6m			
Engine Oil and Filter	Check level and condition	Daily			
	Check for leaks	Daily			
	Change oil filter	100h			
Engine Fuel System	Check fuel level	Daily			
	Check for leaks	Daily			
	Replace fuel filter	6m			
Engine Coolant	Check air cleaner	Daily			
	Check coolant level (with engine cold)	Daily			
Hydraulic Oil	Replace coolant	3m			
	Check oil level	Daily			
	Change filter	6m			
Hydraulic System	Drain and replace oil	2y			
	Check for leaks	Daily			
	Check hose connections	30d			
	Check hoses for exterior wear	30d			
Emergency Hydraulic System	Operate the emergency lowering valve and check for serviceability	Daily			
Controller	Check switch operation	Daily			
Control Cable	Check the exterior of the cable for pinching, binding or wear	Daily			
Platform Deck and Rails	Check fasteners for proper torque	Daily			
	Check welds for cracks	Daily			
	Check condition of deck	Daily			
Tires	Check for damage	Daily			
	Check lug nuts (torque to 90 ft. lbs.)	30d			
Hydraulic Pump	Wipe clean	30d			
	Check for leaks at mating surfaces	30d			
	Check for hose fitting leaks	Daily			
	Check mounting bolts for proper torque	30d			
Drive Motors	Check for operation and leaks	Daily			
Torque Hubs	Check for leaks	Daily			
	Check oil level	250h/6m			
	Change Oil after break-in	50h/30d			
	Change Oil	1000h/2y			

COMPONENT	INSPECTION OR SERVICES	INTERVAL	Y	N	R
Steering System	Check hardware & fittings for proper torque	6m			
	Grease pivot pins	30d			
	Oil king pins	30d			
	Check steering cylinder for leaks	30d			
Elevating Assembly	Inspect for structural cracks	Daily			
	Check pivot points for wear	30d			
	Check mounting pin pivot bolts for proper torque	30d			
	Check elevating arms for bending	6m			
Chassis	Check hoses for pinch or rubbing points	Daily			
	Check component mounting for proper torque	6m			
	Check welds for cracks	Daily			
Lift Cylinders	Check the cylinder rod for wear	30d			
	Check mounting pin pivot bolts for proper torque	30d			
	Check seals for leaks	30d			
	Inspect pivot points for wear	30d			
	Check fittings for proper torque	30d			
Axle Cylinder	Check the cylinder rod for wear	30d			
	Check mounting pin pivot bolts for proper torque	30d			
	Check seals for leaks	30d			
	Inspect pivot points for wear	30d			
	Check fittings for proper torque	30d			
Entire Unit	Check for and repair collision damage	Daily			
	Check fasteners for proper torque	3m			
	Check for corrosion-remove and repaint	6m			
	Lubricate	30d			
Labels	Check for peeling, missing, or unreadable labels & replace	Daily			

3.5 BLOCKING ELEVATING ASSEMBLY (FIGURE 3-6)

⚠ WARNING ⚠

Never perform service on the work platform in the elevating assembly area while platform is elevated without first blocking the elevating assembly.

DO NOT stand in elevating assembly area while deploying or storing brace.

Installation

1. Park the work platform on firm level ground.
2. Verify Platform Emergency Stop Switch is **ON**.
3. Turn Chassis Key Switch to **CHASSIS**.
4. Start the engine using chassis controls.
5. Push the throttle button in, the button will stay in and the engine speed will increase. Using the raise button, elevate platform until the scissors brace can be rotated to the vertical position.
6. From the left side of the machine, disengage the locking pin securing the brace. Rotate the scissor brace counterclockwise until it is vertical and between the two scissor center pivots.
7. Push lower button and gradually lower platform until brace is supporting the platform.
8. Disengage throttle by pushing throttle button in again, the button will retract and the engine will come to idle speed.

Removal

1. Using chassis controls, gradually raise platform until the scissors brace clears the two scissor center pivots.
2. Rotate scissors brace clockwise until the locking pin engages.
3. Push lower button to completely lower platform.
4. Make sure the throttle button is disengaged and platform/chassis switch is on **PLATFORM**.

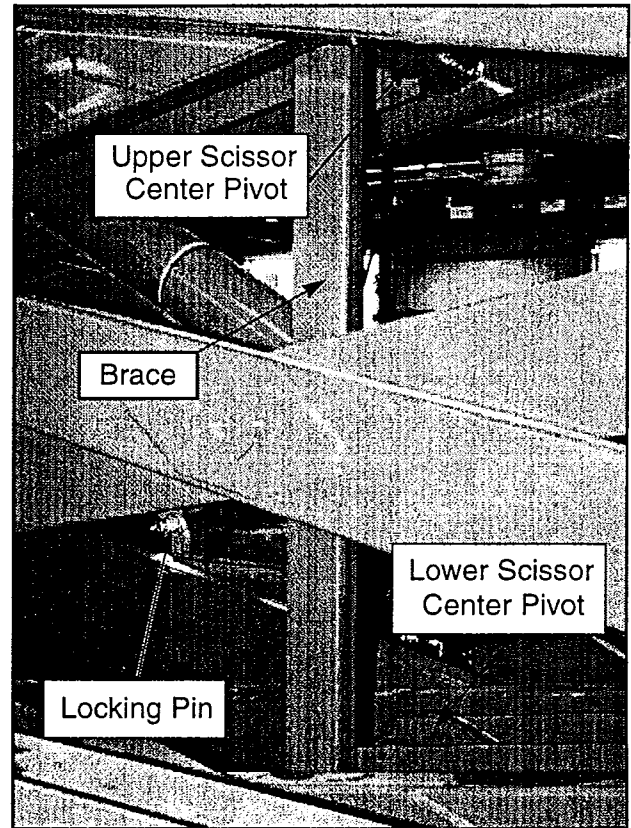

Figure 3-6: Blocking Elevating Assembly

3.6 BATTERY MAINTENANCE

⚠ WARNING ⚠

Hazard of explosive gas mixture. Keep sparks, flame, and smoking material away from battery.

Always wear safety glasses when working with batteries.

Battery fluid is highly corrosive. Thoroughly rinse away any spilled fluid with clean water.

Battery Inspection and Cleaning

Check battery fluid level daily, especially if work platform is being used in a warm, dry climate. If required, add distilled water **ONLY**. Use of tap water with high mineral content will shorten battery life.

The battery and cables should be inspected regularly for signs of cracks in the case, electrolyte leakage and corrosion of the terminals. Inspect cables for worn spots or breaks in the insulation and for broken cable terminals.

Clean the battery when it shows signs of corrosion at the terminals or when electrolyte has overflowed during charging. Use a baking soda solution to clean the battery, taking care not to get the solution inside the cells. Rinse thoroughly with clean water. Clean battery and cable contact surfaces to a bright metal finish whenever a cable is removed.

3.7 LUBRICATION

Refer to Table 3-1 for the lubrication intervals and Figure 3-7 for location of items that require lubrication service. Refer to the appropriate sections for lubrication information on the Steering Linkage, Torque hubs, Hydraulic Oil and Filter, and Engine Oil and Filter.

Grease Fittings

Wipe each grease fitting before and after greasing. Using multipurpose grease in a grease gun, pump the grease into the fitting until grease just begins to appear at the edges of the pivot, wipe off any excess grease.

Steering Linkage

Apply one or two drops of penetrating oil to each pivot and King Pin bearing.

Torque Hubs

Note: Change oil in torque hubs after the first 50 hours of operation. Change every 1000 hours thereafter.

1. Remove Torque Hub from rear drive assembly (refer to Section 3.12).
2. Remove drain plug from underside of Torque Hub.
3. Drain oil from unit.
4. Replace drain plug.
5. Remove fill plug from top side of Torque Hub.
6. Fill unit with 90 wt. gear oil.
7. Replace fill plug.

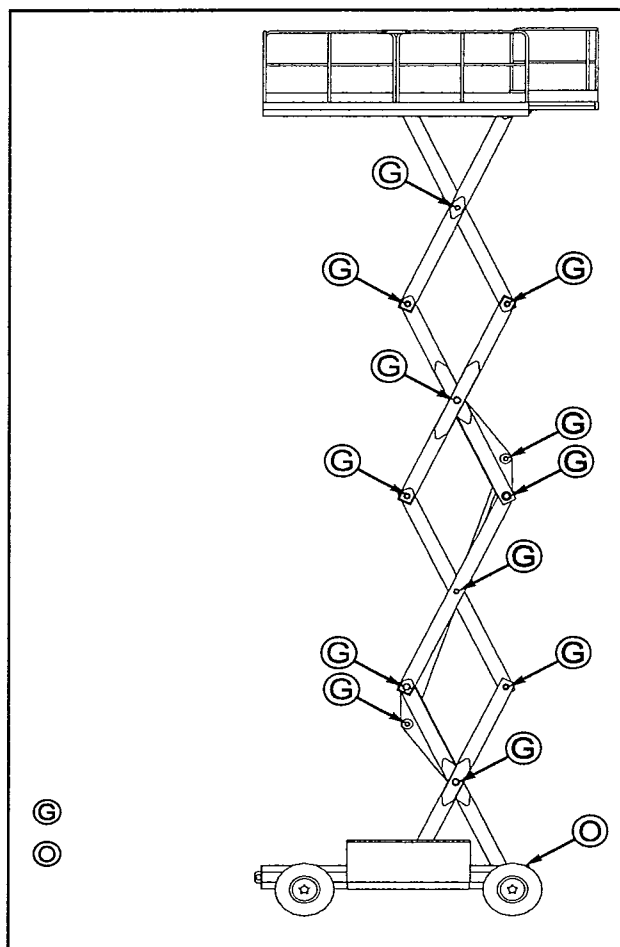

Figure 3-7: Lubrication Chart

Hydraulic Oil Tank and Filter (Figure 3-8)

Fluid Level

With the platform *fully lowered*, the oil should be visible in the Sight Gauge. If the oil is NOT visible, fill the tank until the oil can be seen. DO NOT fill above the Sight Gauge or when the Platform is elevated.

Oil and Filter Replacement

1. Operate the work platform for 10-15 minutes to bring the hydraulic oil up to normal operating temperature.

CAUTION

The hydraulic oil may be hot enough to cause burns. Wear safety gloves and safety glasses when handling hot oil.

2. Provide a suitable container to catch the drained oil. The hydraulic tank has a capacity of 12.0 U.S. gallons (45.5 l).
3. Remove the drain plug and allow all oil to drain into the container, be sure to dispose of oil properly.
4. Reinstall the drain plug.
5. Remove the three screws from the filter body cover and open the filter body.
6. Lift the filter element from the filter body.
7. Fill the hydraulic oil tank to the level of the sight gauge with ISO #46 hydraulic oil.
8. Insert the replacement filter element into the filter body and press into position.
9. Replace the filter body cover and screws.

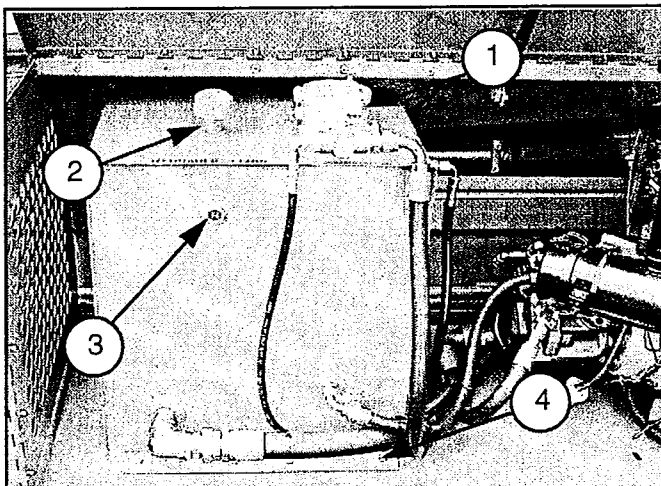

1. Filter body
2. Breather
3. Sight Gauge
4. Drain plug (under tank)

Figure 3-8: Hydraulic Oil Tank & Filter

Engine Oil & Filter (Figure 3-9)

1. Provide a suitable container to catch the drained oil. Engine oil capacity is 4 quarts (3.25 l).
2. Place the container under the oil pan and remove the drain plug.
3. When the drain plug is removed, unscrew the filler cap to speed up draining the oil.
4. After all of the oil has been drained, replace the drain plug.
5. Remove the filter using an oil filter wrench.
6. Replace with new filter, refer to section 6 for part number. Tighten filter by hand.

Note: Lubricate filter seal with clean engine oil prior to assembly.

7. Fill engine with motor oil per Table 3-2.
8. Replace filler cap.

Engine	Capacity	Temp	Oil
Gas/Propane	4 US qts [3.25 l]	above 10° f below 10° f	10w-30 5w-30
Diesel	5.4 US qts. [5.1 l]	All	10w-30

Table 3-2: Engine Oil

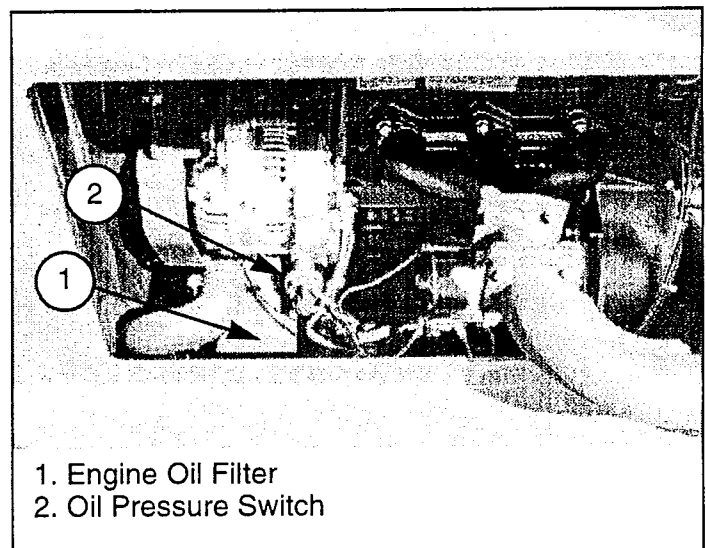

1. Engine Oil Filter
2. Oil Pressure Switch

Figure 3-9: Engine Oil Filter

3.8 SETTING HYDRAULIC PRESSURES

Note: Follow Pump Set - Up procedure whenever Pump has been replaced, or when testing performance to isolate possible failure. Refer to Figure 3-11 for flow meter setup.

Pump Setup (Figure 3-10)

1. Remove Pump output line and cap it.
2. Install flow meter input line to Pump output.
3. Remove Tank return line and cap.
4. Install flow meter output line to Tank.
5. Remove sense line from Pump.
6. Install flow meter sense line to Pump.
7. Remove caps on Standby and Max Pressure adjustment screws.
8. Press and hold Throttle Button to rev up engine.
9. Close simulated load flow control valve by turning fully clockwise.
10. Turn Standby pressure adjustment screw fully clockwise.
11. Adjust Max Pressure to 3000 P.S.I. (207 bar) (clockwise to increase, counterclockwise to decrease).
12. Turn Standby pressure adjustment screw counterclockwise until gauge reads 200 P.S.I. (14 bar).
13. Replace caps on Standby and Max Pressure adjustment screws.
14. Open simulated load flow control valve by turning fully counterclockwise.
15. Open simulated load pressure relief valve by turning fully counterclockwise.
16. Loosen large locknut on Horsepower Limiter Valve and turn adjustment screw counterclockwise two full turns.
17. Increase simulated load pressure relief valve by turning clockwise until gauge reads 1500 P.S.I. (105 bar).
18. Turn Horsepower Limiter adjustment screw clockwise until flow meter reads 12 G.P.M.
19. Tighten large locknut on Horsepower Limiter Valve.
20. Loosen small locknut on Horsepower Limiter Valve and turn adjustment screw counterclockwise two full turns.
21. Increase simulated load pressure relief valve by turning clockwise until gauge reads 2500 P.S.I. (172 bar).

22. Turn Horsepower Limiter Valve adjustment screw clockwise until flow meter reads 7 G.P.M.
23. Tighten small locknut on Horsepower Limiter Valve
24. Replace hoses.

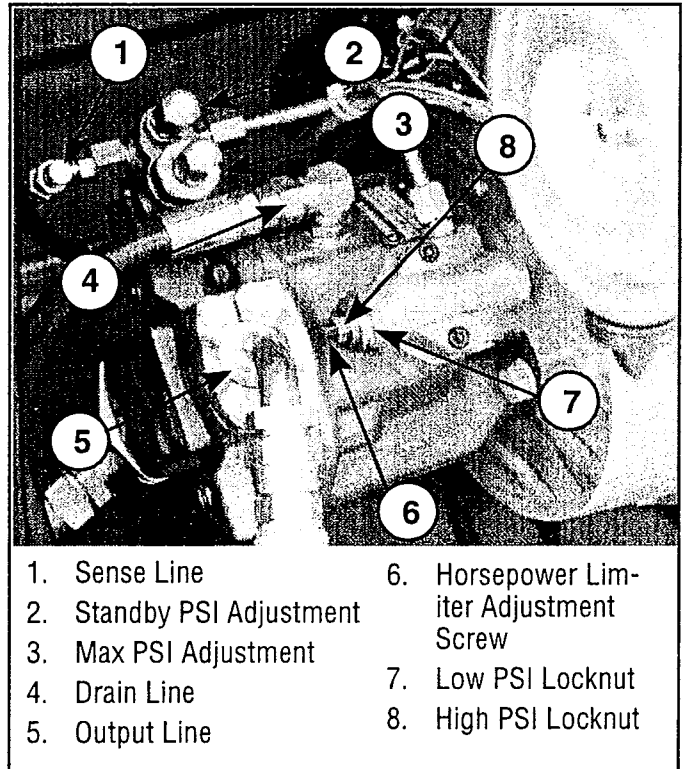

Figure 3-10: Hydraulic Pump

Lift Relief Valve

1. Operate the hydraulic system 10-15 minutes to warm the oil.
2. Remove the cap or loosen the locknut on the Lift Relief Valve.
3. Turn the Lift Relief Valve adjustment screw counterclockwise two full turns.
4. Place rated load on the platform (1000 lbs. [454 kg.]).
5. Depress the Throttle Button, and the Raise Button to lift the platform.
6. Slowly turn the Lift Relief Valve adjustment screw clockwise until the platform begins to rise.
7. Replace the cap, or tighten the locknut on the Lift Relief Valve, and remove the load from the platform

Counterbalance Valves

1. Operate the hydraulic system 10-15 minutes to warm the oil.
2. Elevate the Front (4WD only), and Rear Wheels to allow them to spin freely, and place on jackstands suitable to support the weight of the machine.
3. Remove the Green/White wire from wire terminal in the Control Panel Assembly.
4. Install a 0-1000 P.S.I. pressure gauge at the Forward Drive Pressure Test Port.
5. Loosen the locknut on the **Reverse** Counterbalance Valve, push the control handle **FORWARD**, and adjust the valve until the gauge reads 800 P.S.I. (55 bar) (CW to decrease P.S.I., CCW to increase P.S.I.) Tighten the locknut.
6. Install a 0-1000 P.S.I. pressure gauge at the Reverse Drive Pressure Test Port.
7. Loosen the locknut on the **Forward** Counterbalance Valve, push the control handle **REVERSE**, and adjust the valve until the gauge reads 800 P.S.I. (55 bar), tighten the locknut.
8. Recheck the pressures and adjust as necessary.
9. Remove the gauge and replace the cap. Replace the Green/White wire to terminal. Lower the machine off of the jackstands.

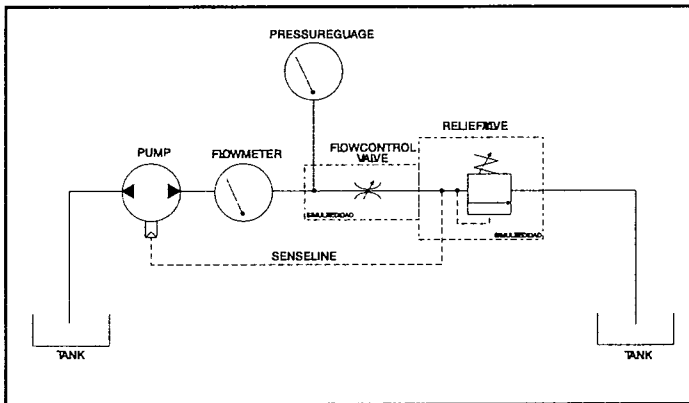

Figure 3-11: Flow Meter Setup

Steering Relief Valves

1. Operate the hydraulic system 10-15 minutes to warm the oil.
2. Install a 0-3000 P.S.I. gauge at the Main Pressure Test Port.

3. Loosen the locknut or remove the cap on the Left Steer Relief Valve.
4. Turn the adjustment screw two full turns counterclockwise.
5. Press the Steering Switch to the left and hold until the system bypasses.
6. Turn the Steering Relief Valve adjustment screw clockwise until the gauge reads 1500 P.S.I. (103 bar)
7. Tighten locknut or replace cap on Left Steering Relief Valve.
8. Repeat process for Right Steering Relief Valve

Bidirectional Relief Valves

Note: Check or reset Drive Motor Relief Valves only if you suspect that one of the Rear wheels is not turning due to premature bypass. This condition is rare and Bidirectional Relief Valves should not be reset as part of normal maintenance.

1. Operate the hydraulic system 10-15 minutes to warm the oil.
2. Remove the cap and install a 0-3000 P.S.I. pressure gauge at the Main Pressure Test Port.
3. Remove the Bidirectional Relief Valve from under the rear drive motor and exchange with the Lift Relief Valve.
4. Remove the cap from the Bidirectional Relief Valve and turn the adjustment screw two full turns counterclockwise.
5. Depress the Throttle Button and the Raise Button to lift the platform to full height and hold until system bypasses.
6. Turn the adjustment screw clockwise until the pressure reaches 3000 P.S.I. (207 bar).
7. Replace the cap and return the Bidirectional Relief Valve and the Lift Valve to their original positions.
8. Repeat if necessary for the other Bidirectional Relief Valve.
9. Remove the gauge and replace the Test Port Cap.

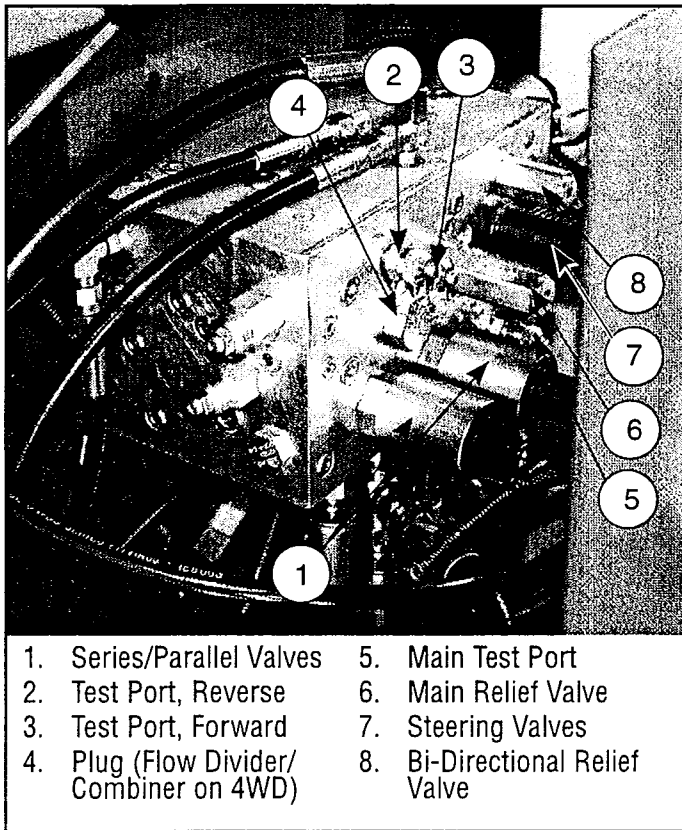

Figure 3-12: Valve Manifold

3.9 SWITCH ADJUSTMENTS

Proportional Control Adjustment (Figure 3-13)

When required by the following procedure, lay out a twenty foot course, on level ground, free from pot-holes or other obstructions. Mark a starting line and finish line visible from the platform of the machine.

Potentiometers are sealed to protect sensitive adjustments from vibrations, or from tampering. Remove sealant prior to adjustment, and replace after.

Use a small screwdriver or special adjustment tool to set adjustment pots. Pots can be easily damaged.

Pots have 15 turns of adjustment, more than one turn will often be required to complete the adjustment. If pots have been previously set, reset by turning no more than turn at a time. If they have not been previously set, preset to about mid range and start from there.

Turn pot clockwise (CW) to increase settings.

Turn pot counterclockwise (CCW) to decrease settings.

Adjust pots only in sequence as outlined in this procedure.

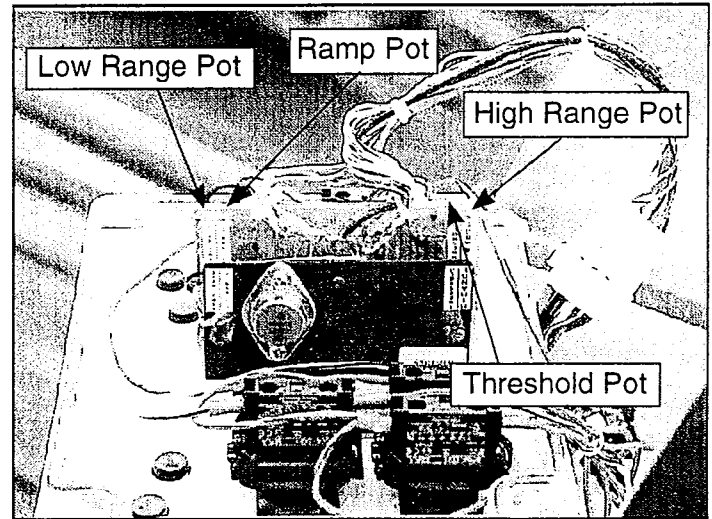

Figure 3-13: Proportional Controller

Procedure

1. Lower machine fully to insure that controller is in high speed range.
2. Turn Ramp Trimpot fully counterclockwise until a click is heard with each revolution.
3. Push Control Handle slightly forward, just enough to illuminate the red L.E.D. on the P.C.B.

Note: Do not steer the wheels during speed test, ensure that the front wheels are straight prior to this operation. Allow the machine to rise to full speed, and mark the time from the second that the front wheels cross the starting line, until the second that the front wheels cross the finish line.

4. Adjust the Threshold Trimpot so that the machine just begins to move.
5. Push the Control Handle fully forward and drive the machine over the 20 foot course.
6. Adjust the Hi Trimpot to the proper high speed.
7. Elevate the platform enough to put the machine into low speed range.
8. Push the Control Handle fully forward and drive the machine over the 20 foot course.
9. Adjust the Lo Trimpot to the proper low speed.
10. Lower the machine fully and turn the Ramp Trimpot 8 to 10 turns clockwise. Adjust for smooth acceleration.
11. Recheck speeds to insure proper adjustment. Reset as necessary.

Platform Down Limit Switches

The Platform Down Switches (Figure 3-14) close the circuit to the Cutout Relay, bypassing the Tilt Sensor when the platform is lowered; and to the Platform Down Relay, which provides power to the Drive Relay, Proportional Controller high speed circuit, and Series/Parallel Relay.

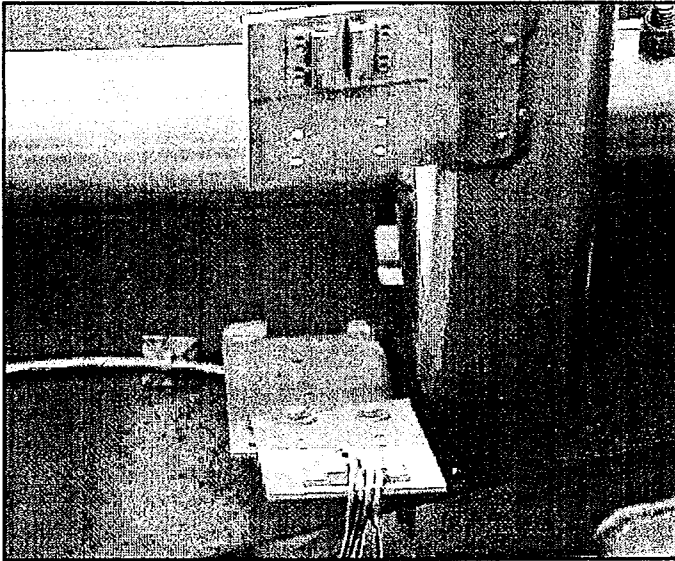

Figure 3-14: Platform Down Limit Switch

1. Lower the Platform completely.
2. With the Platform / Chassis switch on Chassis, push the Tilt Sensor base to test the alarm circuit.

⚠ WARNING ⚠

DO NOT attempt to adjust Limit Switches without first blocking the elevating assembly (Figure 3-6).

3. If the alarm sounds, elevate the Platform and adjust the position of the switch mounting bracket by loosening the capscrews and nuts holding the bracket in place and moving the bracket until the switches align with the magnets. Lower the Platform and retest. When switches are aligned, alarm will not sound while platform is lowered.
4. With platform elevated, repeat step 2. When switches are properly adjusted, alarm will sound.

Axle Center Switch (Figure 3-15)

1. Place the work platform on a level surface with the front and rear axles parallel (on the same plane). Verify this using an inclinometer.
2. Loosen the setscrew on the lever of the limit switch. It should immediately spring to center. Tighten the setscrew.
3. Test the switch function by moving the machine to a location where the front axle will articulate off of center and raising the platform until the magnetic switches open (about 10 feet [3 meters]). The work platform should not drive. Retest with the axle off center in the other direction.

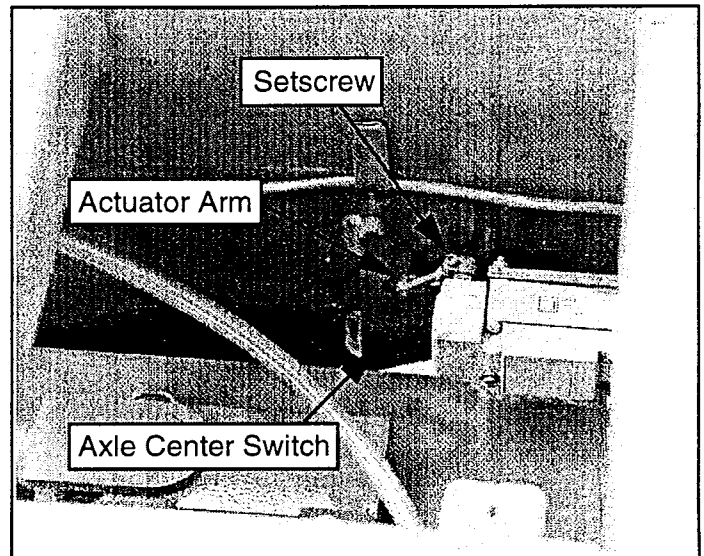

Figure 3-15: Axle Center Switch

Tilt Sensor (Figure 3-16)

The Tilt Sensor has three wires; red-power (12v in), black-ground, white-output (12v out). To verify the sensor is working properly there is one LED under the sensor, red indicates the sensor is out of level and the white wire is 'hot' (12v out).

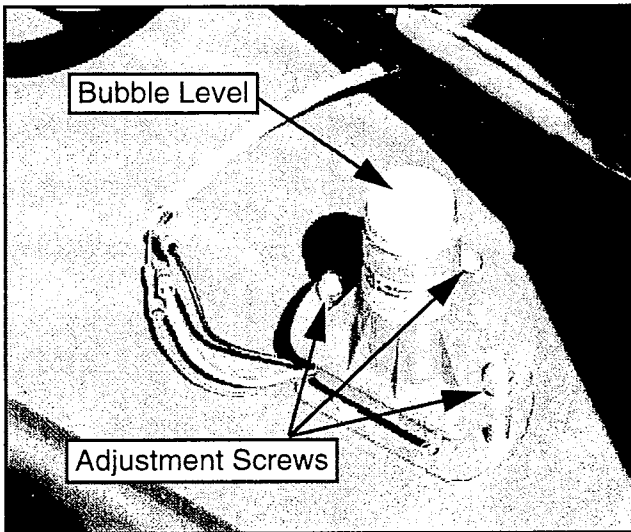

Figure 3-16: Tilt Sensor

1. Check tires for proper pressure.
2. Place machine on firm level surface $\pm 1/4^\circ$.
3. Use Inclinometer to ensure that the front and rear of the Chassis are level within $\pm 1/4^\circ$.
4. Adjust the three leveling locknuts until the bubble is centered in the circle on the attached bubble level.
5. Elevate the platform until the magnetic switches open (about 10 feet [3m]) and push the tilt sensor base to test the alarm circuit. Alarm should sound.

3.10 HYDRAULIC MANIFOLD (FIGURE 3-17)

Though it is not necessary to remove the manifold to perform all maintenance procedures, a determination should be made prior to beginning as to whether or not the manifold should be removed before maintenance procedures begin.

Removal

1. Disconnect the battery ground cable.
2. Unplug valve block wiring harness.
3. Tag, disconnect and plug hydraulic hoses.
4. Remove the bolts that hold the manifold mounting bracket to the module floor.
5. Remove manifold block.

Disassembly

NOTE: Mark all components as they are removed so as not to confuse their location during assembly. Refer to Figure 3-17 often to aid in disassembly and assembly.

1. Remove coils from solenoid valves.
2. Remove spool valve cover and spool valve.
3. Remove solenoid valves, lift relief valve, counter-balance valves and divider/combiner valve.
4. Remove fittings, plugs, springs, balls and orifices.

Cleaning and Inspection

1. Wash the manifold in cleaning solvent to remove built up contaminants and then blow out all passages with clean compressed air.
2. Inspect the manifold for cracks, thread damage and scoring where O-rings seal against internal and external surfaces.
3. Wash and dry each component and check for thread damage, torn or cracked O-rings and proper operation.
4. Replace parts and O-rings found unserviceable.

Assembly

NOTE: Lubricate all O-rings before installation to prevent damage to O-rings. Seat all balls in manifold block by lightly tapping on the ball with a brass drift punch.

1. Install fittings, plugs, springs, balls and orifices. Use one drop of Loctite #242 on each screw-in orifice.
2. Install solenoid valves, lift relief valve, counter balance valves, divider combiner valve, and spool valve.
3. Install coils on solenoid valves.

Installation

1. Attach manifold assembly to mounting plate with bolts.
2. Connect Solenoid leads to terminal strip (as previously tagged).
3. Connect hydraulic hoses. Be certain to tighten hoses to manifold.
4. Operate each hydraulic function and check for proper operation and leaks.
5. Adjust Lift Relief, Steering Relief, and Counter-balance Valve pressures according to instructions in Section 3.8

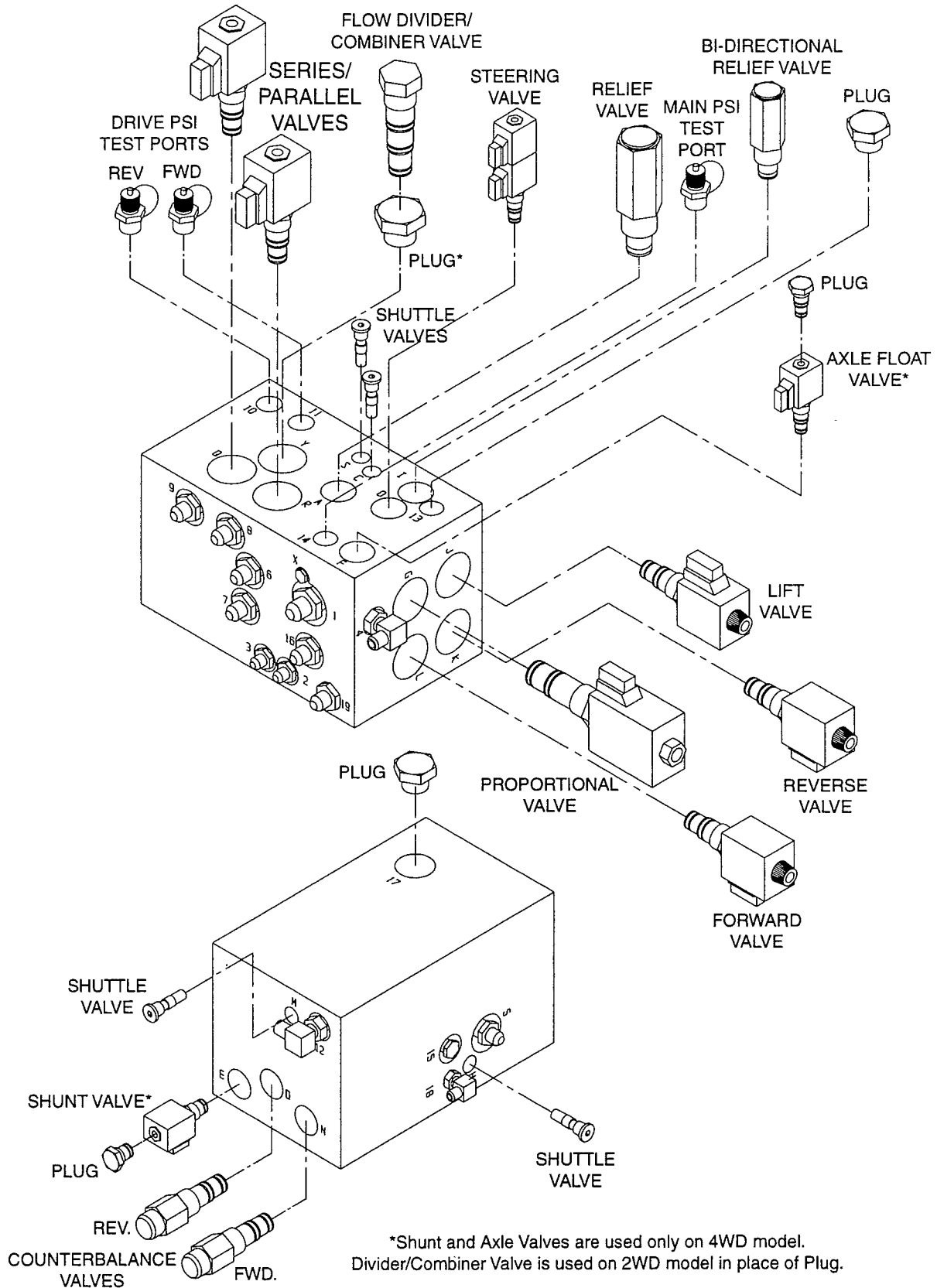

Figure 3-17: Hydraulic Manifold, Exploded View (4WD Shown)

3.11 HYDRAULIC PUMP (FIGURE 3-18)

NOTE: If the hydraulic tank has not been drained, suitable means for plugging the hoses should be provided to prevent excessive fluid loss.

Removal

1. Mark, disconnect and plug the hose assemblies.
2. Loosen the capscrews and remove the pump assembly from the engine.

Installation

1. Torque each capscrew a little at a time until both capscrews are torqued to 20 ft. lbs. (27 N-m).
2. Unplug and reconnect the hydraulic hoses.
3. Fill the pump completely with clean hydraulic oil by pouring it into the drain line cavity.
4. Check the oil level in the hydraulic tank before operating the work platform.
5. Set standby and maximum pressures, and horsepower limiter nodes as outlined under Pump Setup in Section 3.8, Setting Hydraulic Pressures.

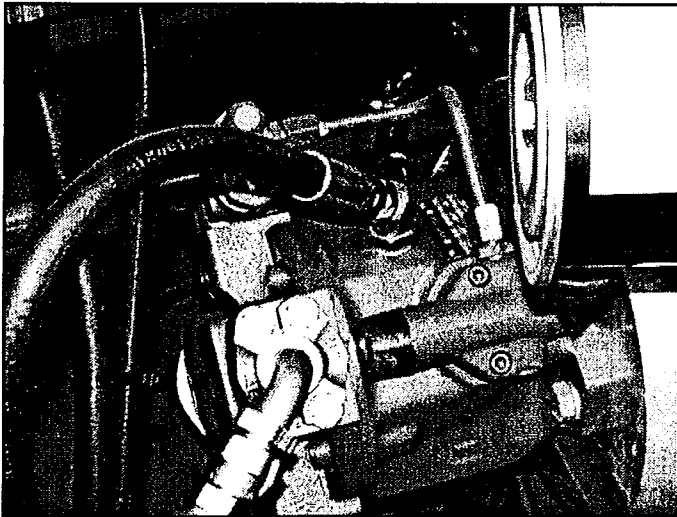

Figure 3-18: Hydraulic Pump

3.12 HYDRAULIC BRAKES, DRIVE MOTORS, AND HUBS

Rear Axle Removal (Figure 3-19)

1. Park the work platform on firm level ground and block the wheels to prevent the work platform from rolling.
2. Loosen the wheel lug bolts on the motor to be removed.

3. Raise the rear of the work platform using a 2-ton jack.
4. Position 2 1-ton jack stands under the rear axle to prevent the work platform from falling if the jack fails.
5. Remove the wheel lug bolts and wheel.
6. Tag and disconnect the hose assemblies from the drive motor and brake.

⚠ CAUTION ⚠

Clean all fittings before disconnecting the hose assemblies.

Plug all port holes and hose assemblies IMMEDIATELY to prevent contamination from dust and debris.

Note: When disassembling, retain gaskets between components, they may be reused if undamaged.

7. Remove the four capscrews holding the motor to the brake. Remove the motor.
8. Remove the two socket head through bolts connecting the brake and the torque hub. Remove the brake.
9. Remove the eight capscrews connecting the torque hub to the rear axle. Remove the torque hub.

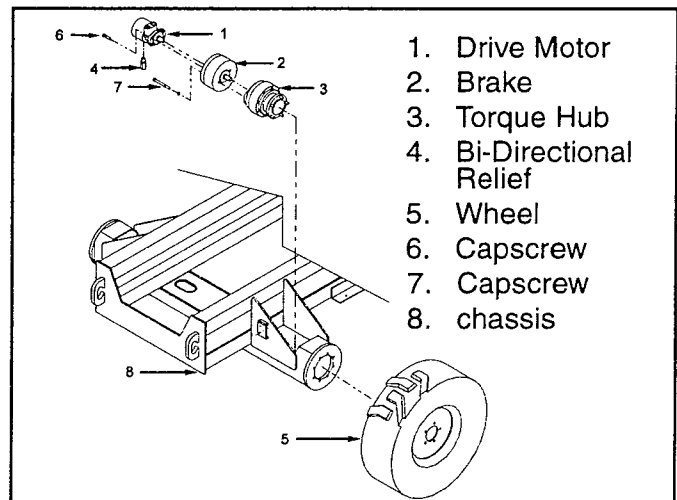

Figure 3-19: Rear Axle assembly

Installation

1. Install the torque hub to the rear axle. Align the holes and install the eight capscrews, tighten.
2. Coat the output shaft of the brake with high pressure molybdenum grease and install brake into torque hub. Align holes and install the two socket head through bolts, tighten.
3. Coat the output shaft of the drive motor with high pressure molybdenum grease and install into brake. Align holes and install the four capscrews, tighten.
4. Reinstall the hose assemblies to the drive motor and brake.
5. Reinstall the wheel and wheel nuts onto the torque hub. Torque the wheel nuts to 150 ft. lbs. [203 Nm].
6. Remove the jack stands used to block the wheels. Lower the jack and remove.
7. Operate the drive system to check for leaks. If the brake was serviced, bleed out the air using the bleed valve located on the brake housing.

Seal Replacement (Figure 3-20)

1. With shaft protrusion downward, remove the capscrews (22) from the brake assembly.
2. Remove the power plate (20), from the housing (1).
3. Remove the gasket (2), discard.
4. Remove the piston (13) from the power plate (20) by introducing low pressure air (15 psi) into the hydraulic

inlet. Make sure the piston is pointed away from any one.

5. Remove O-rings (15 & 17) and backup rings (14 & 16) from the inner and outer diameter grooves of the piston, discard.
6. Clean the piston (13) from the power plate (20) assemblies with solvent. Inspect the sealing surfaces of the piston (13) and power plate (20). Inspect the seal grooves in the piston. Replace these parts if they are damaged or scratched deeply. Lubricate piston (13), power plate (20), and seals (14-17) with clean hydraulic oil prior to assembly.
7. Install the backup rings (14 & 16) and O-rings (15 & 17) into the seal grooves in the piston.
8. Install the piston into the power plate using a shop press. Be careful not to damage the seals during assembly. Center the cutouts in the piston with the torque pin holes in the power plate. Press the piston to a depth no less than flush, but not exceeding 0.120 in below the surface of the power plate at the cutouts in the piston. This depth is critical, the brake will not hold if it is exceeded.
9. Install gasket (2).
10. Install power plate/piston assembly (13 & 20) to housing (1) using capscrews (22). Tighten sequentially, one at a time, to press the two assemblies together. Torque capscrews 50 to 60 ft. lbs.

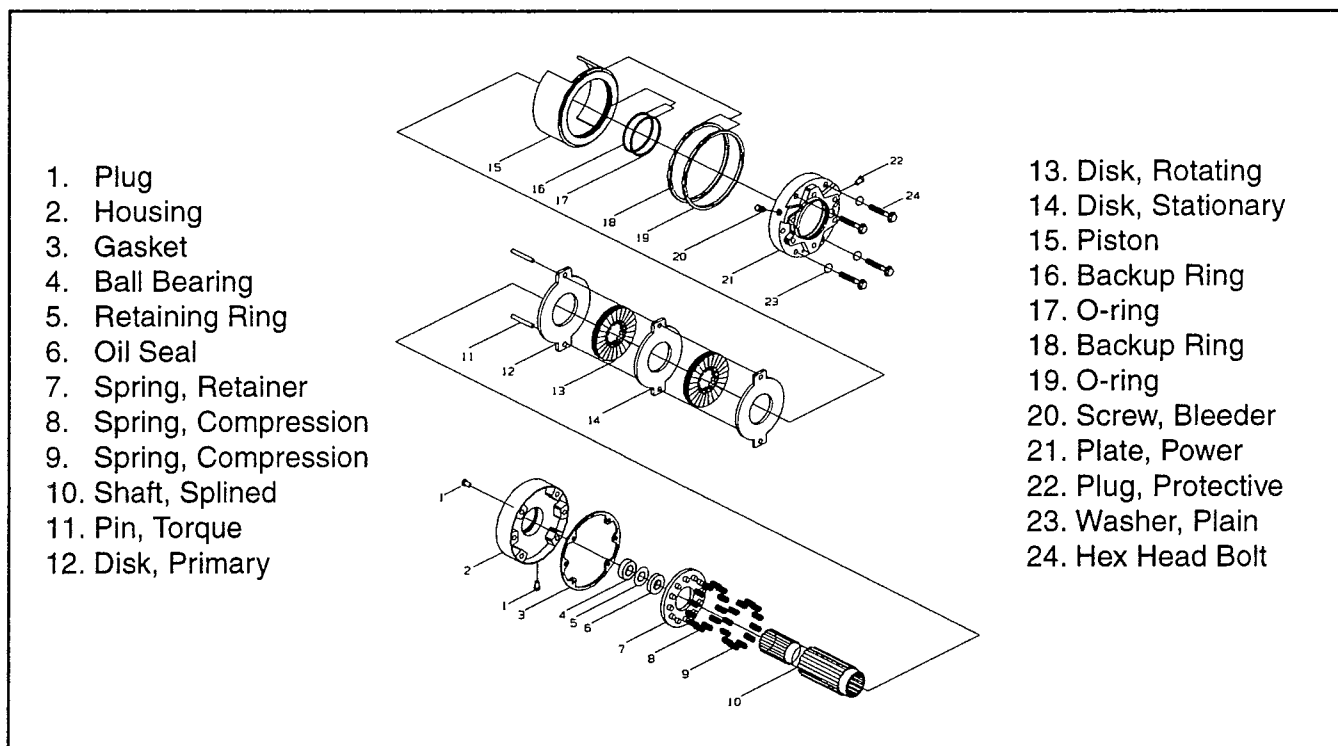
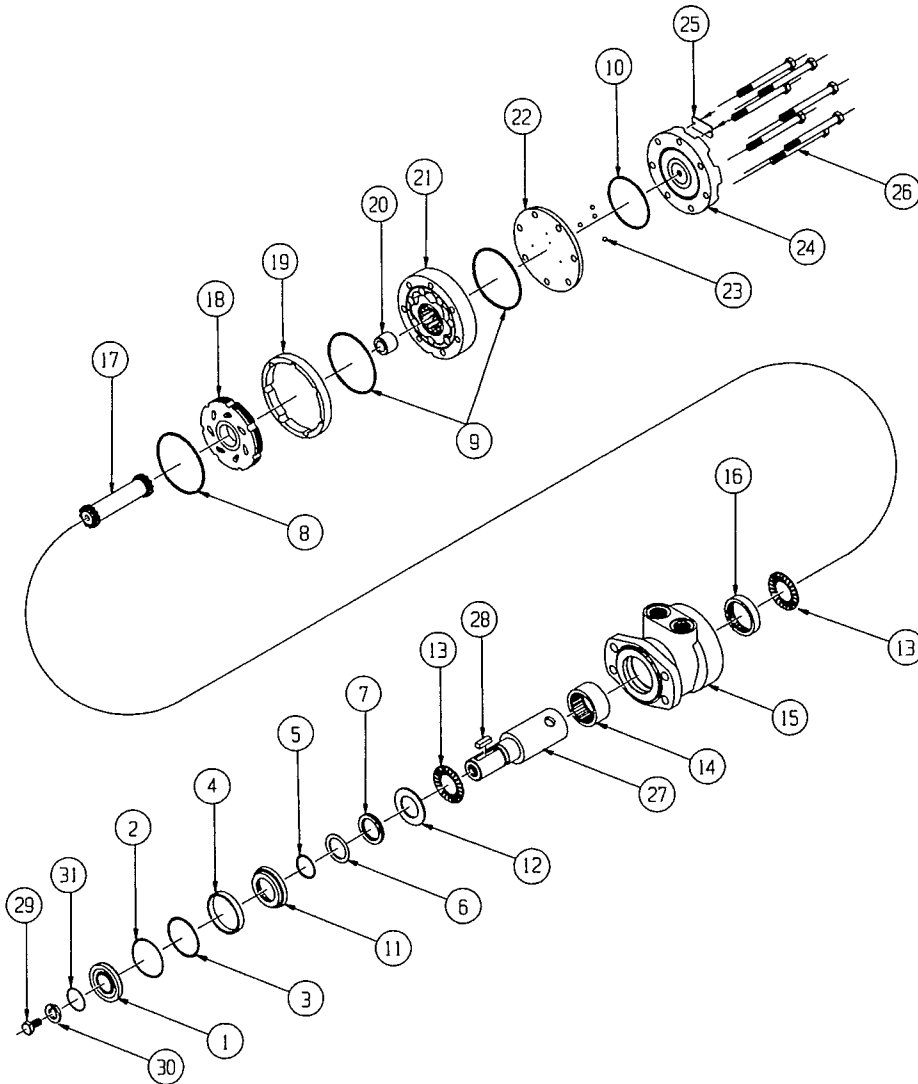

Figure 3-20: Brake Assembly

Seal Replacement, Rear Motor (Figure 3-21)

1. Remove all shaft related components from shaft (27), i.e. keys, wire rings, nuts. To aid in reassembly of the motor, make a "v" shaped set of lines from the end cover (24) to the housing using either paint or a marker. With shaft facing down, secure motor in vise by clamping onto housing (15).
2. Loosen and remove seven bolts (26) holding motor assembly together. Remove end cover (24) and body seal (10). Discard seal. Remove balance plate (22) taking care not to drop the four steel balls (23) located in the four holes in the balance plate (22). Remove rotor assembly (21), manifold boot (19), manifold (18), drive link spacer (20) (*Note: Some motors do not use spacer*), drive link (17) and thrust bearing (13). Remove body seals (9) from rotor assembly (21) and housing seal (8) from housing (15) and discard seals. (*note: compare old housing seal (8) to the two housing seals included in kit to determine which one to use.*)
3. Gently tap shaft (27) upward from housing (15) and remove through rear of housing and lay aside. Remove housing (15) from vise and turn over. Pry dust seal (1) from housing. Push the seal carrier (11), thrust washer (12) and thrust bearing (13) down until they make contact with the roller bearing (14) located in the housing bore.
4. Remove wire ring (2), steel backup shim (3), and high pressure seal (4) from inner bore groove with a small screwdriver (*note: compare old high pressure seal (8) to the two high pressure seals included in kit to determine which one to use.*). Lift out seal carrier (11), thrust washer (12) and thrust bearing (13) from the housing bore. Using a small screwdriver, carefully pry shaft seal (7), teflon backup seal (6) and metal backup shim (5) from seal carrier (11) and discard. Lay seal carrier (11), thrust washer (12) and thrust bearing (13) aside. (*note: if a new thrust washer seal (12) and seal carrier (11) is included in kit, old items may be discarded*).
5. At this point, all parts should be cleaned in an oil-based solvent and dried using compressed air (for safety, observe all OSHA safety guidelines). All new seals should be lightly coated in clean oil prior to installation.
6. Place shaft (27) on a clean, flat surface with output end facing up. Place thrust bearing (13), then thrust washer (12) on shaft. Lightly coat seal area of shaft with clean oil and place plastic installation sleeve with shaft seal (7) down onto shaft, covering all splines, keyways and wire ring grooves. Slide shaft seal (7) down onto shaft (27) making sure that lip on seal faces down (see Figure 3-21 for correct seal orientation) until it contacts thrust washer (12). Remove plastic installation sleeve. Carefully install the teflon backup seal (6) onto the shaft (27) with the flat side up and the seal lip facing the shaft seal (7). Place the metal backup shim (5) onto the shaft and against the teflon backup seal (6). Place the seal carrier (11) onto the shaft (large end down) and carefully press the seal carrier (11) down onto the seal assembly using an arbor press and sleeve to compress the seals into the carrier.
7. With pilot side facing up, place housing (15) on spacers to raise housing approximately .250 above work surface (*note: spacers should allow shaft to contact work surface*). Place shaft/seal carrier assembly into housing (15). Install high pressure seal (4) into groove in housing. Install metal backup shim (3) against high pressure seal (4) in groove in housing bore by squeezing the shim (3) between thumb and forefinger to bow shim. While maintaining bow in shim, start the shim into the groove and use a small screwdriver to push the shim into groove. Install wire ring (2) into the groove making sure that the ends are butted.
8. While holding shaft into housing, place housing/shaft assembly in vise with shaft end down. Making sure that end of drive link (17) with crowned splines goes into shaft end, install drive link (17) into shaft and tap lightly to seat the seal carrier assembly against the wire ring (2). Place thrust bearing (13) over drive link (17). If seal carrier (27) is properly seated against wire ring (2), thrust bearing (13) will be flush with rear surface of housing.
9. Install housing seal (8) into groove in housing (15). Place manifold (18) onto housing (15) with side with only seven holes facing housing (15). Install manifold boot (19) over manifold (18) and align bolt holes. Place body seals (9) in grooves in both sides of rotor (21). Place rotor (21) onto manifold (18) with side of rotor with chamfer in splines facing manifold (18).
10. Install balance plate (22) onto rotor (21) making sure side with holes for steel balls (23) faces up. Install four steel balls (23) in holes in balance plate (22). Install end cover seal (10) into groove in end cover (24) and place end cover onto balance plate (22). Install seven assembly bolts (26) and pre-torque to 10 ft.lbs. Using the bolt torque sequence shown in Figure 3-21, final torque all bolts to 50 ft.lbs.
11. Remove motor from vise and place on work surface with shaft (27) facing up. Making sure that lip on seal (1) faces up, place dust seal (1) over shaft (27). Using a sleeve and a hammer, carefully drive dust seal (1) into place.



1. Dust Seal
2. Split Wire Ring
3. Metal Backup Shim
4. High Pressure Seal
5. Metal Backup Shim
6. Teflon Backup Seal
7. Shaft Seal
8. Housing Seal
9. Body Seals (2)
10. End Cover Seal
11. Seal Carrier
12. Thrust Washer
13. Thrust Bearing (2)
14. Front Housing Bearing
15. Housing
16. Rear Housing Bearing
17. Drive Link
18. Manifold
19. Manifold Boot
20. Drive Link Spacer
21. Rotor Assembly
22. Balance Plate
23. Steel Balls (4)
24. End Cover
25. I.D. Tag Assembly
26. Assembly Bolts (7)
27. Shaft
28. Shaft Key
29. Shaft Bolt
30. Lock Washer
31. Wire Ring

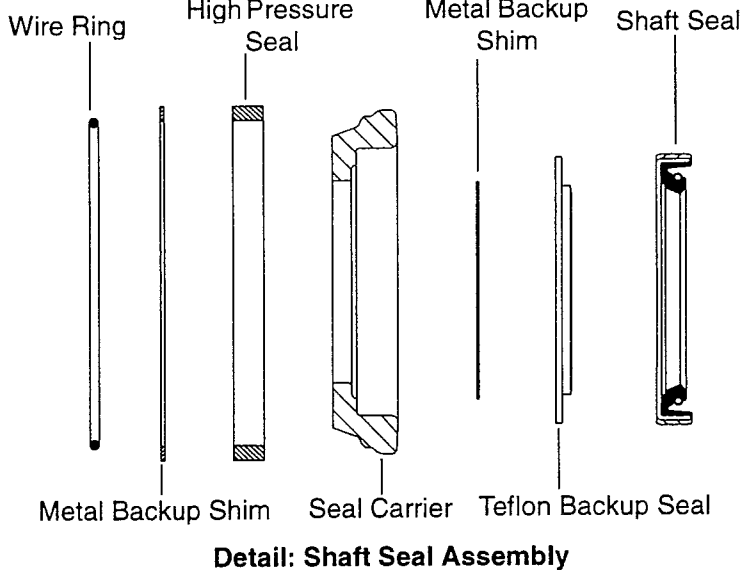

Detail: Shaft Seal Assembly

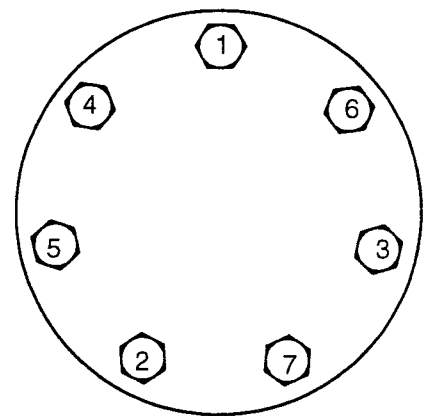

Detail: Bolt Tightening Sequence

Figure 3-21: Rear Drive Motor Assembly

Front Axle 4WD (Figure 3-22)

Removal

1. Park the work platform on firm level ground and block the wheels to prevent the work platform from rolling.
2. Loosen the wheel lug bolts on the motor to be removed.
3. Raise the front of the work platform using a 2-ton jack.
4. Position two 1-ton jack stands under the front axle to prevent the work platform from falling if the jack fails.
5. Remove the wheel nuts and wheel.



CAUTION



ONLY use a wheel puller to remove the hub. Using any other method of removal may damage the drive motor housing and void the warranty.

Clean all fittings before disconnecting the hose assemblies.

Plug all port holes and hose assemblies IMMEDIATELY to prevent contamination from dust and debris.

6. Tag and disconnect the hose assemblies.
7. Remove the screw and nut from the end of the steering link. Swing the connecting link clear of the steering link.
8. Remove the "E" ring from the steering link pin.
9. Lift the connecting link off of the steering link pin.
10. Swing the trunnion assembly around to gain access to the inside.
11. Remove the four nuts from inside the trunnion and remove the drive motor/hub assembly.

Installation

1. Position the drive motor/hub assembly into the steering trunnion and secure with the four nuts, tighten.
2. Install the connecting link onto the steering link pin and secure with the "E" ring.
3. Swing the connecting link toward the steering link, and align the holes. Install the screw and nut, tighten.
4. Install the hose assemblies.
5. Install the wheel and wheel nuts onto the hub. Torque the wheel nuts to 150 ft. lbs. [203 Nm].
6. Remove the jack stands used to block the wheels. Lower the jack and remove.
7. Operate the drive system to check for leaks.

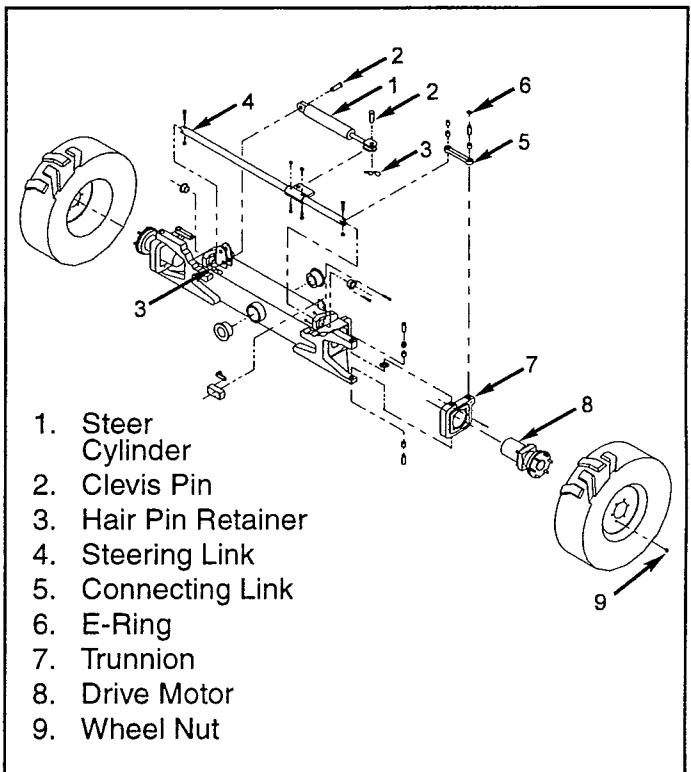
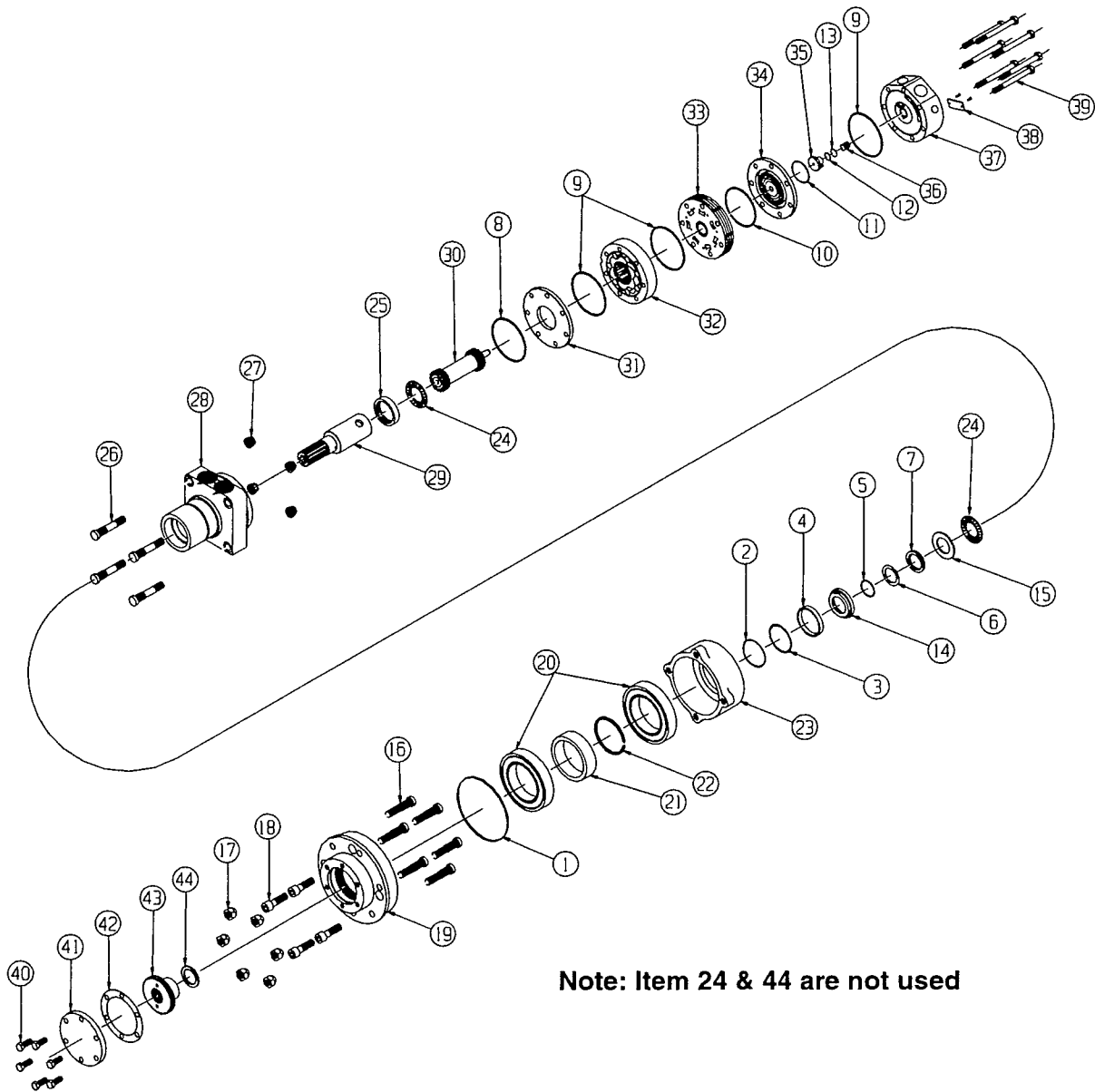

Figure 3-22: Front Axle Assembly, 4WD



Note: Item 24 & 44 are not used

- | | | |
|-----------------------|------------------------|-------------------------------|
| 1. Flange Seal | 13. Teflon Backup Seal | 25. Rear Housing Bearings |
| 2. Wire Ring | 14. Seal Carrier | 26. Planetary Mount Studs (4) |
| 3. Metal Backup Shim | 15. Thrust Washer | 27. Mounting Nuts (4) |
| 4. High Pressure Seal | 16. Studs (6) | 28. Housing |
| 5. Metal Backup Shim | 17. Lug nuts (6) | 29. Shaft |
| 6. Teflon Backup Seal | 18. Capscrews (4) | 30. Drive Link |
| 7. Shaft Seal | 19. Wheel Flange | 31. Divider Plate |
| 8. Housing Seal | 20. 125mm Bearings (2) | 32. Rotor Assembly |
| 9. Body Seals (3) | 21. Bearing Spacer | 33. Manifold |
| 10. Manifold Seal | 22. Thrust Washer | 34. Commutator Assembly |
| 11. Commutator Seal | 23. Bearing Hub | 35. End Cover Piston |
| 12. O-Ring Seal | 24. Thrust Bearings | 36. Piston Spring |
| | | 37. End Cover |
| | | 38. I.D. Tag Assembly |
| | | 39. Assembly Bolts (7) |
| | | 40. Drive Cover Screws (6) |
| | | 41. Drive Cover |
| | | 42. Paper Gasket |
| | | 43. Driver |

Figure 3-23: Front Drive Motor Assembly

Seal Replacement, Front Motor (Figure 3-23 & Figure 3-24)

1. Remove six bolts (40) from end cap (41). Lift end cap (41) off of wheel flange (19). Peel or scrape paper gasket (42) off of end cap and/or wheel flange (19). If grease is between end cap (41) and driver (43), remove grease. Screw a 1/4-20 bolt (not included) into one of the two threaded holes in the driver (43) and lift the driver out of the wheel flange (19). If grease is between driver (43) and housing pilot (28), remove grease.
2. To aid in reassembly of the motor, make a "v" shaped set of lines from the end cover (37) to the housing (28) using either paint or a marker. With hub facing down, secure motor in vise by clamping on to housing (28). Loosen and remove seven bolts (39) holding motor assembly together. Remove end cover (37) carefully as piston (35) and spring (36) may fall out. If piston does not come out, carefully pry piston (35) out of end cover (37) and lay aside. Remove o-ring seal (12) and teflon backup seal (13) from end cover and discard seals. Remove spring (36) and lay aside.
3. Lift commutator container and commutator (34) from motor and lay aside. Place commutator on a flat, clean surface with the seal (11) facing up. Place the tip of a small screwdriver on the seal (11) and gently tap until opposite side of seal lifts from groove. Remove seal and discard.
4. Remove manifold (33), rotor set (32) and divider plate (31) from motor. Remove all seals (8, 9, & 10) from components and discard. (caution- do not allow rolls to drop from rotor assembly (32) when removing rotor assembly from motor.) Remove drive link (30) from motor and lay aside.
5. Remove motor from vise and re-clamp in vise with pilot side of housing facing up. Using a brass hammer, carefully tap shaft (29) down until rear shaft bearing (25) is protruding from rear housing surface approximately 5/8". Using a small screwdriver, remove wire ring (2), metal backup shim (3) and high pressure seal (4) from inner bore groove. Remove shaft/seal carrier assembly (29, 14, 5-7) up through housing. Remove seal carrier (14), thrust washer (15) and thrust bearing (24) from shaft and lay aside.
6. Using a small, flat bladed screwdriver, carefully pry shaft seal (7), teflon backup seal (6) and metal backup shim (5) from seal carrier (14) and lay aside. Lay seal carrier (14), thrust washer (15) and thrust bearing (24) aside.
7. At this point, all parts should be cleaned in an oil-based solvent and dried using compressed air (for safety, observe all OSHA safety guidelines). All new seals should be lightly coated in clean oil prior to installation.
8. (note: shaft seals for 1-1/4" and 1-1/2" shafts are included in this kit. To determine which new seal to use for servicing, refer to old shaft seal). Place shaft on a clean surface with output end facing up. Install thrust bearing (24) and then thrust washer (15) onto shaft. After coating shaft seal (7) and teflon backup seal (6) with clean oil, install shaft seal (7) onto shaft with lip facing. Install teflon backup seal (6) with lip facing down followed by metal backup shim (5) (See Figure 3-24 for correct seal position). Install seal carrier (14) onto shaft with large end facing down. Using a sleeve and press, gently press seal carrier (14) down to compress seal assembly (5-7) into seal carrier (14).
9. Place housing (28) in vise with pilot of housing facing up. Place spacer under housing (28) to prevent shaft (29) from dropping to work surface. Spacer should allow shaft to be about 1/2" below rear surface of housing.
10. Place shaft/shaft seal assembly into housing (28) with output end facing up. Install high pressure seal (4) into groove in inner bore of housing (28). Install metal backup shim (3) against high pressure seal (4) by squeezing the shim (3) between thumb and forefinger to bow shim. While maintaining bow in shim, start the shim into the groove and use a small screwdriver to push the shim into groove. Install wire ring (2) into groove making sure that the ends are butted.
11. While holding shaft into housing, secure housing/shaft assembly in vise with shaft end down. Gently tap shaft bearing (25) down into housing until bearing is approximately 1/16" below rear housing surface. Install drive link (30) into shaft and gently tap drive link (30) down to seat seal carrier (14) against wire ring (2). If shaft (29) is seated properly against wire ring (2), rear surface of shaft (29) should be flush with rear surface of housing (28).
12. Install housing seal (8) into groove in housing (28). Place divider plate (31) onto housing (28) aligning bolt holes. Place body seals (9) in grooves in both sides of rotor (32). Place rotor (32) onto divider plate (31) with side of rotor with chamfer in splines facing divider plate (31). Place manifold (33) onto rotor (32) with seal groove side up. Install manifold seal (10).
13. Install the commutator seal (11) into the commutator (34) with the metal side facing up. Use finger pressure to press the seal down flush with the surface of the commutator. Place the commutator container onto the manifold (33) and then place the commutator onto the protruding end of the drive link (30) making sure that the seal side faces up.

14. Install the remaining body seal (9) in the groove in the face of the end cover (37). Install piston spring (36) into end cover (37), then the white teflon backup seal (13) followed by the o-ring seal (12). Lining up the alignment pin with the hole in the end cover, press piston (35) into the end cover (37). While holding the piston (35) in the end cover (37), lower the end cover assembly onto the motor. Check to make sure that the end cover ports are in their original position.
15. Install the seven assembly bolts (39) and pre-torque to 10 ft. Lbs. Using bolt torque sequence shown in Figure 3-24, final torque all bolts to 50 ft. Lbs.
16. Place spacer (44) over shaft (29). Place driver (43) over shaft (29) while rotating wheel flange (19) slightly to allow splines to mate. Place paper gasket (42) onto wheel flange (19). Reapply grease between driver (43) and end cap (41) (only if end cap (41) does not have grease fitting). Place end cap (41) onto wheel flange (19). Install six bolts (40) and torque to 150 ft. Lbs. Using the bolt torque sequence shown in figure 3. If end cap (41) has grease fitting, apply grease.

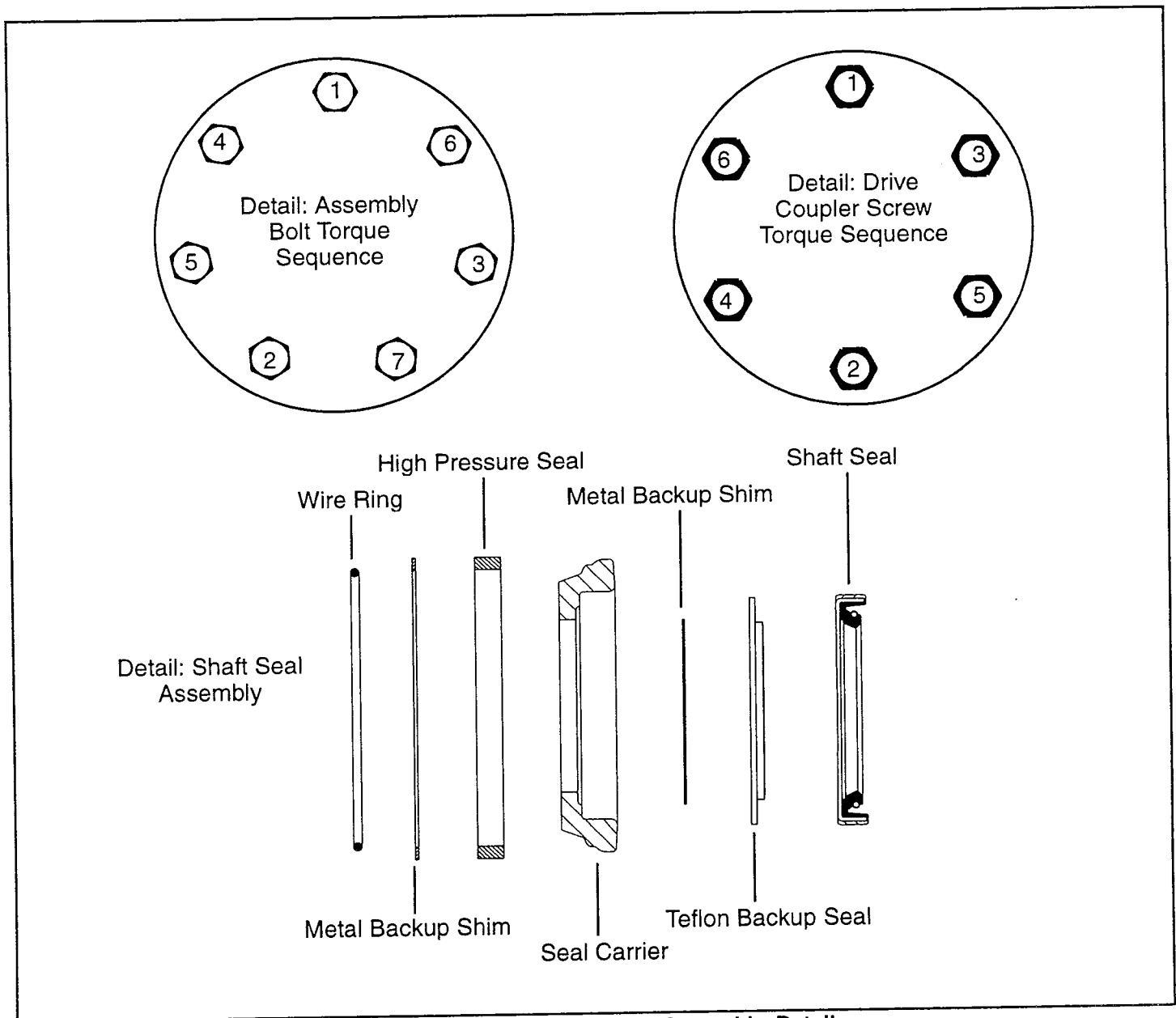

Figure 3-24: Front Drive Motor Assembly, Details

3.13 AXLE CYLINDER (4WD ONLY)

Removal (Figure 3-25)

Note: Be sure platform is fully down and that machine is on level ground.

1. Lift the chassis with a 2 ton jack, and place 1 ton jackstands underneath the left and right frame members just behind the articulating axle assembly. Lower the jack. The weight of the front of the chassis should *now* be supported by the jackstands, and the front wheels should *still* be allowed to touch the ground.
2. Remove the four screws from the front axle cover, remove cover.
3. Remove and cap the hoses.
4. Remove the hex nuts from the cylinder pins at both ends, remove pins.
5. Remove the cylinder from of the chassis.

Seal Replacement (Figure 3-22)

Note: Provide a clean work area for this operation, and observe clean assembly practices. Seals and hydraulic cylinder components are highly sensitive to contamination that may not even be visible to the naked eye.

1. Use a spanner wrench to unscrew the head from the cylinder body tube.
2. Carefully slide the rod, piston, and head out of the body tube and place on a clean surface.
3. Remove cotter pin from cylinder rod.
4. Unscrew the slotted nut from the rod end.
5. Remove the piston from the rod.
6. Slide the rod out of the head.
7. Remove all of the old seals and wear rings, discard.
8. Thoroughly clean all parts with solvent. Rinse the inside of the tube and allow to drain. A high pressure rinse and wipe with a lint free rag is preferable.
9. Inspect the rod, head, piston, and tube for scratches, pits, or polishing. Check seal groves and sealing surfaces. Scratches or pits deep enough to catch the fingernail are unacceptable, replace the affected component. Polishing is a sign of uneven loading, when this occurs, the surface should be checked for roundness. Surfaces not round within .007" should be replaced.
10. Lubricate all components and seals with clean hydraulic oil prior to assembly.

Note: During seal replacement steps, do not use sharp edged tools to avoid cutting the seals. After assembling all seals, allow at least one hour for the seals to elastically restore to their original shape before assembly. Refer to Figure 3-21 for component identification and placement.

11. Separate the three components of the piston seal. Stretch the rubber inner ring over the piston and into the seal groove. Warm the teflon outer ring to 150°F using heated hydraulic fluid or water. Stretch the teflon outer ring into the seal groove. Clean the groove in the teflon ring and install the quad ring. Verify that none of the rings have twisted.
12. Install the glass filled nylon wear rings into the outer grooves in the piston.
13. Twist the U-Cup seal into a 'C' shape and allow it to snap into the groove in the head.
14. Use the above technique to install the wiper into the head.
15. Install the static o-ring and the static backup ring into the grove in the head. Verify that the backup ring is closest to the threads.
16. Install the sealing o-ring between the threads and the flange lip on the head, be careful not to damage the o-ring on the threads.
17. Slide the head assembly onto the rod.
18. Install the static o-ring into the groove on the rod.
19. Install the piston onto the rod.
20. Install the slotted nut and torque to 325 to 520 ft.-lbs. Install the cotter pin. Do not back off on the slotted nut to install the cotter pin. Once the torque has reached 325 ft.-lbs., increase until the next slot aligns with the hole in the rod.
21. Slide the piston, rod, and head into the tube. Be careful not to damage the piston seal on the threads during assembly. If necessary, use shim stock to protect the piston seal when inserting.
22. Use a spanner wrench to tighten the head.

Installation

1. Remove the pilot operated check valves and completely fill both ends of cylinder with hydraulic oil. Replace the pilot operated check valves.
2. Attach both ends of the cylinder to the upper and lower attachments with cylinder pins.
3. Install the hex nuts onto the cylinder pins, tighten.
4. Remove the jackstands from under the chassis.
5. Operate the work platform over rough terrain and check for proper function and leaks.

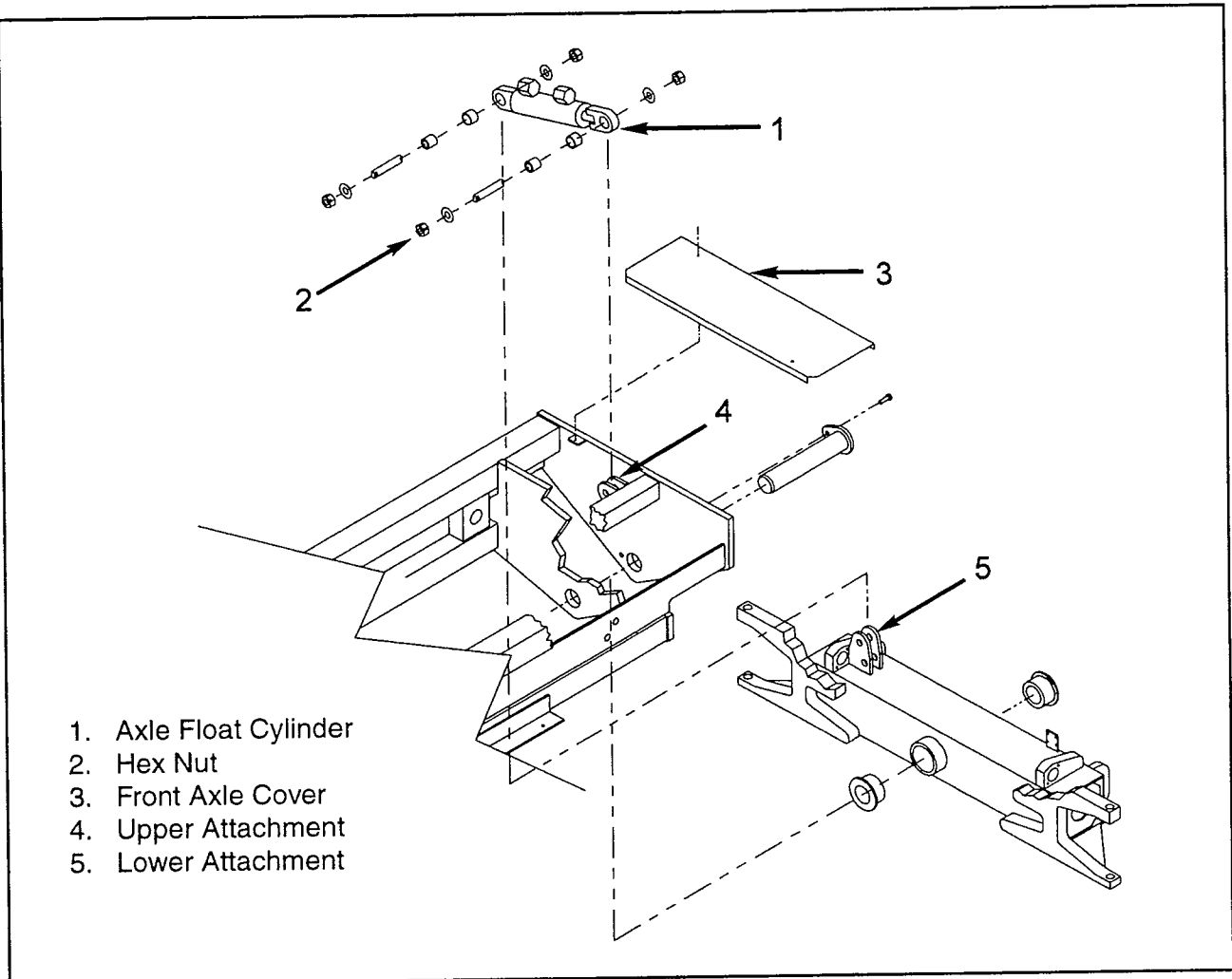

- 1. Axle Float Cylinder
- 2. Hex Nut
- 3. Front Axle Cover
- 4. Upper Attachment
- 5. Lower Attachment

Figure 3-25: Floating Axle Assembly

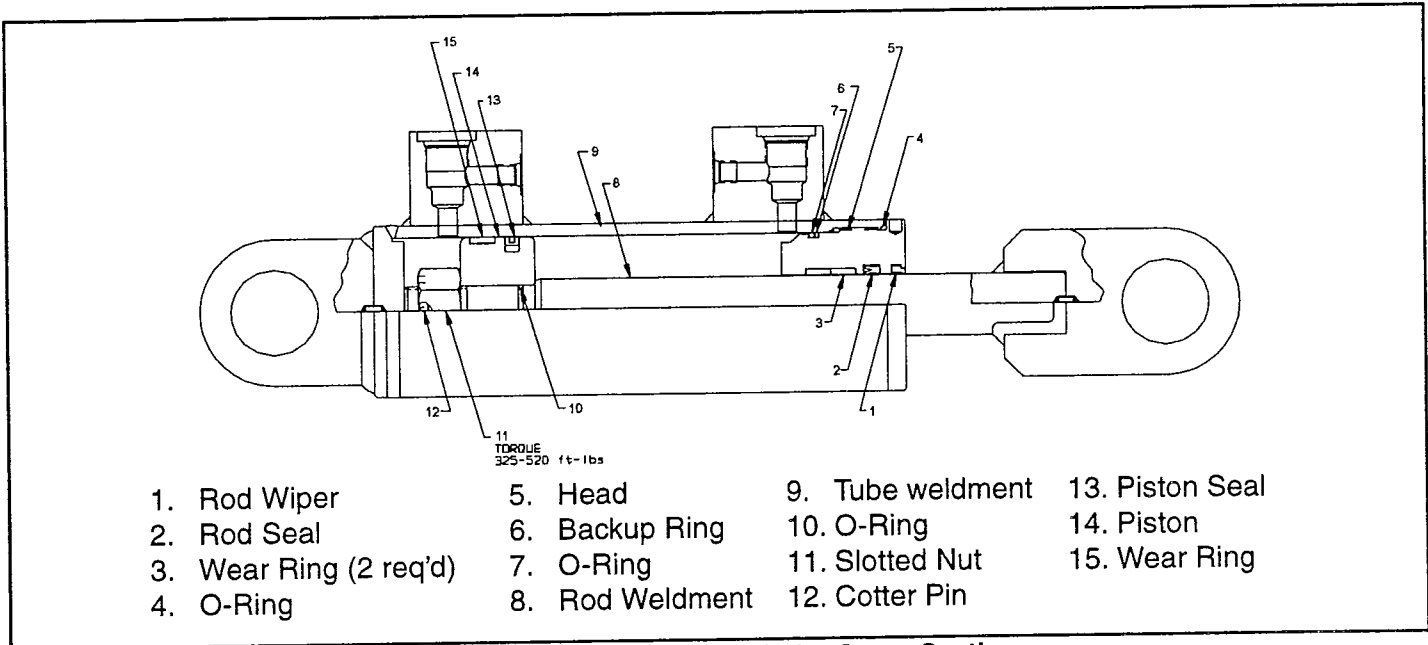

- | | | | |
|------------------------|-----------------|------------------|-----------------|
| 1. Rod Wiper | 5. Head | 9. Tube weldment | 13. Piston Seal |
| 2. Rod Seal | 6. Backup Ring | 10. O-Ring | 14. Piston |
| 3. Wear Ring (2 req'd) | 7. O-Ring | 11. Slotted Nut | 15. Wear Ring |
| 4. O-Ring | 8. Rod Weldment | 12. Cotter Pin | |

Figure 3-26: Axle Float Cylinder Cross Section

3.14 STEERING CYLINDER

Removal (Figure 3-27)

1. Remove the two capscrews holding the front axle cover in place (4WD only).
2. Remove and cap the hoses. Mark them for reference.
3. Remove the hair pin retainers from the clevis pins at each end of the cylinder.
4. Remove the clevis pins.
5. Remove the cylinder from the chassis.

Seal Replacement (Figure 3-28)

Note: Provide a clean work area for this operation, and observe clean assembly practices. Seals and hydraulic cylinder components are highly sensitive to contamination that may not even be visible to the naked eye.

1. Use a spanner wrench to rotate the head until the retaining ring becomes visible in the groove milled into the side of the cylinder. Insert a screwdriver under the beveled edge of the retaining ring to start it through the opening. Continue to rotate the head until the retaining ring works its way out of the opening.
2. Remove the rod, head, and piston from the tube.
3. Unscrew the locknut from the end of the rod.
4. Remove the piston from the rod.
5. Slide the rod out of the head.
6. Remove all of the old seals and wear rings, discard.
7. Thoroughly clean all parts with solvent. Rinse the inside of the tube and allow to drain. A high pressure rinse and wipe with a lint free rag is preferable.
8. Inspect the rod, head, piston, and tube for scratches, pits, or polishing. Check seal grooves and sealing surfaces. Scratches or pits deep enough to catch the fingernail are unacceptable, replace the affected component. Polishing is a sign of uneven loading, when this occurs, the surface should be checked for roundness. Surfaces not round within .007" should be replaced.
9. Lubricate all components and seals with clean hydraulic oil prior to assembly.

Note: During seal replacement steps, do not use sharp edged tools to avoid cutting the seals. After assembling all seals, allow at least one hour for the seals to elastically restore to their original shape before assembly.

bly. Refer to Figure 3-26 for component identification and placement.

10. Stretch the o-ring loader into the seal groove on the piston. Verify that it has not been twisted or pinched. Start one edge of the bidirectional piston seal into the groove in the piston and work it around into the groove with your thumbs. Be very careful not to cut the outer diameter of this seal.
11. Install the wear ring into the groove on the piston.
12. Twist the u-cup seal into a 'C' shape and snap it into the groove inside of the head. Note that the 'U' groove in the seal should face the inside of the cylinder.
13. Use the above technique to install the wiper into the groove inside the head. Note that the blade of the wiper should face toward the outside of the cylinder.
14. Install the static backup ring into the groove closest to the inside edge of the head.
15. Install the static o-ring into the above groove, making sure that it falls inside of the static backup ring.
16. Slide the head onto the rod.
17. Install the static o-ring onto the end of the rod.
18. Install the piston onto the rod.
19. Install the locknut onto the rod, torque to 250 ft.-lbs.
20. Slide the piston, rod, and head into the tube. Be careful not to damage any of the seals during assembly. If necessary, use shimstock to prevent the seals from extruding into the retaining ring slot.
21. Using a spanner wrench, rotate the head until the retaining ring hole is visible in the groove milled into the side of the cylinder. Insert the retaining ring hook into the hole and rotate the head 1-1/4 turns until the retaining ring is drawn completely into the tube and the ends are covered.

Installation

1. Align the ends of the cylinder with the mounts on the chassis.
2. Install the clevis pins.
3. Install the hair pin retainers into the clevis pins at each end of the cylinder.
4. Install the hoses, noting their orientation markings from disassembly.
5. Install the front axle cover and the two capscrews holding it in place, tighten (4WD only).

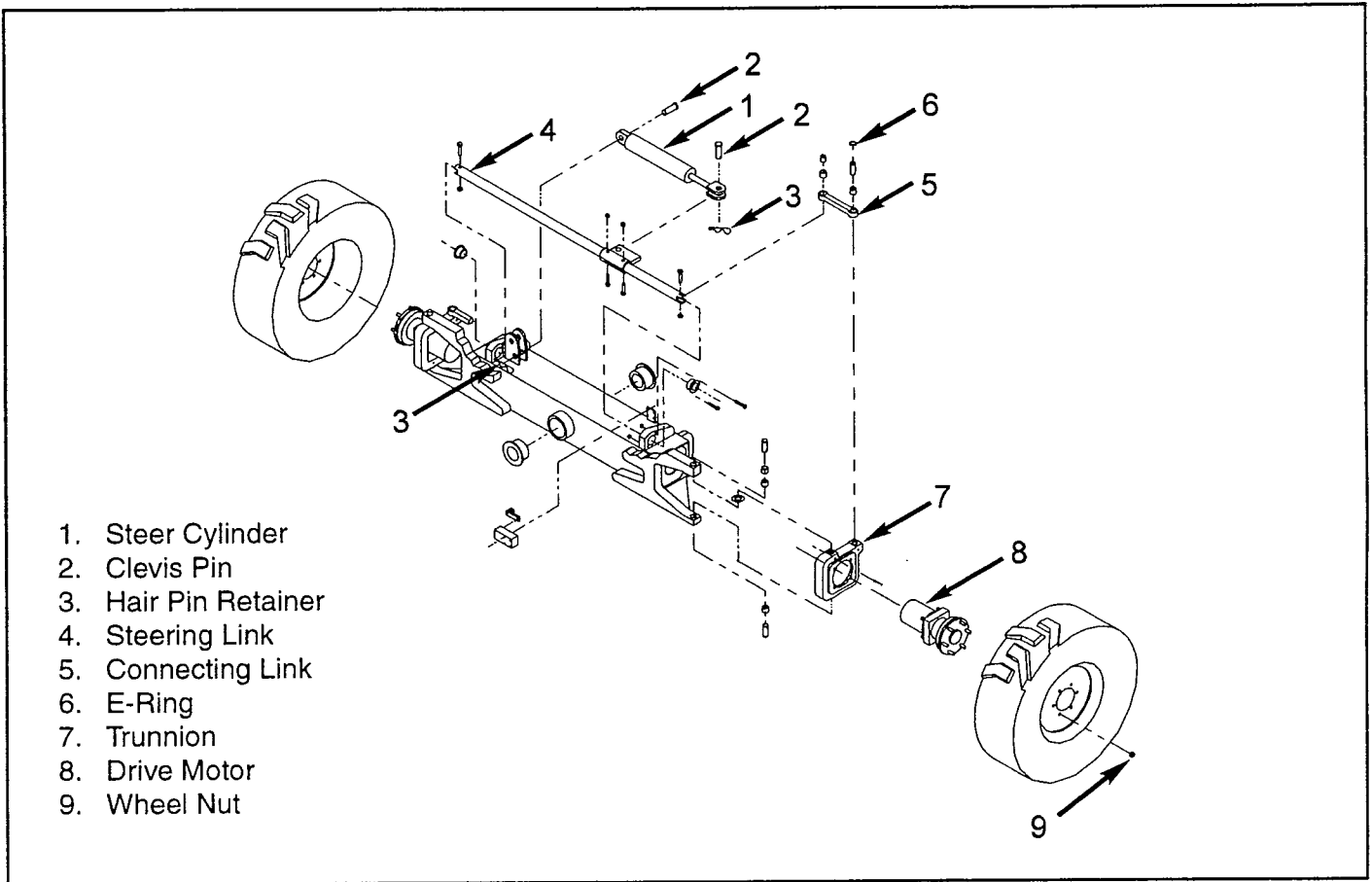

Figure 3-27: Front Axle Assembly, 4WD

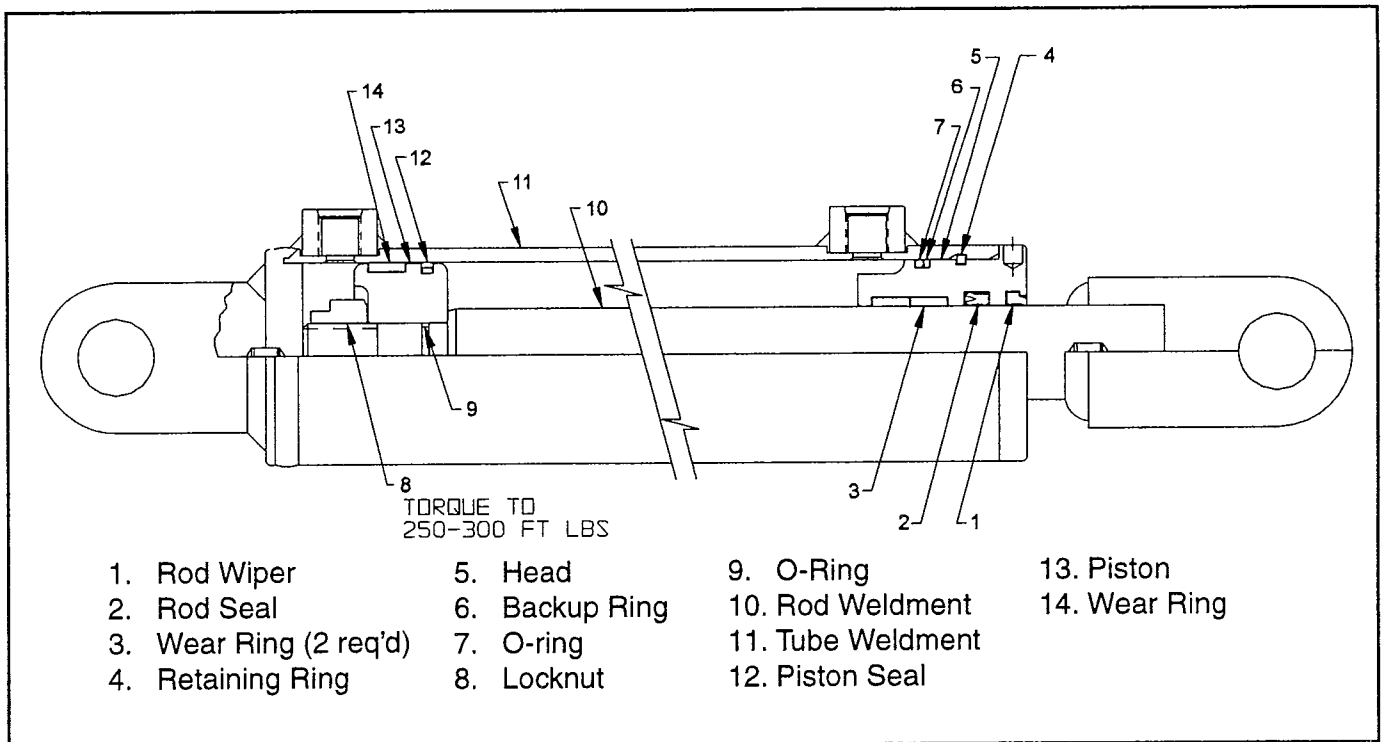

Figure 3-28: Steering Cylinder Cross Section

3.15 LIFT CYLINDERS

Removal (Figure 3-29)

1. Raise and block the elevating assembly (See Figure 3-6).
2. Open emergency lowering valve to be sure all pressure is out of the lift cylinder.
3. Remove and cap both hoses and fittings.
4. Remove the down valve and cable assembly.
5. Support the lift cylinder with a suitable lifting device to prevent falling.
6. Remove the retaining bolts from the upper and lower pivot pins.
7. Drive out the pivot pins, upper one first, then the lower one.
8. Hoist the cylinder out of the elevating assembly from the front. **DO NOT sling the cylinder by the rod end pivot, this will cause the cylinder to extend when hoisted.**

Seal Replacement (Figure 3-29)

Note: Provide a clean work area for this operation, and observe clean assembly practices. Seals and hydraulic cylinder components are highly sensitive to contamination that may not even be visible to the naked eye.

1. Use a spanner wrench to unscrew the head from the cylinder body tube.
 2. Carefully slide the rod, piston, and head out of the body tube and place on a clean surface.
 3. Unscrew the locknut from the rod end.
 4. Remove the piston from the rod.
 5. Slide the head off of the rod.
 6. Remove all of the old seals and wear rings, discard. Do not remove the cast iron ring from the piston.
 7. Thoroughly clean all parts with solvent. Rinse the inside of the tube and allow to drain. A high pressure rinse and wipe with a lint free rag is preferable.
 8. Inspect the rod, head, piston, and tube for scratches, pits, or polishing. Check seal grooves and sealing surfaces. Scratches or pits deep enough to catch the fingernail are unacceptable, replace the affected component. Polishing is a sign of uneven loading, when this occurs, the surface should be checked for roundness. Surfaces not round within .007" should be replaced.
 9. Inspect and clean the cushion orifice if any debris is present.
 10. Lubricate all components and seals with clean hydraulic oil prior to assembly.
- Note: During seal replacement steps, do not use sharp edged tools to avoid cutting the seals. After assembling all seals, allow at least one hour for the seals to elastically restore to their original shape before assembly. Refer to Figure 3-29 for component identification and placement.**
11. Separate the three components of the piston seal. Stretch the rubber inner ring over the piston and into the seal groove. Warm the teflon outer ring to 150°F using heated hydraulic fluid or water. Stretch the teflon outer ring into the seal groove. Clean the groove in the teflon ring and install the quad ring. Verify that none of the rings have twisted.
 12. Install the glass filled nylon wear rings into the outer grooves in the piston.
 13. Twist the u-cup seal into a 'C' shape and allow it to snap into the groove in the head.
 14. Use the above technique to install the wiper into the head.
 15. Install the static o-ring and the static backup ring into the groove in the head. Verify that the backup ring is closest to the threads.
 16. Install the sealing o-ring between the threads and the flange lip on the head, be careful not to damage the o-ring on the threads.
 17. Slide the head assembly onto the rod.
 18. Install the static o-ring into the groove on the rod.
 19. Install the piston onto the rod.
 20. Install the locknut and torque to 1125 ft.-lbs.
 21. Slide the piston, rod, and head into the tube. Be careful not to damage the piston seal on the threads during assembly. If necessary, use shim-stock to protect the piston seal when inserting.
 22. Use a spanner wrench to tighten the head.

Installation

Note: Before installing the cylinder, check the pins and bearings for excessive wear. Replace if necessary.

1. Using a suitable lifting device, lower the cylinder into the elevating assembly from the front. **DO NOT sling the cylinder by the rod end pivot, this will cause the cylinder to extend when hoisted.**
2. Align the pivots and install the pivot pins, lower one first, then the upper one.
3. Install the retaining bolts into the pivot pins.
4. Install the down valve and cable assembly. Adjust the cable to stop on the collar of the cable jacket, before the down valve reaches the full extent of it's pull. The down valve may leak if the cable is allowed to pull the spool of the valve beyond it's limit.
5. Install the hoses.
6. Lift and lower the machine for several cycles to work out the air. Check for leaks, repair as necessary.

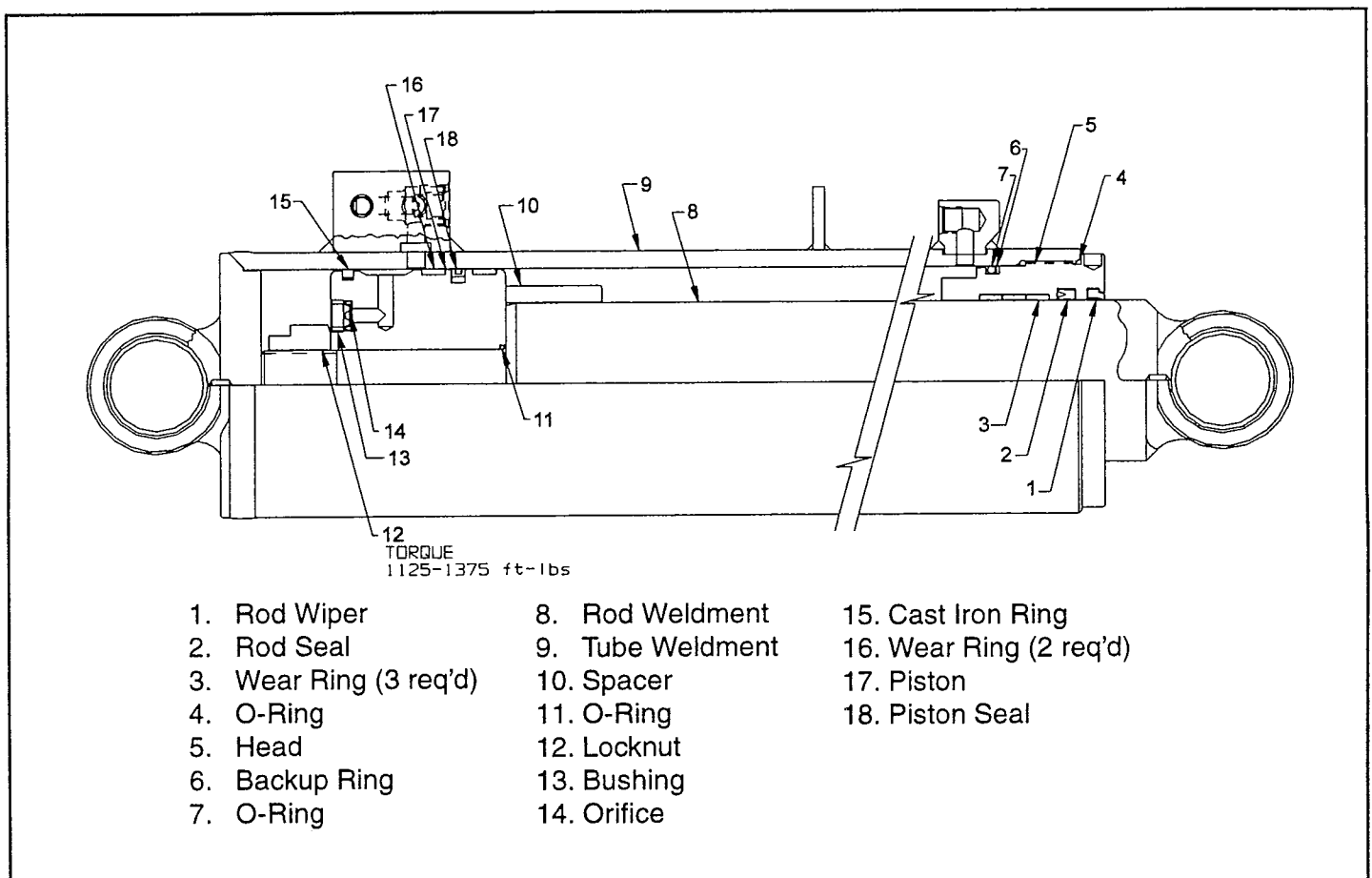

Figure 3-29: Lift Cylinder Cross Section

3.16 OUTRIGGER CYLINDER

Removal (Figure 3-30)

1. Remove the plug from the top of the outrigger cylinder.
2. Disconnect the wires from the pressure switch and the ball switch. Tag them for identification during reassembly.
3. Unscrew the strain relief and pull the wires out of the top of the cylinder.
4. Remove and cap the hoses. Tag them for identification during reassembly.
5. Remove the four capscrews, nuts, and washers holding the outrigger cylinder to the outrigger support weldment.
6. Remove the outrigger cylinder.

Seal Replacement (Figure 3-31)

Note: Provide a clean work area for this operation, and observe clean assembly practices. Seals and hydraulic cylinder components are highly sensitive to contamination that may not even be visible to the naked eye.

1. Clamp barrel assembly into vise, using aluminum sleeve to protect barrel from excessive scratches. Remove counterbalance valve from barrel assembly, use extreme caution valve is under pressure.
2. Unthread mount plate bolt from barrel assembly using a spanner wrench, a sharp impact on wrench is needed to loosen loctite from threads. Remove mount plate from end of rod.
3. Unthread retaining nut and remove from barrel assembly, using a spanner wrench.
4. Gently remove rod assembly from inside barrel assembly using extreme caution not to damage chrome plating on rod.
5. Remove seal retainer from rod assembly. Remove & discard all seals from seal retainer (rod wiper, rod seal, and static seal #1).
6. Clamp rod assembly in vise, using aluminum sleeve to protect chrome plating from damage. Drill out stakes on piston nut apply heat to threads on rod and piston, to loosen loctite on threads. Remove piston from rod assembly using spanner wrench.
7. Remove piston from rod, remove piston seal and discard.
8. Clean all components with cleaning solvent. Clean all Loctite from foot pad bolt.
9. Apply a light coating of hydraulic oil to all seals and sealing components prior to assembly.

Note: During seal replacement steps, do not use sharp edged tools to avoid cutting the seals. After assembling all seals, allow at least one hour for the seals to elastically restore to their original shape before assembly. Refer to Figure 3-31 for component identification and placement.

10. Install rod wiper by folding into a 'C' shape and allowing it to "snap" into the outer seal groove in the seal retainer.
11. Install rod seal into inner seal groove in seal retainer using above method.
12. Stretch static seal #1 into outer seal groove on seal retainer.
13. Stretch piston seal into seal groove on piston.
14. Install seal retainer onto rod assembly, from piston end of rod, using a sharp blow to seal retainer, with hard rubber mallet, to overcome seal squeeze.
15. Apply Loctite #262 (or equivalent) to rod end threads. Install piston onto rod end, torque using spanner wrench until tight.
16. Install rod assembly into barrel assembly, using extreme caution not to damage chrome plating on rod.
17. Seat seal retainer into barrel using a sharp blow with a hard rubber mallet to overcome seal squeeze.
18. Thread retaining nut onto barrel assembly, using spanner wrench, tighten.
19. Apply Loctite #242 (or equivalent) to threads of foot pad bolt.
20. While holding foot pad in place at end of rod, install foot pad bolt using spanner wrench, tighten.

Installation

1. Install the outrigger cylinder to the outrigger support weldment using the four capscrews, nuts, and washers; tighten.
2. Install the hoses exactly as disassembled.
3. Thread the wires for the pressure switch and the ball switch through the strain relief.
4. Reattach the wires to the switches exactly as disassembled.
5. Tighten strain relief.
6. Install plug to top of outrigger cylinder.

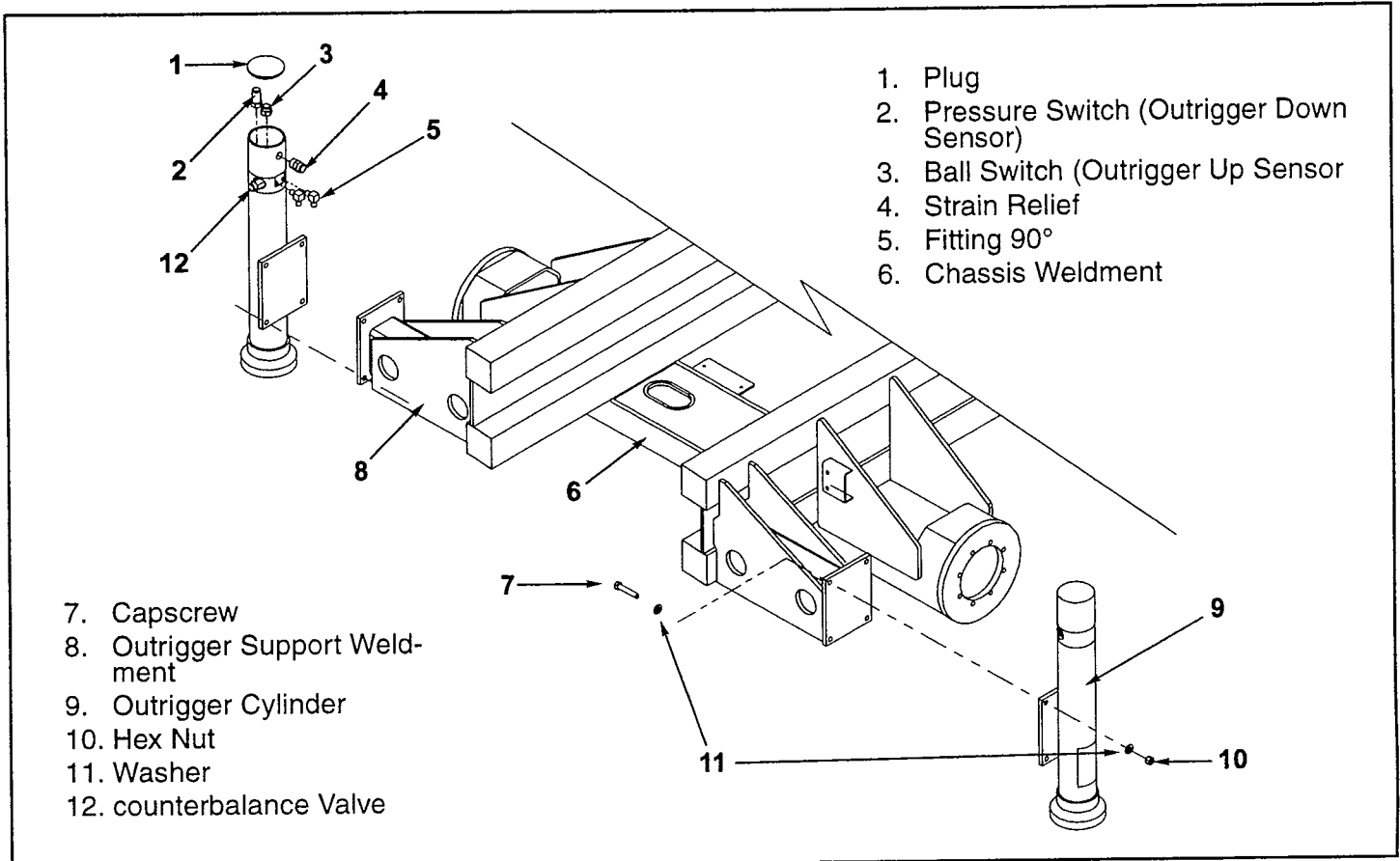

Figure 3-30: Outrigger Cylinder Installation

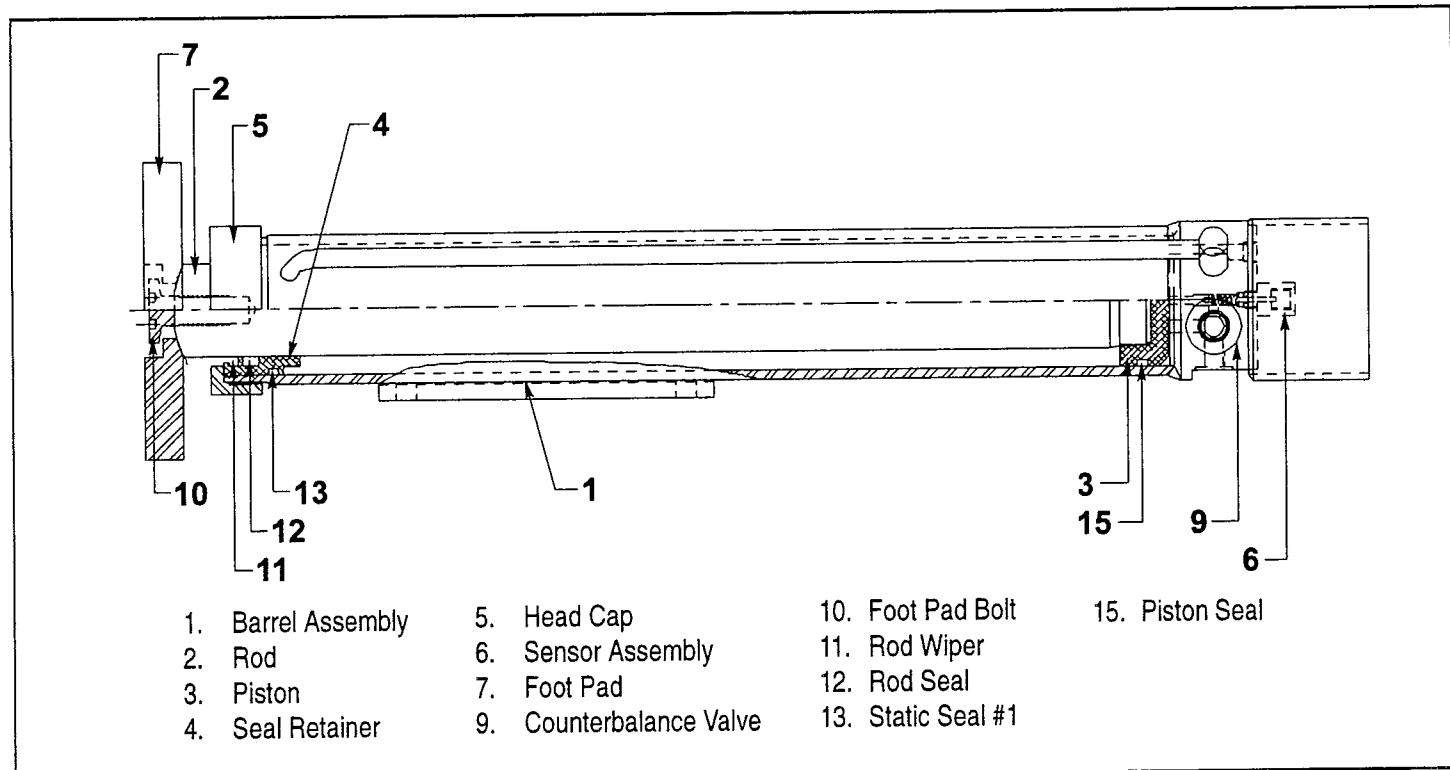

Figure 3-31: Outrigger Cylinder Cross Section

3.17 ENGINE ADJUSTMENTS

Use the following procedures to set engine speeds for gasoline, propane, and diesel engines. For complete service information on Kubota engines, consult the Kubota Work Shop Manual for your engine.

Dual Fuel Engine

Engine comes pre-adjusted from factory and should not need to be adjusted.

Gasoline Engine

Idle Speed (Figure 3-32)

1. Warm up the engine for 20 minutes and shut off.
2. Tighten the pilot screw of the carburetor completely, then loosen 1 to 1 1/2 turns. Do not over-tighten the pilot screw.
3. Start the engine. Release the throttle switch if it is engaged.
4. Back off on the throttle stop screw until the engine is barely running.
5. Adjust the pilot screw to achieve maximum RPM.
6. Adjust throttle stop screw until engine RPM reaches 1350 ± 50 .

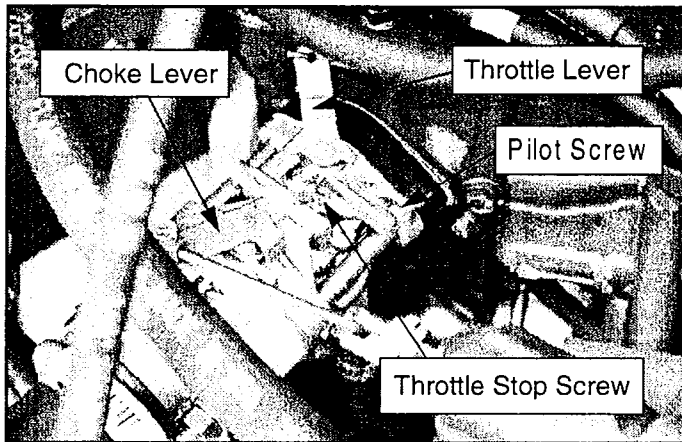

Figure 3-32: Gasoline Engine Carburetor

Governed High Speed

1. Loosen the locknut on the governor lever.
2. While pushing the throttle fully open with the governor lever, turn the governor shaft fully clockwise with a screwdriver.
3. Tighten the locknut in this position
4. Start the engine and depress the throttle button.
5. Adjust the high speed adjustment screw until the RPM reaches 3400 ± 50 .

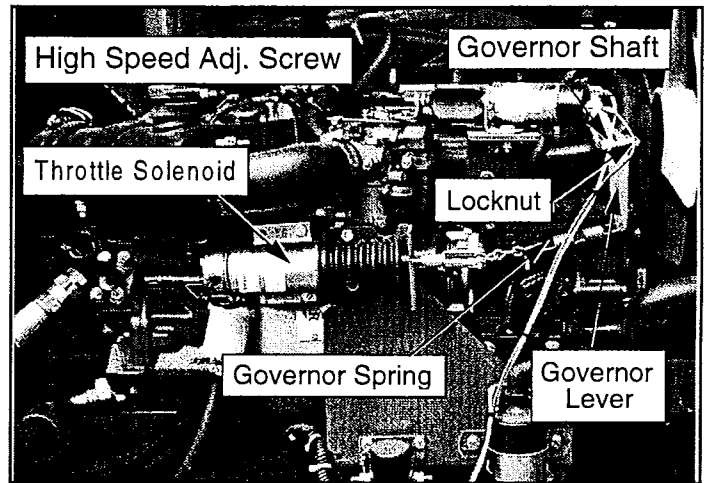

Figure 3-33: Gasoline Engine Governor

Diesel Engine

Idle Speed (Figure 3-34)

1. Warm up the engine for 20 minutes.
2. Depress the throttle button to put the engine in high speed.
3. Adjust the idle stop screw until the RPM reaches 1350 ± 50 .
4. Apply one drop of sealant to protect the adjustment from adjustment.

High Speed (Figure 3-34)

1. Warm up the engine for 20 minutes.
2. Depress the throttle button to put the engine in high speed.
3. Adjust the high speed screw until the RPM reaches 3000 ± 50 .
4. Apply one drop of sealant to protect the adjustment from vibration.

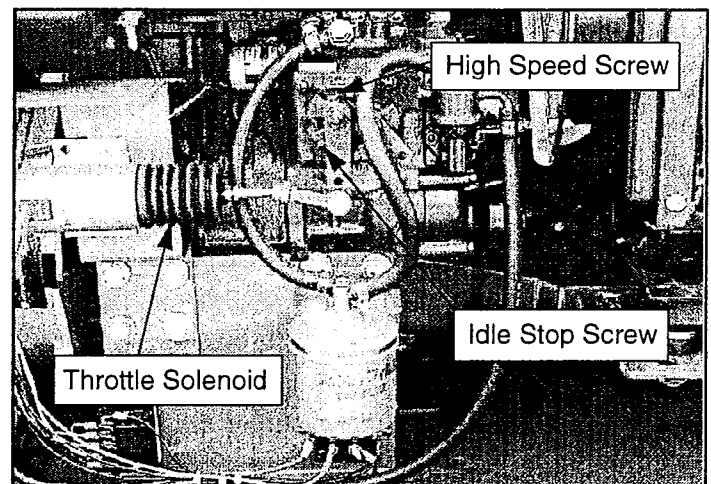

Figure 3-34: Diesel Engine

3.18 FILTER REPLACEMENT

Use the following procedures for replacing the engine air and fuel filters. Refer to Section 3.7, Lubrication for hydraulic and engine oil filter replacement procedures.

Gasoline/Propane Engine

Air Filter Element (Figure 3-35)

1. Unlock the two catches holding the filter canister closed.
2. Remove the wingnut from the filter assembly.
3. Remove and replace the air filter element.
4. Replace the wingnut, tighten.
5. Replace the cover and lock the catches.

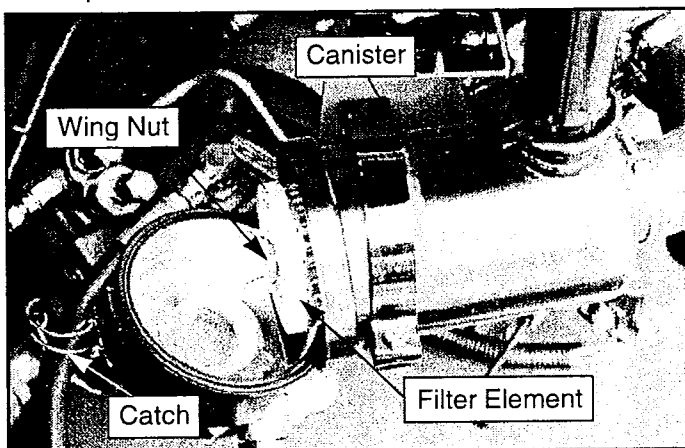

Figure 3-35: Gasoline Engine Air Filter

Fuel Filter (Figure 3-36)

1. Use a screwdriver to loosen the hose clamps on the fuel lines. Slide the clamps out of the way.
2. Remove the in-line filter from the two lines.
3. Replace the filter, noting the direction of fuel flow as shown by the arrow on the body of the filter.
4. Reposition the clamps, tighten.

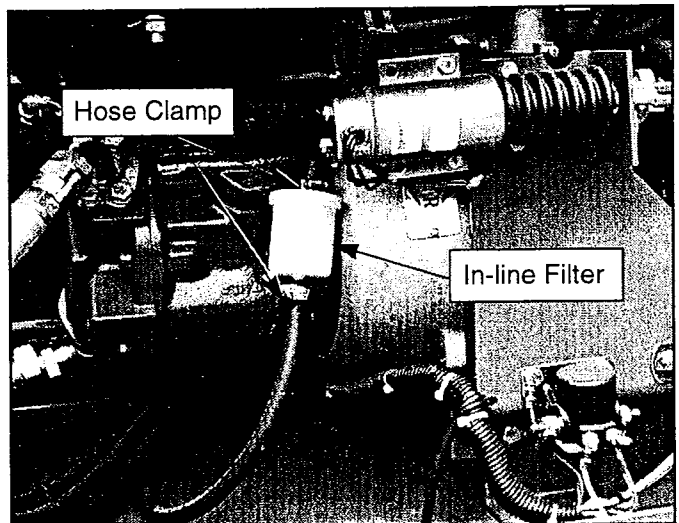

Figure 3-36: Gasoline Engine Fuel Filter

Diesel Engine

Air Filter Element (Figure 3-37)

1. Remove the wingbolt from the filter canister.
2. Remove and replace the filter element.
3. Replace the wingbolt, tighten.

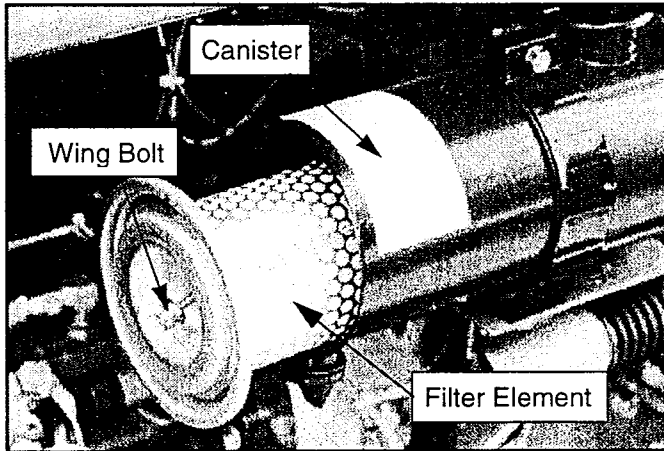

Figure 3-37: Diesel Engine Air Filter

Fuel Filter (Figure 3-38)

1. Provide a suitable container to catch spilled fuel, place under the fuel filter assembly.
2. Use a filter wrench to unscrew the fuel filter.
3. Remove and replace the filter.
4. Loosen the bleeder screw on the injector pump.
5. Operate the lift pump hand lever to pump fuel through the filter and up to the injector pump. Continue to pump until all of the air is bled from the system.
6. Tighten the bleeder screw.

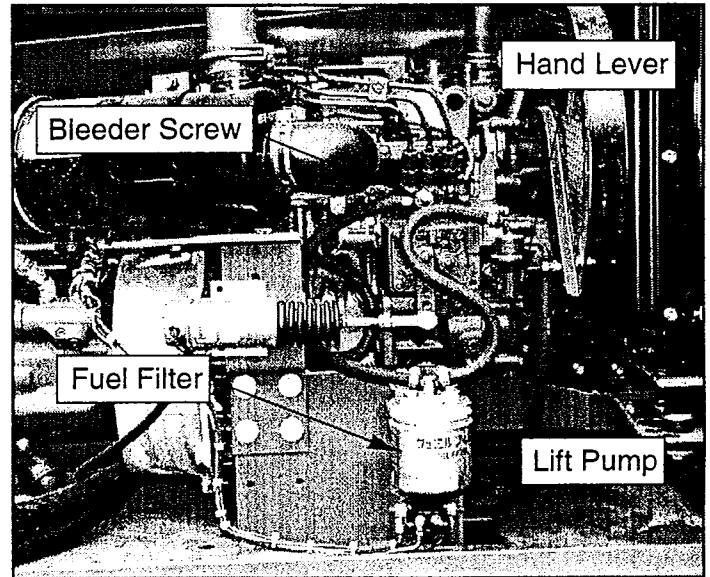

Figure 3-38: Diesel Engine Fuel Filter

3.19 TORQUE SPECIFICATIONS

Fasteners

Use the following values to torque fasteners used on UpRight Work Platforms unless a specific torque value is called out for the part being installed.

Hydraulic Components

Use the following values to torque hydraulic components used on UpRight Work Platforms.

Note: Always lubricate threads with clean hydraulic oil prior to installation

Table 3-3: Torque Specifications for Fasteners

AMERICAN STANDARD CAP SCREWS									METRIC CAP SCREWS								
SAE GRADE	5				8				METRIC GRADE	8.8				10.9			
Cap Screw Size (inches)									Cap Screw Size (millimeters)	8.8				10.9			
	TORQUE				TORQUE					TORQUE				TORQUE			
	Ft./Lbs		Nm.		Ft./Lbs.		Nm.			Ft./Lbs.		Nm.		Ft./Lbs.		Nm.	
	MIN	MAX	MIN	MAX	MIN	MAX	MIN	MAX		MIN	MAX	MIN	MAX	MIN	MAX	MIN	MAX
1/4 - 20	6.25	7.25	8.5	10	8.25	9.5	11	13	M6 x 1.00	6	8	8	11	9	11	12	15
1/4 - 28	8	9	11	12	10.5	12	14	16	M8 x 1.25	16	20	21.5	27	23	27	31	36.5
5/16 - 18	14	15	19	20	18.5	20	25	27	M10 x 1.50	29	35	39	47	42	52	57	70
5/16 - 24	17.5	19	23	26	23	25	31	34	M12 x 1.75	52	62	70	84	75	91	102	123
3/8 - 16	26	28	35	38	35	37	47.5	50	M14 x 2.00	85	103	115	139	120	146	163	198
3/8 - 24	31	34	42	46	41	45	55.5	61	M16 x 2.50	130	158	176	214	176	216	238	293
7/16 - 14	41	45	55.5	61	55	60	74.5	81	M18 x 2.50	172	210	233	284	240	294	325	398
7/16 - 20	51	55	69	74.5	68	75	92	102	M20 x 2.50	247	301	335	408	343	426	465	577
1/2 - 13	65	72	88	97.5	86	96	116	130	M22 x 2.50	332	404	450	547	472	576	639	780
1/2 - 20	76	84	103	114	102	112	138	152	M24 x 3.00	423	517	573	700	599	732	812	992
9/16 - 12	95	105	129	142	127	140	172	190	M27 x 3.00	637	779	863	1055	898	1098	1217	1488
9/16 - 18	111	123	150	167	148	164	200	222	M30 x 3.00	872	1066	1181	1444	1224	1496	1658	2027
5/8 - 11	126	139	171	188	168	185	228	251									
5/8 - 18	152	168	206	228	203	224	275	304									
3/4 - 10	238	262	322	355	318	350	431	474									
3/4 - 16	274	302	371	409	365	402	495	544									
7/8 - 9	350	386	474	523	466	515	631	698									
7/8 - 14	407	448	551	607	543	597	736	809									
1 - 8	537	592	728	802	716	790	970	1070									
1 - 14	670	740	908	1003	894	987	1211	1337									

NOTE: These values apply to fasteners as received from the supplier, dry or when lubricated with normal engine oil. They do not apply if special graphited or molydisulphide greases or other extreme pressure lubricants are used

Table 3-4: Torque Specifications for Hydraulic Components

Type: SAE Part Series	Cartridge Poppet		Fittings		Hoses	
	Ft/Lbs	Nm	Ft/Lbs	Nm	Ft/Lbs	Nm
#4	N/A	N/A	N/A	N/A	135-145	15-16
#6	N/A	N/A	10-20	14-27	215-245	24-28
#8	25-30	34-41	25-30	34-41	430-470	49-53
#10	35-40	47-54	35-40	47-54	680-750	77-85
#12	85-90	115-122	85-90	115-122	950-1050	107-119
#16	130-140	176-190	130-140	176-190	1300-1368	147-155

Notes:

Section 4

TROUBLESHOOTING

4.1 INTRODUCTION

The following section contains Troubleshooting Truth Tables that are to be used in conjunction with the Electrical Schematics in *Section 5*. Identify the symptom the machine exhibits and locate the corresponding component that may be the source of the problem.

Referring to *Section 2* and *Section 5* will aid in understanding the operation and function of the various components and systems of the LX50 and help diagnosing and repair of the machine. This manual cannot cover all possible problems that may occur. If a specific problem is not covered in this manual, call our toll free number for service assistance.

For Service assistance, in the U.S.A., call:
1-800-926-LIFT

From outside the U.S.A., call 1-559-896-5150

General Procedure

Troubleshooting should be carried out in two steps. First, thoroughly study both hydraulic and electric schematics to determine possible causes. Loose terminal connections and short circuits are always a potential cause when troubleshooting. Second, check suspect components electrically, hydraulically and mechanically to determine if they are at fault.

! WARNING !

When troubleshooting, ensure that the work platform is resting on a firm, level surface.

When performing any service which requires the Platform to be raised, the Elevating Assembly must be blocked (Figure 3-3).

Disconnect the battery ground cable when replacing or testing the continuity of any electrical component.

Electrical Truth Tables	page
Dual Fuel Models	4-2
Diesel Models	4-5
Outrigger Option.....	4-8

Hydraulic Truth Tables	
Two Wheel Drive Models	4-9
Four Wheel Drive Models.....	4-10
Two Wheel Drive Models w/ outriggers	4-11
Four Wheel Drive Models w/ outriggers.....	4-12

4.2 ELECTRICAL TRUTH TABLES

Table 4-1: Electrical Truth Table - Dual Fuel Models (2wd: 067535-054, 4wd: 067535-056)

COMPONENT		FUNCTION	MOTOR START & RUN	UPPER CONTROL FUNCTIONS	LOWER CONTROL FUNCTIONS	RAISE PLATFORM	LOWER PLATFORM	DRIVE FORWARD	DRIVE REVERSE	HIGH/LOW SPEED	STEER RIGHT	STEER LEFT	DOWN ALARM	TILT ALARM
ALM1	Alarm					X							X	X
ALT	Alternator	X												
BAT	Battery	X				X								
CB1	Circuit Breaker	X		X	X	X	X	X						
CB2	Circuit Breaker, Emergency Stop			X	X	X	X	X						
*CB3	Circuit Breaker			X										
*CB4	Circuit Breaker							X	X					
*CB5	Circuit Breaker							X	X	X				
*CB6	Circuit Breaker													
*CB7	Circuit Breaker							X	X	X				
*CB8	Circuit Breaker		X	X	X	X	X	X	X	X				
*CB10	Circuit Breaker		X	X										
*CB13	Circuit Breaker													
*CB14	Circuit Breaker													
CB15	Circuit Breaker			X										
D1	Diode	X												
D2,3	Diodes							X	X	X				
D4	Diode		X											
*D5-40,53	Diodes	Spike Protection												
DIST	Distributor	X												
FP	Fuel Pump	X												
J1	Jumper, Axle Float Setting			X										
J2	Jumper, 8 Meter Limit Setting				X		X	X	X					
J3	Jumper, Outrigger Setting				X		X	X	X					
J4	Jumper, Outrigger Setting				X		X	X	X					
L1	LED, Drive Enable	Indicates output from corresponding function from circuit board												
L3	LED, Forward													
L4	LED, Reverse													
L5	LED, Drive													
L6	LED, Up													
L7	LED, Torque													
L8	LED, Axle Float													
L9	LED, Down													
L10	LED, Steer Right													
L11	LED, Steer Left													
L12	LED, Throttle													
L13	LED, Choke													

TROUBLESHOOTING

COMPONENT		FUNCTION	MOTOR START & RUN	UPPER CONTROL FUNCTIONS	LOWER CONTROL FUNCTIONS	RAISE PLATFORM	LOWER PLATFORM	DRIVE FORWARD	DRIVE REVERSE	HIGH/LOW SPEED	STEER RIGHT	STEER LEFT	DOWN ALARM	TILT ALARM
PCB1	Circuit Board, Upper Controller			X		X		X	X					
PS1	Oil Pressure Switch		X											
*R1	Relay, Series Parallel							X	X	X				
*R2	Relay, Axle Float				X									
*R3	Relay, Down Alarm												X	
*R4	Relay, Steer Right										X			
*R5	Relay, Steer Left											X		
*R6	Relay, Throttle							X	X	X				
*R7	Relay, Up					X	X							
*R8	Relay, Choke			X	X	X	X	X	X	X				
*R10	Relay, Reverse								X					
*R11	Relay, Forward							X						
*R13	Relay, Platform Down					X	X							
*R14	Relay, Lift Cutout					X								
*R15	Relay, Drive Cutout							X	X	X				
*R16	Relay, PWM Cutout				X									
*R17-18	Relays, Drive							X	X	X				
*R19-20	Relays, Drive/Lift					X	X	X	X	X				
*R21	Relay, Power		X	X	X	X	X	X	X	X	X	X	X	X
R22	Relay, Throttle		X											
R30	Relay, Upper Control Power			X										
*R32	Relay, Start			X	X									
RES3	Resistor, Forward LED	Provides power to corresponding LED												
RES4	Resistor, Reverse LED													
RES5	Resistor, Drive LED													
RES6	Resistor, Up LED													
RES7	Resistor, Torque LED													
RES8	Resistor, Axle Float LED													
RES9	Resistor, Down LED													
RES10	Resistor, Steer Right LED													
RES11	Resistor, Steer Left LED													
RES12	Resistor, Throttle LED													
RES13	Resistor, Choke LED													
S1	Switch, Micro		X		X	X	X	X						
S2	Switch, Reverse Micro		X			X		X						
S3	Switch, Forward Micro		X		X		X							
S4	Switch, Micro Interlock		X		X	X	X	X		X	X			
S5	Switch, Steering Micro		X							X	X			
S6	Switch, Drive		X		X	X	X	X						
S7	Switch, Lift		X		X	X	X	X						

COMPONENT	FUNCTION	MOTOR START & RUN	UPPER CONTROL FUNCTIONS	LOWER CONTROL FUNCTIONS	RAISE PLATFORM	LOWER PLATFORM	DRIVE FORWARD	DRIVE REVERSE	HIGH/LOW SPEED	STEER RIGHT	STEER LEFT	DOWN ALARM	TILT ALARM
S8	Switch, Torque		X				X	X	X				
S9	Switch, Ignition	X											
S10	Switch, Choke	X											
S11	Switch, Emergency Stop	X											
S12	Switch, Gas	X											
S13	Switch, Propane	X											
S14	Switch, Starter	X											
S15	Switch, Choke	X											
S16	Switch, Engine Stop	X											
S17	Switch, Down			X		X							
S18	Switch, Lift			X	X								
S19	Switch, Throttle	X											
S20	Switch, Emergency Stop	X											
S21	Switch, Chassis/Platform		X	X									
S22-23	Switches, Platform Down								X				X
S24	Switch, Up Limit				X								
**S25	Switch, Axle Float						X	X	X				
SEN1	Sensor, Tilt				X				X				X
SOL1	Solenoid, Throttle	X											
SOL2	Solenoid, LP Shut-off	X											
SOL3	Solenoid, LP	X											
SOL4	Solenoid, Gasoline	X											
SOL5	Solenoid, Choke	X											
SOL6	Solenoid, Proportional				X		X	X					
SOL7	Solenoid, Forward						X						
SOL8	Solenoid, Reverse							X					
SOL9	Solenoid, Up				X								
**SOL10	Solenoid, Shunt						X	X	X				
SOL11	Solenoid, Series/Parallel						X	X	X				
**SOL12	Solenoid, Axle Float						X	X	X				
SOL13	Solenoid, Down					X							
SOL14	Solenoid, Steer Right									X			
SOL15	Solenoid, Steer Left										X		
SOL17	Solenoid, Series/Parallel						X	X	X				
STR	Starter	X											

* On Printed Circuit Board - not serviceable.

** For Four Wheel drive models only.

TROUBLESHOOTING

Section 4.2

Table 4-2: Electrical Truth Table - Diesel Models (2wd: 067535-055, 4wd: 067535-057)

COMPONENT		FUNCTION	MOTOR START & RUN	UPPER CONTROL FUNCTIONS	LOWER CONTROL FUNCTIONS	RAISE PLATFORM	LOWER PLATFORM	DRIVE FORWARD	DRIVE REVERSE	HIGH/LOW SPEED	STEER RIGHT	STEER LEFT	DOWN ALARM	TILT ALARM
ALM1	Alarm						X						X	X
ALT	Alternator		X											
BAT	Battery		X				X							
CB1	Circuit Breaker		X		X	X	X	X	X					
CB2	Circuit Breaker, Emergency Stop				X	X	X	X	X					
*CB3	Circuit Breaker				X									
*CB4	Circuit Breaker							X	X					
*CB5	Circuit Breaker							X	X	X				
*CB6	Circuit Breaker													
*CB7	Circuit Breaker							X	X	X				
*CB8	Circuit Breaker			X	X	X	X	X	X	X				
CB9	Circuit Breaker			X	X	X	X	X	X	X				
*CB10	Circuit Breaker			X	X									
*CB13	Circuit Breaker													
*CB14	Circuit Breaker													
CB15	Circuit Breaker				X									
D1	Diode		X											
D2,3	Diodes							X	X	X				
D4	Diode			X										
*D5-40,53	Diodes													
Spike Protection														
DIST	Distributor		X											
FP	Fuel Pump		X											
J1	Jumper, Axle Float Setting				X									
J2	Jumper, 8 Meter Limit Setting					X		X	X	X				
J3	Jumper, Outrigger Setting					X		X	X	X				
J4	Jumper, Outrigger Setting					X		X	X	X				
L1	LED, Drive Enable													
L3	LED, Forward													
L4	LED, Reverse													
L5	LED, Drive													
L6	LED, Up													
L7	LED, Torque													
L8	LED, Axle Float													
L9	LED, Down													
L10	LED, Steer Right													
L11	LED, Steer Left													
L12	LED, Throttle													
L13	LED, Glow Plug													
PCB1	Circuit Board, Upper Controller			X		X		X	X					

Indicates output from corresponding function from circuit board

COMPONENT		FUNCTION	MOTOR START & RUN	UPPER CONTROL FUNCTIONS	LOWER CONTROL FUNCTIONS	RAISE PLATFORM	LOWER PLATFORM	DRIVE FORWARD	DRIVE REVERSE	HIGH/LOW SPEED	STEER RIGHT	STEER LEFT	DOWN ALARM	TILT ALARM
PS1	Oil Pressure Switch		X											
*R1	Relay, Series Parallel							X	X	X				
*R2	Relay, Axle Float				X									
*R3	Relay, Down Alarm												X	
*R4	Relay, Steer Right										X			
*R5	Relay, Steer Left											X		
*R6	Relay, Throttle							X	X	X				
*R7	Relay, Up					X	X							
*R8	Relay, Glow			X	X	X	X	X	X	X				
*R10	Relay, Reverse								X					
*R11	Relay, Forward							X						
*R13	Relay, Platform Down					X	X							
*R14	Relay, Lift Cutout					X								
*R15	Relay, Drive Cutout							X	X	X				
*R16	Relay, PWM Cutout				X									
*R17-18	Relays, Drive							X	X	X				
*R19-20	Relays, Drive/Lift					X	X	X	X	X				
*R21	Relay, Power	X	X	X	X	X	X	X	X	X	X	X	X	X
R22	Relay, Throttle	X												
R23	Relay, Glow Plug	X												
R30	Relay, Upper Control Power			X										
*R32	Relay, Start			X	X									
RES1	Resistor, Glow Plugs	X												
RES3	Resistor, Forward LED	Provides power to corresponding LED												
RES4	Resistor, Reverse LED													
RES5	Resistor, Drive LED													
RES6	Resistor, Up LED													
RES7	Resistor, Torque LED													
RES8	Resistor, Axle Float LED													
RES9	Resistor, Down LED													
RES10	Resistor, Steer Right LED													
RES11	Resistor, Steer Left LED													
RES12	Resistor, Throttle LED													
RES13	Resistor, Glow Plug LED													
S1	Switch, Micro		X		X	X	X	X	X					
S2	Switch, Reverse Micro		X			X			X					
S3	Switch, Forward Micro		X		X			X						
S4	Switch, Micro Interlock		X		X	X	X	X			X	X		
S5	Switch, Steering Micro		X								X	X		
S6	Switch, Drive		X		X	X	X	X	X					

TROUBLESHOOTING

Section 4.2

COMPONENT	FUNCTION	MOTOR START & RUN	UPPER CONTROL FUNCTIONS	LOWER CONTROL FUNCTIONS	RAISE PLATFORM	LOWER PLATFORM	DRIVE FORWARD	DRIVE REVERSE	HIGH/LOW SPEED	STEER RIGHT	STEER LEFT	DOWN ALARM	TILT ALARM
S7	Switch, Lift		X		X	X	X	X					
S8	Switch, Torque		X				X	X	X				
S9	Switch, Ignition	X											
S10	Switch, Glow	X											
S11	Switch, Emergency Stop	X											
S14	Switch, Starter	X											
S15	Switch, Glow	X											
S16	Switch, Engine Stop	X											
S17	Switch, Down			X		X							
S18	Switch, Lift			X	X								
S19	Switch, Throttle	X											
S20	Switch, Emergency Stop	X											
S21	Switch, Chassis/Platform		X	X									
S22-23	Switches, Platform Down								X				X
S24	Switch, Up Limit				X								
**S25	Switch, Axle Float						X	X	X				
SEN1	Sensor, Tilt				X				X				X
SOL1	Solenoid, Throttle	X											
SOL5	Solenoid, Kubota Run	X											
SOL6	Solenoid, Proportional				X		X	X					
SOL7	Solenoid, Forward						X						
SOL8	Solenoid, Reverse							X					
SOL9	Solenoid, Up				X								
**SOL10	Solenoid, Shunt						X	X	X				
SOL11	Solenoid, Series/Parallel						X	X	X				
**SOL12	Solenoid, Axle Float						X	X	X				
SOL13	Solenoid, Down					X							
SOL14	Solenoid, Steer Right									X			
SOL15	Solenoid, Steer Left										X		
SOL17	Solenoid, Series/Parallel						X	X	X				
STR	Starter	X											

* On Printed Circuit Board - not serviceable.

** For Four Wheel drive models only.

Table 4-3: Electrical Truth Table - Outrigger Option

COMPONENT		FUNCTION	DEPLOY OUTRIGGERS	RETRACT OUTRIGGERS
CB11	Circuit Breaker		X	X
J3	Jumper, Outrigger Setting			
J4	Jumper, Outrigger Setting			
L14,16,18,20	LED, Outrigger Extend		X	
L15,17,19,21	LED, Outrigger Retract			X
PS2-5	Pressure Switches, Outrigger		X	
R24	Relay, Outrigger Extend (Right-Front)		X	
R25	Relay, Outrigger Retract (Right-Front)			X
R26	Relay, Outrigger Extend (Left-Front)		X	
R27	Relay, Outrigger Retract (Left-Front)			X
R28	Relay, Outrigger Extend (Right-Rear)		X	
R29	Relay, Outrigger Retract (Right-Rear)			X
R30	Relay, Outrigger Extend (Left-Rear)		X	
R31	Relay, Outrigger Retract (Left-Rear)			X
R32	Relay, Outrigger Power		X	X
*R33	Relay, Outrigger Pressure Switch Override			X
**R34	Relay, Override 2			
S27-30	Switches, Drive Interlock			X
S51	Switch, Outrigger Extend/Retract (Left-Front)		X	X
S52	Switch, Outrigger Extend/Retract (Left-Rear)		X	X
S53	Switch, Outrigger Extend/Retract (Right-Rear)		X	X
S54	Switch, Outrigger Extend/Retract (Right-Front)		X	X
SOL20	Solenoid, Outrigger Extend (Left-Front)		X	
SOL21	Solenoid, Outrigger Retract (Left-Front)			X
SOL22	Solenoid, Outrigger Extend (Right-Front)		X	
SOL23	Solenoid, Outrigger Retract (Right-Front)			X
SOL24	Solenoid, Outrigger Extend (Left-Rear)		X	
SOL25	Solenoid, Outrigger Retract (Left-Rear)			X
SOL26	Solenoid, Outrigger Extend (Right-Rear)		X	
SOL27	Solenoid, Outrigger Retract (Right-Rear)			X

4.3 HYDRAULIC TRUTH TABLES

Table 4-4: Hydraulic Truth Table - Two Wheel Drive Model (067534-014)

COMPONENT		FUNCTION	RAISE PLATFORM	LOWER PLATFORM	DRIVE FORWARD	DRIVE REVERSE	HIGH/LOW SPEED	STEER RIGHT	STEER LEFT	BRAKES
CP1	Cavity Plug				X	X	X			
CP2	Cavity Plug		X		X	X	X	X	X	X
CV1	Check Valve				X	X	X			
CYL1	Cylinder, Steering							X	X	
CYL2,3	Cylinders, Lift		X	X						
CYL4,5	Cylinders, Brake				X	X	X			X
MOT1,2	Motors, Rear Drive				X	X	X			
ORF1	Orifice, Steering							X	X	
ORF2,3	Orifices, Down			X						
ORF4	Orifice, Brake									X
P1	Pump, Hydraulic		X		X	X	X	X	X	X
P2	Pump, Brake Release									X
RV1	Relief Valve, Steering							X	X	
RV3	Relief Valve, Lift		X							
RV4,5	Relief Valves, Bi-Directional				X	X	X			
SV1	Shuttle Valve, Sense Line							X	X	
SV2	Shuttle Valve, Sense Line		X		X	X	X	X	X	
SV3	Shuttle Valve, Drive				X	X				
SV4	Shuttle Valve, Sense Line		X		X	X	X	X	X	
V1	Valve, Steering							X	X	
V2	Valve, Emergency Down			X						
V3	Valve, Proportional		X		X	X	X			
V4	Valve, Lift		X							
V5	Valve, Forward				X		X			
V6	Valve, Reverse					X	X			
V7	Valve, Reverse Counterbalance					X				
V8	Valve, Forward Counterbalance				X					
V9,10	Valves, Series/Parallel				X	X	X			
V11	Valve, Flow Divider				X	X	X			
V12,13	Valves, Down			X						
V14,15	Valves, Velocity Fuse			X						

Table 4-5: Hydraulic Truth Table - Four Wheel Drive Model (067534-015)

COMPONENT		FUNCTION	RAISE PLATFORM	LOWER PLATFORM	DRIVE FORWARD	DRIVE REVERSE	HIGH/LOW SPEED	STEER RIGHT	STEER LEFT	BRAKES
CP1	Cavity Plug				X	X	X			
CV1	Check Valve				X	X	X			
CYL1	Cylinder, Steering							X	X	
CYL2,3	Cylinder, Lift		X	X						
CYL4,5	Cylinders, Brake				X	X	X			
CYL6	Cylinder, Axle Float				X	X				
MOT1,2	Motors, Rear Drive				X	X	X			
MOT3,4	Motors, Front Drive				X	X	X			
ORF1	Orifice, Steering							X	X	
ORF2,3	Orifice, Down			X						
ORF4	Orifice, Brake									X
P1	Pump, Hydraulic		X		X	X	X	X	X	X
P2	Pump, Brake Release									X
RV1	Relief Valve, Steering							X	X	
RV3	Relief Valve, Lift		X							
RV4,5	Relief Valve, Bi-Directional				X	X	X			
SV1	Shuttle Valve, Sense Line							X	X	
SV2	Shuttle Valve, Sense Line		X		X	X	X	X	X	X
SV3	Shuttle Valve, Drive				X	X	X			X
SV4	Shuttle Valve, Sense Line		X		X	X	X	X	X	X
V1	Valve, Steering							X	X	
V2	Valve, Emergency Down			X						
V3	Valve, Proportional		X		X	X	X	X	X	
V4	Valve, Axle Float				X	X				
V5	Valve, Forward				X		X			
V6	Valve, Reverse					X				
V7	Valve, Reverse Counterbalance					X				
V8	Valve, Forward Counterbalance				X					
V9,10	Valves, Series/Parallel				X	X	X			
V11	Valve, Shunt				X	X	X			
V12,13	Valves, Down			X						
V14,15	Valves, Velocity Fuse			X						
V16	Valve, Lift		X							

TROUBLESHOOTING

Table 4-6: Hydraulic Truth Table - Two Wheel Drive Model w/ Outriggers (067534-016)

COMPONENT		FUNCTION	RAISE PLATFORM	LOWER PLATFORM	DRIVE FORWARD	DRIVE REVERSE	HIGH/LOW SPEED	STEER RIGHT	STEER LEFT	BRAKES	DEPLOY OUTRIGGERS
CP1	Cavity Plug				X	X	X	X	X		
CP2	Cavity Plug		X		X	X	X	X	X	X	
CV1	Check Valve				X	X	X				
CV3-6	Check Valves, Outrigger Sense Line										X
CYL1	Cylinder, Steering							X	X		
CYL2,3	Cylinders, Lift		X	X							
CYL4,5	Cylinders, Brake				X	X	X			X	
CYL6-9	Cylinders, Outrigger										X
MOT1,2	Motors, Rear Drive				X	X	X				
ORF1	Orifice, Steering							X	X		
ORF2,3	Orifice, Down			X							
ORF4	Orifice, Brake									X	
ORF5	Orifice, Outrigger										X
P1	Pump, Hydraulic		X		X	X	X	X	X	X	
P2	Pump, Brake Release									X	
RV1	Relief Valve, Steering							X	X		
RV3	Relief Valve, Lift		X	X							
RV4,5	Relief Valve, Bi-Directional				X	X	X				
SV1	Shuttle Valve, Sense Line							X	X		
SV2	Shuttle Valve, Sense Line		X		X	X	X	X	X		
SV3	Shuttle Valve, Drive				X	X					
SV4	Shuttle Valve, Sense Line		X		X	X	X	X	X		
V1	Valve, Steering							X	X		
V2	Valve, Emergency Down		X	X							
V3	Valve, Proportional		X		X	X	X				
V4	Valve, Lift		X								
V5	Valve, Forward				X		X				
V6	Valve, Reverse					X	X				
V7	Valve, Reverse Counterbalance					X					
V8	Valve, Forward Counterbalance				X						
V9,10	Valves, Series/Parallel				X	X	X				
V11	Valve, Flow Divider				X	X	X				
V12,13	Valves, Down			X							
V14,15	Valves, Velocity Fuse			X							
V19-22	Valve, Outrigger (Left Hand, Front)										X

TROUBLESHOOTING

Table 4-7: Hydraulic Truth Table - Four Wheel Drive Model w/ Outriggers (067534-017)

COMPONENT		FUNCTION	RAISE PLATFORM	LOWER PLATFORM	DRIVE FORWARD	DRIVE REVERSE	HIGH/LOW SPEED	STEER RIGHT	STEER LEFT	BRAKES	DEPLOY OUTRIGGERS
CV1	Check Valve				X	X	X				
CV3-6	Check Valves, Outrigger Sense Line										X
CP1	Cavity Plug				X	X	X				
CYL1	Cylinder, Steering							X	X		
CYL2,3	Cylinders, Lift		X	X							
CYL4,5	Cylinders, Brake				X	X	X				
CYL6-9	Cylinders, Outrigger										X
CYL10	Cylinder, Axle Float				X	X					
MOT1,2	Motors, Rear Drive				X	X	X				
MOT3,4	Motors, Front Drive				X	X	X				
ORF1	Orifice, Steering							X	X		
ORF2,3	Orifices, Down			X							
ORF4	Orifice, Brake									X	
ORF5	Orifice, Outrigger										X
P1	Pump, Hydraulic		X		X	X	X	X	X	X	
P2	Pump, Brake Release									X	
RV1	Relief Valve, Steering							X	X		
RV3	Relief Valve, Lift		X								
RV4,5	Relief Valves, Bi-Directional				X	X	X				
RV6-13	Relief Valves, Outrigger										X
SV1	Shuttle Valve, Sense Line							X	X		
SV2	Shuttle Valve, Sense Line		X		X	X	X	X	X	X	
SV3	Shuttle Valve, Drive				X	X	X			X	
SV4	Shuttle Valve, Sense Line		X		X	X	X	X	X	X	
V1	Valve, Steering							X	X		
V2	Valve, Emergency Down		X	X							
V3	Valve, Proportional		X		X	X	X	X	X		
V4	Valve, Lift		X								
V5	Valve, Forward				X		X				
V6	Valve, Reverse					X					
V7	Valve, Reverse Counterbalance					X					
V8	Valve, Forward Counterbalance				X						
V9,10	Valves, Series/Parallel				X	X	X				
V11	Valve, Shunt				X	X	X				
V12,13	Valves, Down			X							
V14,15	Valves, Velocity Fuse			X							
V19-22	Valves, Outrigger										X
V23	Valve, Axle Float				X	X					

Section 5

SCHEMATICS

5.1 INTRODUCTION

This section contains electrical and hydraulic power schematics and associated information for maintenance purposes.

The diagrams are to be used in conjunction with the *Troubleshooting Truth Tables* in *Section 4*. They allow understanding of the makeup and functions of the systems for checking, tracing, and faultfinding during troubleshooting analysis.

The components that comprise the electrical and hydraulic systems are given a reference designation and are explained as to function and location in the following tables.

Schematics	Page
Figure 5-1: Electrical Schematic: Two Wheel Drive, Dual Fuel - 067535-054 (1 of 2)	5-4
Figure 5-2: Electrical Schematic: Two Wheel Drive, Dual Fuel - 067535-054 (2 of 2)	5-5
Figure 5-3: Electrical Schematic: Two Wheel Drive, Diesel - 067535-055 (1 of 2)	5-8
Figure 5-4: Electrical Schematic: Two Wheel Drive, Diesel - 067535-055 (2 of 2)	5-9
Figure 5-5: Electrical Schematic: Four Wheel Drive, Dual Fuel - 067535-056 (1 of 2)	5-12
Figure 5-6: Electrical Schematic: Four Wheel Drive, Dual Fuel - 067535-056 (2 of 2)	5-13
Figure 5-7: Electrical Schematic: Four Wheel Drive, Diesel - 067535-057 (1 of 2)	5-16
Figure 5-8: Electrical Schematic: Four Wheel Drive, Diesel - 067535-057 (2 of 2)	5-17
Figure 5-9: Electrical Schematic: Outrigger Option (1 of 3)	5-19
Figure 5-10: Electrical Schematic: Outrigger Option (2 of 3)	5-20

Figure 5-11: Electrical Schematic: Outrigger Option (3 of 3)	5-21
Figure 5-12: Hydraulic Schematic: Two Wheel Drive (067534-014)	5-23
Figure 5-13: Hydraulic Schematic: Four Wheel Drive (067534-015)	5-25
Figure 5-14: Hydraulic Schematic: Two Wheel Drive w/ outriggers (067534-016)	5-27
Figure 5-15: Hydraulic Schematic: Four Wheel Drive w/ outriggers (067534-017)	5-29

Tables	Page
Table 1: Electrical Schematic Legend: Two Wheel Drive, Dual Fuel Model (067535-054)	5-2
Table 2: Electrical Schematic Legend: Two Wheel Drive, Diesel Model (067535-055)	5-6
Table 3: Electrical Schematic Legend: Four Wheel Drive, Dual Fuel Model (067535-056)	5-10
Table 4: Electrical Schematic Legend: Four Wheel Drive, Diesel Model (067535-057)	5-14
Table 5: Electrical Schematic Legend: Outrigger Option	5-18
Table 6: Hydraulic Schematic Legend: Two Wheel Drive Models (067534-014)	5-22
Table 7: Hydraulic Schematic Legend: Four Wheel Drive Models (067534-015)	5-24
Table 8: Hyd. Schematic Legend: 2WD Drive Models w/Outrigger Option (067534-016)	5-26
Table 9: Hyd. Schematic Legend: 4WD Drive Models w/Outrigger Option (067534-017)	5-28

5.1 ELECTRICAL SCHEMATIC

Table 1: Electrical Schematic Legend: Two Wheel Drive, Dual Fuel Model (067535-054)

DESIG-NATION	NAME	FUNCTION	LOCATION
ALM1	Alarm	Provides warning sound when slope of machine exceeds 3° side-to-side, or fore and aft and also when deck is lowering.	Chassis Body
ALT	Alternator	Maintains current during operation.	Power Module
BAT	Battery	Provides power for starting engine.	Power Module
CB1	Circuit Breaker, Power	Supplies power to all function solenoids.	Lower Controls
CB2	Circuit Breaker, Emergency Stop	Supplies power to Upper Control ignition switch	Lower Controls
CB3	Circuit Breaker	Supplies power to Lower Controls	Power Module
CB4	Circuit Breaker	Supplies power to Relay R11	On Relay R11
CB5	Circuit Breaker	Supplies power to Relay R1	On Relay R1
CB6	Circuit Breaker	Supplies power to Relay R2	On Relay R2
CB7	Circuit Breaker	Supplies power to Relay R6	On Relay R6
CB8	Circuit Breaker	Supplies power to Relay R8	On Relay R8
CB9	Circuit Breaker	Overcurrent protection	Control Module
CB10	Circuit Breaker	Supplies power to relay R32	On Relay R32
CB13	Circuit Breaker	Supplies power to Outtrigger option switches S36-38.	On Switch S37
CB14	Circuit Breaker	Supplies power to Outtrigger option switches S39-41.	On Switch S40
CB15	Circuit Breaker	Supplies power to Lower Controls	Lower Controls
D1	Diode	Spike Protection	Power Module
D2	Diode	Spike Protection	Power Module
D3	Diode	Spike Protection	Power Module
D4	Diode	Spike Protection	Upper Controls
D5	Diode	Spike Protection	Lower Controls
D6	Diode	Spike Protection	Lower Controls
D7	Diode	Spike Protection	Lower Controls
D8	Diode	Spike Protection	Control Module
D9	Diode	Spike Protection	Control Module
D10	Diode	Spike Protection	On Relay R20
D11	Diode	Spike Protection	On Relay R18
D12	Diode	Spike Protection	On Relay R17
D13-16	Diodes	Spike Protection	On Relay R16
D17	Diode	Spike Protection	
D18	Diode	Spike Protection	On Relay R13
D19	Diode	Spike Protection	
D20	Diode	Spike Protection	On Relay R32
D21	Diode	Spike Protection	On Relay R11
D22	Diode	Spike Protection	On Relay R10
D23	Diode	Spike Protection	On Relay R7
D24	Diode	Spike Protection	On Relay R1
D25	Diode	Spike Protection	On Relay R2
D26	Diode	Spike Protection	On Relay R3

DESIG-NATION	NAME	FUNCTION	LOCATION
D27	Diode	Spike Protection	On Relay R4
D28	Diode	Spike Protection	On Relay R5
D29	Diode	Spike Protection	On Relay R6
D30	Diode	Spike Protection	On Relay R8
D31	Diode	Spike Protection	On Relay R11
D32	Diode	Spike Protection	On Relay R10
D33	Diode	Spike Protection	On Relay R7
D34	Diode	Spike Protection	On Relay R1
D35	Diode	Spike Protection	On Relay R2
D36	Diode	Spike Protection	On Relay R3
D37	Diode	Spike Protection	On Relay R4
D38	Diode	Spike Protection	On Relay R5
D39	Diode	Spike Protection	On Relay R6
D40	Diode	Spike Protection	On Relay R8
D41-44	Diodes	Spike Protection	On Motion Dip Switch
D45	Diode, 10V	Spike Protection	Control Module
D46	Diode	Spike Protection for Alarm	Control Module
D47	Diode	Spike Protection for Alarm	Control Module
D48	Diode, 5V	Spike Protection for Alarm	Control Module
D49	Diode, 10V	Spike Protection for Alarm	Control Module
D50	Diode	Spike Protection for Alarm	Control Module
D51	Diode	Spike Protection for Alarm	Control Module
D52	Diode, 28V	Spike Protection	Control Module
D53	Diode	Spike Protection	On Relay R21
HM	Hour Meter	Counts hours machine is operated	Lower Controls
J1	Axle Float Setting Jumper	Axle Float Settings	Lower Controls
J2	8 Meter Limit Setting Jumper	8 meter cutout settings.	Lower Controls
J3	Outtrigger Setting Jumper	Outtrigger functions.	Lower Controls
J4	Outtrigger Setting Jumper	Outtrigger functions.	Lower Controls
L1	Drive Enable LED	Indicates drive enabled	Upper Controls
L3	Forward LED	Indicates Forward functions being used	Circuit Board
L4	Reverse LED	Indicates Reverse functions being used	Circuit Board
L5	Drive LED	Indicates Drive functions being used	Circuit Board
L6	Up LED	Indicates Up functions being used	Circuit Board
L7	Torque LED	Indicates Torque functions being used	Circuit Board
L8	Axle Float LED	Not Used	Circuit Board
L9	Down LED	Indicates Down functions being used	Circuit Board
L10	Steer Right LED	Indicates Steer Right functions being used	Circuit Board

Section 6

ILLUSTRATED PARTS BREAKDOWN

Introduction

This section lists and illustrates the replaceable assemblies and parts of this product, as manufactured by UpRight, Inc. Each parts list contains the component parts for that assembly.

CONTENTS

Final Assembly, LX50 Two-Wheel Drive Dual Fuel, Standard Deck 067546-010	6 - 4	Scissor Linkage Assembly, LX50 067424-000	6 - 44
Final Assembly, LX50 Two-Wheel Drive Diesel, Standard Deck 067547-010	6 - 8	Controller Assembly, LX50 w/o Outriggers 067528-010	6 - 46
Final Assembly, LX50 Four-Wheel Drive Dual Fuel, Standard Deck 067548-010	6 - 12	Controller Assembly, LX50 w/ Outriggers 067528-011	6 - 48
Final Assembly, LX50 Four-Wheel Drive Diesel, Standard Deck 067549-010	6 - 16	Control Module Assembly, LX50 Two-Wheel Drive Dual Fuel, Standard Deck 067521-020	6 - 50
Final Assembly, LX50 Two-Wheel Drive Dual Fuel, Dual Deck 067408-010	6 - 20	Control Module Assembly, LX50 Two-Wheel Drive Diesel, Standard Deck 067521-021	6 - 52
Final Assembly, LX50 Two-Wheel Drive Diesel, Dual Deck 067409-010	6 - 24	Control Module Assembly, LX50 Four-Wheel Drive Dual Fuel, Standard Deck 067521-022	6 - 54
Final Assembly, LX50 Four-Wheel Drive Dual Fuel, Dual Deck 067410-010	6 - 28	Control Module Assembly, LX50 Four-Wheel Drive Diesel, Standard Deck 067521-023	6 - 56
Final Assembly, LX50 Four-Wheel Diesel, Dual Deck 067411-010	6 - 32	Control Module Assembly, LX50 Two-Wheel Drive Dual Fuel, Dual Deck 067521-028	6 - 58
Basic Assembly, LX50 Two/Four Wheel Drive, Standard Deck 2WD: 067508-001, 4WD: 067509-001	6 - 36	Control Module Assembly, LX50 Two-Wheel Drive Diesel, Dual Deck 067521-029	6 - 60
Basic Assembly, LX50 Two/Four Wheel Drive, Dual Deck 2WD: 067419-000, 4WD: 067420-000	6 - 38	Control Module Assembly, LX50 Four-Wheel Drive Dual Fuel, Dual Deck 067521-030	6 - 62
Chassis Assembly, LX50 Two-Wheel Drive 067518-001	6 - 40	Control Module Assembly, LX50 Four-Wheel Drive Diesel, Dual Deck 067521-031	6 - 64
Chassis Assembly, LX50 Four-Wheel Drive 067519-001	6 - 42	Control Cable Assembly, LX50 067536-012	6 - 70

Power Module, LX50 Two-Wheel Drive, Dual Fuel 067522-010.....	6 - 72	Guardrail Installation, LX50 Dual Deck 030841-300	6 - 104
Power Module, LX50 Four-Wheel Drive, Dual Fuel 067522-011.....	6 - 74	Valve Manifold Assembly, LX50 2WD: 067489-000, 4WD: 067489-001	6 - 106
Power Module, LX50 Two-Wheel Drive, Diesel 067522-012.....	6 - 76	Fuel tank Assembly, LX50 Dual Fuel 067485-000	6 - 108
Power Module, LX50 Two-Wheel Drive, Diesel 067522-013.....	6 - 78	Fuel Tank Assembly, LX50 Diesel 067485-001	6 - 109
Engine Assembly, LX50 Kubota Dual Fuel 067523-010.....	6 - 80	Wire Harness, LX50 Main Control 067492-001	6 - 110
Engine Assembly, LX50 Kubota Diesel 067523-011.....	6 - 82	Wire Harness, LX50 Valve Block 067492-002	6 - 112
Hose Kit Installation, LX50 Two-Wheel Drive, w/o Outriggers 067533-022.....	6 - 86	Wire Harness, LX50 Dual Fuel Engine 067492-004	6 - 114
Hose Kit Installation, LX50 Four-Wheel Drive, w/o Outriggers 067533-023.....	6 - 88	Wire Harness, LX50 Diesel Engine 067492-005	6 - 116
Hose Kit Installation, LX50 Two-Wheel Drive, w/Outriggers 067533-024.....	6 - 90	Wire Harness, LX50 Outrigger Extension 067492-006	6 - 118
Hose Kit Installation, LX50 Four-Wheel Drive, w/Outriggers 067533-025.....	6 - 92	Wire Harness, LX50 Engine Extension 067492-012	6 - 120
Label Kit Installation, LX50 2-Wheel Drive Dual Fuel/Diesel, Stand. Deck D/F: 067532-142, Diesel: 067532-143.....	6 - 94	Outrigger Option, LX50 Dual Fuel/Diesel D/F: 067950-010, Diesel: 067950-011	6 - 122
Label Kit Installation, LX50 4-Wheel Drive Dual Fuel/Diesel, Stand. Deck D/F: 067532-144, Diesel: 067532-145.....	6 - 96	Slide-Out Deck Extension, LX50 Standard Deck Only 067866-001	6 - 126
Label Kit Installation, LX50 2-Wheel Drive Dual Fuel/Diesel, Dual Deck D/F: 067532-128, Diesel: 067532-129.....	6 - 98	Power To Platform Option LX50 067907-012	6 - 128
Label Kit Installation, LX50 4-Wheel Drive Dual Fuel/Diesel, Dual Deck D/F: 067532-130, Diesel: 067532-131.....	6 - 100	Motion Alarm Option LX50 067909-010	6 - 129
Guardrail Installation, LX50 Standard Deck 067530-005.....	6 - 102	Amber Beacon Option LX50 067947-010	6 - 130

ILLUSTRATED PARTS BREAKDOWN

Horn Option

LX50
067908-000..... 6 - 131

AC Generator Option,

Dual Fuel
067848-000..... 6 - 132

AC Generator Option

Diesel
067849-000 6 - 134

Removable Controller Option

LX50
061898-002 6 - 136

NOTES:

**Section
6.1**

ILLUSTRATED PARTS BREAKDOWN

**FINAL ASSEMBLY, LX50 TWO-WHEEL DRIVE
DUAL FUEL, STANDARD DECK
067546-010**

ITEM	PART NO.	DESCRIPTION	QTY.
1	067508-001	BASIC ASSY	1
2	067528-010	CONTROLLER ASSY	1
3	067536-012	CONTROL CABLE ASSY	1
4	067532-142	LABEL-KIT	1
5	067533-022	HOSE-KIT	1
6	067530-005	GUARDRAIL	1
7	067522-010	POWER MODULE ASSEMBLY	1
8	067521-020	CONTROL MODULE ASSEMBLY	1
9	067534-014	HYDRAULIC SCHEMATIC	REF
10	067535-054	ELECTRICAL SCHEMATIC	REF
11	067692-000	CLIP, CABLE RETAINER	4
14	029945-013	LEVEL SENSOR	1
15	011252-006	SCRW, 1/4-20 X 3/4	4
16	011248-004	LOCKNUT, 1/4-20 UNC	8
17	065373-005	MAGNET	2

ITEM	PART NO.	DESCRIPTION	QTY.
18	065373-006	SWITCH	2
19	067913-000	ALUM. SW. PAD	1
20	026551-005	RIVET 1/8 X 1/4 GRIP	8
21	029490-099	CABLE, 2 COND. 16 AWG	30 FT
22	029620-002	CONN. BUTT 16-14 AWG	12
23	063497-001	MERCURY SWITCH	1
24	013919-013	CLAMP	1
25	014996-004	WASHER, 1/4 SAE FLAT	4
26	067492-003	WIRE HARNESS, ENGINE EXTENSION	1
27	013283-002	CABLE MOUNT	4
28	020398-012	CLAMP, CUSHIONED, Ø 1 1/2	4
29	012865-099	WIRE LOOM 3/4 DIA	8 FT
30	067863-000	SWITCH MOUNT	1
31	067758-099	NYLON HOSE GUARD	3 FT
32	029931-003	CONN. FEMALE PUSH, 16-14 GA., .25 TAB	2

NOTES:

1. HYDRAULIC PRESSURE SETTING
FORWARD COUNTER BALANCE - 800 PSI
REVERSE COUNTER BALANCE - 800 PSI
DRIVE MOTOR RELIEF - 3000 PSI
STEERING - 1500 PSI
2. ENGINE SPEED
FULL THROTTLE - 3400 ±50 RPM
IDLE SPEED - 1350 ±50 RPM
3. DRIVE SPEED
SLOW - .30-.35 MPH (38-45 SEC. @ 20 FT.)
HIGH - 2.9-3.1 MPH (4.4-4.7 SEC. @ 20 FT.)
4. LIFT SPEED
UP - 80 SECONDS DOWN - 75 SECONDS
5. PROOF LOAD - 1500 LBS.
6. RATED LOAD - 1000 LBS./455 KG.
7. GRADABILITY 24% MIN. (2900 LBS. DRAWBAR PULL)
8. CAUTION:
MAKE SURE THAT PUMP IS FILLED WITH HYDRAULIC OIL PRIOR TO OPERATION, OR SERIOUS DAMAGE WILL OCCUR.
9. CHECK TIRE PRESSURE (10-16.5 NHS 8 PLY) @ 50 PSI
- 10.
11. SET MERCURY SWITCH (UP LIMIT) TO OPEN AT SPECIFIED DIMENSION TO PREVENT FULL EXTENSION OF LIFT CYL.
12. SET SWITCH TO OPEN LESS THAN 2 FT. PLATFORM LIFT.
13. BLEED AIR OUT OF BRAKES.

Section
6.1

ILLUSTRATED PARTS BREAKDOWN

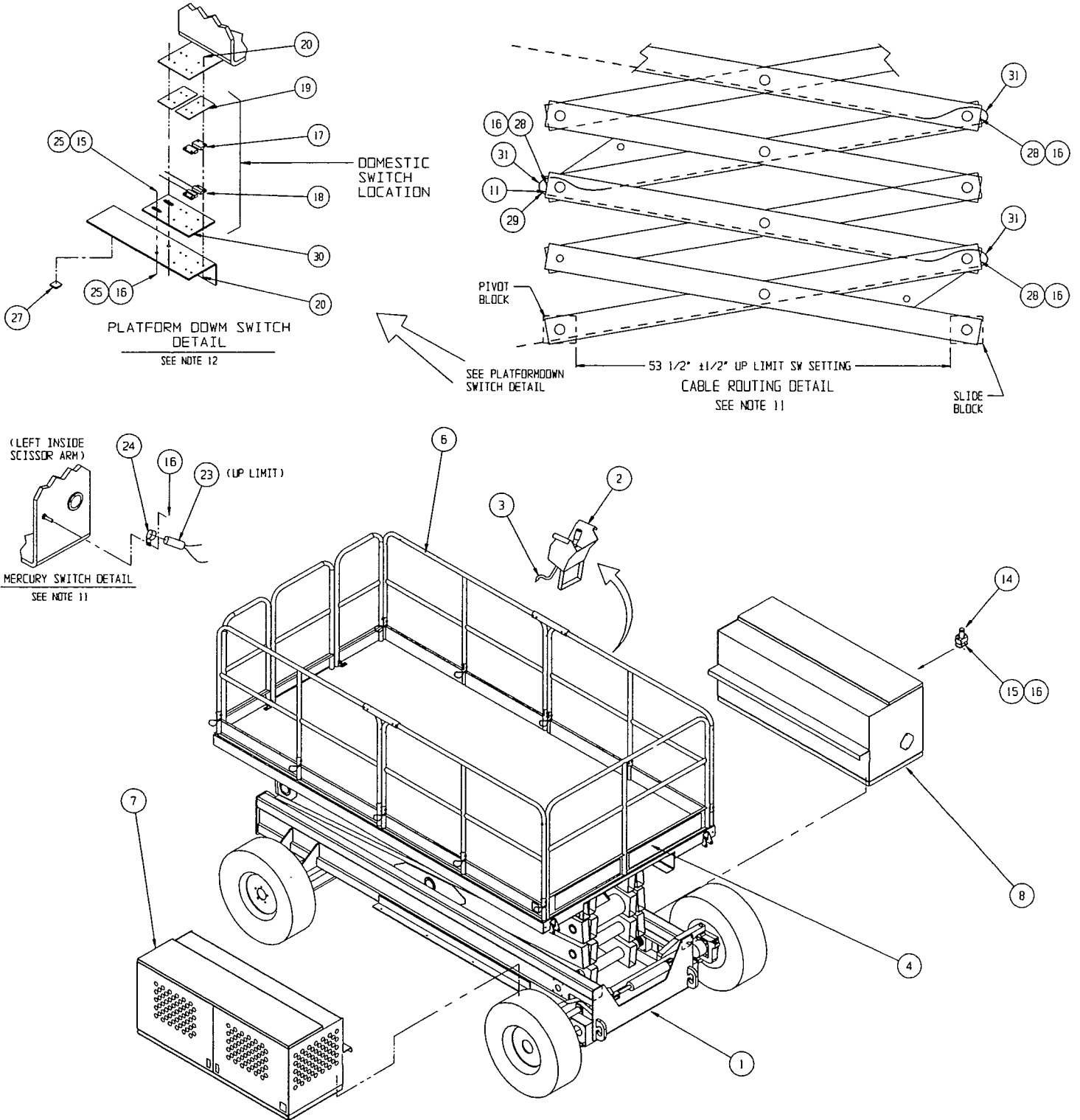

Final Assembly, LX50
Drawing 1 of 3

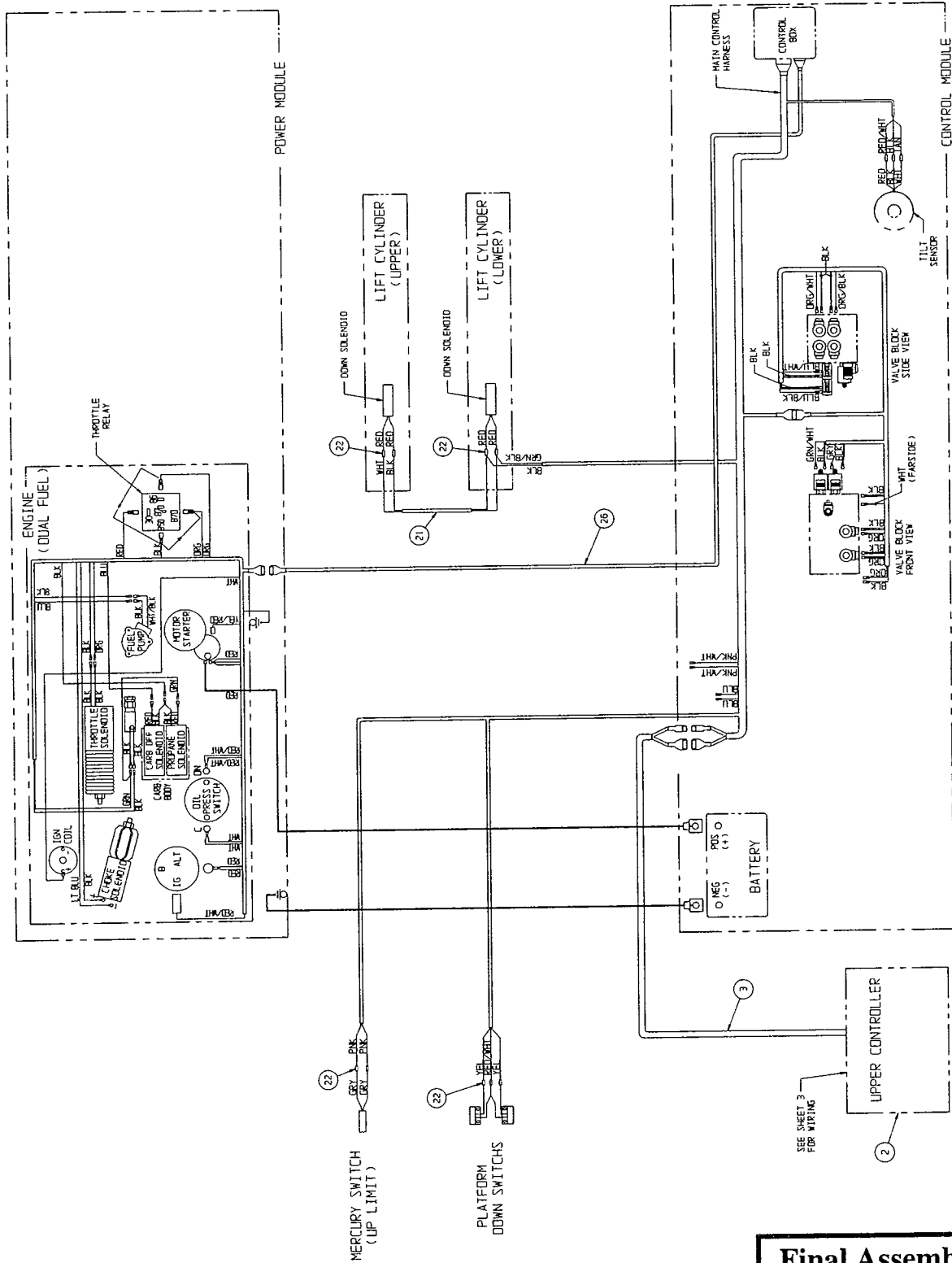

Final Assembly, LX50
Drawing 2 of 3

ILLUSTRATED PARTS BREAKDOWN

Section 6.1

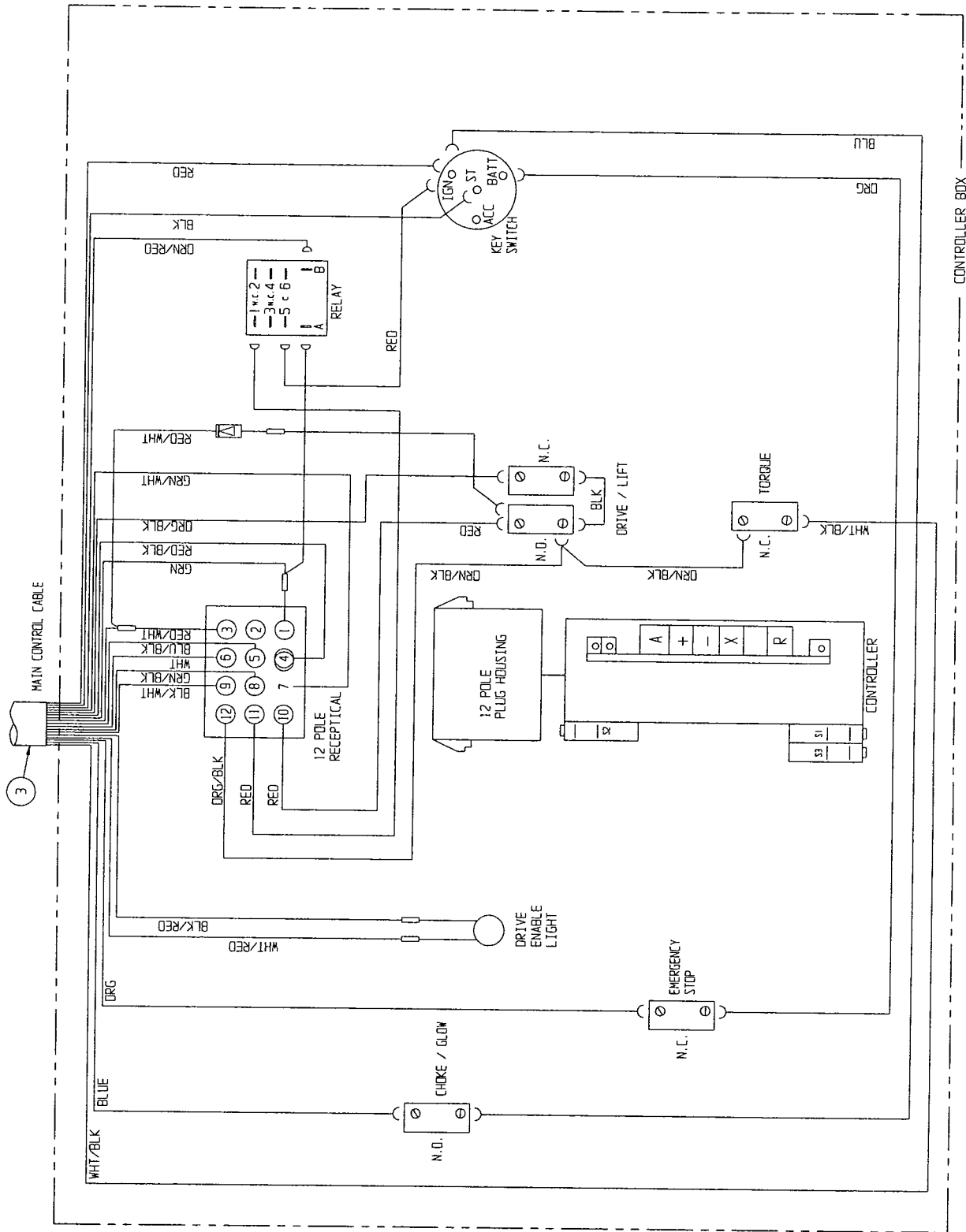

Final Assembly, LX50
Drawing 2 of 3

**Section
6.1**

ILLUSTRATED PARTS BREAKDOWN

**FINAL ASSEMBLY, LX50 TWO-WHEEL DRIVE
DIESEL, STANDARD DECK
067547-010**

ITEM	PART NO.	DESCRIPTION	QTY.
1	067508-001	BASIC ASSY	1
2	067528-010	CONTROLLER ASSEMBLY	1
3	067536-012	CONTROL CABLE ASSEMBLY	1
4	067532-143	LABEL-KIT (DOM)	1
5	067533-022	HOSE-KIT	1
6	067530-005	GUARDRAIL	1
7	067522-012	POWER MODULE ASSEMBLY	1
8	067521-021	CONTROL MODULE ASSEMBLY	1
9	067534-014	HYDRAULIC SCHEMATIC	REF
10	067535-055	ELECTRICAL SCHEMATIC (DOM)	REF
12	029945-013	LEVEL SENSOR	1
13	011252-006	SCRW, 1/4-20 X 3/4	4
14	011248-004	LOCKNUT, 1/4-20 UNC	8
15	065373-005	MAGNET	2
16	065373-006	SWITCH	2

ITEM	PART NO.	DESCRIPTION	QTY.
17	067913-000	ALUM. SW. PAD	1
18	026551-005	RIVET 1/8 X 1/4 GRIP	8
20	029620-002	CONN. BUTT 16-14 GA.	12
21	063497-001	MERCURY SWITCH	1
22	013919-013	CLAMP	1
23	014996-004	WASHER, 1/4 SAE FLAT	4
24	020398-012	CLAMP, CUSHIONED, Ø 1 1/2	4
25	013283-002	CABLE MOUNT	4
26	029490-099	CABLE 2 COND. 16 GA.	30 FT
27	012865-099	WIRE LOOM 3/4 DIA	8
28	067863-000	SWITCH MOUNT	1
31	067492-003	WIRE HARNESS, ENGINE EXTENSION	1
33	067758-099	NYLON HOSE GUARD	8 FT
34	067692-000	CLIP, CABLE RETAINER	4

NOTES:

1. HYDRAULIC PRESSURE SETTING
FORWARD COUNTER BALANCE - 800 PSI
REVERSE COUNTER BALANCE - 800 PSI
DRIVE MOTOR RELIEF - 3000 PSI
STEERING - 1500 PSI
2. ENGINE SPEED
FULL THROTTLE - 3000 ±50 RPM
IDLE SPEED - 1350 ±50 RPM
3. DRIVE SPEED
SLOW - .30-.35 MPH (38-45 SEC. @ 20 FT.)
HIGH - 2.9-3.1 MPH (4.4-4.7 SEC. @ 20 FT.)
4. LIFT SPEED
UP - 80 SECONDS DOWN - 75 SECONDS
5. PROOF LOAD - 1500 LBS.
6. RATED LOAD - 1000 LBS./455 KG.
7. GRADABILITY 24% MIN. (2900 LBS. DRAWBAR PULL)
8. CAUTION:
MAKE SURE THAT PUMP IS FILLED WITH HYDRAULIC OIL PRIOR TO OPERATION, OR SERIOUS DAMAGE WILL OCCUR.
9. CHECK TIRE PRESSURE (10-16.5 NHS 8 PLY) @ 50 PSI
10. SET MERCURY SWITCH (DRIVE CUT-OUT) TO OPEN @ 8 METERS (26'-3") PLATFORM HEIGHT.
11. SET MERCURY SWITCH (UP LIMIT) TO OPEN AT SPECIFIED DIMENSION TO PREVENT FULL EXTENSION OF LIFT CYL.
12. SWITCH TO OPEN LESS THAN 2 FT. PLATFORM LIFT.
13. BLEED AIR OUT OF BRAKES.

ILLUSTRATED PARTS BREAKDOWN

Section 6.1

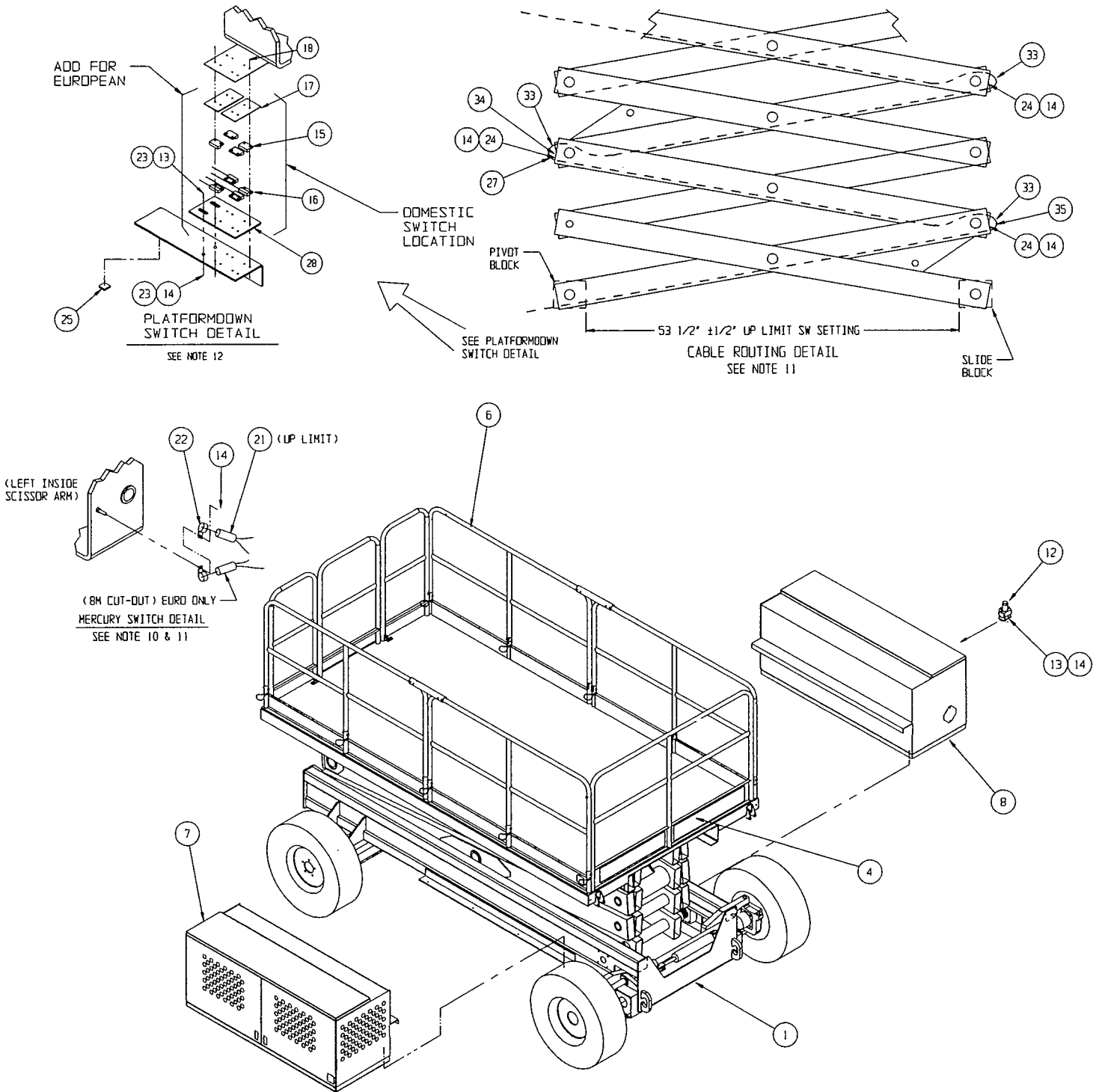

Final Assembly, LX50
Drawing 1 of 3

ILLUSTRATED PARTS BREAKDOWN

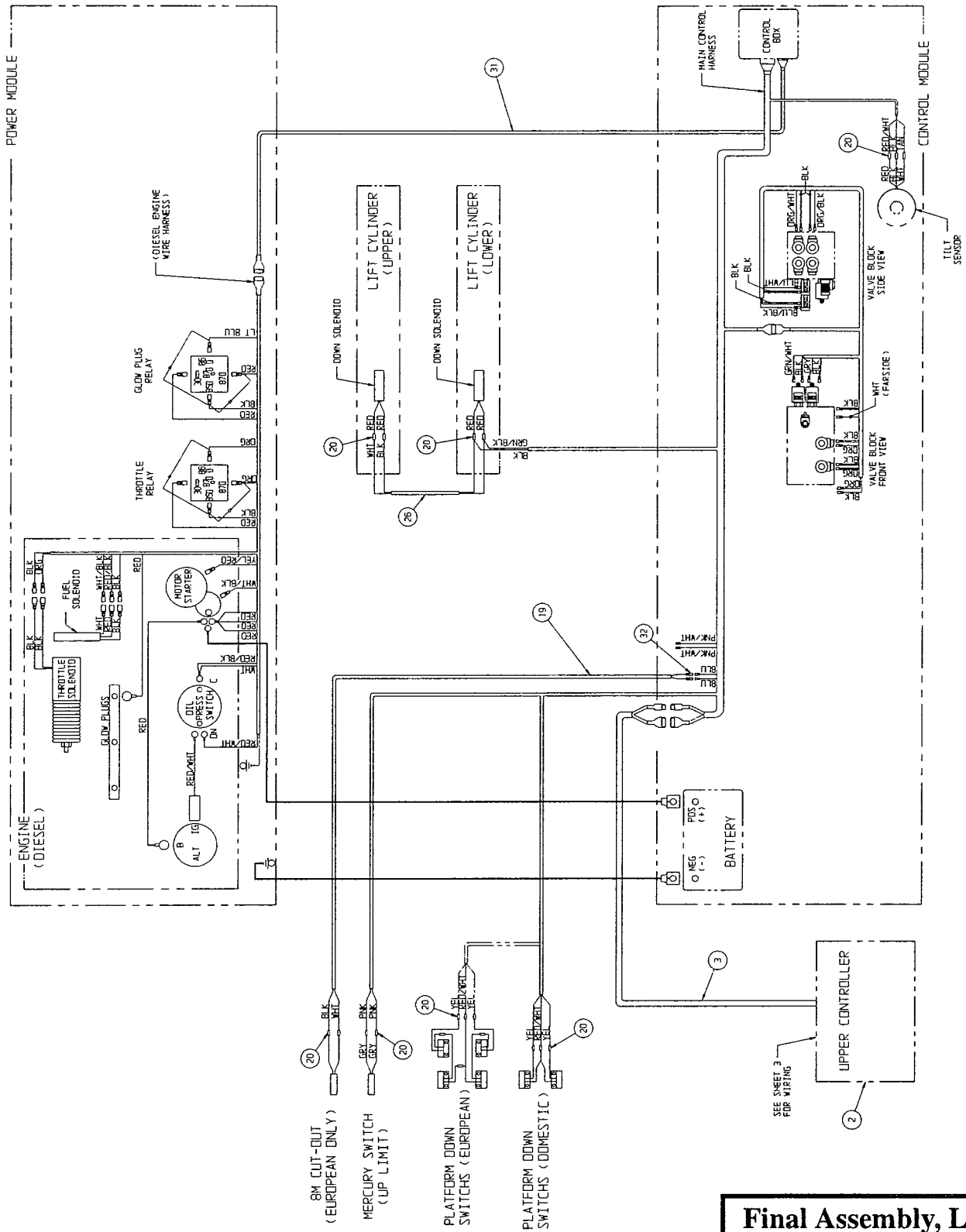

Final Assembly, LX50
Drawing 2 of 3

ILLUSTRATED PARTS BREAKDOWN

Section 6.1

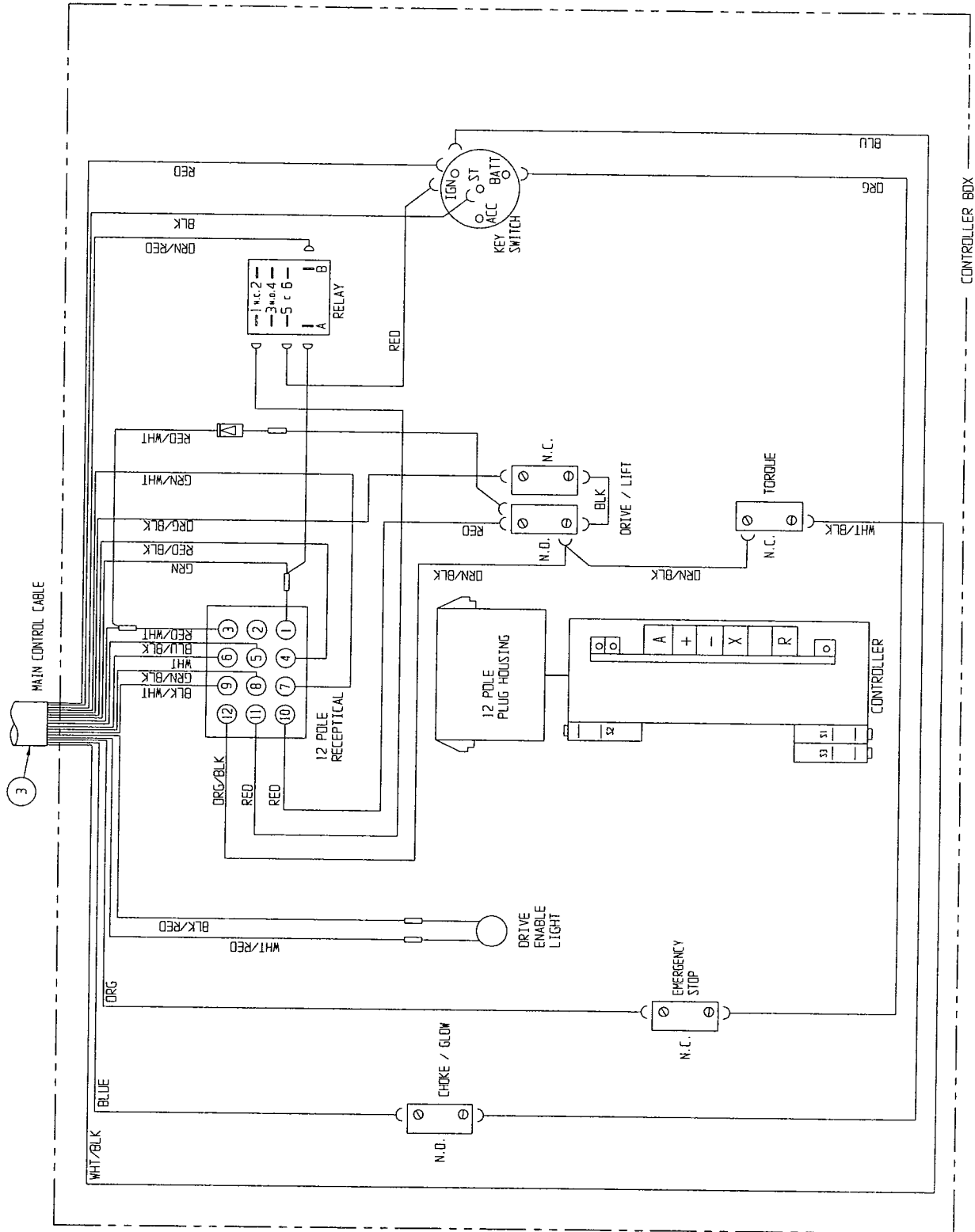

Final Assembly, LX50
Drawing 3 of 3

ILLUSTRATED PARTS BREAKDOWN

**FINAL ASSEMBLY, LX50 FOUR-WHEEL DRIVE
DUAL FUEL, STANDARD DECK
067548-010**

ITEM	PART NO.	DESCRIPTION	QTY.
1	067509-001	BASIC ASSY	1
2	067528-010	CONTROLLER ASSY	1
3	067536-012	CONTROL CABLE ASSY	1
4	067532-144	LABEL-KIT	1
5	067533-023	HOSE-KIT	1
6	067530-005	GUARDRAIL	1
7	067522-011	POWER MODULE ASSEMBLY	1
8	067521-022	CONTROL MODULE ASSEMBLY	1
9	067534-015	HYDRAULIC SCHEMATIC	REF
10	067535-056	ELECTRICAL SCHEMATIC	REF
11	029490-099	CABLE 2 COND. 16 GA.	30 FT
12	067692-000	CLIP, CABLE RETAINER	4
13	029457-099	WIRE 16AWG THHN GREEN	.2 FT
14	029945-013	LEVEL SENSOR	1
15	011252-006	SCRW, 1/4-20 X 3/4	4
16	011248-004	LOCKNUT, 1/4-20 UNC	8
17	065373-005	MAGNET	2

ITEM	PART NO.	DESCRIPTION	QTY.
18	065373-006	SWITCH	2
19	067913-000	ALUM. SW. PAD	1
20	026551-005	RIVET 1/8 X 1/4 GRIP	8
21	029490-099	CABLE 2 COND. 16 GA.	8 FT
22	029620-002	CONN. BUTT 16-14 GA.	12
23	063497-001	MERCURY SWITCH (UP LIMIT)	1
24	013919-013	CLAMP	1
25	014996-004	WASHER, 1/4 SAE FLAT	8
26	067699-000	HOSE CLAMP CHANNEL	2
27	013283-002	CABLE MOUNT	4
28	067758-099	NYLON HOSE GUARD	11.7FT
29	012865-099	WIRE LOOM 3/4 DIA	8 FT
30	067863-000	SWITCH MOUNT	1
33	067492-003	WIRE HARNESS, ENGINE EXTENSION	1
34	014914-001	CONN. MALE PUSH, 16-14 AWG, .25 TAB	2
35	020398-012	CLAMP, CUSHIONED, Ø 1 1/2	4

NOTES:

1. HYDRAULIC PRESSURE SETTING
FORWARD COUNTER BALANCE - 800 PSI
REVERSE COUNTER BALANCE - 800 PSI
DRIVE MOTOR RELIEF - 3000 PSI
STEERING - 1500 PSI
2. ENGINE SPEED
FULL THROTTLE - 3400 ±50 RPM
IDLE SPEED - 1350 ±50 RPM
3. DRIVE SPEED
SLOW - .30-.35 MPH (38-45 SEC. @ 20 FT.)
HIGH - 2.9-3.1 MPH (4.4-4.7 SEC. @ 20 FT.)
4. LIFT SPEED
UP - 80 SECONDS DOWN - 75 SECONDS
5. PROOF LOAD - 1500 LBS.

6. RATED LOAD - 1000 LBS./455 KG.
7. GRADABILITY 24% MIN. (2900 LBS. DRAWBAR PULL)
8. CAUTION:
MAKE SURE THAT PUMP IS FILLED WITH HYDRAULIC OIL PRIOR TO OPERATION, OR SERIOUS DAMAGE WILL OCCUR.
9. CHECK TIRE PRESSURE (10-16.5 NHS 8 PLY) @ 50 PSI
- 10.
11. SET MERCURY SWITCH (UP LIMIT) TO OPEN AT SPECIFIED DIMENSION TO PREVENT FULL EXTENSION OF LIFT CYL.
12. SET SWITCH TO OPEN LESS THAN 2 FT. PLATFORM LIFT.
13. BLEED AIR OUT OF BRAKES.

ILLUSTRATED PARTS BREAKDOWN

Section 6.1

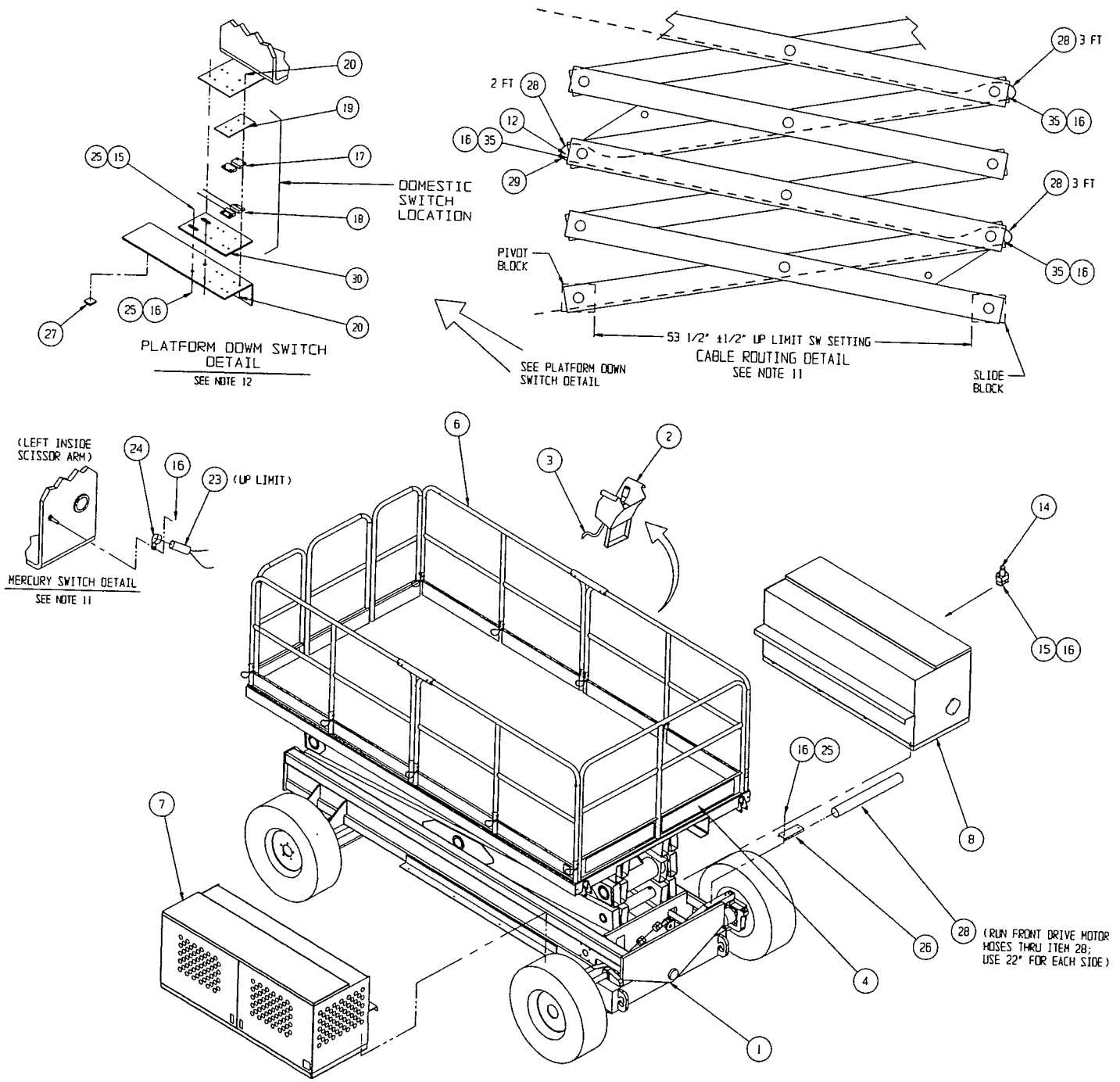

Final Assembly, LX50
Drawing 1 of 3

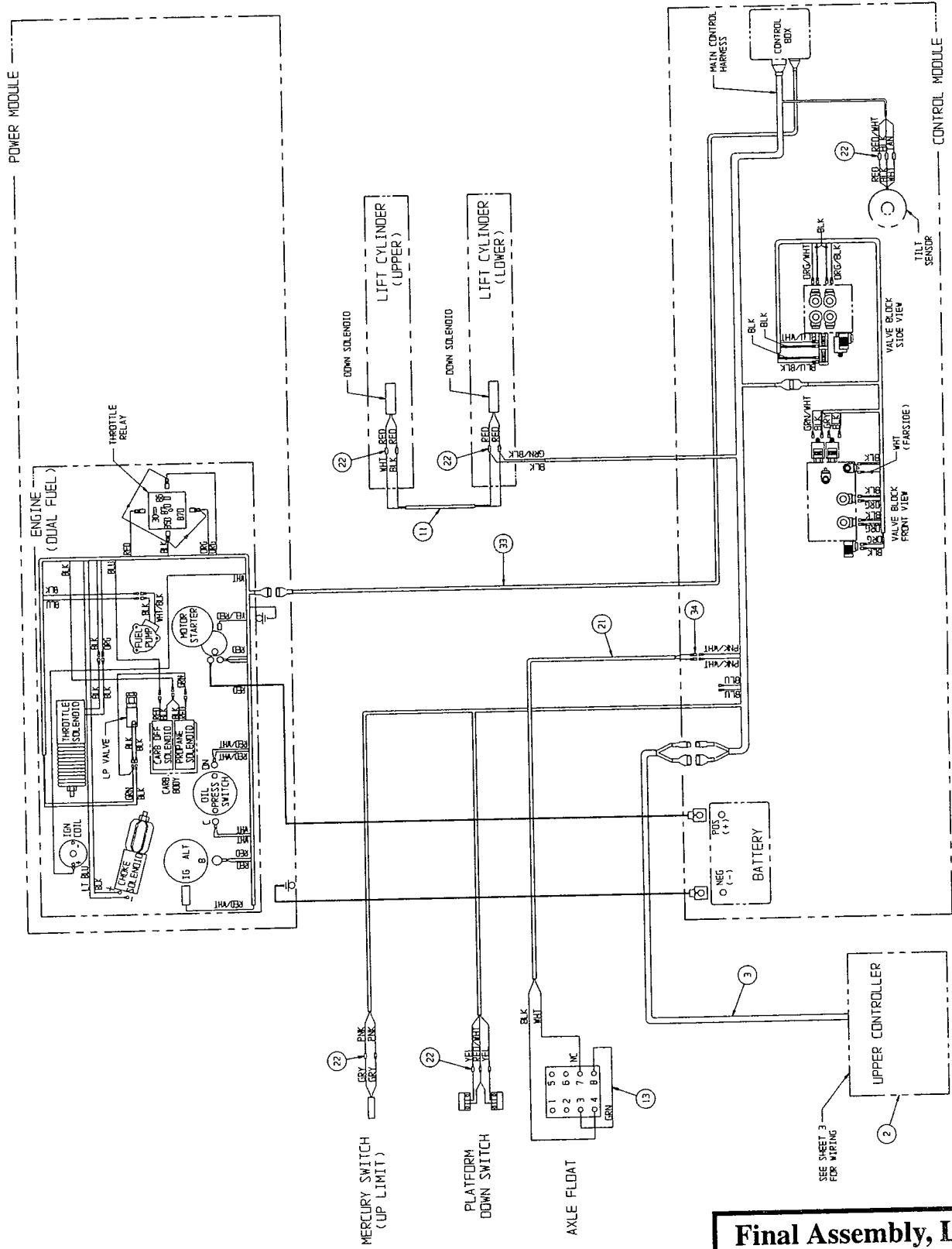

Final Assembly, LX50
Drawing 2 of 3

ILLUSTRATED PARTS BREAKDOWN

Section 6.1

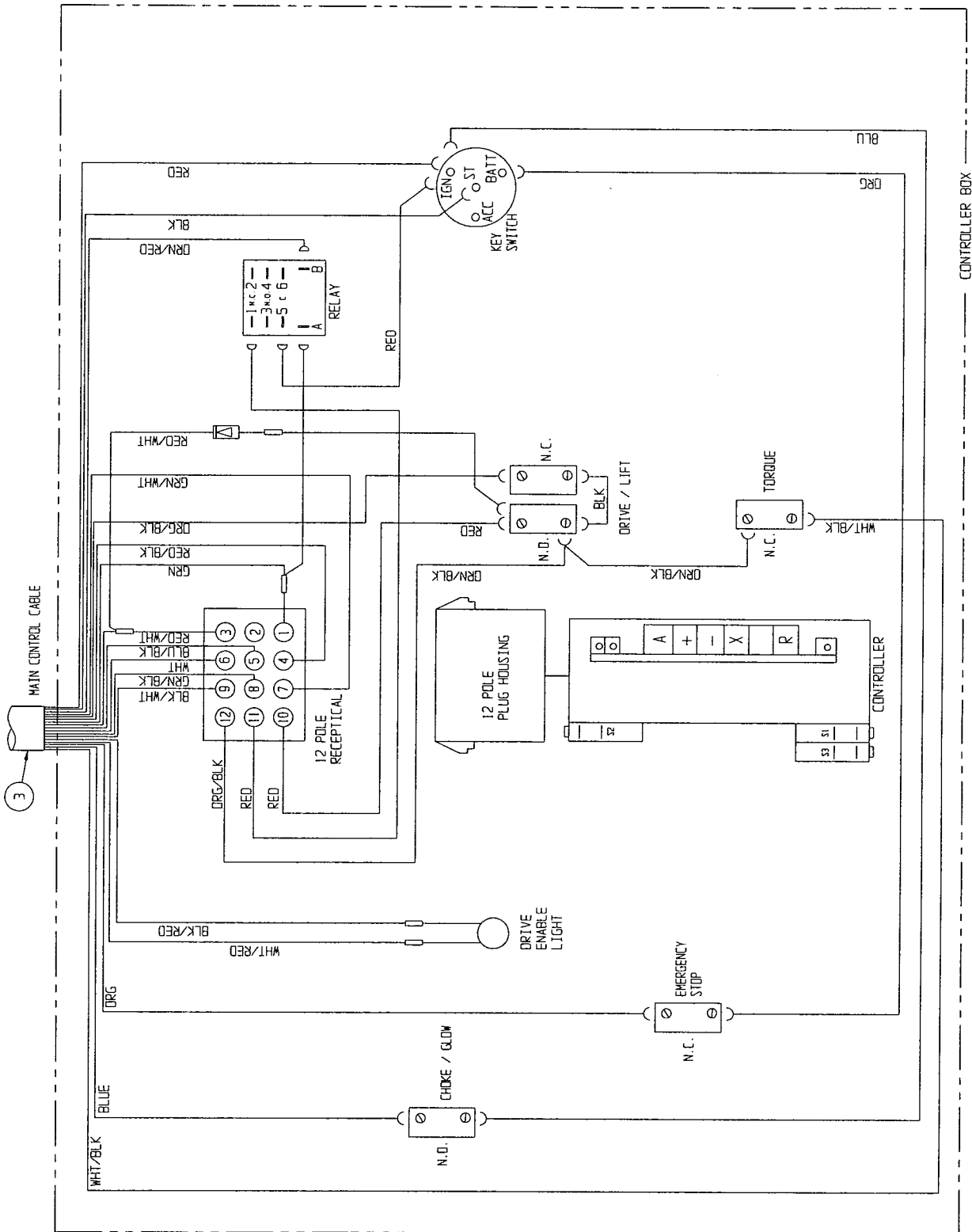

Final Assembly, LX50
Drawing 3 of 3

ILLUSTRATED PARTS BREAKDOWN

FINAL ASSEMBLY, LX50 FOUR-WHEEL DRIVE DIESEL, STANDARD DECK 067549-010

ITEM	PART NO.	DESCRIPTION	QTY.
1	067509-001	BASIC ASSY	1
2	067528-010	CONTROLLER ASSEMBLY	1
3	067536-012	CONTROL CABLE ASSEMBLY	1
4	067532-145	LABEL-KIT (DOM)	1
5	067533-023	HOSE-KIT	1
6	067530-005	GUARDRAIL	1
7	067522-013	POWER MODULE ASSEMBLY	1
8	067521-023	CONTROL MODULE ASSEMBLY	1
9	067534-017	HYDRAULIC SCHEMATIC	REF
10	067535-057	ELECTRICAL SCHEMATIC (DOM)	REF
11	020398-012	CLAMP, CUSHIONED, Ø 1 1/2	4
12	067692-000	CLIP, CABLE RETAINER	4
14	029945-013	LEVEL SENSOR	1
15	011252-006	SCRW, 1/4-20 X 3/4	4
16	011248-004	LOCKNUT, 1/4-20 UNC	8
17	065373-005	MAGNET	2

ITEM	PART NO.	DESCRIPTION	QTY.
18	065373-006	SWITCH	2
19	067913-000	ALUM. SW. PAD	1
20	026551-005	RIVET 1/8 X 1/4 GRIP	8
22	029620-002	CONN. BUTT 16-14 GA.	12
23	063497-001	MERCURY SWITCH	1
24	013919-013	CLAMP	1
25	014996-004	WASHER, 1/4 SAE FLAT	8
26	013283-002	CABLE MOUNT	4
27	014914-001	CONN. MALE PUSH, 16-14 AWG, .25 TAB	2
28	029490-099	CABLE 2 COND. 16 GA.	30 FT
29	012865-099	WIRE LOOM 3/4 DIA	8 FT
30	067863-000	SWITCH MOUNT	1
33	067492-003	WIRE HARNESS, ENGINE EXTENSION	1
34	067758-099	NYLON HOSE GUARD	11.7 FT
35	067699-000	HOSE CLAMP CHANNEL	2
36	029457-099	WIRE, 16 AWG, THHN, GREEN	.2 FT

NOTES:

1. HYDRAULIC PRESSURE SETTING
FORWARD COUNTER BALANCE - 800 PSI
REVERSE COUNTER BALANCE - 800 PSI
DRIVE MOTOR RELIEF - 3000 PSI
STEERING - 1500 PSI
2. ENGINE SPEED
FULL THROTTLE - 3400 ±50 RPM
IDLE SPEED - 1350 ±50 RPM
3. DRIVE SPEED
SLOW - .30-.35 MPH (38-45 SEC. @ 20 FT.)
HIGH - 2.9-3.1 MPH (4.4-4.7 SEC. @ 20 FT.)
4. LIFT SPEED
UP - 80 SECONDS DOWN - 75 SECONDS
5. PROOF LOAD - 1500 LBS.
6. RATED LOAD - 1000 LBS./455 KG.
7. GRADABILITY 24% MIN. (2900 LBS. DRAWBAR PULL)
8. CAUTION:
MAKE SURE THAT PUMP IS FILLED WITH HYDRAULIC OIL PRIOR TO OPERATION, OR SERIOUS DAMAGE WILL OCCUR.
9. CHECK TIRE PRESSURE (10-16.5 NHS 8 PLY) @ 50 PSI
- 10.
11. SET MERCURY SWITCH (UP LIMIT) TO OPEN AT SPECIFIED DIMENSION TO PREVENT FULL EXTENSION OF LIFT CYL.
12. SET SWITCH TO OPEN LESS THAN 2 FT. PLATFORM LIFT.
13. BLEED AIR OUT OF BRAKES.

ILLUSTRATED PARTS BREAKDOWN

Section 6.1

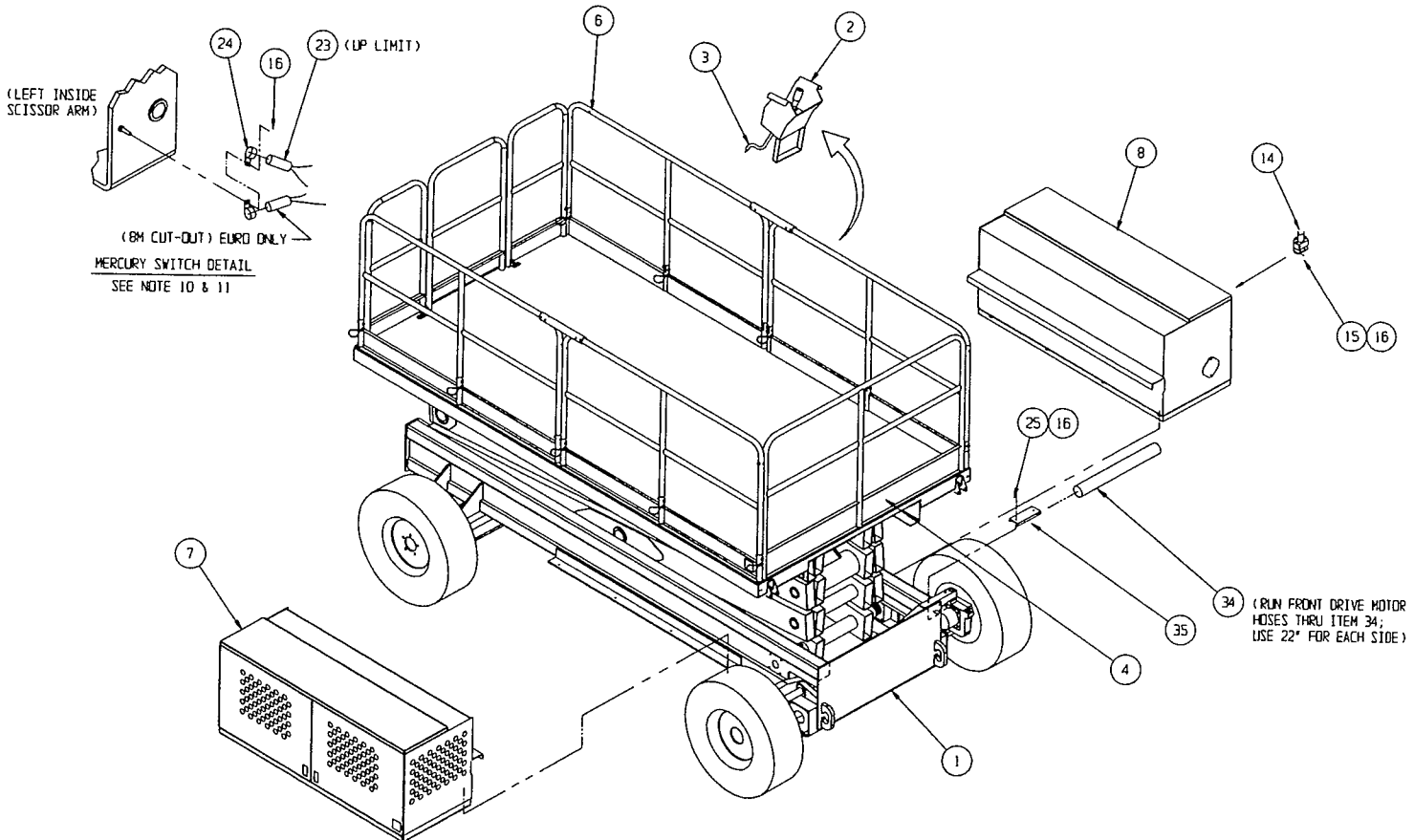
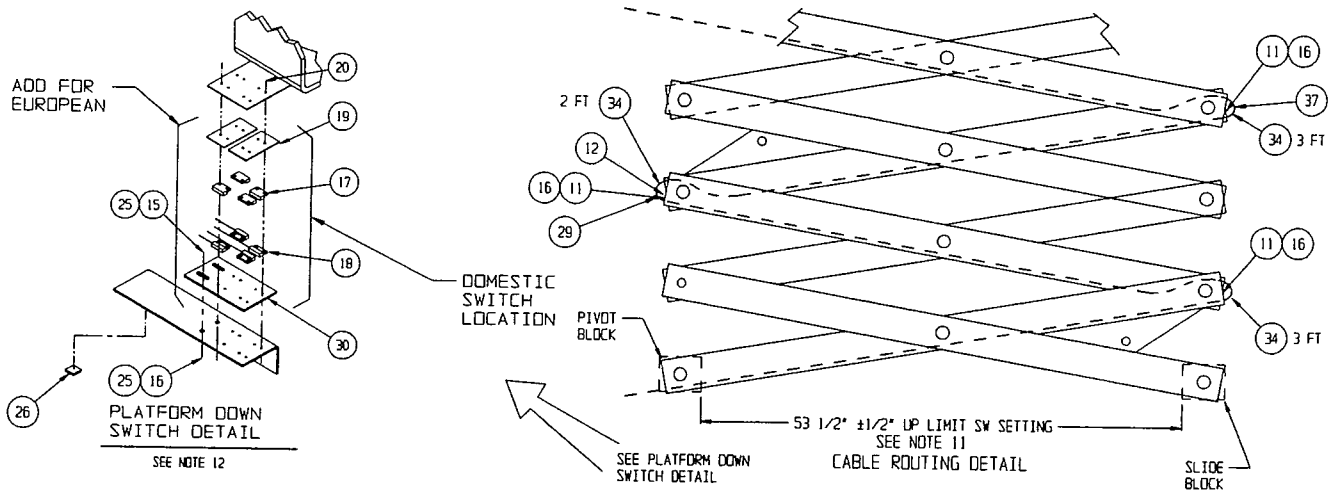

Final Assembly, LX50

Drawing 1 of 3

ILLUSTRATED PARTS BREAKDOWN

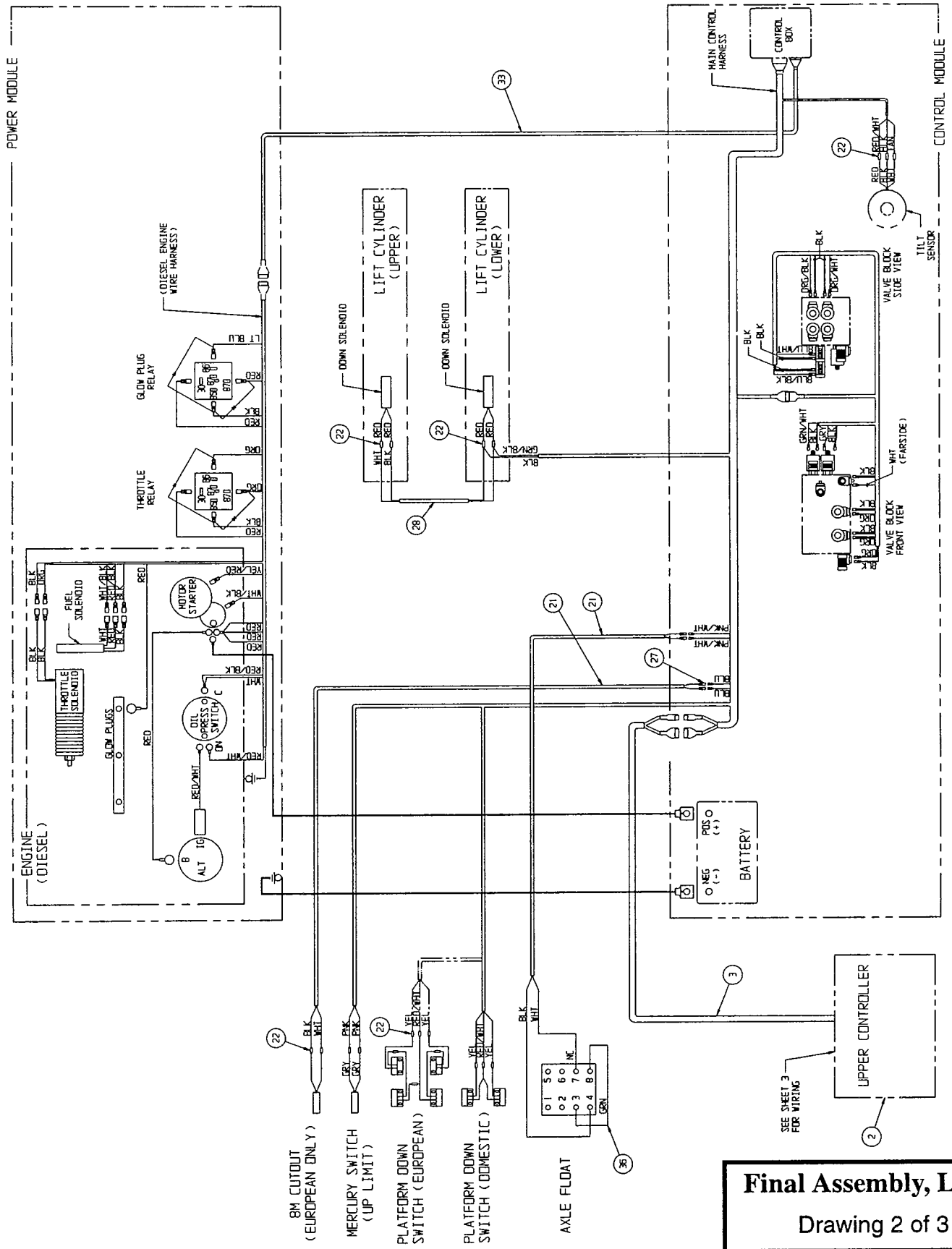

Final Assembly, LX50
Drawing 2 of 3

ILLUSTRATED PARTS BREAKDOWN

Section 6.1

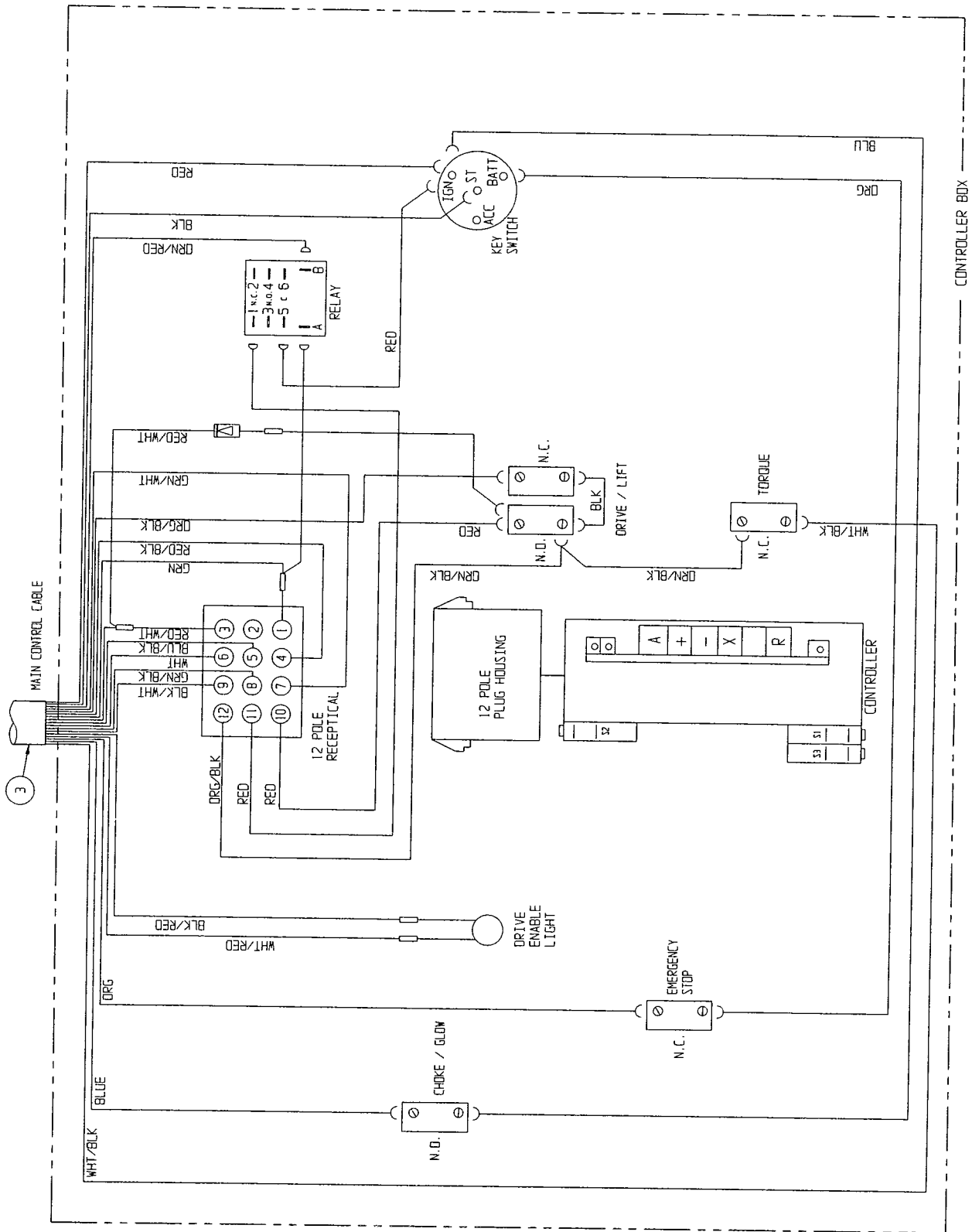

Final Assembly, LX50
Drawing 3 of 3

**FINAL ASSEMBLY, LX50 TWO-WHEEL DRIVE
DUAL FUEL, DUAL DECK
067408-010**

ITEM	PART NO.	DESCRIPTION	QTY.
1	067419-000	BASIC ASSY	1
2	067528-011	CONTROLLER ASSY W/OUTRIGGERS	1
3	067536-012	CONTROL CABLE ASSY	1
4	067532-128	LABEL-KIT	1
5	067533-024	HOSE-KIT	1
6	030841-300	GUARDRAIL	1
7	067522-010	POWER MODULE ASSEMBLY	1
8	067521-028	CONTROL MODULE ASSEMBLY	1
9	067534-016	HYDRAULIC SCHEMATIC	REF
10	067535-058	ELECTRICAL SCHEMATIC	REF
11	067866-001	SLIDE-OUT DECK INSTL	1
12	067692-000	CLIP, CABLE RETAINER	4
13	000942-000	ORBIT LEVEL	1
14	029945-013	LEVEL SENSOR	1
15	011252-006	SCRW, 1/4-20 X 3/4	4
16	011248-004	LOCKNUT, 1/4-20 UNC	13
17	065373-005	MAGNET	2
18	065373-006	SWITCH	2
19	067913-000	ALUM. SW. PAD	1

ITEM	PART NO.	DESCRIPTION	QTY.
20	026551-005	RIVET 1/8 X 1/4 GRIP	8
23	063497-001	MERCURY SWITCH	2
24	013919-013	CLAMP	2
25	014996-004	WASHER, 1/4 SAE FLAT	4
26	067866-002	SLIDE OUT DECK-REAR	1
27	013283-002	CABLE MOUNT	4
28	067482-000	OUTRIGGER INSTALATION	1
29	012865-099	WIRE LOOM 3/4 DIA	8 FT
30	067863-000	SWITCH MOUNT	1
35	064794-000	LEVEL MOUNT	1
36	014924-008	U-BOLT	2
37	011721-008	SCREW, RND HD, MACH. 4-40 X 1	3
38	005133-000	SPRING	3
40	011248-049	NUT, HEX, 4-40 ESNA	3
41	020398-012	CLAMP, CUSHIONED, Ø 1 1/2	5
42	067758-099	NYLON HOSE GUARD	8 FT
43	068132-001	RELAY - 12 VDC	2
44	011826-006	SCREW - #10-32 x 3/4	2
45	011249-003	NUT - #10-32 HEX	2

NOTES:

1. HYDRAULIC PRESSURE SETTING
FORWARD COUNTER BALANCE - 500 PSI
REVERSE COUNTER BALANCE - 500 PSI
DRIVE MOTOR RELIEF - 3000 PSI
STEERING - 1500 PSI
2. ENGINE SPEED
FULL THROTTLE - 3400 ±50 RPM
IDLE SPEED - 1350 ±50 RPM
3. DRIVE SPEED
SLOW - .30-.35 MPH (38-45 SEC. @ 20 FT.)
HIGH - 2.9-3.1 MPH (4.4-4.7 SEC. @ 20 FT.)
4. LIFT SPEED
UP - 90 SECONDS DOWN - 120 SECONDS
5. PROOF LOAD - 1125 LBS.
6. RATED LOAD - 750 LBS./340 KG.
7. GRADABILITY 24% MIN. (2900 LBS. DRAWBAR PULL)
8. CAUTION:
MAKE SURE THAT PUMP IS FILLED WITH HYDRAULIC OIL PRIOR TO OPERATION, OR SERIOUS DAMAGE WILL OCCUR.
9. CHECK THAT POLYFILL TIRES ARE USED.
10. SET MERCURY SWITCH (DRIVE CUT-OUT) TO OPEN @ 40 FT. PLATFORM HEIGHT.
11. SET MERCURY SWITCH (UP LIMIT) TO OPEN AT SPECIFIED DIMENSION TO PREVENT FULL EXTENSION OF LIFT CYL.
12. SET SWITCH TO OPEN LESS THAN 2 FT. PLATFORM LIFT.
13. BLEED AIR OUT OF BRAKES.

ILLUSTRATED PARTS BREAKDOWN

Section 6.1

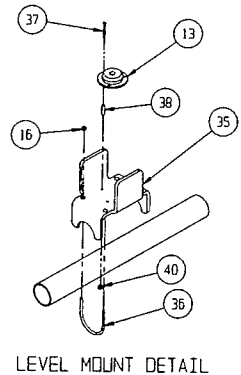
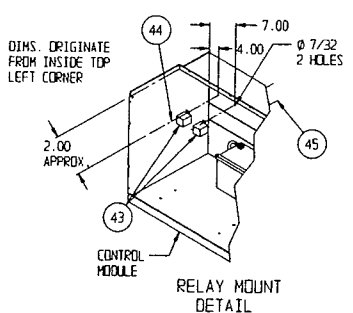
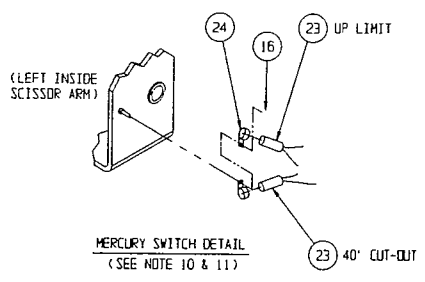
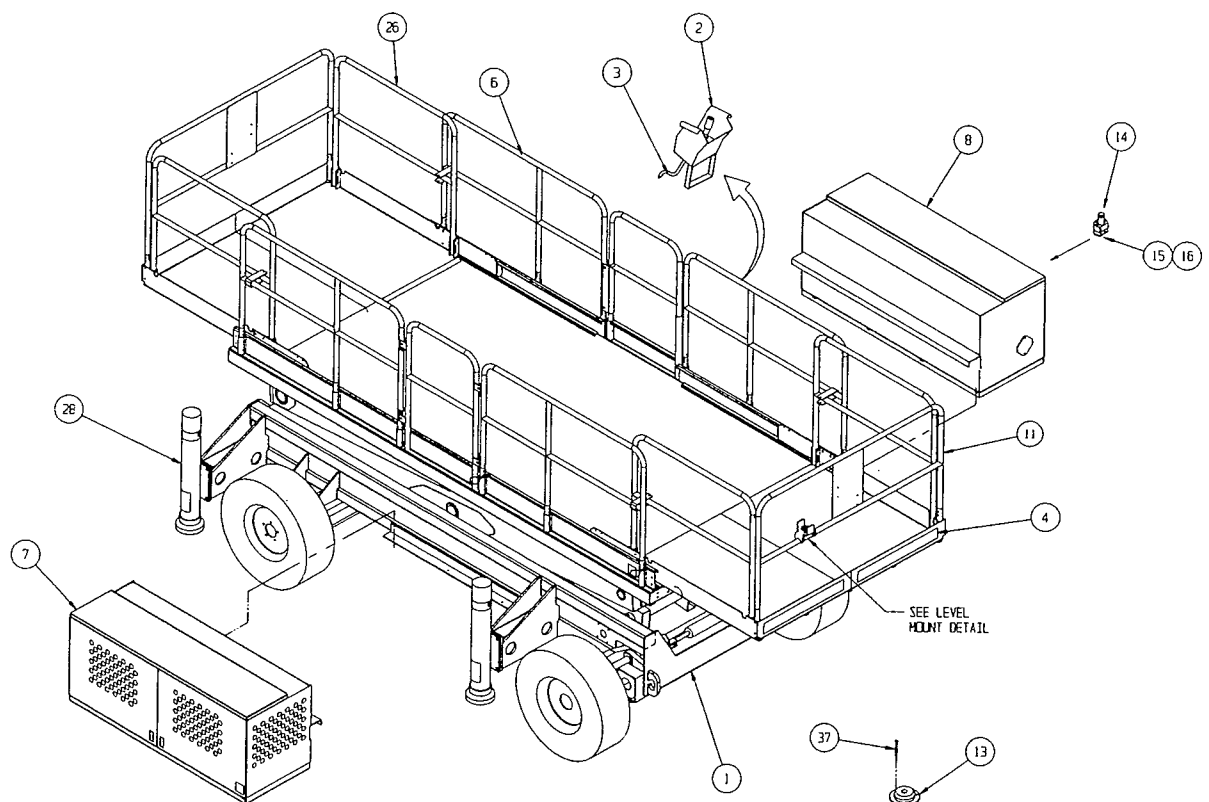
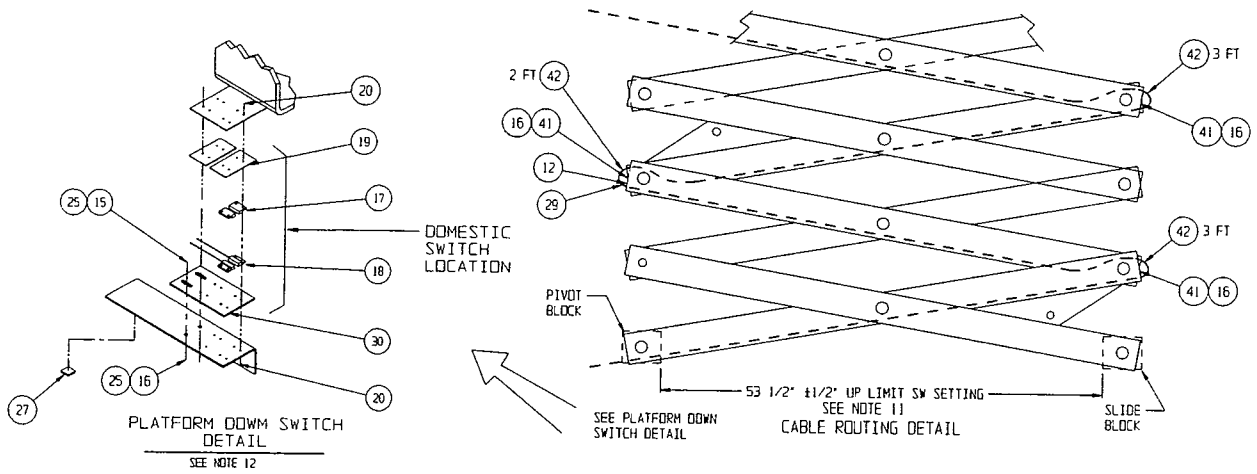

Final Assembly, LX50
Drawing 1 of 3

ILLUSTRATED PARTS BREAKDOWN

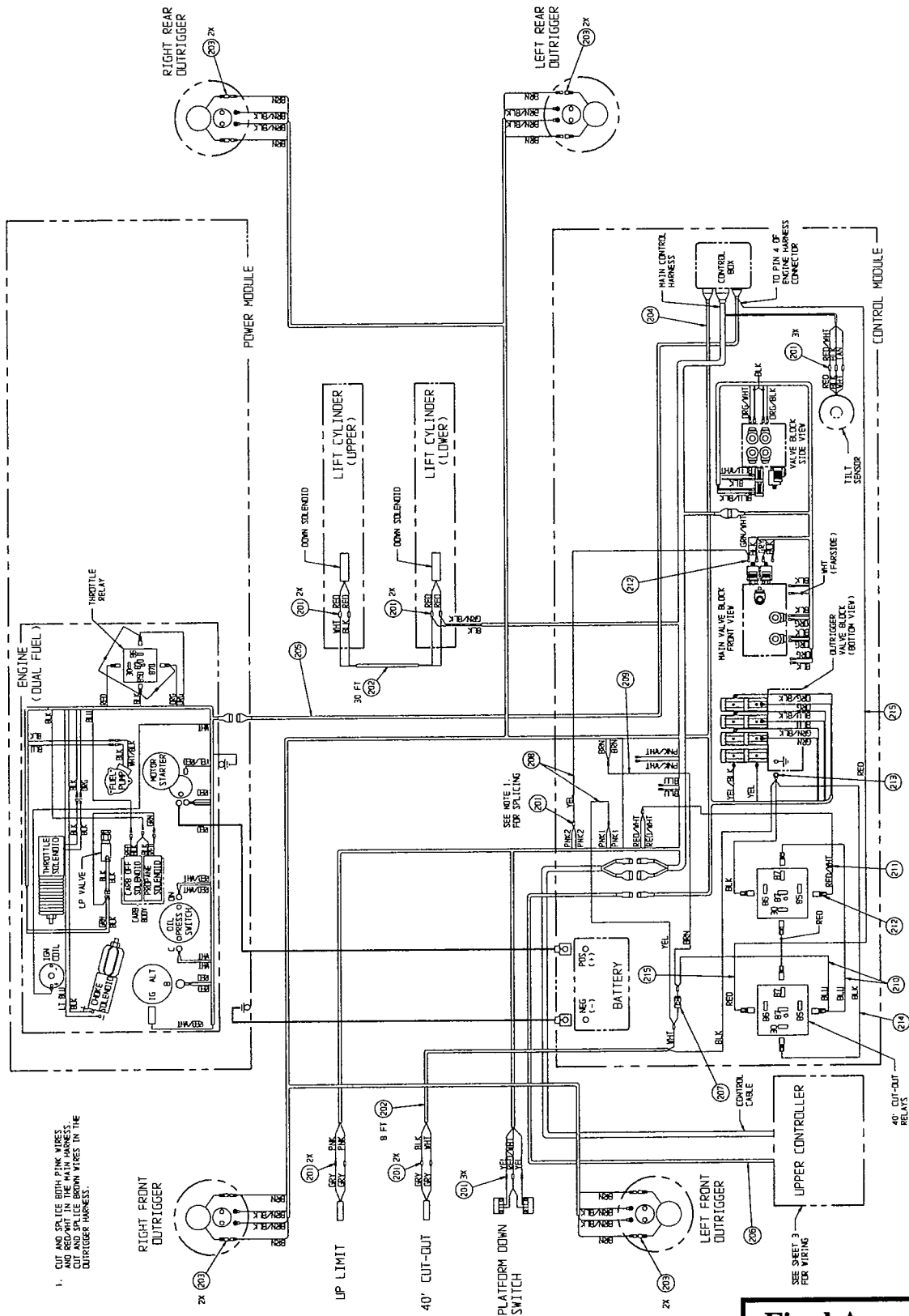

Final Assembly, LX50
Drawing 2 of 3

ILLUSTRATED PARTS BREAKDOWN

Section 6.1

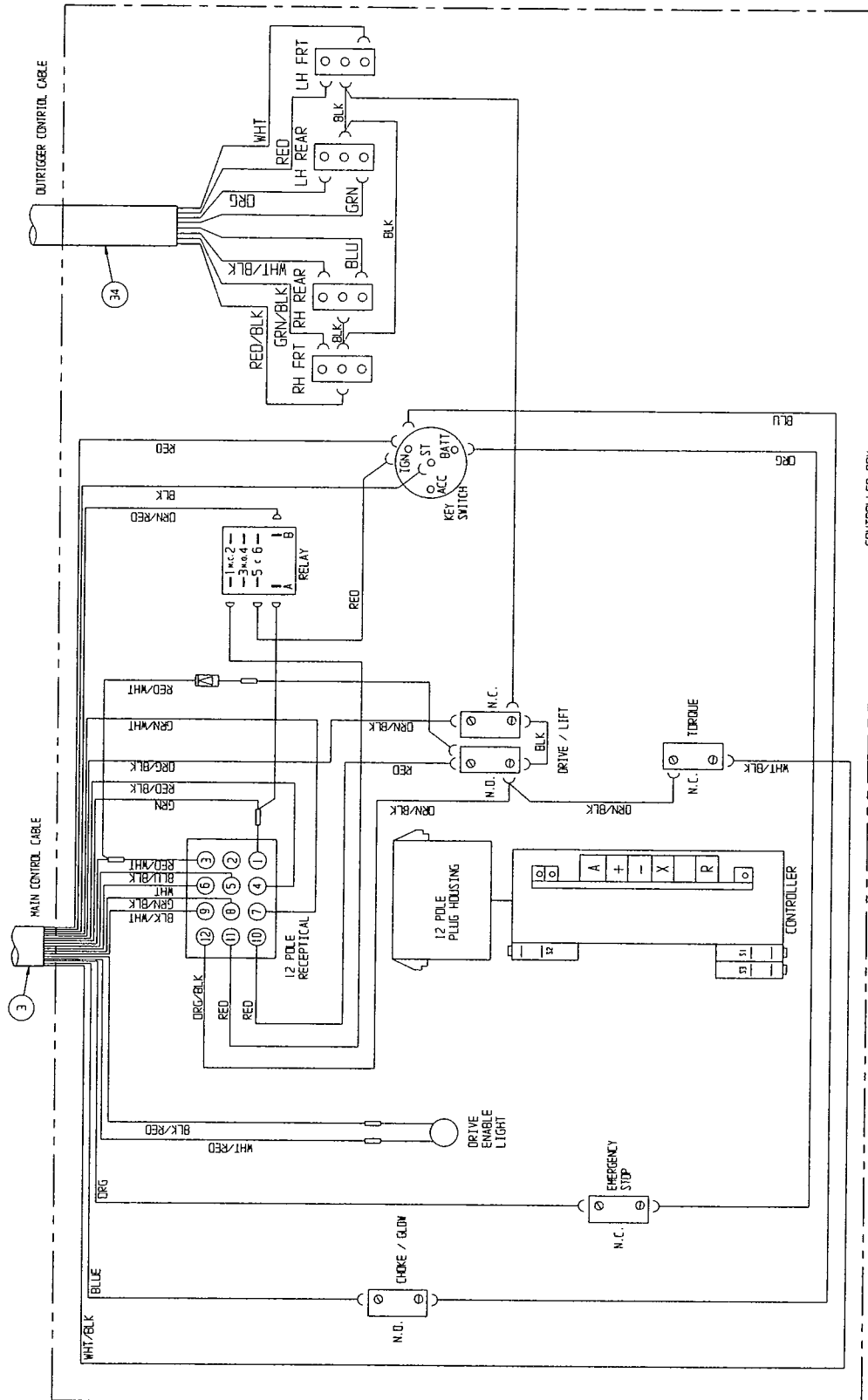

Final Assembly, LX50
Drawing 3 of 3

ILLUSTRATED PARTS BREAKDOWN

**FINAL ASSEMBLY, LX50 Two-WHEEL DRIVE
DIESEL, DUAL DECK
067409-010**

ITEM	PART NO.	DESCRIPTION	QTY.
1	067419-000	BASIC ASSY	1
2	067528-011	CONTROLLER ASSEMBLY W/OUTRIGGERS (DOM)	1
3	067536-012	CONTROL CABLE ASSEMBLY	1
4	067532-129	LABEL-KIT (DOM)	1
5	067533-024	HOSE-KIT	1
6	030841-300	GUARDRAIL	1
7	067522-012	POWER MODULE ASSEMBLY	1
8	067521-029	CONTROL MODULE ASSEMBLY (DOM)	1
9	067534-016	HYDRAULIC SCHEMATIC (DOM)	REF
10	067535-059	ELECTRICAL SCHEMATIC (DOM)	REF
12	029945-013	LEVEL SENSOR	1
13	011252-006	SCRW, 1/4-20 X 3/4	4
14	011248-004	LOCKNUT, 1/4-20 UNC	13
15	065373-005	MAGNET	2
16	065373-006	SWITCH	2
17	067913-000	ALUM. SW. PAD	1
18	026551-005	RIVET 1/8 X 1/4 GRIP	8
21	063497-001	MERCURY SWITCH	2
22	013919-013	CLAMP	2

ITEM	PART NO.	DESCRIPTION	QTY.
23	014996-004	WASHER, 1/4 SAE FLAT	4
24	067866-002	SLIDE OUT DECK -REAR	1
25	013283-002	CABLE MOUNT	4
27	012865-099	WIRE LOOM 3/4 DIA	8
28	067863-000	SWITCH MOUNT	1
29	000942-000	ORBIT LEVEL	1
30	064794-000	LEVEL MOUNT	1
33	067866-001	SLIDE-OUT DECK INSTL	1
34	067692-000	CLIP, CABLE RETAINER	4
35	067482-000	OUTRIGGER INSTALLATION	1
37	067758-099	NYLON HOSE GUARD	9 FT
38	020398-012	CLAMP, CUSHIONED, Ø 1 1/2	5
39	014924-008	U-BOLT	2
40	011721-008	SCREW, RND HD, MACH., 4-40 X 1	3
41	005133-000	SPRING	3
43	011248-049	NUT, HEX, 4-40 ESNA	3
45	068132-001	RELAY - 12 VDC	2
46	011826-006	SCREW - #10-32 x 3/4	2
47	011249-003	NUT - #10-32 HEX	2

NOTES:

1. HYDRAULIC PRESSURE SETTING
FORWARD COUNTER BALANCE - 500 PSI
REVERSE COUNTER BALANCE - 500 PSI
DRIVE MOTOR RELIEF - 3000 PSI
STEERING - 1500 PSI
2. ENGINE SPEED
FULL THROTTLE - 3000 ±50 RPM
IDLE SPEED - 1350 ±50 RPM
3. DRIVE SPEED
SLOW - .30-.35 MPH (38-45 SEC. @ 20 FT.)
HIGH - 2.9-3.1 MPH (4.4-4.7 SEC. @ 20 FT.)
4. LIFT SPEED
UP - 90 SECONDS DOWN - 120 SECONDS
5. PROOF LOAD - 1125 LBS.
6. RATED LOAD - 750 LBS./340 KG.
7. GRADABILITY 24% MIN. (2900 LBS. DRAWBAR PULL)
8. CAUTION:
MAKE SURE THAT PUMP IS FILLED WITH HYDRAULIC OIL PRIOR TO OPERATION, OR SERIOUS DAMAGE WILL OCCUR.
9. CHECK THAT POLYFILL TIRES ARE USED.
10. SET MERCURY SWITCH (DRIVE CUT-OUT) TO OPEN @ 8 METERS (26'-3") FOR EURD AND 40 FT. FOR DOM.
11. SET MERCURY SWITCH (UP LIMIT) TO OPEN AT SPECIFIED DIMENSION TO PREVENT FULL EXTENSION OF LIFT CYL.
12. SWITCH TO OPEN LESS THAN 2 FT. PLATFORM LIFT.
13. BLEED AIR OUT OF BRAKES.

ILLUSTRATED PARTS BREAKDOWN

Section 6.1

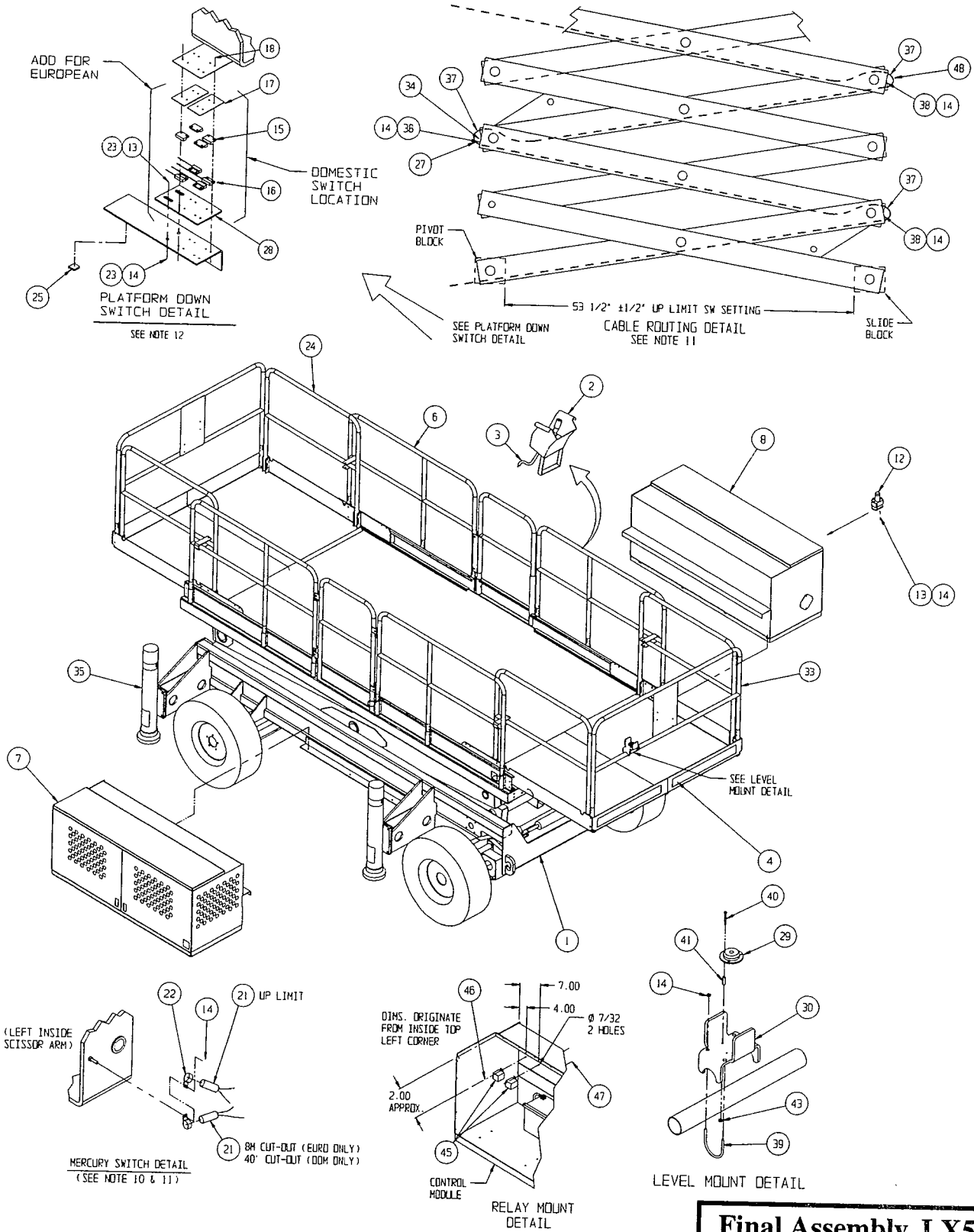

Final Assembly, LX50

Drawing 1 of 3

ILLUSTRATED PARTS BREAKDOWN

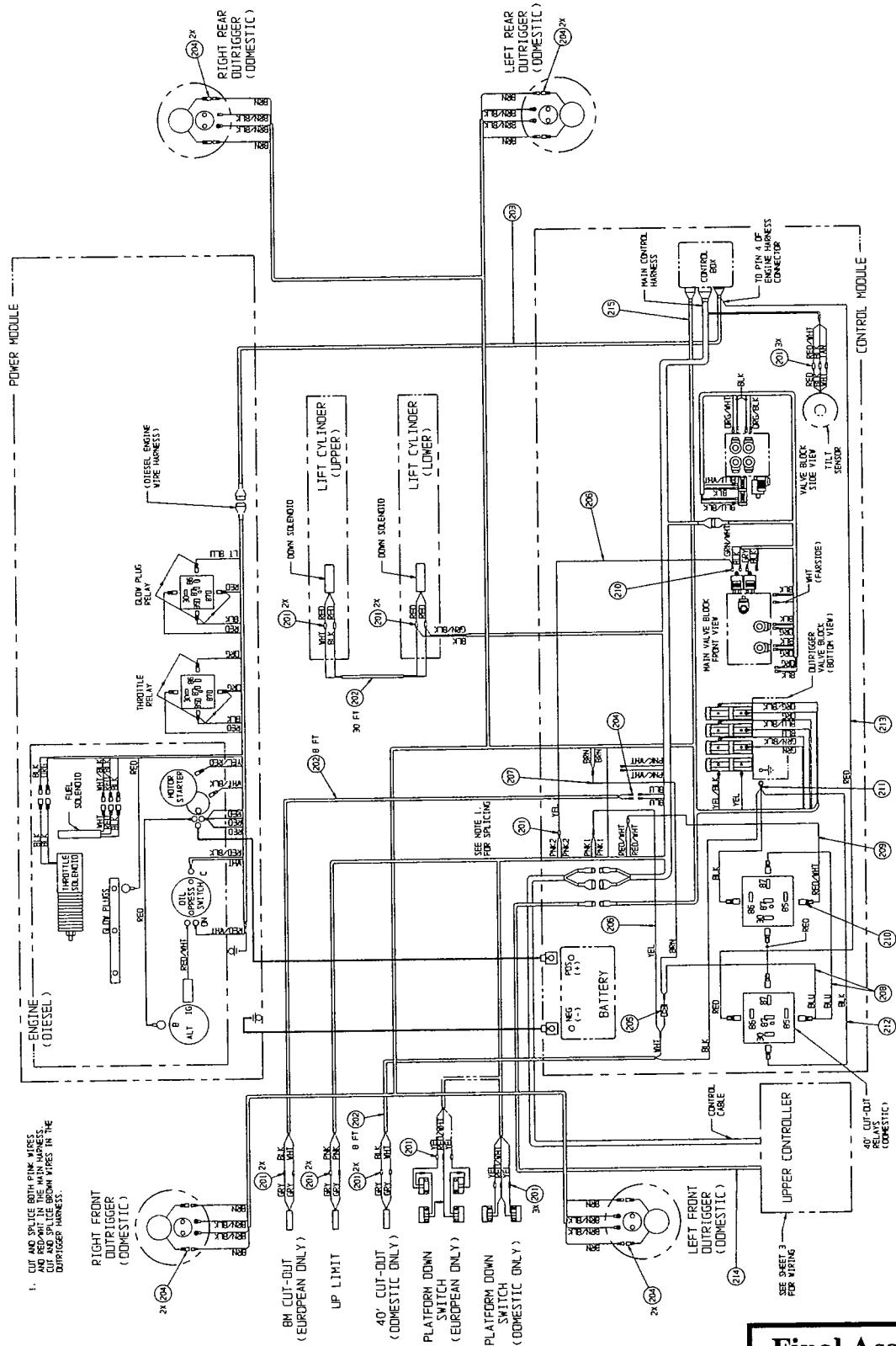

Final Assembly, LX50
Drawing 1 of 3

ILLUSTRATED PARTS BREAKDOWN

Section 6.1

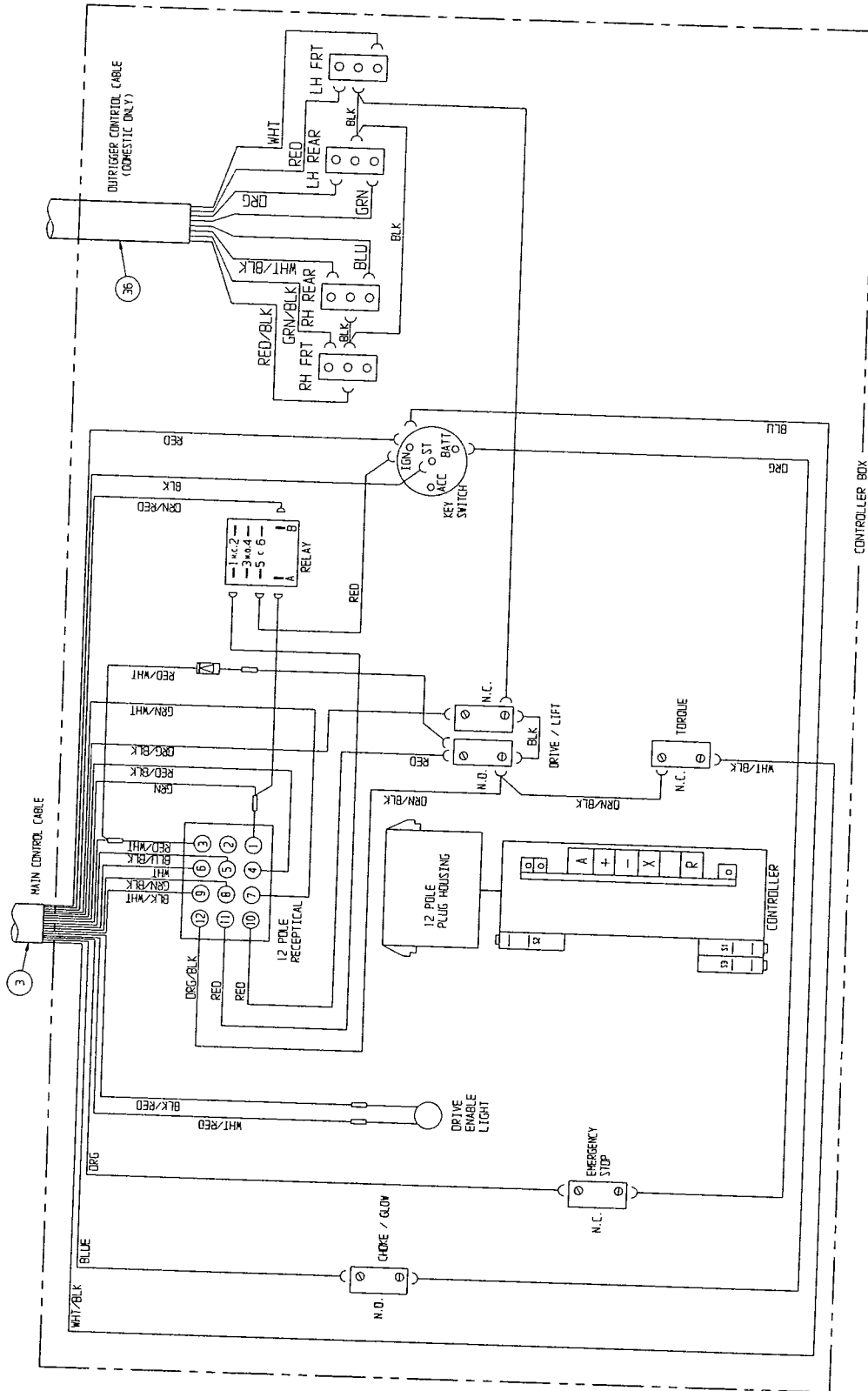

Final Assembly, LX50
Drawing 1 of 3

**Section
6.1**

ILLUSTRATED PARTS BREAKDOWN

FINAL ASSEMBLY, LX50 FOUR-WHEEL DRIVE DUAL FUEL, DUAL DECK 067410-010

ITEM	PART NO.	DESCRIPTION	QTY.
1	067420-000	BASIC ASSY	1
2	067528-011	CONTROLLER ASSY W/OUTRIGGERS	1
3	067536-012	CONTROL CABLE ASSY	1
4	067532-130	LABEL-KIT	1
5	067533-025	HOSE-KIT	1
6	030841-300	GUARDRAIL	1
7	067522-011	POWER MODULE ASSEMBLY	1
8	067521-030	CONTROL MODULE ASSEMBLY	1
9	067534-017	HYDRAULIC SCHEMATIC	REF
10	067535-060	ELECTRICAL SCHEMATIC	REF
11	067866-001	SLIDE-OUT DECK INSTL	1
12	067692-000	CLIP, CABLE RETAINER	4
14	029945-013	LEVEL SENSOR	1
15	011252-006	SCRW, 1/4-20 X 3/4	4
16	011248-004	LOCKNUT, 1/4-20 UNC	13
17	065373-005	MAGNET	2
18	065373-006	SWITCH	2
19	067913-000	ALUM. SW. PAD	1
20	026551-005	RIVET 1/8 X 1/4 GRIP	8
23	063497-001	MERCURY SWITCH	2

ITEM	PART NO.	DESCRIPTION	QTY.
24	013919-013	CLAMP	2
25	014996-004	WASHER, 1/4 SAE FLAT	8
26	067699-000	HOSE CLAMP CHANNEL	2
27	013283-002	CABLE MOUNT	4
28	067758-099	NYLON HOSE GUARD	11.67 FT
29	012865-099	WIRE LOOM 3/4 DIA	8 FT
30	067863-000	SWITCH MOUNT	1
31	000942-00	ORBIT LEVEL	1
32	064794-000	LEVEL MOUNT	1
35	067866-002	SLIDE OUT DECK - REAR	1
36	067482-000	OUTRIGGER INSTALLATION	1
39	014924-008	U-BOLT	2
40	011721-008	SCREW, RND HD, MACH., 4-40 X 1	3
41	005133-000	SPRING	3
43	011248-049	NUT, HEX, 4-40 ESNA	3
44	020398-012	CLAMP, CUSHIONED, Ø 1 1/2	5
46	068132-001	RELAY - 12 VDC	2
47	011826-006	SCREW - #10-32 x 3/4	2
48	011249-003	NUT - #10-32 HEX	2

NOTES:

1. HYDRAULIC PRESSURE SETTING
FORWARD COUNTER BALANCE - 500 PSI
REVERSE COUNTER BALANCE - 500 PSI
DRIVE MOTOR RELIEF - 3000 PSI
STEERING - 1500 PSI
2. ENGINE SPEED
FULL THROTTLE - 3400 ±50 RPM
IDLE SPEED - 1350 ±50 RPM
3. DRIVE SPEED
SLOW - .30-.35 MPH (38-45 SEC. @ 20 FT.)
HIGH - 2.9-3.1 MPH (4.4-4.7 SEC. @ 20 FT.)
4. LIFT SPEED
UP - 90 SECONDS DOWN - 120 SECONDS
5. PROOF LOAD - 1125 LBS.
6. RATED LOAD - 750 LBS./340 KG.

7. GRADABILITY 24% MIN. (2900 LBS. DRAWBAR PULL)
8. CAUTION:
MAKE SURE THAT PUMP IS FILLED WITH HYDRAULIC OIL PRIOR TO OPERATION, OR SERIOUS DAMAGE WILL OCCUR.
9. CHECK THAT POLYFILL TIRES ARE USED.
10. SET MERCURY SWITCH (DRIVE CUT-OUT) TO OPEN AT 40 FT. PLATFORM HEIGHT.
11. SET MERCURY SWITCH (UP LIMIT) TO OPEN AT SPECIFIED DIMENSION TO PREVENT FULL EXTENSION OF LIFT CYL.
12. SET SWITCH TO OPEN LESS THAN 2 FT. PLATFORM LIFT.
13. BLEED AIR OUT OF BRAKES.

ILLUSTRATED PARTS BREAKDOWN

Section 6.1

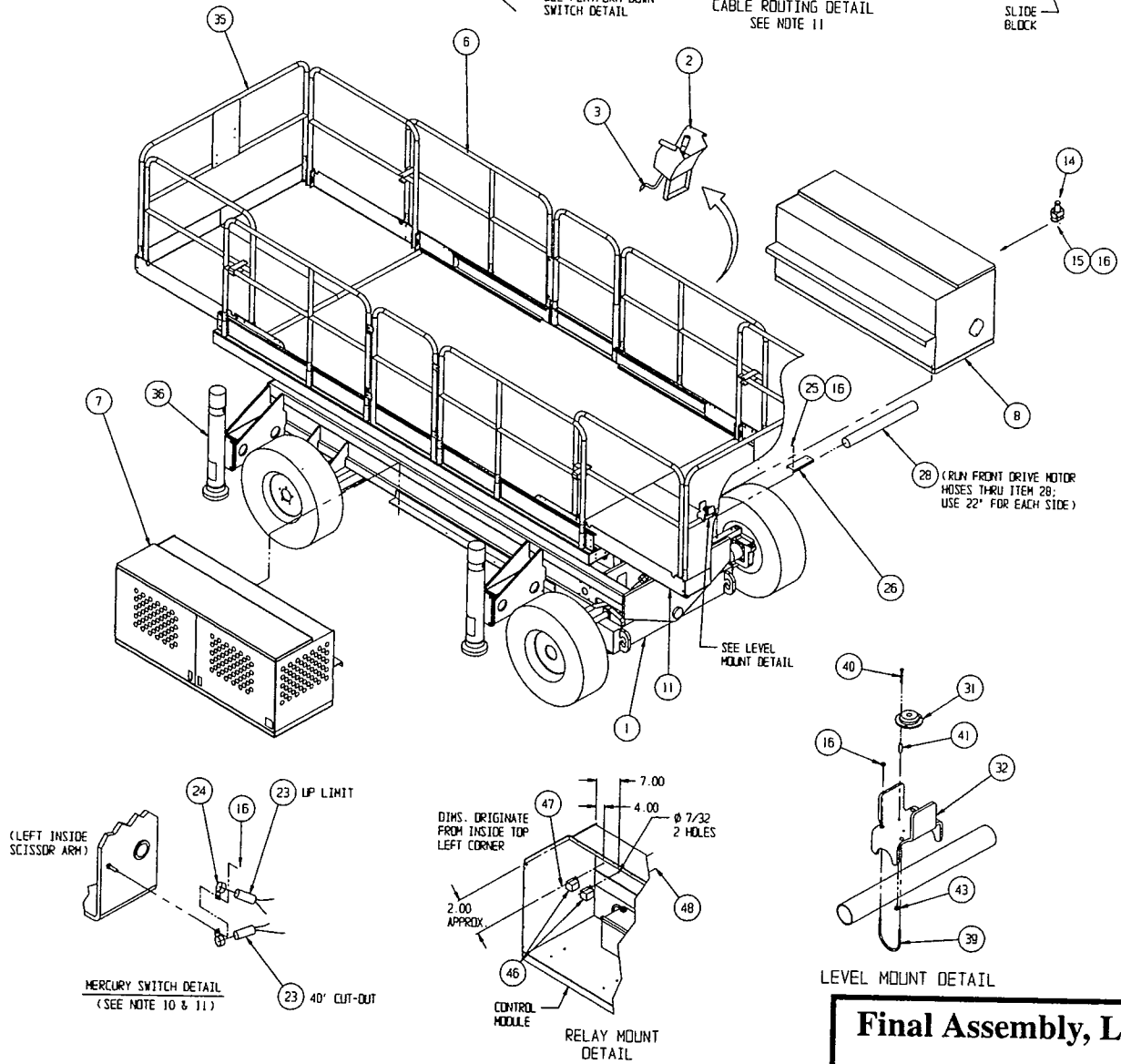
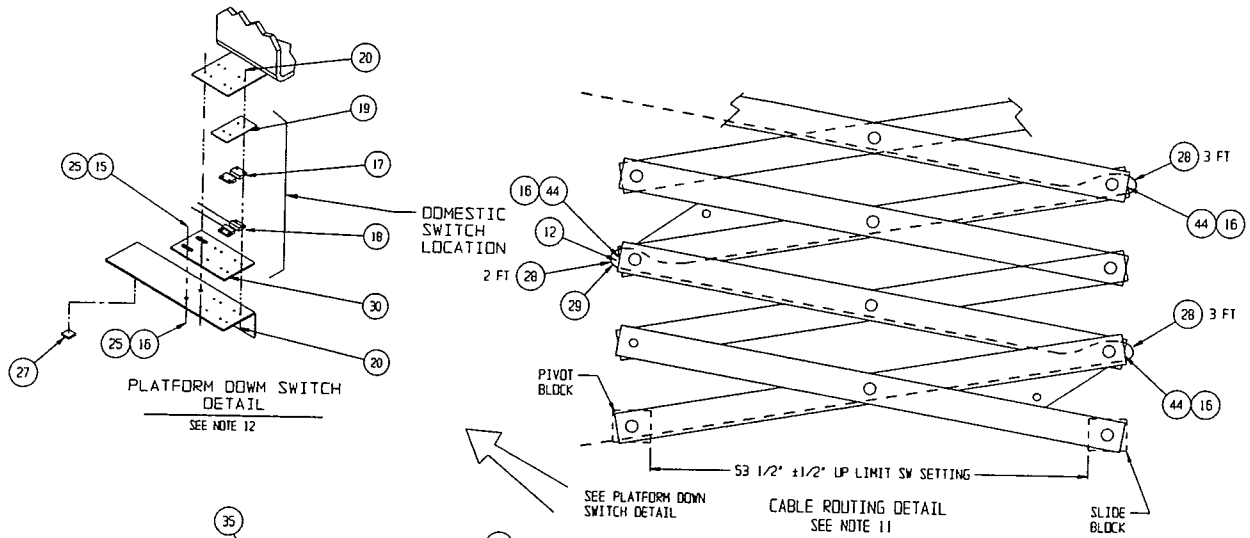

Final Assembly, LX50
Drawing 1 of 3

ILLUSTRATED PARTS BREAKDOWN

Final Assembly, LX50
Drawing 2 of 3

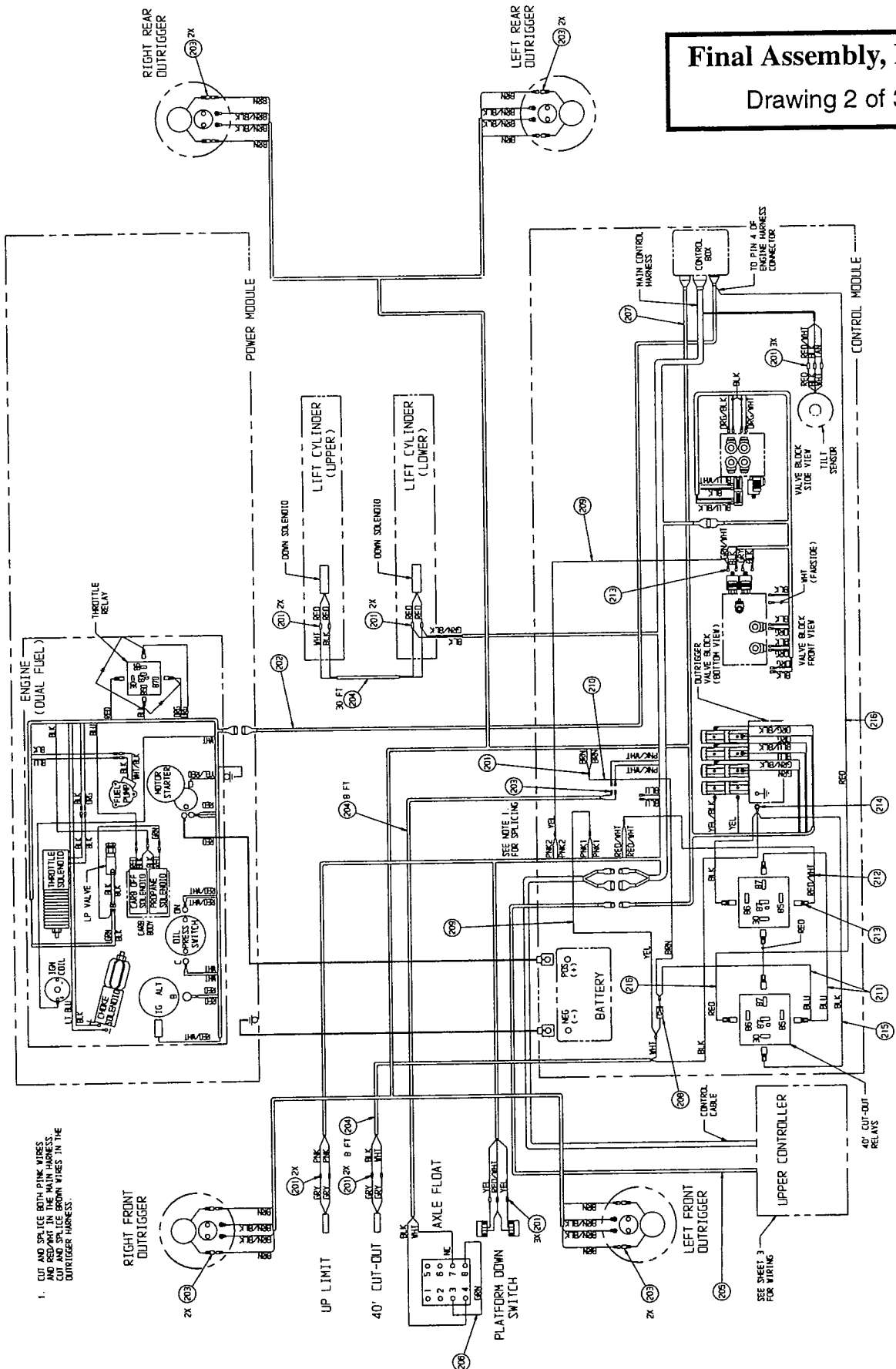

1. CUT AND SPlice BOTH PINK WIRES AND REPAIR IN THE MAIN HARNESS. CUT AND SPlice BROWN WIRES IN THE OUTRIGGER HARNESS.

SEE SHEET 3 FOR WIRING

ILLUSTRATED PARTS BREAKDOWN

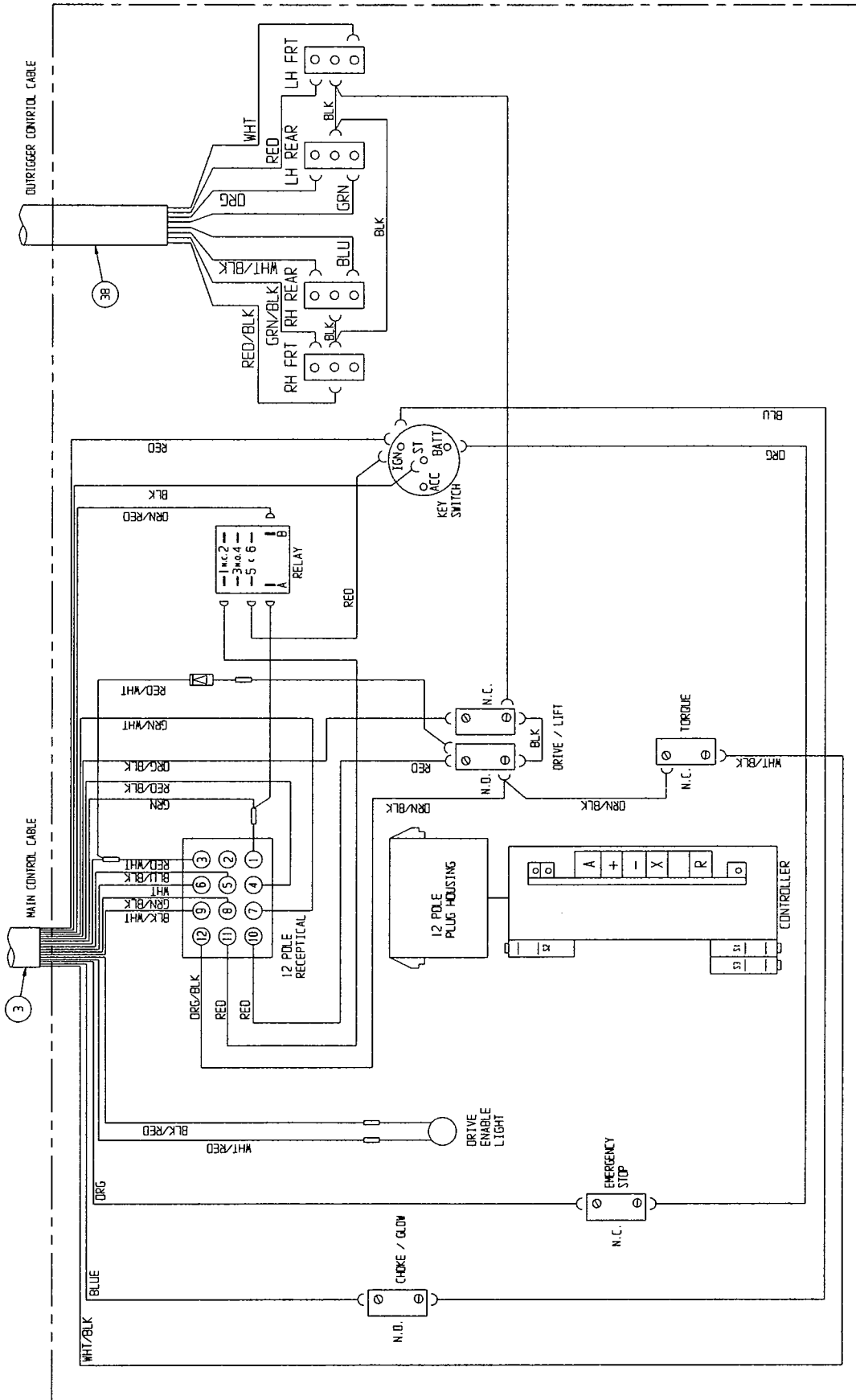

Final Assembly, LX50
Drawing 3 of 3

**FINAL ASSEMBLY, LX50 FOUR-WHEEL
DIESEL, DUAL DECK**

067411-010

ITEM	PART NO.	DESCRIPTION	QTY.
1	067420-000	BASIC ASSY	1
2	067528-011	CONTROLLER ASSEMBLY (DOM)	1
3	067536-012	CONTROL CABLE ASSEMBLY	1
4	067532-131	LABEL-KIT (DOM)	1
5	067533-025	HOSE-KIT	1
6	030841-300	GUARDRAIL	1
7	067522-013	POWER MODULE ASSEMBLY	1
8	067521-031	CONTROL MODULE ASSEMBLY (DOM)	1
9	067534-017	HYDRAULIC SCHEMATIC (DOM)	REF
10	067535-061	ELECTRICAL SCHEMATIC (DOM)	REF
11	067866-001	SLIDE-OUT DECK INSTL	1
12	067692-000	CLIP, CABLE RETAINER	4
14	029945-013	LEVEL SENSOR	1
15	011252-006	SCRW, 1/4-20 X 3/4	4
16	011248-004	LOCKNUT, 1/4-20 UNC	13
17	065373-005	MAGNET	2
18	065373-006	SWITCH	2
19	067913-000	ALUM. SW. PAD	1
20	026551-005	RIVET 1/8 X 1/4 GRIP	8
23	063497-001	MERCURY SWITCH	2

ITEM	PART NO.	DESCRIPTION	QTY.
24	013919-013	CLAMP	2
25	014996-004	WASHER, 1/4 SAE FLAT	8
26	067866-002	SLIDE OUT DECK -REAR	1
27	013283-002	CABLE MOUNT	4
28	067482-000	OUTRIGGER INSTALLATION	1
29	012865-099	WIRE LOOM 3/4 DIA	8
30	067863-000	SWITCH MOUNT	1
31	00942-000	ORBIT LEVEL	1
32	064794-000	LEVEL MOUNT	1
34	067758-099	NYLON HOSE GUARD	11.67 FT
35	067699-000	HOSE CLAMP CHANNEL	2
40	014924-008	U-BOLT	2
41	011721-008	SCREW, RND HD, MACH., 4-40 X 1	3
42	005133-000	SPRING	3
44	011248-049	NUT, HEX, 4-40 ESNA	3
45	020398-012	CLAMP, CUSHIONED, Ø 1 1/2	5
47	068132-001	RELAY - 12 VDC	2
48	011826-006	SCREW - #10-32 X 3/4	2
49	011249-003	NUT - #10-32 HEX	2

NOTES:

1. HYDRAULIC PRESSURE SETTING
FORWARD COUNTER BALANCE - 500 PSI
REVERSE COUNTER BALANCE - 500 PSI
DRIVE MOTOR RELIEF - 3000 PSI
STEERING - 1500 PSI
2. ENGINE SPEED
FULL THROTTLE - 3000 ±50 RPM
IDLE SPEED - 1350 ±50 RPM
3. DRIVE SPEED
SLOW - .30-.35 MPH (38-45 SEC. @ 20 FT.)
HIGH - 2.9-3.1 MPH (4.4-4.7 SEC. @ 20 FT.)
4. LIFT SPEED
UP - 90 SECONDS DOWN - 120 SECONDS
5. PROOF LOAD - 1125 LBS.
6. RATED LOAD - 750 LBS./340 KG.

7. GRADABILITY 24% MIN. (2900 LBS. DRAWBAR PULL)
8. CAUTION:
MAKE SURE THAT PUMP IS FILLED WITH HYDRAULIC OIL PRIOR TO OPERATION, OR SERIOUS DAMAGE WILL OCCUR.
9. CHECK THAT POLYFILL TIRES ARE USED.
10. SET MERCURY SWITCH (DRIVE CUT-OUT) TO OPEN @ 8 METERS (26'-3") FOR EURO AND 40' FOR DOM.
11. SET MERCURY SWITCH (UP LIMIT) TO OPEN AT SPECIFIED DIMENSION TO PREVENT FULL EXTENSION OF LIFT CYL.
12. SWITCH TO OPEN LESS THAN 2 FT. PLATFORM LIFT.
13. BLEED AIR OUT OF BRAKES.

ILLUSTRATED PARTS BREAKDOWN

Section 6.1

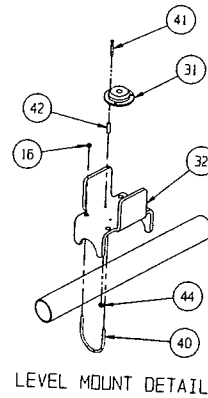
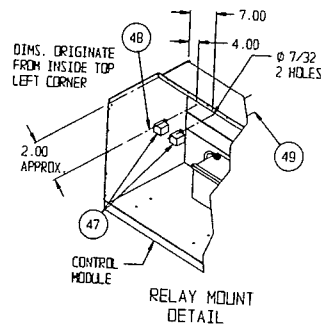
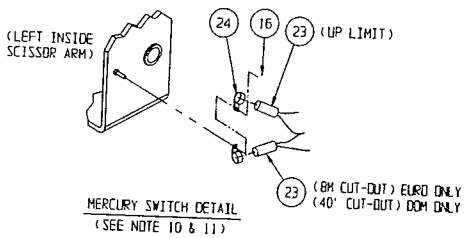
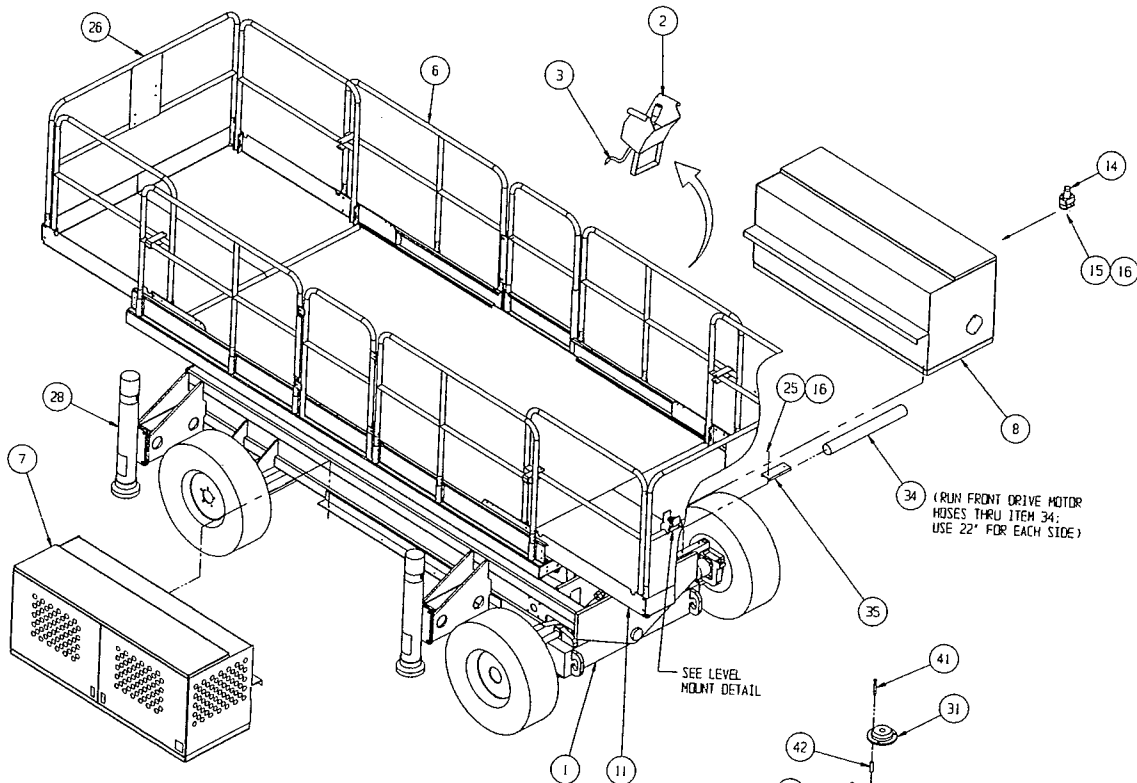
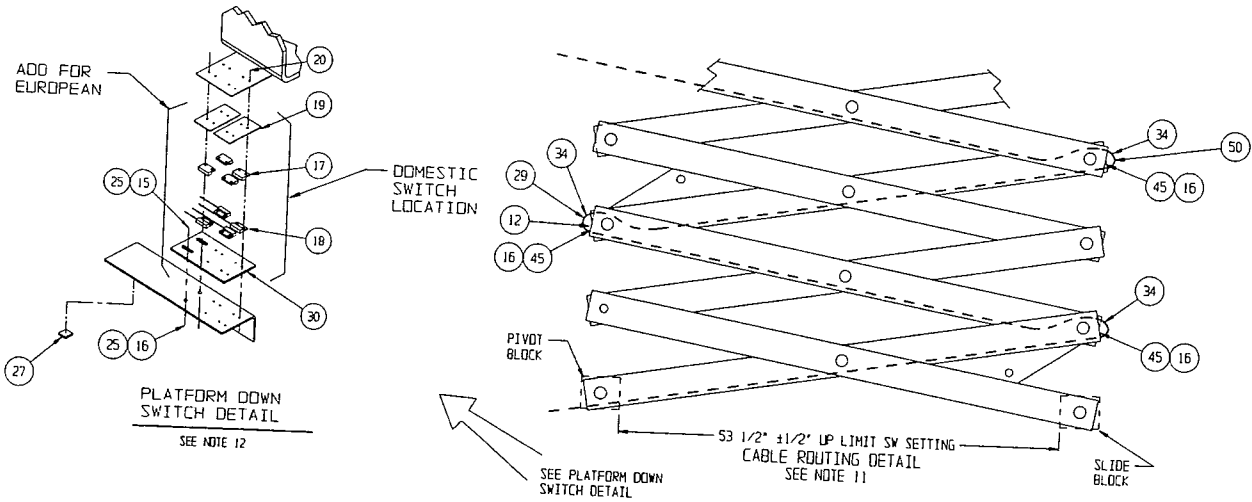

Final Assembly, LX50

Drawing 1 of 3

ILLUSTRATED PARTS BREAKDOWN

Final Assembly, LX50

Drawing 2 of 3

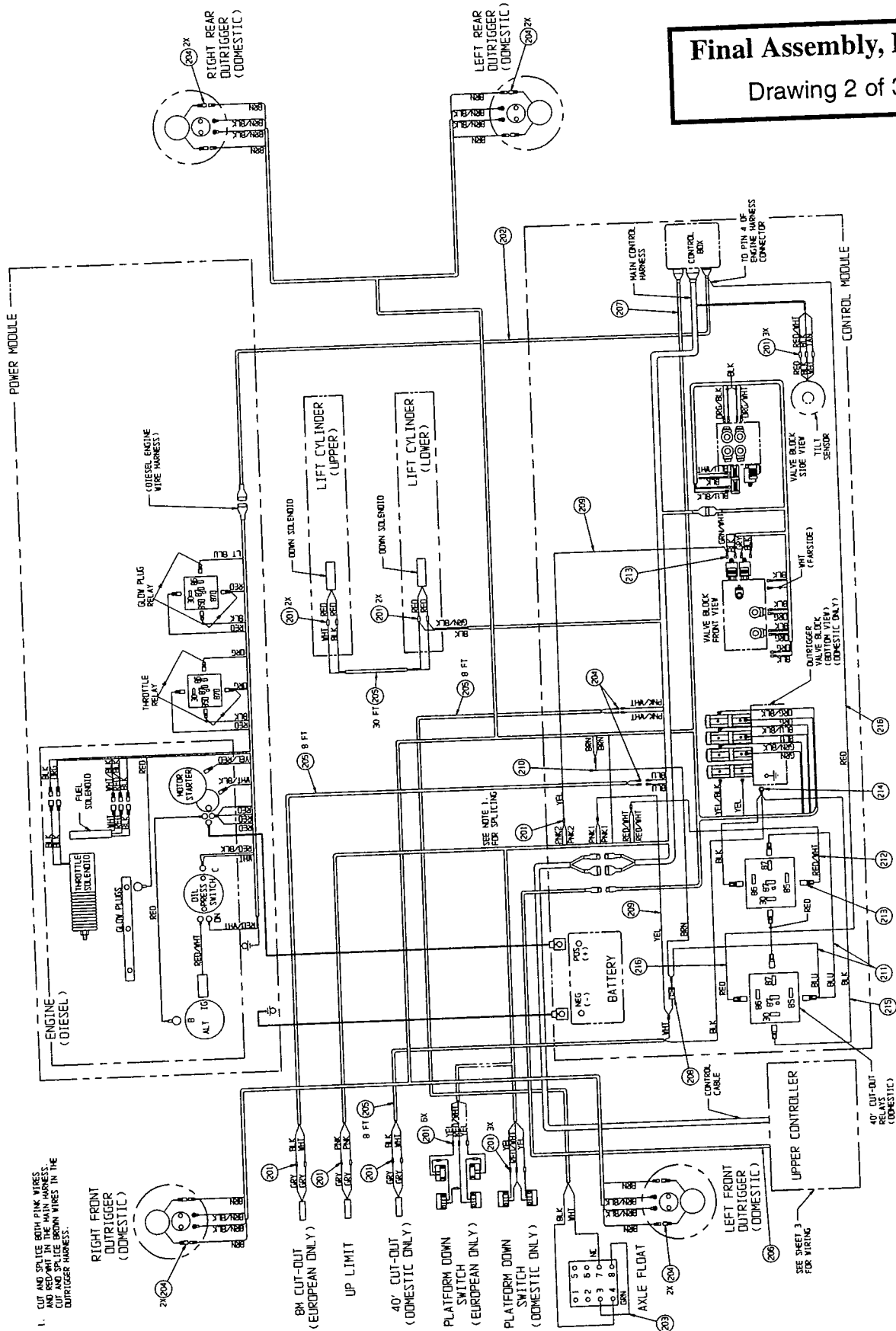

1. CUT AND SPlice BOTH PINK WIRES AND RED WIRE IN THE MAIN HARNESS. CUT AND SPlice BROWN WIRES IN THE OUTRIGGER HARNESS.

ILLUSTRATED PARTS BREAKDOWN

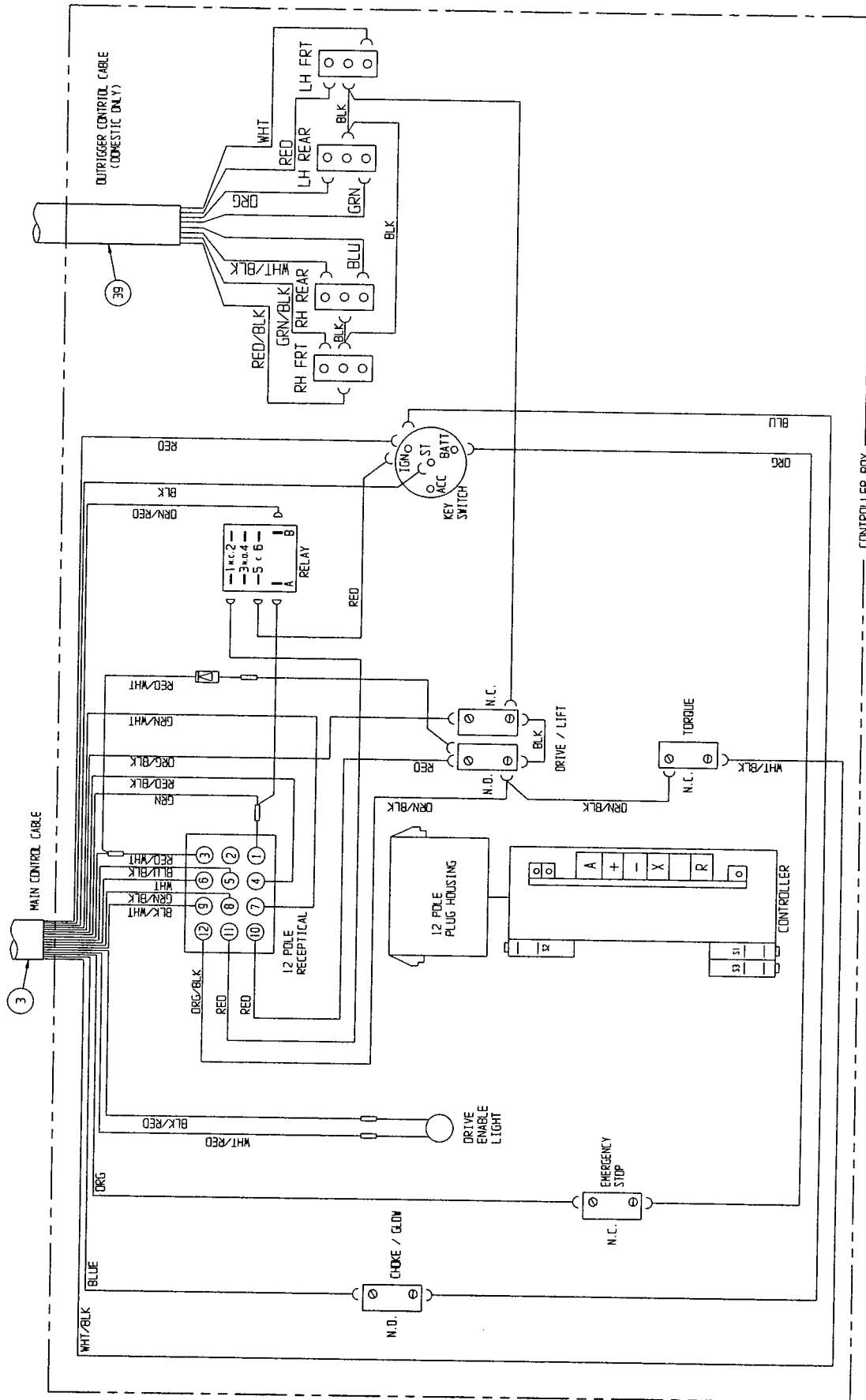

Final Assembly, LX50
Drawing 3 of 3

**Section
6.1**

ILLUSTRATED PARTS BREAKDOWN

**BASIC ASSEMBLY, LX50
TWO-WHEEL DRIVE, STANDARD DECK
067508-001**

ITEM	PART NO.	DESCRIPTION	QTY.
1	067518-001	CHASSIS ASSEMBLY	1
2	067424-000	SCISSOR LINKAGE	1
3	067780-001	PLATFORM WELDMENT	1
4	067879-000	MOTOR COVER	2
5	011253-008	SCR HHC 5/16 X 1	8
6	067962-000	LADDER WELDMENT	1
7	067738-000	SLIDE BLOCK	6
8	067852-000	PIN	4
9	067853-000	PIN	2
10	014996-005	WASHER 5/16 DIA	8
11	066189-000	SPACER 1/4	4
12	067853-001	PIN	2
13	066189-004	SPACER 1/8	8
14	011248-008	NUT 1/2-13 ESNA	16
15	011256-012	SCREW HHC 1/2-13 X 1 1/2	4
16	011296-028	SCREW SHC 1/2-13 X 3 1/2	8
17	014033-032	SCREW HHC 1/2-13 X 4 GR.8	8

**BASIC ASSEMBLY, LX50
FOUR-WHEEL DRIVE, STANDARD DECK
067509-001**

ITEM	PART NO.	DESCRIPTION	QTY.
1	067519-001	CHASSIS ASSEMBLY	1
2	067424-000	SCISSOR LINKAGE	1
3	067780-001	PLATFORM WELDMENT	1
4	067879-000	MOTOR COVER	2
5	011253-008	SCR HHC 5/16 X 1	8
6	067962-000	LADDER WELDMENT	1
7	067738-000	SLIDE BLOCK	6
8	067852-000	PIN	4
9	067853-000	PIN	2
10	014996-005	WASHER 5/16 DIA	8
11	066189-000	SPACER 1/4	2
12	067853-001	PIN	2
13	066189-004	SPACER 1/8	8
14	011248-008	NUT 1/2-13 ESNA	16
15	011256-012	SCREW 1/2-13 X 1 1/2	4
16	011296-028	SCREW SHC 1/2-13 X 3 1/2	8
17	014033-032	SCREW HHC 1/2-13 X 4	8

ILLUSTRATED PARTS BREAKDOWN

Section 6.1

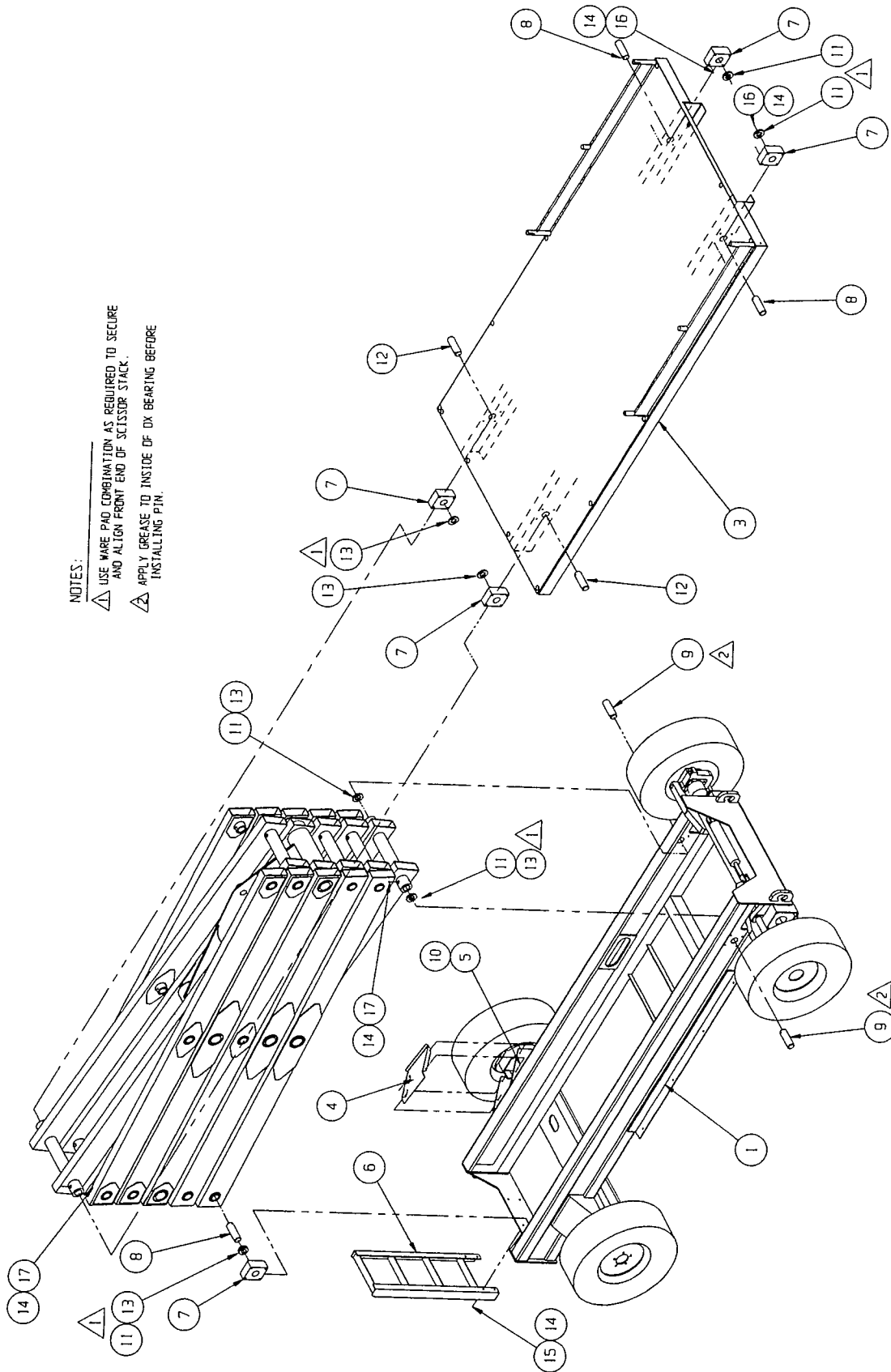

NOTES:

- ▲ USE WARE PAD COMBINATION AS REQUIRED TO SECURE AND ALIGN FRONT END OF SCISSOR STACK.
- ▲ APPLY GREASE TO INSIDE OF OX BEARING BEFORE INSTALLING PIN.

**Section
6.1**

ILLUSTRATED PARTS BREAKDOWN

**BASIC ASSEMBLY, LX50
TWO-WHEEL DRIVE, DUAL DECK
067419-000**

**BASIC ASSEMBLY, LX50
FOUR-WHEEL DRIVE, DUAL DECK
067420-000**

ITEM	PART NO.	DESCRIPTION	QTY.
1	067518-001	CHASSIS ASSEMBLY	1
2	067424-000	SCISSOR LINKAGE	1
3	030841-101	PLATFORM WELDMENT	1
4	067879-000	MOTOR COVER	2
5	011253-008	SCR HHC 5/16 X 1	8
7	067738-000	SLIDE BLOCK	6
8	067852-000	PIN	4
9	067853-000	PIN	2
10	014996-005	WASHER 5/16 DIA	8
11	066189-000	SPACER 1/4	4
12	067853-001	PIN	2
13	066189-004	SPACER 1/8	8
16	011296-028	SCREW SHC 1/2-13 X 3 1/2	8
17	014033-032	SCREW HHC 1/2-13 X 4 GR.8	8
20	011248-008	NUT 1/2-13 ESNA	12

ITEM	PART NO.	DESCRIPTION	QTY.
1	067519-001	CHASSIS ASSEMBLY	1
2	067424-000	SCISSOR LINKAGE	1
3	030841-101	PLATFORM WELDMENT	1
4	067879.000	MOTOR COVER	2
5	011253-008	SCR HHC 5/16 X 1	8
7	067738-000	SLIDE BLOCK	6
8	067852-000	PIN	4
9	067853-000	PIN	2
10	014996-005	WASHER 5/16 DIA	8
11	066189-000	SPACER 1/4	2
12	067853-001	PIN	2
13	066189-004	SPACER 1/8	8
16	011296-028	SCREW SHC 1/2-13 X 3 1/2	8
17	014033-032	SCREW HHC 1/2-13 X 4	8
20	011248-008	NUT 1/2-13 ESNA	12

ILLUSTRATED PARTS BREAKDOWN

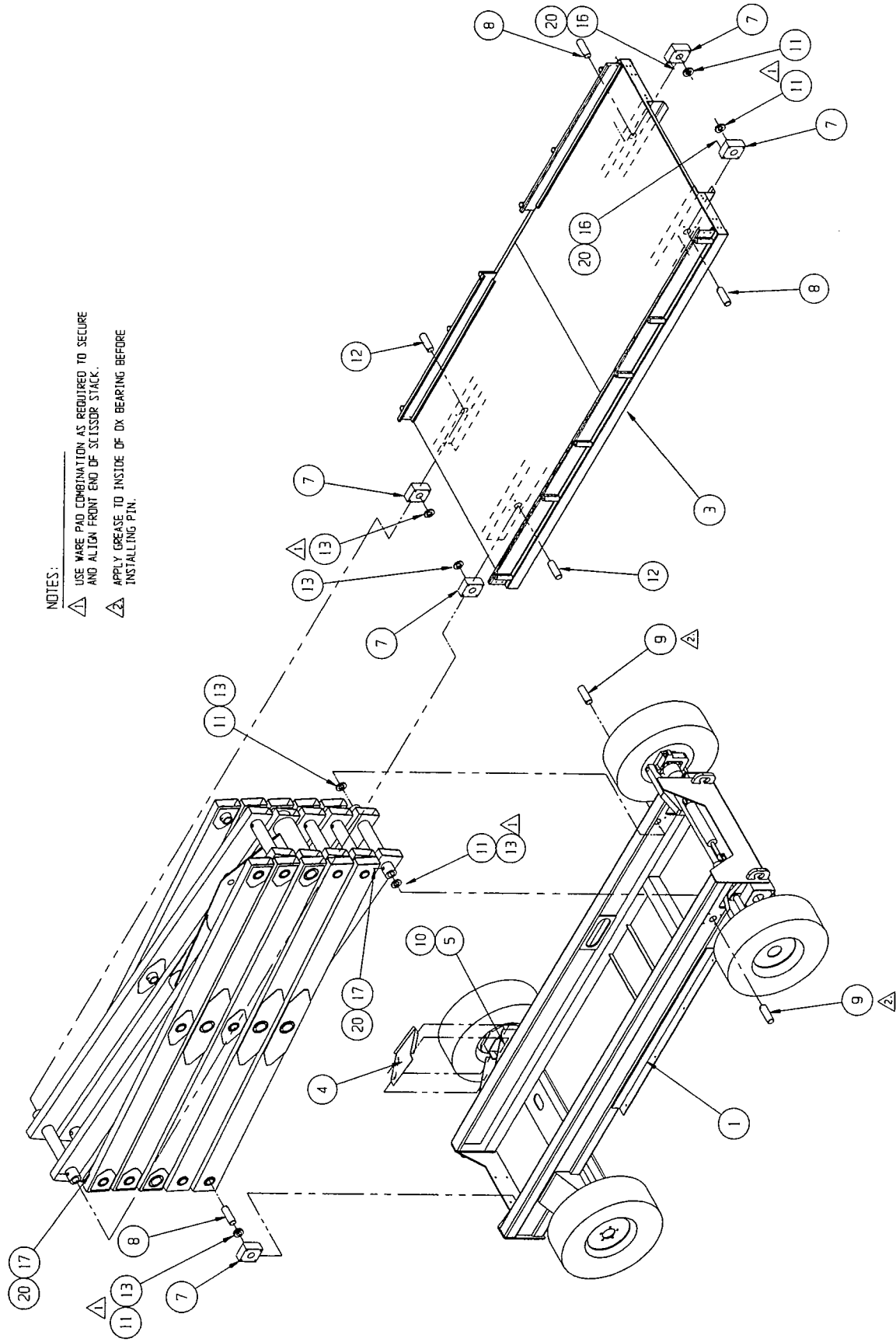

NOTES:

- ▲ USE WARE PAD COMBINATION AS REQUIRED TO SECURE AND ALIGN FRONT END OF SCISSOR STACK.
- ▲ APPLY GREASE TO INSIDE OF DX BEARING BEFORE INSTALLING PIN.

ILLUSTRATED PARTS BREAKDOWN

CHASSIS ASSEMBLY, LX50

TWO-WHEEL DRIVE

067518-001

ITEM	PART NO.	DESCRIPTION	QTY.
1	067715-000	CHASSIS WELDMT (FIXED AXLE)	1
2	067743-000	TRUNNION (L.H.)	1
3	067742-000	TRUNNION (R.H.)	1
4	067739-000	STEERING LINK	1
5	067812-000	BUSHING, STEERING	2
6	067813-000	CONNECTING LINK	2
7	067746-000	TRUNNION PIN LOWER	2
8	067833-000	SPINDLE WELDMENT	2
9	067748-000	STEERING CLAMP	1
11	067816-000	PLATE WELDMENT	1
12	067613-000	HUB, 8 BOLT ON 8" B.C.	2
*	067613-010	GREASE SEAL	1
*	067613-011	INNER CUP	1
*	067613-012	OUTER CUP	1
*	067613-013	INNER CONE	1
*	067613-014	OUTER CONE	1
*	067613-015	DUST CAP	1
*	067613-016	STUD	1
13	067600-000	TORQUE HUB	2
*	067600-010	BEARING	2
*	067600-011	SHAFT SEAL	2
*	067600-012	STUD	10
*	067600-013	O-RING	2
14	067603-000	BRAKE	2
*	067603-010	BRAKE SEAL KIT	-
15	067601-001	HYDRAULIC MOTOR	2
*	067601-010	HYDRAULIC MOTOR SEAL KIT	-
16	067633-000	STEERING CYLINDER	1
*	067633-010	STEERING CYLINDER SEAL KIT	-
17	011252-020	SCREW HHC 1/4-20 X 2 1/2	4
19	011248-004	NUT 1/4-20 HEX ESNA	4
20	067606-020	BEARING, SCISSOR PIVOT	2
21	062642-020	BUSHING 16DU16	4
22	062649-020	BEARING, STEERING ROD	2
23	067606-010	BEARING, 16DX16	6
24	067665-002	TIRE & WHEEL ASSY FRONT RHD	1
25	067665-003	TIRE & WHEEL ASSY FRONT LHD	1

ITEM	PART NO.	DESCRIPTION	QTY.
26	011254-020	SCREW HHC 3/8-16 X 2 1/2	6
27	011248-006	NUT 3/8-16 HEX ESNA	6
28	011258-012	SCREW HHC 3/4-10 X 1 1/2	4
29	011238-008	WASHER 1/2 SPLIT LOCK	33
30	011256-012	SCREW HHC 1/2-13 X 1 1/2	16
31	011257-028	SCREW HHC 5/8-11 X 3 1/2	2
32	011248-008	NUT 1/2-13 HEX ESNA	10
33	011256-024	SCREW HHC 1/2-13 X 3	8
34	011848-050	PIN CLEVIS 1 X 2 3/4	1
35	067746-001	PIN STEERING LINK	2
36	011256-020	SCREW HHC 1/2-13 X 2 1/2	2
37	013315-011	RETAINING "E" RING	2
38	062889-012	PIN, HAIR COTTER .177 X 3 1/2	2
39	011935-006	FITTING 10 MB - 10 MJ 45°	2
40	011469-005	LUG NUT 9/16-18	10
41	011934-011	FITTING, 10 MB - 10 MJ 90°	4
42	011934-001	FITTING, 4 MB - 4 MJ 90°	3
43	011934-003	FITTING, 6 MB - 4 MJ 90°	2
44	012030-010	SCRW SOC HD CAP 1/2-13 X 1-1/4	8
45	011848-051	PIN CLEVIS 1 DIA. X 2	1
46	063978-000	HAND PUMP	1
47	011240-006	WASHER 3/8 STD	2
48	012877-008	VALVE, BI DIRECTIONAL RELIEF	2
49	012030-032	SCRW SOC HD CAP 1/2-13 X 4	4
50	067746-002	PIN TRUNNION UPPER	2
51	067666-002	TIRE/WHEEL ASSY REAR RHD	1
52	067666-003	TIRE/WHEEL ASSY REAR LHD	1
53	011941-001	FITTING 4MB-4MJ STR	1
54	011238-012	WASHER SPLIT LOCK 3/4	4
55	064279-000	THRUST WASHER	2
56	011248-010	NUT 5/8-11 HEX ESNA	2
57	067805-099	GROMMET MATL	FT 7.00
58	024501-003	SHEET 1/8 RUBBER 3 X 48	1
59	020495-009	NUT HEX JAM 9/16-18UNF	1
60	067961-000	VALVE POPET N.C.	1
61	011937-003	FITTING 6FJX-6MJ 90	1

*Not Shown

ILLUSTRATED PARTS BREAKDOWN

Section 6.1

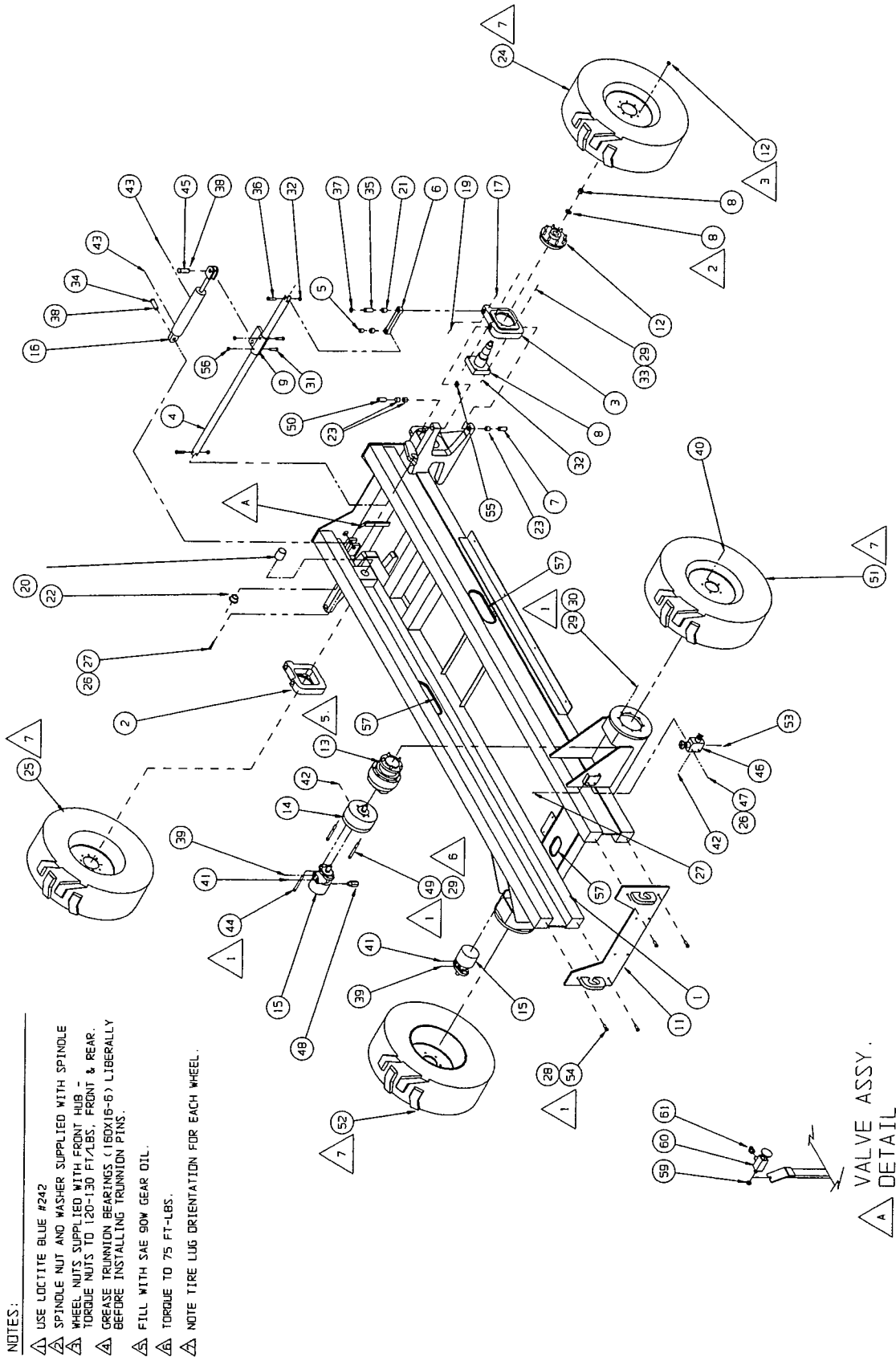

NOTES:

- ▲ USE LOCTITE BLUE #242
- ▲ SPINDLE NUT AND WASHER SUPPLIED WITH SPINDLE
- ▲ WHEEL NUTS SUPPLIED WITH FRONT HUB - TORQUE NUTS TO 120-130 FT-LBS. FRONT & REAR.
- ▲ GREASE TRUIMON BEARINGS (150X16-6) LIBERALLY BEFORE INSTALLING TRUIMON PINS.
- ▲ FILL WITH SAE 90W GEAR OIL.
- ▲ TORQUE TO 75 FT-LBS.
- ▲ NOTE TIRE LUG ORIENTATION FOR EACH WHEEL.

▲ VALVE ASSY. DETAIL

**Section
6.1**

ILLUSTRATED PARTS BREAKDOWN

CHASSIS ASSEMBLY, LX50

FOUR-WHEEL DRIVE

067519-001

ITEM	PART NO.	DESCRIPTION	QTY.
1	067729-000	CHASSIS WELDMENT	1
2	067700-000	AXLE WELDMENT	1
3	067743-000	TRUNNION (L.H.)	1
4	067742-000	TRUNNION (R.H.)	1
5	067739-000	STEERING LINK	1
6	067812-000	BUSHING, STEERING	2
7	067813-000	CONNECTING LINK	2
8	067746-000	TRUNNION PIN	2
9	067814-000	PIVOT SHAFT, FRONT AXLE	1
10	067748-000	STEERING CLAMP	1
11	011238-012	LOCKWASHER SPLIT 3/4	4
12	067816-000	PLATE WELDMENT	1
13	067607-002	HYDRAULIC MOTOR (FRONT)	2
14	067600-000	TORQUE HUB	2
*	067600-010	BEARING	2
*	067600-011	SHAFT SEAL	2
*	067600-012	STUD	10
*	067600-013	O-RING	2
15	067603-000	BRAKE	2
*	067603-010	BRAKE SEAL KIT	-
16	067601-001	HYDRAULIC MOTOR	2
*	067601-010	HYDRAULIC MOTOR SEAL KIT	-
17	067633-000	STEERING CYLINDER	1
*	067633-010	STEERING CYLINDER SEAL KIT	-
18	067634-000	AXLE PIVOT CYLINDER	1
*	067634-010	AXLE PIVOT CYLINDER SEAL KIT	-
19	067637-000	PIVOT BUSHING	2
20	027931-057	BEARING, PIVOT CYL.	2
21	067606-020	BEARING, SCISSOR PIVOT	2
22	064298-004	BEARING, AXLE PIVOT	2
23	062649-020	BEARING, STEERING ROD	2
24	067606-010	BEARING 16DX16	6
25	067666-002	TIRE & WHEEL - RH	1
26	067666-003	TIRE & WHEEL - LH	1
27	067664-002	TIRE & WHEEL - RH 4WD FRONT	1
28	067664-003	TIRE & WHEEL - LH 4WD FRONT	1
29	011252-020	SCREW, HHC 1/4-20UNC X 2-1/2	6
30	011248-004	NUT, HEX 1/4-20 ESNA	6
31	062642-020	BEARING, 16 DU 12	4
32	067746-001	STEERING LINK PIN	2
33	011254-020	SCREW, HHC 3/8-16UNC X 2-1/2	6
34	011248-006	NUT, HEX 3/8-16UNC ESNA	6
35	062889-012	PIN, HAIR COTTER .177 X 3-1/2	2
36	011848-050	PIN, CLEVIS 1 X 2-3/4	1
37	013315-011	RETAINING "E" RING	2
38	011256-020	SCREW, HHC 1/2-13UNC X 2-1/2	2
39	011248-008	NUT, HEX 1/2-13UNC ESNA	19

ITEM	PART NO.	DESCRIPTION	QTY.
40	011256-028	SCREW, HHC 1/2-13UNC X 3-1/2	2
41	011256-012	SCREW, HHC 1/2-13UNC X 1-1/2	17
42	011238-008	LOCKWASHER, SPLIT 1/2	37
43	011249-016	LOCKNUT, HEX 1-14UNF ESNA	4
44	011297-016	WASHER, BELL 1"	4
45	064370-001	CYLINDER PIN 1 X 5-1/4	2
46	011258-012	SCREW, HHC 3/4-10UNC X 1-1/2	4
47	012030-032	SCREW, SOC HD 1/2-13UNC X 4	8
48	011469-005	LUG NUT, 9/16-18 90°	10
49	012004-004	FITTING, PLUG SAE#4	4
50	015961-004	FITTING, TEE 4MB - 4MJ - 4MJ	2
51	011934-001	FITTING, 90° 4MB - 4MJ	7
52	011937-001	FITTING, 90° 4FJX - 4MJ	2
53	015961-010	FITTING, TEE 10MB - 10MJ-10MJ	1
54	010150-005	FITTING, BULKHD. 8MJ - 8MJ	4
55	011941-014	FITTING, 12MB - 8MJ	2
56	011935-006	FITTING, 45° 10MB - 10MJ	2
57	011934-011	FITTING, 90° 10MB - 10MJ	1
58	011934-003	FITTING, 90° 6MB - 4MJ	2
59	012030-010	SCREW SOC HD 1/2-13 X 1-1/4	8
60	067878-000	AXLE COVER 4WD	1
61	067674-008	FITTING 45° 12MB - 8MJ	4
62	064296-003	LIMIT SWITCH	1
63	064294-004	CLAMP LEVER	1
64	012002-010	FITTING 10MJ - 10MJ 90°	4
65	064297-001	CHECK VALVE	2
66	011848-051	CLEVIS PIN 1" DIA. X 2"	1
67	063978-000	PUMP HAND (BRAKE)	1
68	011240-006	WASHER 3/8 STD	2
69	012877-008	VALVE BI-DIRECTIONAL RELIEF	2
71	011709-018	SCREW MACH RD HD 10-24 X 2-1/4	4
72	011248-003	NUT HEX ESNA 10-24	4
73	067746-002	TRUNNION PIN UPPER	2
74	011935-003	FITTING 6MB - 6MJ 45°	1
75	011941-005	FITTING 6MB - 6MJ STR	1
76	011252-004	SCREW HHC 1/4-20 X 1/2	2
77	011240-004	WASHER 1/4 FLAT STD	2
78	064279-000	THRUST WASHER	2
79	067805-099	GROMMET MATL	FT 7.00
80	024501-003	SHEET 1/8 RUBBER 3 X 48	1
81	013336-003	FITTING LUBE	4
82	020495-009	NUT HEX JAM 9/16-18UNF	1
83	067961-000	VALVE POPET N.C.	1
84	011937-003	FITTING 6FJX-6MJ 90	1
85	067865-000	WHEEL HUB	2
86	014122-001	WHEEL BOLT	12
87	012030-024	SCREW SOC HD 1/2-13 X 3	8

*Not Shown

ILLUSTRATED PARTS BREAKDOWN

Section 6.1

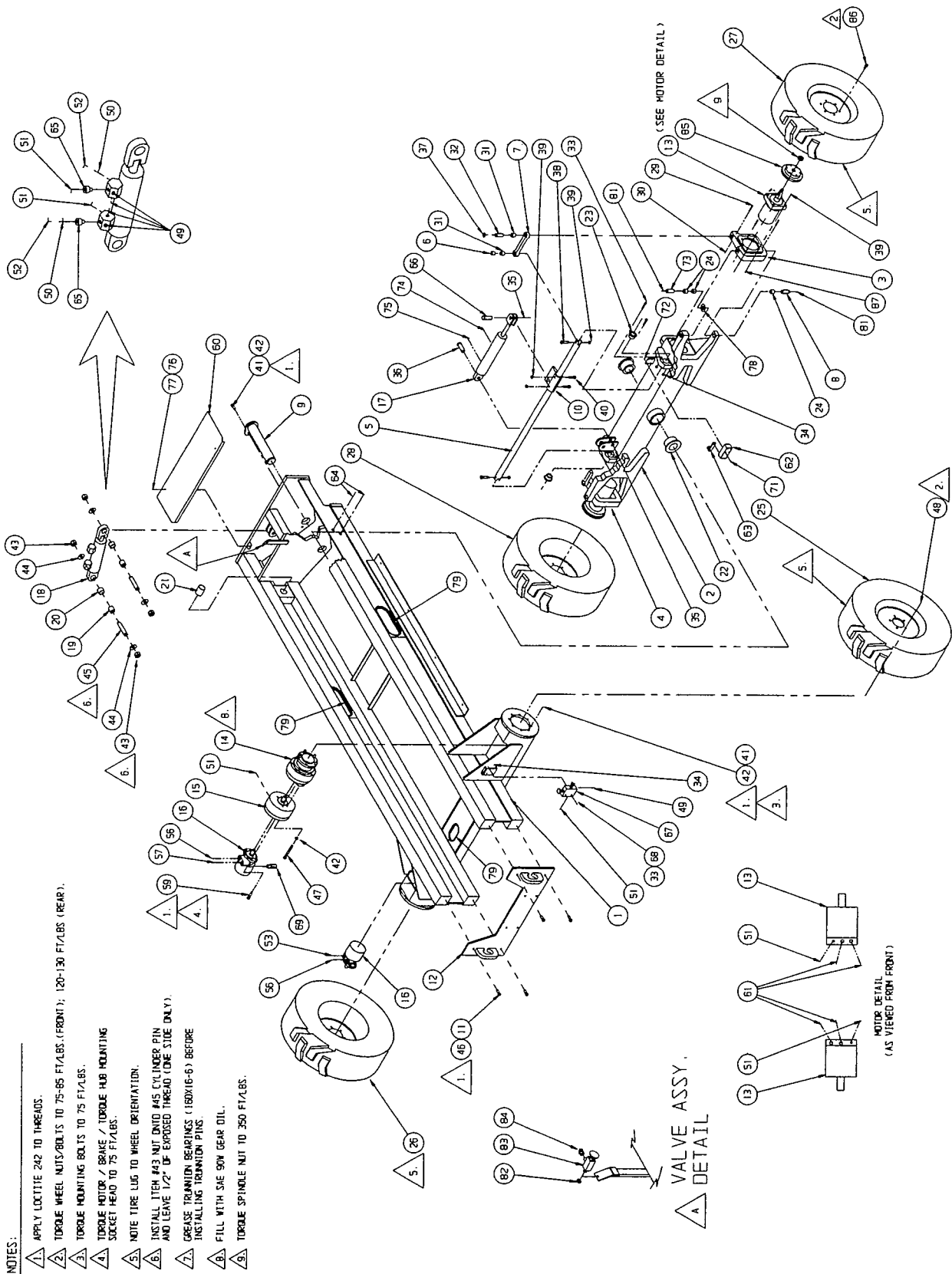

NOTES:

- ▲ APPLY LOCKTITE 242 TO THREADS.
- ▲ TORQUE WHEEL NUTS/BOLTS TO 75-85 FT/LBS. (FRONT); 120-130 FT/LBS (REAR).
- ▲ TORQUE MOUNTING BOLTS TO 75 FT/LBS.
- ▲ TORQUE MOTOR / BRAKE / TORQUE HUB MOUNTING SOCKET HEAD TO 75 FT/LBS.
- ▲ NOTE TIRE LUG TO WHEEL ORIENTATION.
- ▲ INSTALL ITEM #43 NUT OVER #45 CYLINDER PIN AND LEAVE 1/2" OF EXPOSED THREAD (ONE SIDE ONLY).
- ▲ GREASE TRANSMISSION BEARINGS (180X16-6) BEFORE INSTALLING TRANSMISSION PINS.
- ▲ FILL WITH SAE 90W GEAR OIL.
- ▲ TORQUE SPINDLE NUT TO 350 FT/LBS.

**Section
6.1**

ILLUSTRATED PARTS BREAKDOWN

SCISSOR LINKAGE ASSEMBLY, LX50

067424-000

ITEM	PART NO.	DESCRIPTION	QTY.
1	067968-001	ARM WELDMENT	1
2	067969-001	ARM WELDMENT	1
3	067970-000	ARM WELDMENT	1
4	067971-001	ARM WELDMENT	2
5	067972-001	ARM WELDMENT	1
6	067973-000	ARM WELDMENT	2
7	067974-000	ARN WELDMENT	1
8	067975-000	ARM WELDMENT	2
9	067557-000	ARM WELDMENT	1
10	067606-020	BEARING, 2" I.D. X 1 1/2" LG.	44
11	067606-030	BEARING, 3" I.D. X 1 1/2" LG.	8
12	067583-000	PIN WELDMENT	20
13	067580-000	PIN WELDMENT	4
14	067585-000	PIN WELDMENT	2
15	067586-000	PIN, CYLINDER	4
16	067635-005	LIFT CYLINDER	1
*	067635-015	LIFT CYLINDER SEAL KIT	-
17	014033-048	SCREW 1/2-13 UNC X 6 GR. 8	42
18	014033-032	SCREW HHC 1/2-13 UNC X 4 GR. 8	12
19	011248-008	HEX LOCK NUT 1/2-13 UNC	26
20	067591-000	SUPPORT WELDMENT	2
21	013336-001	GREASE FITTING	26
22	011941-005	STRAIGHT ADAPTER #6	2

ITEM	PART NO.	DESCRIPTION	QTY.
23	060291-000	DOWN VALVE	2
24	003570-001	RETAINING PIN ASSLY	1
25	067556-000	ARM WELDMENT	1
26	067976-001	ARM WELDMENT	1
27	015919-006	ORIFICE PLATE	2
28	005133-000	SPRING	2
29	011786-017	MACHINERY BUSHING, 2" ID X 14 GA.	2
30	011757-028	COTTER PIN 3/8 DIA X 3-1/2	2
31	014693-005	FITTING 10FJ-6MJ	2
32	067981-000	FITTING	2
33	067635-004	LIFT CYLINDER	1
*	067635-014	LIFT CYLINDER SEAL KIT	-
34	011256-036	SCREW HHC 1/2-13UNC X 4 1/2	10
35	011248-004	NUT HEX ESNA 1/4-20UNC	2
36	011252-036	SCREW HEX 1/4-20UNC X 4 1/2	2
37	067979-000	SCISSOR BRACE CONNECTOR WELDMENT	1

*Not Shown

ILLUSTRATED PARTS BREAKDOWN

Section 6.1

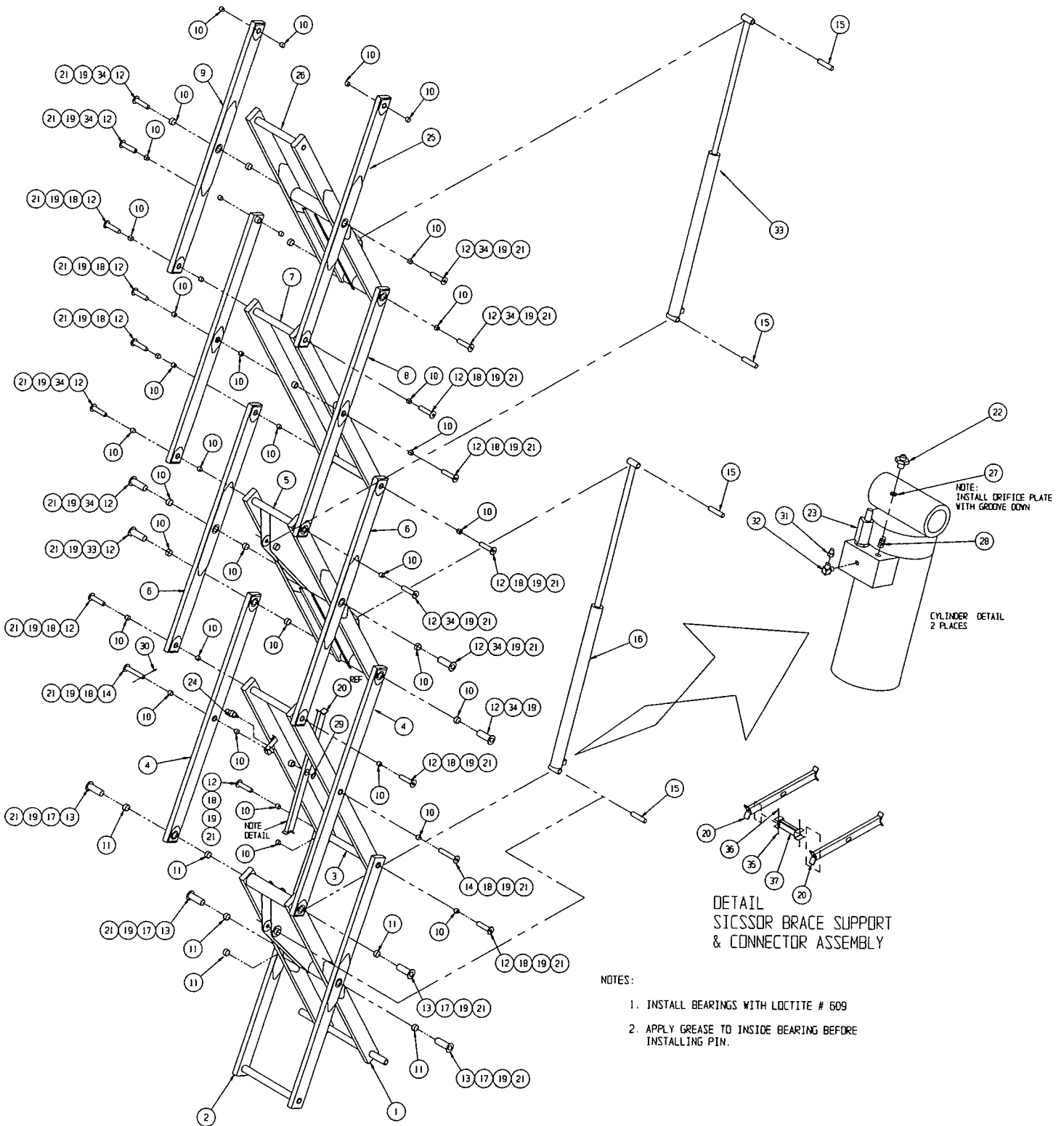

NOTES:

1. INSTALL BEARINGS WITH LOCTITE # 609
2. APPLY GREASE TO INSIDE BEARING BEFORE INSTALLING PIN.

CONTROLLER ASSEMBLY, LX50 W/O OUTRIGGERS 067528-010

ITEM	PART NO.	DESCRIPTION	QTY.
1	067487-000	LX CONTROL BOX	1
2	067643-001	CONTROLLER, PROPORTIONAL 12V	1
*	015772-001	SWITCH, MICRO	1
*	066544-014	SWITCH, STEERING	1
*	063913-003	BOOT, STEERING SWITCH	2
*	063913-004	ROCKER ASSEMBLY	1
*	066544-010	HANDLE, 2 PIECE	1
*	066544-011	LEVER, INTERLOCK	1
*	066544-012	SWITCH, INTERLOCK	1
*	066544-013	BOOT, JOYSTICK SHAFT	1
*	066544-015	FLANGE, CONTROLLER MOUNTING	1
3	067486-000	COVER PLATE, CONTROLLER BOX	1
4	067483-000	CONTROLLER SUPPORT	1
5	029925-011	CABLE CONNECTOR, 3/4"	1
6	064443-002	CONTACT BLOCK, N.C.	3
7	064443-001	CONTACT BLOCK, N.O.	2
8	064666-000	KEY SWITCH	1
*	063936-015	KEY ONLY	1
9	067657-000	SELECTOR SWITCH	2
10	067653-000	PUSH BUTTON	1
11	064446-003	MUSHROOM BUTTON	1
12	068133-000	INDICATOR LIGHT	1

ITEM	PART NO.	DESCRIPTION	QTY.
13	067806-000	RING, RETAINING	1
14	063951-001	RELAY	1
15	029939-003	CONDUIT NUT, 3/4"	1
16	011248-047	LOCKNUT, #6-32	2
17	011715-004	SCREW, #6-32 X 1/2	2
18	064417-001	MOUNTING LATCH	4
19	064462-007	CAP PLUG Ø 7/8	2
20	011252-006	SCREW, 1/4-20 UNC, HEX HD CAP X 3/4	2
21	011248-004	LOCKNUT, 1/4-20 UNC, HEX	2
22	064462-002	CAP PLUG Ø 1/2"	4
23	101158-099	O-RING, Ø 3/32	3 FT.
24	010952-004	SCREW, BUTT. HD, TORX, 10-24 UNC X 1/2	6
100	029610-004	CONNECTOR FORK TERM 12-10 GA. #10	11
102	029615-002	CONNECTOR FEMALE PUSH 16-14 GA.	2
103	063956-003	PLUG, HOUSING	1
104	063956-010	PIN, CONTACT MALE	3
105	029452-099	WIRE 16 GA. BLACK	2 FT
106	029450-099	WIRE 16 GA. BLUE	3 FT
108	029453-099	WIRE 16 GA. ORG	1 FT
109	029477-099	WIRE 16 GA. ORG/BLK	1 FT
110	029454-099	WIRE 16 GA. RED	2 FT

*Not Shown

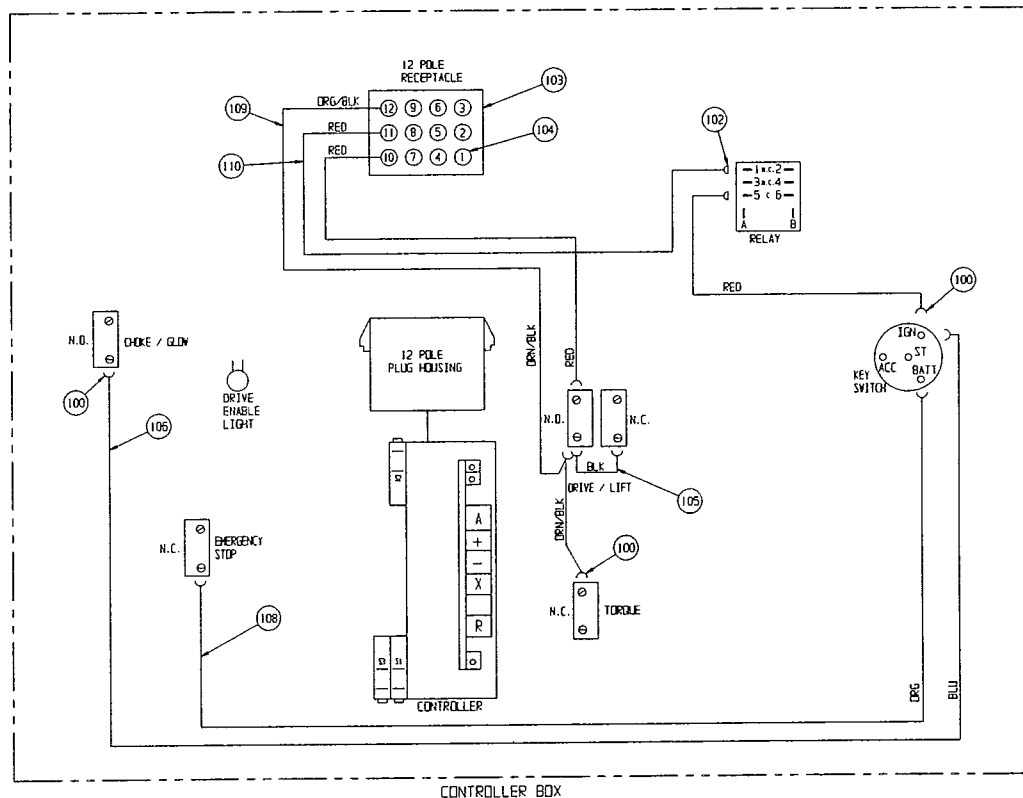

CONTROLLER BOX

ILLUSTRATED PARTS BREAKDOWN

Section 6.1

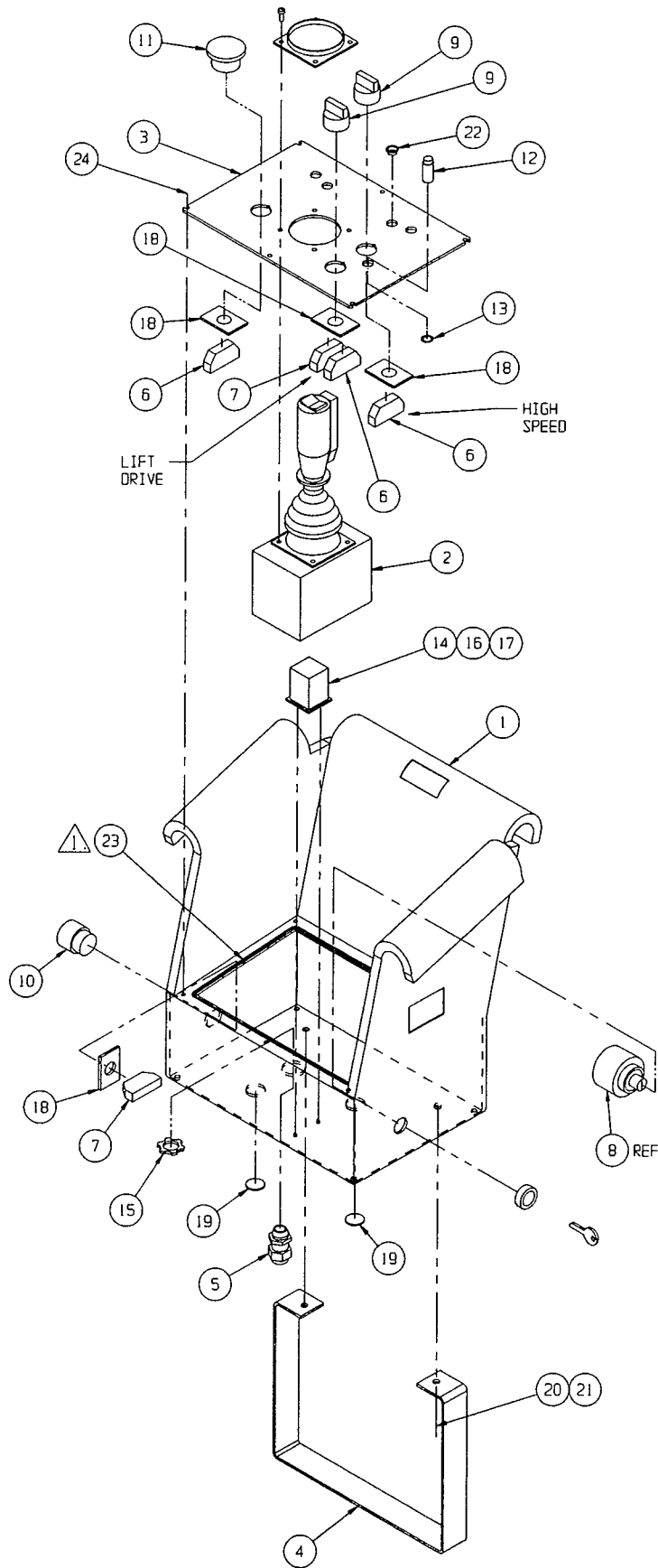

CONTROLLER ASSEMBLY, LX50 W/ OUTRIGGERS

067528-011

ITEM	PART NO.	DESCRIPTION	QTY.
1	067487-000	LX CONTROL BOX	1
2	067643-001	CONTROLLER, PROPORTIONAL 12V	1
3	067486-000	COVER PLATE, CONTROLLER BOX	1
4	067483-000	CONTROLLER SUPPORT	1
5	029925-011	CABLE CONNECTOR, 3/4"	1
6	064443-002	CONTACT BLOCK, N.C.	3
7	064443-001	CONTACT BLOCK, N.O.	2
8	064666-000	KEY SWITCH	1
9	067657-000	SELECTOR SWITCH	2
10	067653-000	PUSH BUTTON	1
11	064446-003	MUSHROOM BUTTON	1
12	068133-000	INDICATOR LIGHT	1
13	067806-000	RING, RETAINING	1
14	063951-001	RELAY	1
15	029939-003	CONDUIT NUT, 3/4"	1
16	011248-047	LOCKNUT, #6-32	2
17	011715-004	SCREW, #6-32 X 1/2	2
18	064417-001	MOUNTING LATCH	4

ITEM	PART NO.	DESCRIPTION	QTY.
19	064462-007	CAP PLUG Ø 7/8	1
20	011252-006	SCREW, 1/4-20 UNC, HEX HD CAP X 3/4	2
21	011248-004	LOCKNUT, 1/4-20 UNC, HEX	2
22	012798-000	TOGGLE SWITCH SPOT-MOMENTARY	4
23	101158-099	O-RING, Ø 3/32	3 FT.
24	010952-004	SCREW, BUTT. HD, TORX, 10-24 UNC X 1/2	6
25	029872-000	SWITCH BOOT	4
26	029925-000	CABLE CONNECTOR, 1/2, NPT	1
27	029939-002	NUT, LOCK, 1/2, NPT	1
100	029610-004	CONNECTOR FORK TERM 12-10 GA. #10	16
102	029615-002	CONNECTOR FEMALE PUSH 16-14 GA.	2
103	063956-003	PLUG, HOUSING	1
104	063956-010	PIN, CONTACT MALE	3
105	029452-099	WIRE 16 GA. BLACK	2 FT
106	029450-099	WIRE 16 GA. BLUE	3 FT
108	029453-099	WIRE 16 GA. ORG	1 FT
109	029477-099	WIRE 16 GA. ORG/BLK	1 FT
110	029454-099	WIRE 16 GA. RED	2 FT

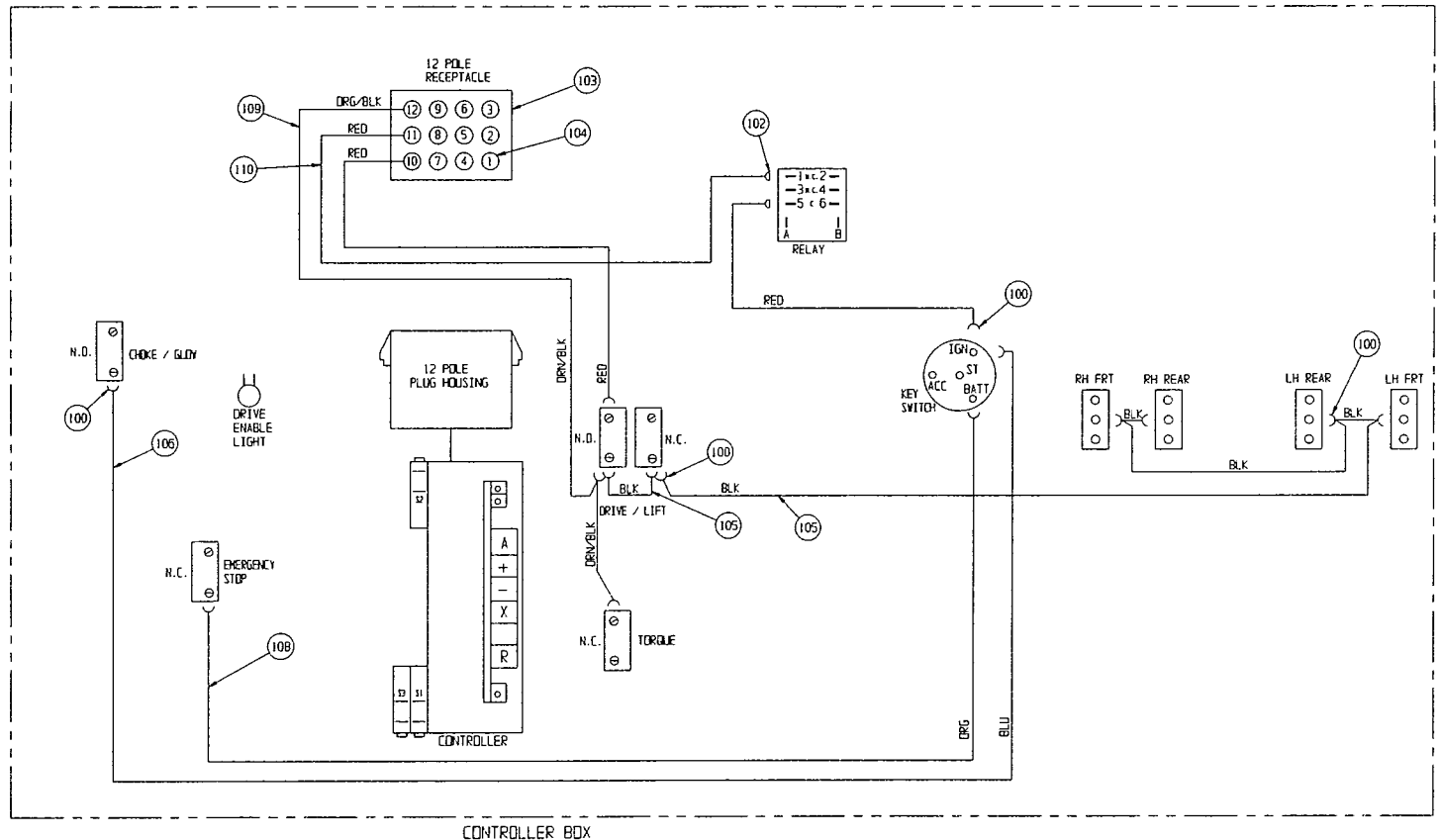

ILLUSTRATED PARTS BREAKDOWN

Section 6.1

⚠️ APPLY LOCTITE #401 IN O-RING GROOVE BEFORE SEATING O-RING, USE SPARINGLY.

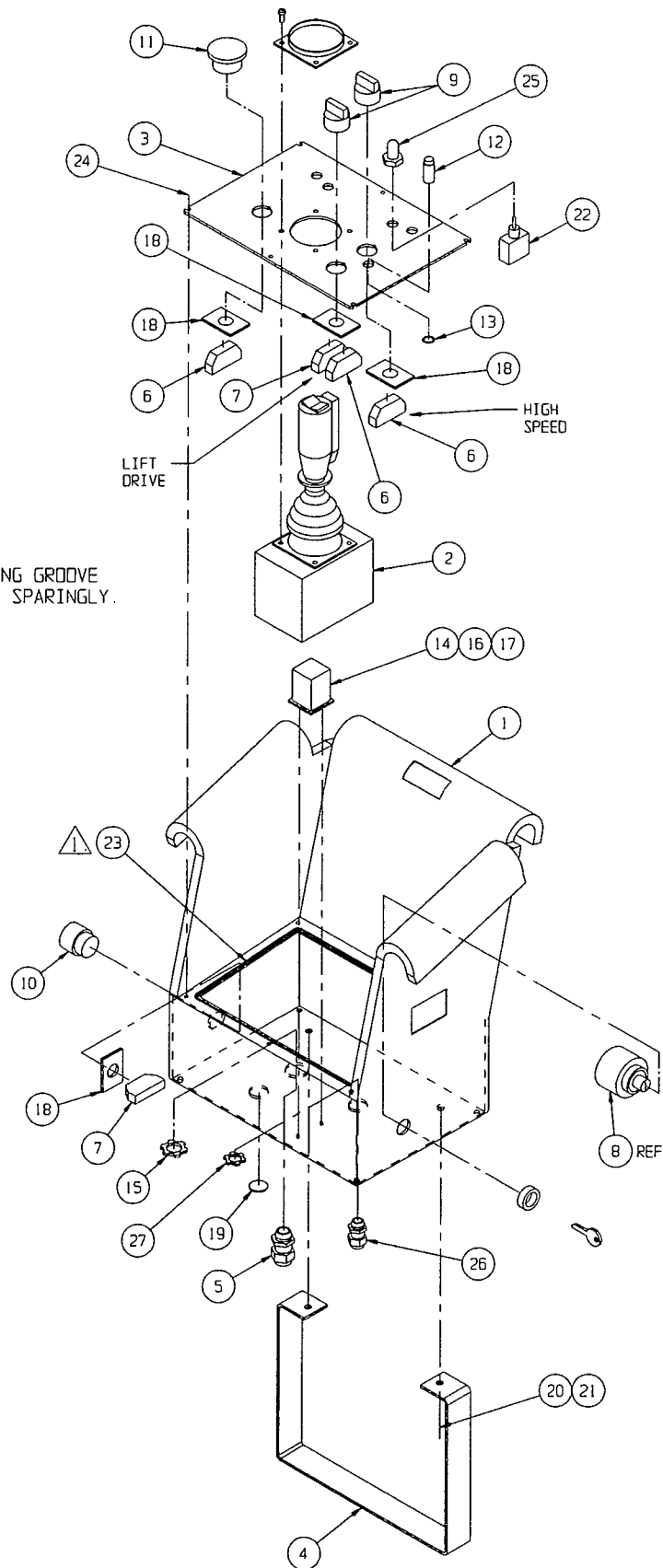

ILLUSTRATED PARTS BREAKDOWN

**CONTROL MODULE ASSEMBLY, LX50
TWO-WHEEL DRIVE DUAL FUEL, STANDARD DECK
067521-020**

ITEM	PART NO.	DESCRIPTION	QTY.
1	067810-003	CONTROL MODULE WELDMENT	1
2	067491-001	CONTROL BOX , D/F	1
3	067485-000	FUEL TANK, ASSEMBLY, GAS	1
4	063650-012	GAS SPRING	1
5	067484-000	CONTROL BOX MOUNT	1
6	067648-008	END FITTING, GAS SPRING	REF
7	067629-000	LATCH, FLUSH LIFT & TURN	2
8	005299-000	LATCH, TOGGLE	2
9	067902-000	BRACKET, GAS SPRING	1
11	014435-001	TERMINAL, BATTERY	2
12	067489-000	VALVE BLOCK ASSY. (2 W.D.)	1
13	012739-099	HOSE, 1/4 I.D.	11 FT
14	067892-000	BRACKET, VALVE BLOCK	1
15	020541-001	HOSE CLAMP	1
16	011254-008	SCRW HHC GR5 3/8-16UNC X 1	10
17	011708-004	SCRW MACH RD HD 8-32UNC X 1/2	4
18	011248-002	LOCK NUT, ESMA 8-32UNC	4
19	064040-000	ANGLE, BATTERY HOLD DOWN	1
20	062299-002	BATTERY, 12 VDC GROUP-27C	1
21	067856-000	WELDMENT, STIFFENER	1
22	012039-000	ROD, BATTERY HOLD DOWN	2
23	025427-002	HANDLE	1
24	011253-008	SCR HHC 5/16-18 X 1	2
25	067808-000	HINGE, 1 1/2 X 23 7/8	2
26	067809-002	HINGE, 1 1/2 X 65	1
27	067799-008	MODULE COVER / CONTROL	1
28	067800-000	MODULE DOOR, R.H.	1
29	067801-000	MODULE DOOR, L.H.	1
30	026554-002	POP RIVET, 1/4 DIA (.251-.375 GRIP)	36
31	011248-006	NUT, 3/8-16 ESNA	7
32	011252-006	SCREW, HHC 1/4-20 X 3/4	2

ITEM	PART NO.	DESCRIPTION	QTY.
33	011248-004	NUT, 1/4-20 ESNA	4
34	011239-006	WASHER, 3/8", SPLIT LOCK	2
35	067854-001	ANGLE, FUEL TANK MOUNT	1
36	011240-006	WASHER, 3/8", STD, FLT	2
37	011254-006	SCREW HHC 3/8-16 X 3/4	2
39	062125-002	CABLE, BATTERY X 69	2
40	011240-004	WASHER 1/4 FLAT	4
41	011254-004	SCRW HHC GR5 3/8-16UNC X 1/2	4
42	011237-006	WASHER 3/8 STAR	1
43	011248-005	NUT, HEX 5/16-18 ESNA	2
44	015936-004	SCR, SHOULDER 3/8 DIA. X 1/2	2
45	011275-006	SCREW HHC 10-32UNF X 3/4"	4
46	011238-002	WASHER SPLIT-LOCK #10	4
47	067492-001	WIRE HARNESS, MAIN CONTROL	1
48	067492-002	WIRE HARNESS, VALVE BLOCK	1
49	029931-003	CONN. FEMALE PUSH, 16-14 AWG, .250 TAB	4
50	029458-099	WIRE 16 AWG, RED	6 IN.
56	067615-049	HOSE ASSY x 100"	1
57	027823-000	TANK MOUNTING BRACKET	1
58	027934-003	FUEL TANK. PROPANE	1
60		FEMALE ADAPTER (PROPANE TANK)	1
61	SUPPLIED WITH ENGINE	FITTING, STIR 2MP-6MJ BRASS	1
62		RELIEF VALVE 400 PSI	1
63		FITTING 2-2-2 STR TEE BRASS	1

**See page 6-66 for
wiring diagram**

ILLUSTRATED PARTS BREAKDOWN

Section 6.1

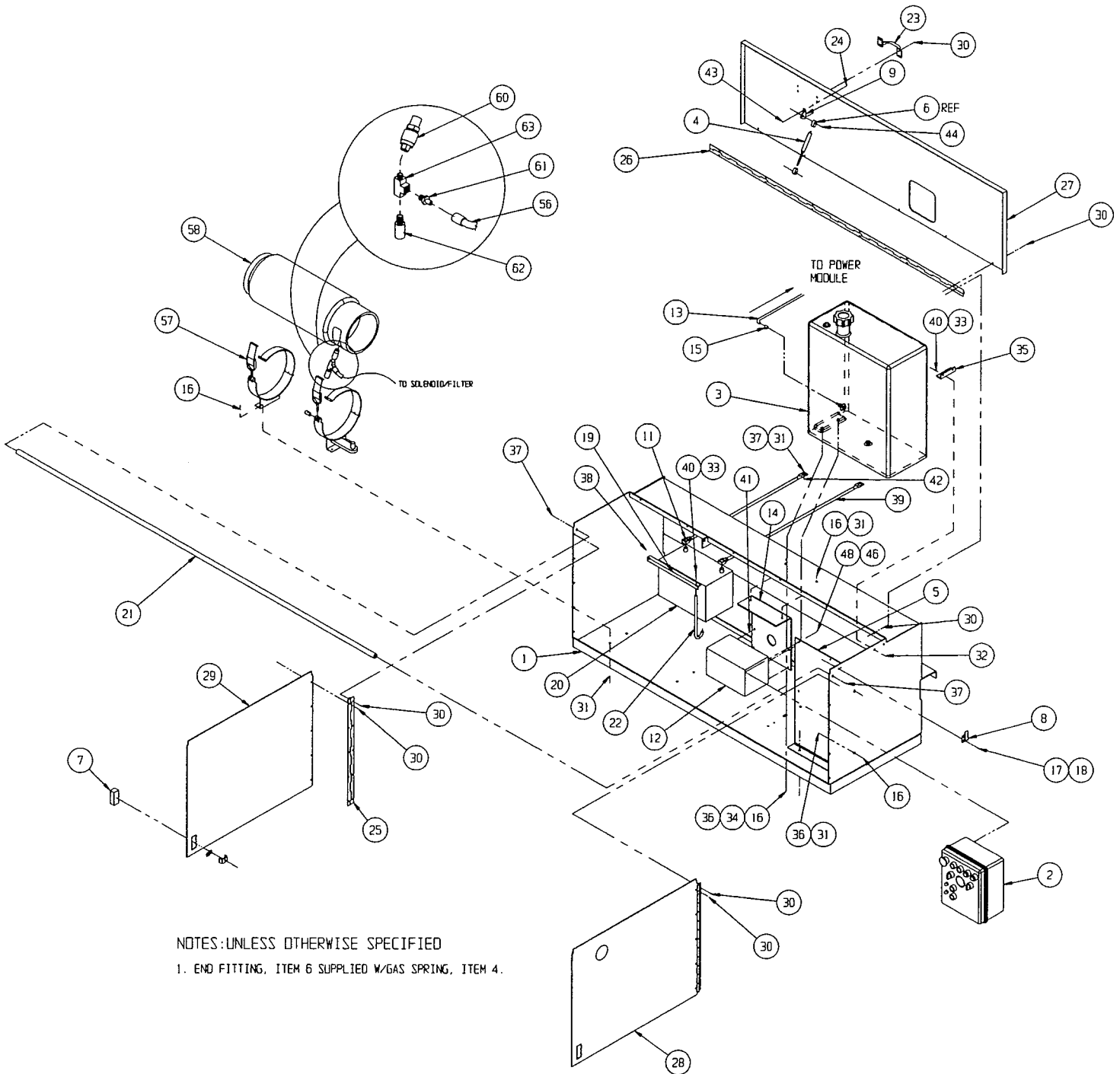

NOTES: UNLESS OTHERWISE SPECIFIED
1. END FITTING, ITEM 6 SUPPLIED W/GAS SPRING, ITEM 4.

ILLUSTRATED PARTS BREAKDOWN

**CONTROL MODULE ASSEMBLY, LX50
TWO-WHEEL DRIVE DIESEL, STANDARD DECK
067521-021**

ITEM	PART NO.	DESCRIPTION	QTY.
1	067810-003	CONTROL MODULE WELDMENT	1
2	067491-002	CONTROL BOX , DIESEL	1
3	067485-001	FUEL TANK ASSEMBLY, DIESEL	1
4	063650-012	GAS SPRING	1
5	067484-000	CONTROL BOX MOUNT	1
6	067648-008	END FITTING, GAS SPRING	REF
7	067629-000	LATCH, FLUSH LIFT & TURN	2
8	005299-000	LATCH, TOGGLE	2
9	067902-000	BRACKET, GAS SPRING	1
11	014435-001	TERMINAL, BATTERY	2
12	067489-000	VALVE BLOCK ASSY. (2 W.D.)	1
13	012739-099	HOSE, 1/4 I.D.	11 FT
14	067892-000	BRACKET, VALVE BLOCK	1
15	020541-001	HOSE CLAMP	2
16	011254-008	SCRW HHC GR5 3/8-16UNC X 1	10
17	011708-004	SCRW MACH RD HD 8-32UNC X 1/2	4
18	011248-002	LOCK NUT, ESMA 8-32UNC	4
19	064040-000	ANGLE, BATTERY HOLD DOWN	1
20	062299-002	BATTERY, 12 VDC GROUP-27C	1
21	067856-000	WELDMENT, STIFFENER	1
22	012039-000	ROD, BATTERY HOLD DOWN	2
23	025427-002	HANDLE	1
24	011253-008	SCR HHC 5/16-18 X 1	2
25	067808-000	HINGE, 1 1/2 X 23 7/8	2
26	067809-002	HINGE, 1 1/2 X 65	1

ITEM	PART NO.	DESCRIPTION	QTY.
27	067799-008	MODULE COVER / CONTROL	1
28	067800-000	MODULE DOOR, R.H.	1
29	067801-000	MODULE DOOR, L.H.	1
30	026554-002	POP RIVET, 1/4 DIA (.251-.375 GRIP)	36
31	011248-006	NUT, 3/8-16 ESNA	7
32	011252-006	SCREW, HHC 1/4-20 X 3/4	2
33	011248-004	NUT, 1/4-20 ESNA	4
34	011239-006	WASHER, 3/8", SPLIT LOCK	2
35	067854-001	ANGLE, FUEL TANK MOUNT	1
36	011240-006	WASHER, 3/8", STD, FLT	2
37	011254-006	SCREW HHC 3/8-16 X 3/4	2
38	012736-099	HOSE, 3/16 ID	11 FT
39	062125-002	CABLE, BATTERY X 69	2
40	011240-004	WASHER 1/4 FLAT	4
41	011254-004	SCRW HHC GR5 3/8-16UNC X 1/2	4
42	011237-006	WASHER, 3/8 STAR	1
43	011248-005	NUT, HEX 5/16-18 ESNA	2
44	015936-004	SCR, SHOULDER 3/8 DIA. X 1/2	2
45	011275-006	SCREW HHC 10-32UNF X 3/4"	4
46	011238-002	WASHER SPLIT-LOCK #10	4
47	067492-001	WIRE HARNESS, MAIN CONTROL	1
48	067492-002	WIRE HARNESS, VALVE BLOCK	1
49	029931-003	CONN. FEMALE PUSH, 16-14 AWG, .250 TAB	4
50	029458-099	WIRE 16 AWG, RED	6 IN.

**See page 6-67 for
wiring diagram**

ILLUSTRATED PARTS BREAKDOWN

Section 6.1

NOTES: UNLESS OTHERWISE SPECIFIED
1. END FITTING, ITEM 6 SUPPLIED W/GAS SPRING, ITEM 4.

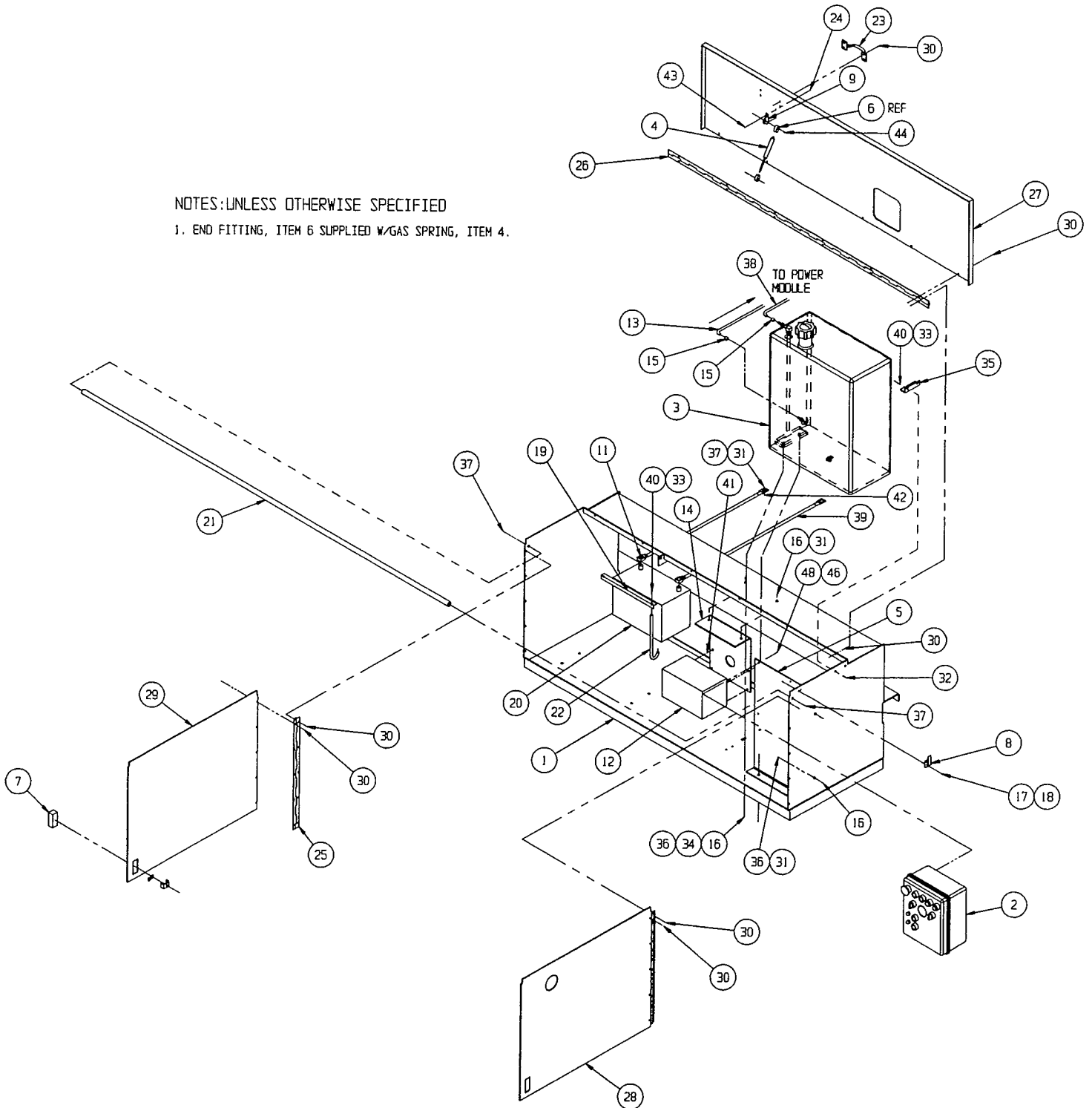

ILLUSTRATED PARTS BREAKDOWN

**CONTROL MODULE ASSEMBLY, LX50
FOUR-WHEEL DRIVE DUAL FUEL, STANDARD DECK
067521-022**

ITEM	PART NO.	DESCRIPTION	QTY.
1	067810-003	CONTROL MODULE WELDMENT	1
2	067491-001	CONTROL BOX , D/F	1
3	067485-000	FUEL TANK, ASSEMBLY, GAS	1
4	063650-012	GAS SPRING	1
5	067484-000	CONTROL BOX MOUNT	1
6	067648-008	END FITTING, GAS SPRING	REF
7	067629-000	LATCH, FLUSH LIFT & TURN	2
8	005299-000	LATCH, TOGGLE	2
9	067902-000	BRACKET, GAS SPRING	1
11	014435-001	TERMINAL, BATTERY	2
12	067489-001	VALVE BLOCK ASSY. (4WD)	1
13	012739-099	HOSE, 1/4 I.D.	11 FT
14	067892-000	BRACKET, VALVE BLOCK	1
15	020541-001	HOSE CLAMP	1
16	011254-008	SCRW HHC GR5 3/8-16UNC X 1	10
17	011708-004	SCRW MACH RD HD 8-32UNC X 1/2	4
18	011248-002	LOCK NUT, ESMA 8-32UNC	4
19	064040-000	ANGLE, BATTERY HOLD DOWN	1
20	062299-002	BATTERY, 12 VDC GROUP-27C	1
21	067856-000	WELDMENT, STIFFENER	1
22	012039-000	ROD, BATTERY HOLD DOWN	2
23	025427-002	HANDLE	1
24	011253-008	SCR HHC 5/16-18 X 1	2
25	067808-000	HINGE, 1 1/2 X 23 7/8	2
26	067809-002	HINGE, 1 1/2 X 65	1
27	067799-008	MODULE COVER / CONTROL	1
28	067800-000	MODULE DOOR, R.H.	1
29	067801-000	MODULE DOOR, L.H.	1

ITEM	PART NO.	DESCRIPTION	QTY.
30	026554-002	POP RIVET, 1/4 DIA (.251-.375 GRIP)	36
31	011248-006	NUT, 3/8-16 ESNA	7
32	011252-006	SCREW, HHC 1/4-20 X 3/4	2
33	011248-004	NUT, 1/4-20 ESNA	4
34	011239-006	WASHER, 3/8", SPLIT LOCK	2
35	067854-001	ANGLE, FUEL TANK MOUNT	1
36	011240-006	WASHER, 3/8", STD, FLT	2
37	011254-006	SCREW HHC 3/8-16 X 3/4	2
39	062125-002	CABLE, BATTERY X 69	2
40	011240-004	WASHER 1/4 FLAT	4
41	011254-004	SCRW HHC GR5 3/8-16UNC X 1/2	4
42	011237-006	WASHER, 3/8 STAR	1
43	011248-005	NUT, HEX 5/16-18 ESNA	2
44	015936-004	SCR, SHOULDER 3/8 DIA. X 1/2	2
45	011275-006	SCREW HHC 10-32UNF X 3/4"	4
46	011238-002	WASHER SPLIT-LOCK #10	4
47	067492-001	WIRE HARNESS, MAIN CONTROL	1
48	067492-002	WIRE HARNESS, VALVE BLOCK	1
56	067615-049	HOSE ASSY x 100"	1
57	027823-000	TANK MOUNTING BRACKET	1
58	027934-003	FUEL TANK. PROPANE	1
60		FEMALE ADAPTER (PROPANE TANK)	1
61	SUPPLIED WITH ENGINE	FITTING, STIR 2MP-6MJ BRASS	1
62		RELIEF VALVE 400 PSI	1
63		FITTING 2-2-2 STR TEE BRASS	1

**See page 6-66 for
wiring diagram**

ILLUSTRATED PARTS BREAKDOWN

Section 6.1

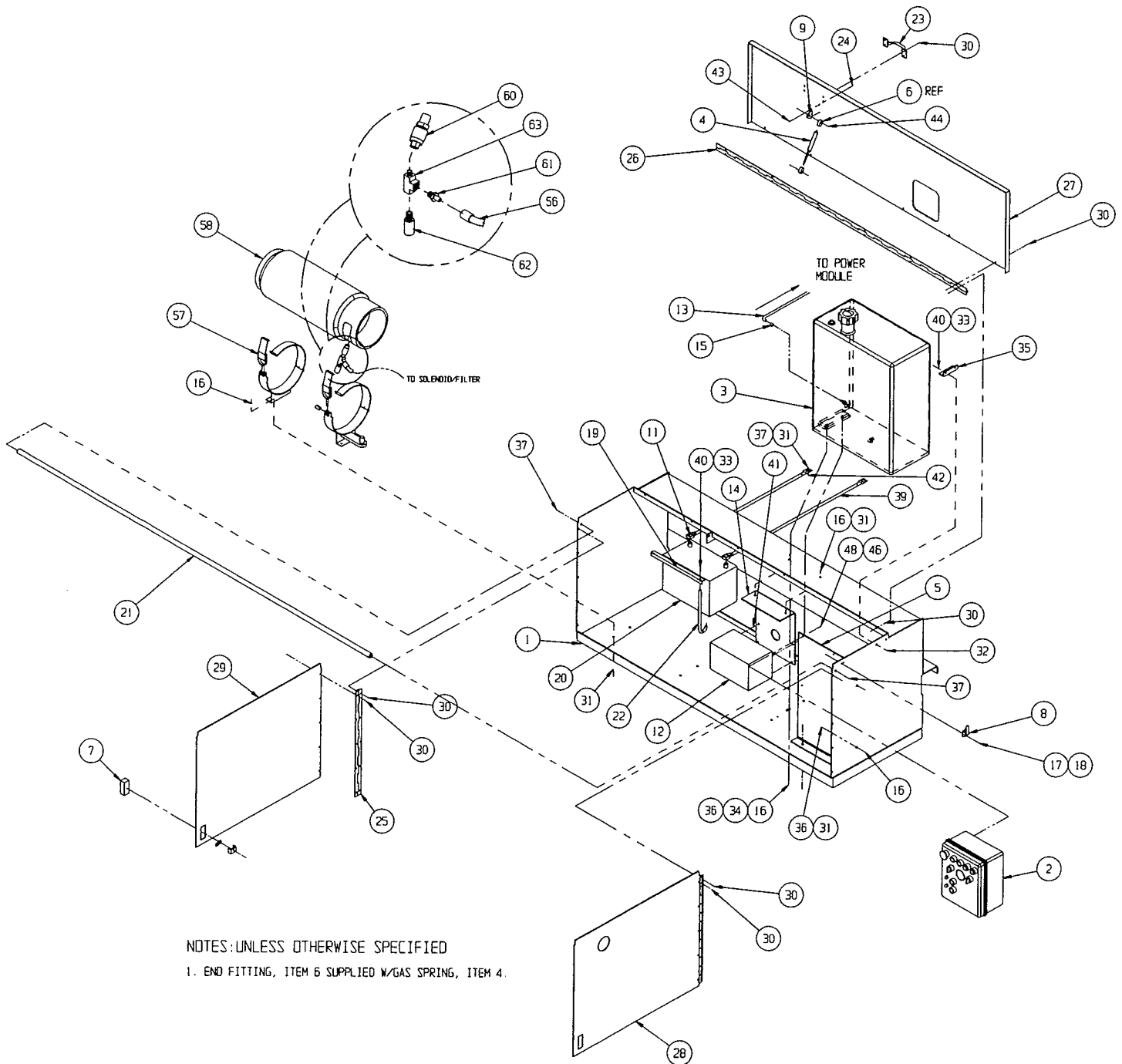

NOTES: UNLESS OTHERWISE SPECIFIED

1. END FITTING, ITEM 6 SUPPLIED W/ GAS SPRING, ITEM 4.

**Section
6.1**

ILLUSTRATED PARTS BREAKDOWN

**CONTROL MODULE ASSEMBLY, LX50
FOUR-WHEEL DRIVE DIESEL, STANDARD DECK
067521-023**

ITEM	PART NO.	DESCRIPTION	QTY.
1	067810-003	CONTROL MODULE WELDMNT	1
2	067491-002	CONTROL BOX , DIESEL	1
3	067485-001	FUEL TANK ASSEMBLY, DIESEL	1
4	063650-012	GAS SPRING	1
5	067484-000	CONTROL BOX MOUNT	1
6	067648-008	END FITTING, GAS SPRING	REF
7	067629-000	LATCH, FLUSH LIFT & TURN	2
8	05299-000	LATCH, TOGGLE	2
9	067902-000	BRACKET, GAS SPRING	1
11	014435-001	TERMINAL, BATTERY	2
12	067489-001	VALVE BLOCK ASSY. (4WD)	1
13	012739-099	HOSE, 1/4 I.D.	11 FT
14	067892-000	BRACKET, VALVE BLOCK	1
15	020541-001	HOSE CLAMP	2
16	011254-008	SCRW HHC GR5 3/8-16UNC X 1	10
17	011708-004	SCRW MACH RD HD 8-32UNC X 1/2	4
18	011248-002	LOCK NUT, ESMA 8-32UNC	4
19	064040-000	ANGLE, BATTERY HOLD DOWN	1
20	062299-002	BATTERY, 12 VDC GROUP-27C	1
21	067856-000	WELDMNT, STIFFENER	1
22	012039-000	ROD, BATTERY HOLD DOWN	2
23	025427-002	HANDLE	1
24	011253-008	SCR HHC 5/16-18 X 1	2
25	067808-000	HINGE, 1 1/2 X 23 7/8	2

ITEM	PART NO.	DESCRIPTION	QTY.
26	067809-002	HINGE, 1 1/2 X 65	1
27	067799-008	MODULE COVER / CONTROL	1
28	067800-000	MODULE DOOR, R.H.	1
29	067801-000	MODULE DOOR, L.H.	1
30	026554-002	POP RIVET, 1/4 DIA (.251-.375 GRIP)	36
31	011248-006	NUT, 3/8-16 ESNA	7
32	011252-006	SCREW, HHC 1/4-20 X 3/4	2
33	011248-004	NUT, 1/4-20 ESNA	4
34	011239-006	WASHER, 3/8", SPLIT LOCK	2
35	067854-001	ANGLE, FUEL TANK MOUNT	1
36	011240-006	WASHER, 3/8", STD, FLT	2
37	011254-006	SCREW HHC 3/8-16 X 3/4	2
38	012736-099	HOSE, 3/16 ID	11 FT
39	062125-002	CABLE, BATTERY X 69	2
40	011240-004	WASHER 1/4 FLAT	4
41	011254-004	SCRW HHC GR5 3/8-16UNC X 1/2	4
42	011237-006	WASHER, 3/8 STAR	1
43	011248-005	NUT, HEX 5/16-18 ESNA	2
44	015936-004	SCR, SHOULDER 3/8 DIA. X 1/2	2
45	011275-006	SCREW HHC 10-32UNF X 3/4"	4
46	011238-002	WASHER SPLIT-LOCK #10	4
47	067492-001	WIRE HARNESS, MAIN CONTROL	1
48	067492-002	WIRE HARNESS, VALVE BLOCK	1

**See page 6-67 for
wiring diagram**

ILLUSTRATED PARTS BREAKDOWN

Section 6.1

NOTES: UNLESS OTHERWISE SPECIFIED
1. END FITTING, ITEM 6 SUPPLIED W/GAS SPRING, ITEM 4.

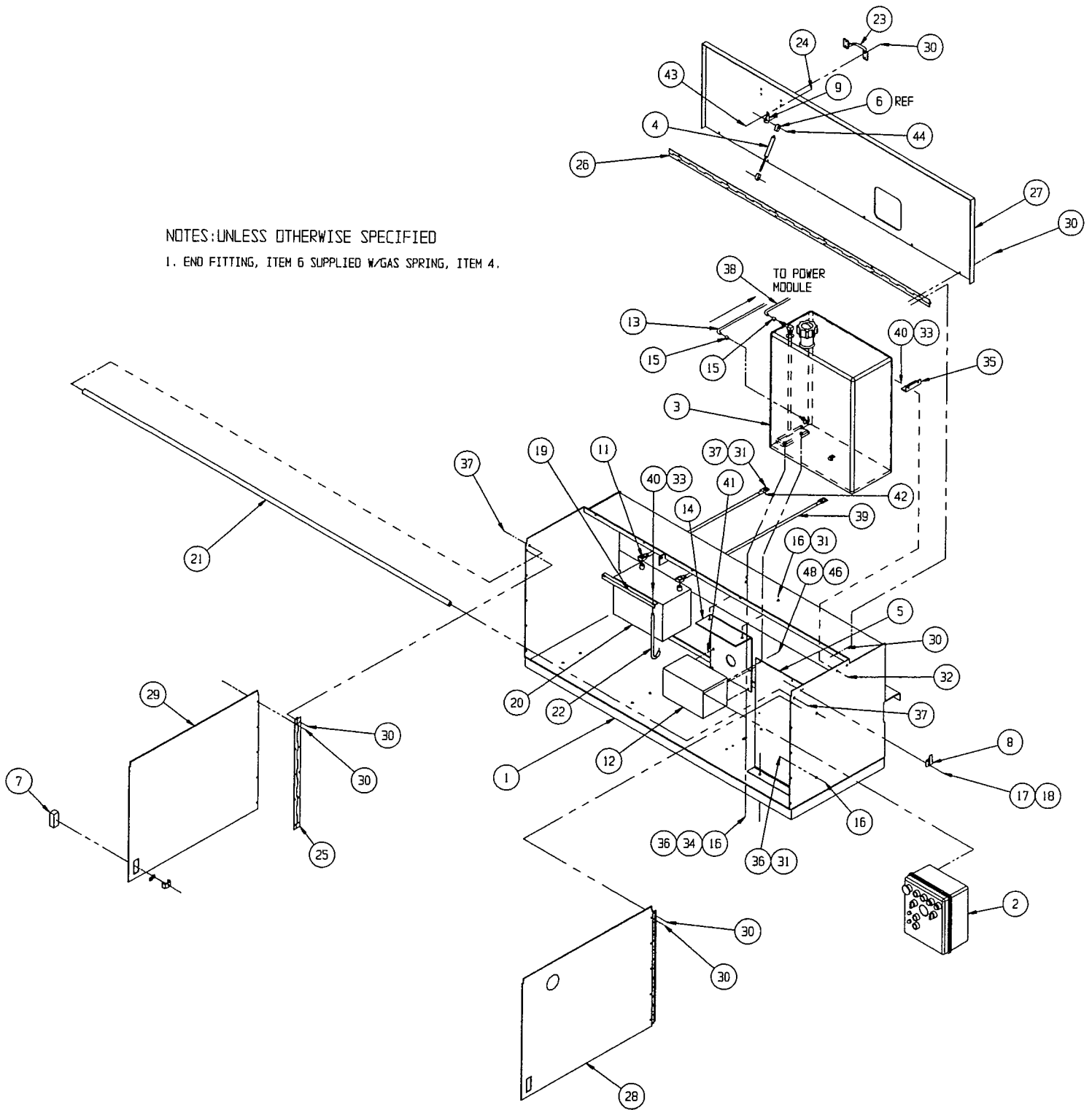

ILLUSTRATED PARTS BREAKDOWN

**CONTROL MODULE ASSEMBLY, LX50
TWO-WHEEL DRIVE DUAL FUEL, DUAL DECK
067521-028**

ITEM	PART NO.	DESCRIPTION	QTY.
1	067810-003	CONTROL MODULE WELDMENT	1
2	067491-003	CONTROL BOX , D/F, W/OUTRIGGER	1
3	067485-000	FUEL TANK, ASSEMBLY, GAS	1
4	063650-012	GAS SPRING	1
5	067484-000	CONTROL BOX MOUNT	1
6	067648-008	END FITTING, GAS SPRING	REF
7	067629-000	LATCH, FLUSH LIFT & TURN	2
8	05299-000	LATCH, TOGGLE	2
9	067902-000	BRACKET, GAS SPRING	1
11	014435-001	TERMINAL, BATTERY	2
12	067489-000	VALVE BLOCK ASSY. (2 W.D.)	1
13	012739-099	HOSE, 1/4 I.D.	11 FT
14	067892-000	BRACKET, VALVE BLOCK	1
15	020541-001	HOSE CLAMP	1
16	011254-008	SCRW HHC GR5 3/8-16UNC X 1	14
17	011708-004	SCRW MACH RD HD 8-32UNC X 1/2	4
18	011248-002	LOCK NUT, ESMA 8-32UNC	4
19	064040-000	ANGLE, BATTERY HOLD DOWN	1
20	062299-002	BATTERY, 12 VDC GROUP-27C	1
21	067856-000	WELDMENT, STIFFENER	1
22	012039-000	ROD, BATTERY HOLD DOWN	2
23	025427-002	HANDLE	1
24	011253-008	SCR HHC 5/16-18 X 1	2
25	067808-000	HINGE, 1 1/2 X 23 7/8	2
26	067809-002	HINGE, 1 1/2 X 65	1
27	067799-008	MODULE COVER / CONTROL	1
28	030841-031	MODULE DOOR, R.H.	1
29	030841-032	MODULE DOOR, L.H.	1
30	026554-002	POP RIVET, 1/4 DIA (.251-.375 GRIP)	36
31	011248-006	NUT, 3/8-16 ESNA	11

ITEM	PART NO.	DESCRIPTION	QTY.
32	011252-006	SCREW, HHC 1/4-20 X 3/4	2
33	011248-004	NUT, 1/4-20 ESNA	6
34	011239-006	WASHER, 3/8", SPLIT LOCK	2
35	067854-001	ANGLE, FUEL TANK MOUNT	1
36	011240-006	WASHER, 3/8", STD, FLT	2
37	011254-006	SCREW HHC 3/8-16 X 3/4	2
39	062125-002	CABLE, BATTERY X 69	2
40	011240-004	WASHER 1/4 FLAT-16UNC X 1/2	4
41	011254-004	SCRW HHC GR5 3/8-16UNC X 1/2	4
42	011237-006	WASHER, 3/8 STAR	1
43	011248-005	NUT, HEX 5/16-18 ESNA	2
44	015936-004	SCR, SHOULDER 3/8 DIA. X 1/2	2
45	030841-030	WELDMENT, STAIR	1
46	067490-000	VALVE BLOCK, OUTRIGGER CONTROL	1
47	011252-032	SCREW HHC 1/4-20UNC X 4"	2
48	011275-006	SCREW HHC 10-32UNF X 3/4"	4
49	011238-002	WASHER SPLIT-LOCK #10	4
50	067492-001	WIRE HARNESS, MAIN CONTROL	1
51	067492-002	WIRE HARNESS, VALVE BLOCK	1
52	029931-003	CONN. FEMALE PUSH, 16-14 AWG, .250 TAB	2
53	029458-099	WIRE 16 AWG, RED	3 IN.
54	020733-005	TEE 12FJ-12MJ-12MJ	2
55	014693-003	ADAPTER, 12FJ-6MJ	2
56	067615-049	HOSE ASSY X 100"	1
57	027823-000	TANK MOUNTING BRACKET	1
58	027934-009	FUEL TANK, PROPANE	1
60		FEMALE ADAPTER (PROPANE TANK)	1
61	Supplied with engine	FITTING,STR 2MP-6MJ BRASS	1
62		RELIEF VALVE 400 PSI	1
63		FITTING 2-2-2 STR TEE BRASS	1

**See page 6-68 for
wiring diagram**

ILLUSTRATED PARTS BREAKDOWN

Section 6.1

NOTES: UNLESS OTHERWISE SPECIFIED

1: END FITTING, ITEM 6 SUPPLIED W/GAS SPRING, ITEM 4.

 ITEMS 54 AND 55 SCREW ONTO ADAPTERS IN PORTS 1 AND 16 OF VALVE BLOCK.

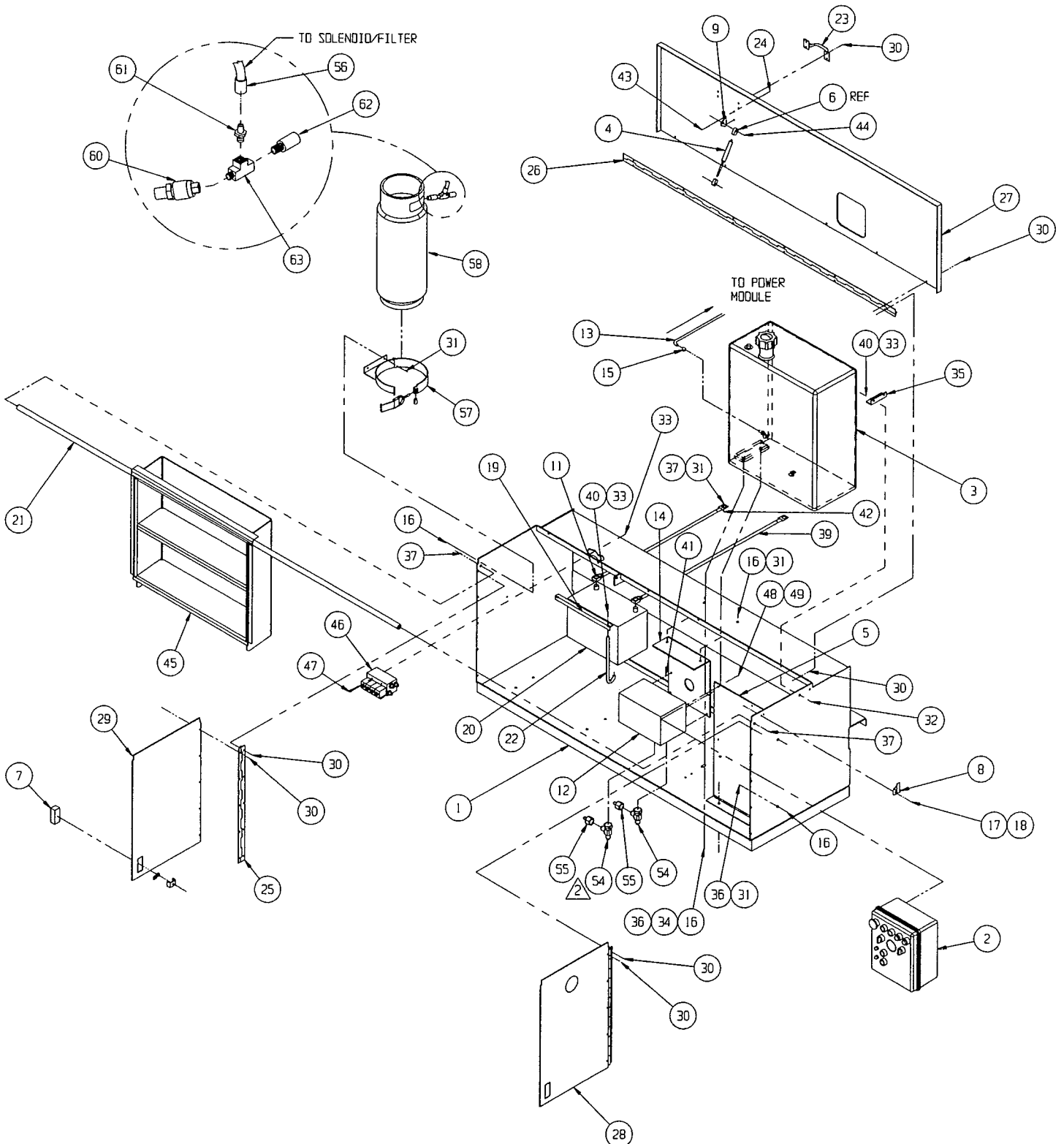

**Section
6.1**

ILLUSTRATED PARTS BREAKDOWN

**CONTROL MODULE ASSEMBLY, LX50
TWO-WHEEL DRIVE DIESEL, DUAL DECK
067521-029**

ITEM	PART NO.	DESCRIPTION	QTY.
1	067810-003	CONTROL MODULE WELDMENT	1
2	067491-004	CONTROL BOX , DIESEL, W/OUTRIGGER	1
3	067485-001	FUEL TANK, ASSEMBLY, DIESEL	1
4	063650-012	GAS SPRING	1
5	067484-000	CONTROL BOX MOUNT	1
6	067648-008	END FITTING, GAS SPRING	REF
7	067629-000	LATCH, FLUSH LIFT & TURN	2
8	05299-000	LATCH, TOGGLE	2
9	067902-000	BRACKET, GAS SPRING	1
11	014435-001	TERMINAL, BATTERY	2
12	067489-000	VALVE BLOCK ASSY. (2 W.D.)	1
13	012739-099	HOSE, 1/4 I.D.	11 FT
14	067892-000	BRACKET, VALVE BLOCK	1
15	020541-001	HOSE CLAMP	2
16	011254-008	SCRW HHC GR5 3/8-16UNC X 1	10
17	011708-004	SCRW MACH RD HD 8-32UNC X 1/2	4
18	011248-002	LOCK NUT, ESMA 8-32UNC	4
19	064040-000	ANGLE, BATTERY HOLD DOWN	1
20	062299-002	BATTERY, 12 VDC GROUP-27C	1
21	067856-000	WELDMENT, STIFFENER	1
22	012039-000	ROD, BATTERY HOLD DOWN	2
23	025427-002	HANDLE	1
24	011253-008	SCR HHC 5/16-18 X 1	2
25	067808-000	HINGE, 1 1/2 X 23 7/8	2
26	067809-002	HINGE, 1 1/2 X 65	1
27	067799-008	MODULE COVER / CONTROL	1
28	030841-031	MODULE DOOR, R.H.	1

ITEM	PART NO.	DESCRIPTION	QTY.
29	030841-032	MODULE DOOR, L.H.	1
30	026554-002	POP RIVET, 1/4 DIA (.251-.375 GRIP)	36
31	011248-006	NUT, 3/8-16 ESNA	7
32	011252-006	SCREW, HHC 1/4-20 X 3/4	2
33	011248-004	NUT, 1/4-20 ESNA	6
34	011239-006	WASHER, 3/8", SPLIT LOCK	2
35	067854-001	ANGLE, FUEL TANK MOUNT	1
36	011240-006	WASHER, 3/8", STD, FLT	2
37	011254-006	SCREW HHC 3/8-16 X 3/4	2
38	012736-099	HOSE, 3/16 ID	11 FT
39	062125-002	CABLE, BATTERY X 69	2
40	011240-004	WASHER 1/4 FLAT	4
41	011254-004	SCRW HHC GR5 3/8-16UNC X 1/2	4
42	011237-006	WASHER, 3/8 STAR	1
43	011248-005	NUT, HEX 5/16-18 ESNA	2
44	015936-004	SCR, SHOULDER 3/8 DIA. X 1/2	2
45	030841-030	WELDMENT, STAIR	1
46	067490-000	VALVE BLOCK, OUTRIGGER CONTROL	1
47	011252-032	SCREW HHC 1/4-20UNC X 4"	2
48	011275-006	SCREW HHC 10-32UNF X 3/4"	4
49	011238-002	WASHER SPLIT-LOCK #10	4
50	067492-001	WIRE HARNESS, MAIN CONTROL	1
51	067492-002	WIRE HARNESS, VALVE BLOCK	1
52	029931-003	CONN. FEMALE PUSH, 16-14 AWG, .250 TAB	2
53	029458-099	WIRE 16 AWG, RED	3 IN.
54	020733-005	TEE 12FJ-12MJ-12MJ	2
55	014693-003	ADAPTER, 12FJ-6MJ	2

**See page 6-68 for
wiring diagram**

ILLUSTRATED PARTS BREAKDOWN

Section 6.1

NOTES: UNLESS OTHERWISE SPECIFIED

1. END FITTING, ITEM 6 SUPPLIED W/GAS SPRING, ITEM 4.

2. ITEMS 54 AND 55 SCREW ONTO ADAPTERS IN PORTS 1 AND 16 OF VALVE BLOCK.

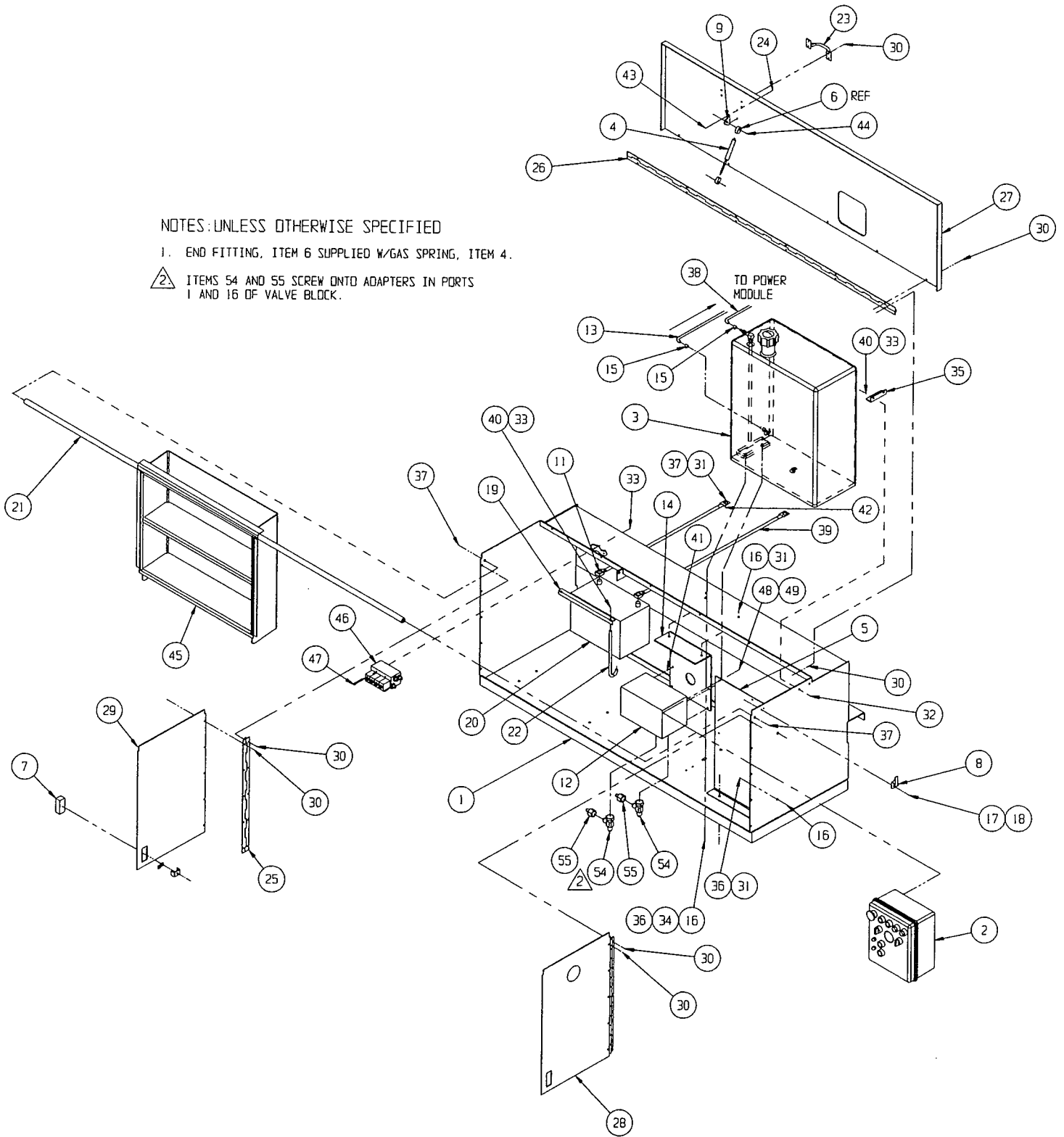

**Section
6.1**

ILLUSTRATED PARTS BREAKDOWN

**CONTROL MODULE ASSEMBLY, LX50
FOUR-WHEEL DRIVE DUAL FUEL, DUAL DECK
067521-030**

ITEM	PART NO.	DESCRIPTION	QTY.
1	067810-003	CONTROL MODULE WELDMENT	1
2	067491-003	CONTROL BOX , D/F, W/OUTRIGGER	1
3	067485-000	FUEL TANK, ASSEMBLY, GAS	1
4	063650-012	GAS SPRING	1
5	067484-000	CONTROL BOX MOUNT	1
6	067648-008	END FITTING, GAS SPRING	REF
7	067629-000	LATCH, FLUSH LIFT & TURN	2
8	05299-000	LATCH, TOGGLE	2
9	067902-000	BRACKET, GAS SPRING	1
11	014435-001	TERMINAL, BATTERY	2
12	067489-001	VALVE BLOCK ASSY. (4 W.D.)	1
13	012739-099	HOSE, 1/4 I.D.	11 FT
14	067892-000	BRACKET, VALVE BLOCK	1
15	020541-001	HOSE CLAMP	1
16	011254-008	SCRW HHC GR5 3/8-16UNC X 1	14
17	011708-004	SCRW MACH RD HD 8-32UNC X 1/2	4
18	011248-002	LOCK NUT, ESMA 8-32UNC	4
19	064040-000	ANGLE, BATTERY HOLD DOWN	1
20	062299-002	BATTERY, 12 VDC GROUP-27C	1
21	067856-000	WELDMENT, STIFFENER	1
22	012039-000	ROD, BATTERY HOLD DOWN	2
23	025427-002	HANDLE	1
24	011253-008	SCR HHC 5/16-18 X 1	2
25	067808-000	HINGE, 1 1/2 X 23 7/8	2
26	067809-002	HINGE, 1 1/2 X 65	1
27	067799-008	MODULE COVER / CONTROL	1
28	030841-031	MODULE DOOR, R.H.	1
29	030841-032	MODULE DOOR, L.H.	1
30	026554-002	POP RIVET, 1/4 DIA (.251-.375 GRIP)	36

ITEM	PART NO.	DESCRIPTION	QTY.
31	011248-006	NUT, 3/8-16 ESNA	11
32	011252-006	SCREW, HHC 1/4-20 X 3/4	2
33	011248-004	NUT, 1/4-20 ESNA	6
34	011239-006	WASHER, 3/8", SPLIT LOCK	2
35	067854-001	ANGLE, FUEL TANK MOUNT	1
36	011240-006	WASHER, 3/8", STD, FLT	2
37	011254-006	SCREW HHC 3/8-16 X 3/4	2
39	062125-002	CABLE, BATTERY X 69	2
40	011240-004	WASHER 1/4 FLAT	4
41	011254-004	SCRW HHC GR5 3/8-16UNC X 1/2	4
42	011237-006	WASHER, 3/8 STAR	1
43	011248-005	NUT, HEX 5/16-18 ESNA	2
44	015936-004	SCR, SHOULDER 3/8 DIA. X 1/2	2
45	030841-030	WELDMENT, STAIR	1
46	067490-000	VALVE BLOCK, OUTRIGGER CONTROL	1
47	011252-032	SCREW HHC 1/4-20UNC X 4"	2
48	011275-006	SCREW HHC 10-32UNF X 3/4"	4
49	011238-002	WASHER SPLIT-LOCK #10	4
50	067492-001	WIRE HARNESS, MAIN CONTROL	1
51	067492-002	WIRE HARNESS, VALVE BLOCK	1
52	020733-005	TEE 12FJ-12MJ-12MJ	2
53	014693-003	ADAPTER, 12FJ-6MJ	2
56	067615-049	HOSE ASSY X 100"	1
57	027823-000	TANK MOUNTING BRACKET	1
58	027934-009	FUEL TANK, PROPANE	1
60		FEMALE ADAPTER (PROPANE TANK)	1
61	Supplied with engine	FITTING,STR 2MP-6MJ BRASS	1
62		RELIEF VALVE 400 PSI	1
63		FITTING 2-2-2 STR TEE BRASS	1

**See page 6-69 for
wiring diagram**

ILLUSTRATED PARTS BREAKDOWN

Section 6.1

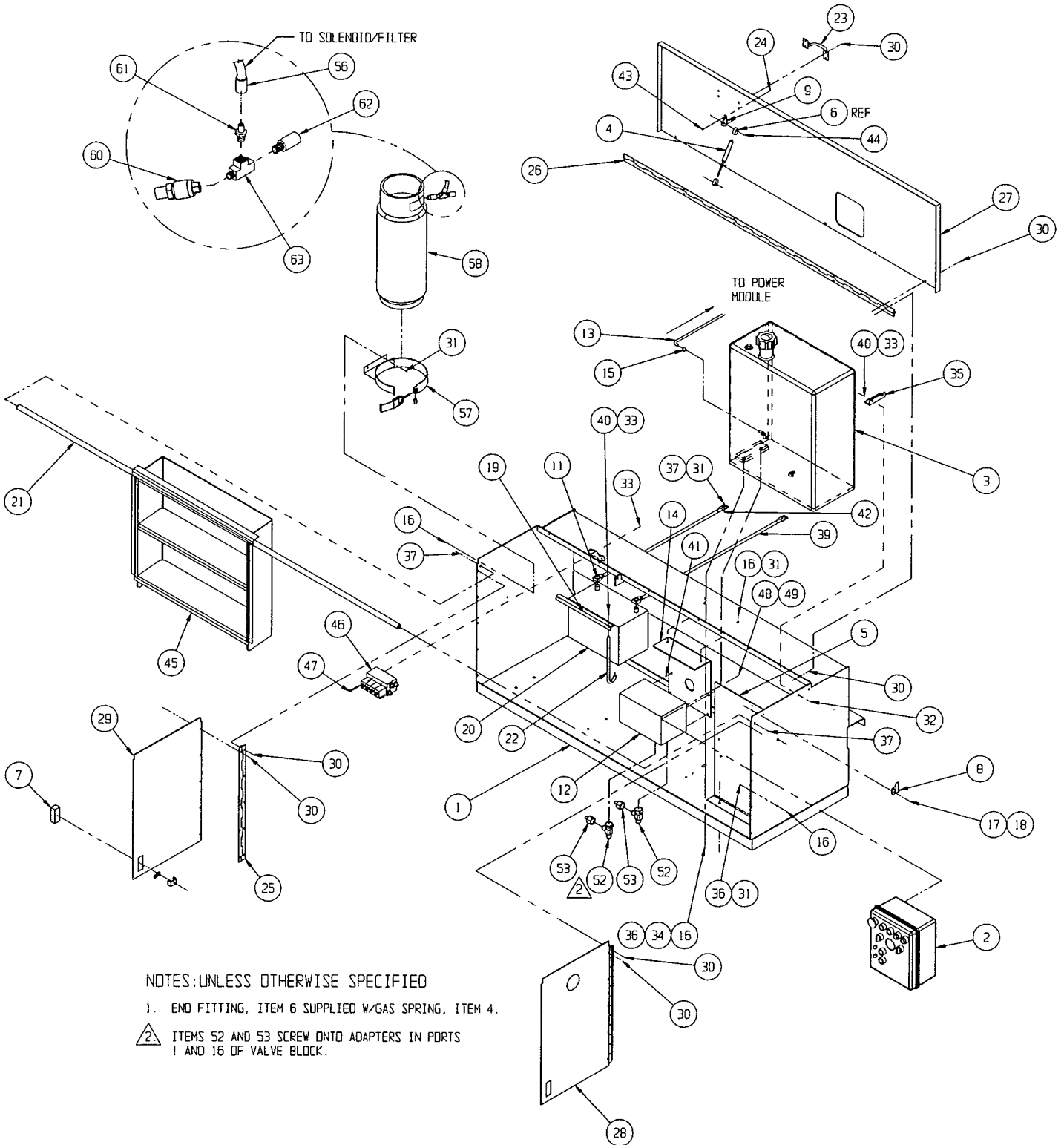

**Section
6.1**

ILLUSTRATED PARTS BREAKDOWN

**CONTROL MODULE ASSEMBLY, LX50
FOUR-WHEEL DRIVE DIESEL, DUAL DECK
067521-031**

ITEM	PART NO.	DESCRIPTION	QTY.
1	067810-003	CONTROL MODULE WELDMENT	1
2	067491-004	CONTROL BOX , DIESEL, W/OUTRIGGER	1
3	067485-001	FUEL TANK, ASSEMBLY, DIESEL	1
4	063650-012	GAS SPRING	1
5	067484-000	CONTROL BOX MOUNT	1
6	067648-008	END FITTING, GAS SPRING	REF
7	067629-000	LATCH, FLUSH LIFT & TURN	2
8	05299-000	LATCH, TOGGLE	2
9	067902-000	BRACKET, GAS SPRING	1
11	014435-001	TERMINAL, BATTERY	2
12	067489-001	VALVE BLOCK ASSY. (4 W.D.)	1
13	012739-099	HOSE, 1/4 I.D.	11 FT
14	067892-000	BRACKET, VALVE BLOCK	1
15	020541-001	HOSE CLAMP	2
16	011254-008	SCRW HHC GR5 3/8-16UNC X 1	10
17	011708-004	SCRW MACH RD HD 8-32UNC X 1/2	4
18	011248-002	LOCK NUT, ESMA 8-32UNC	4
19	064040-000	ANGLE, BATTERY HOLD DOWN	1
20	062299-002	BATTERY, 12 VDC GROUP-27C	1
21	067856-000	WELDMENT, STIFFENER	1
22	012039-000	ROD, BATTERY HOLD DOWN	2
23	025427-002	HANDLE	1
24	011253-008	SCR HHC 5/16-18 X 1	2
25	067808-000	HINGE, 1 1/2 X 23 7/8	2
26	067809-002	HINGE, 1 1/2 X 65	1
27	067799-008	MODULE COVER / CONTROL	1

ITEM	PART NO.	DESCRIPTION	QTY.
28	030841-031	MODULE DOOR, R.H.	1
29	030841-032	MODULE DOOR, L.H.	1
30	026554-002	POP RIVET, 1/4 DIA (.251-.375 GRIP)	36
31	011248-006	NUT, 3/8-16 ESNA	7
32	011252-006	SCREW, HHC 1/4-20 X 3/4	2
33	011248-004	NUT, 1/4-20 ESNA	6
34	011239-006	WASHER, 3/8", SPLIT LOCK	2
35	067854-001	ANGLE, FUEL TANK MOUNT	1
36	011240-006	WASHER, 3/8", STD, FLT	2
37	011254-006	SCREW HHC 3/8-16 X 3/4	2
38	012736-099	HOSE, 3/16 ID	11 FT
39	062125-002	CABLE, BATTERY X 69	2
40	011240-004	WASHER 1/4 FLAT	4
41	011254-004	SCRW HHC GR5 3/8-16UNC X 1/2	4
42	011237-006	WASHER, 3/8 STAR	1
43	011248-005	NUT, HEX 5/16-18 ESNA	2
44	015936-004	SCR, SHOULDER 3/8 DIA. X 1/2	2
45	030841-030	WELDMENT, STAIR	1
46	067490-000	VALVE BLOCK, OUTRIGGER CONTROL	1
47	011252-032	SCREW HHC 1/4-20UNC X 4"	2
48	011275-006	SCREW HHC 10-32UNF X 3/4"	4
49	011238-002	WASHER SPLIT-LOCK #10	4
50	067492-001	WIRE HARNESS, MAIN CONTROL	1
51	067492-002	WIRE HARNESS, VALVE BLOCK	1
52	020733-005	TEE 12FJ-12MJ-12MJ	2
53	014693-003	ADAPTER, 12FJ-6MJ	2

**See page 6-69 for
wiring diagram**

ILLUSTRATED PARTS BREAKDOWN

Section 6.1

NOTES: UNLESS OTHERWISE SPECIFIED

1. END FITTING, ITEM 6 SUPPLIED W/GAS SPRING, ITEM 4.

2. ITEMS 52 AND 53 SCREW ONTO ADAPTERS IN PORTS 1 AND 16 OF VALVE BLOCK.

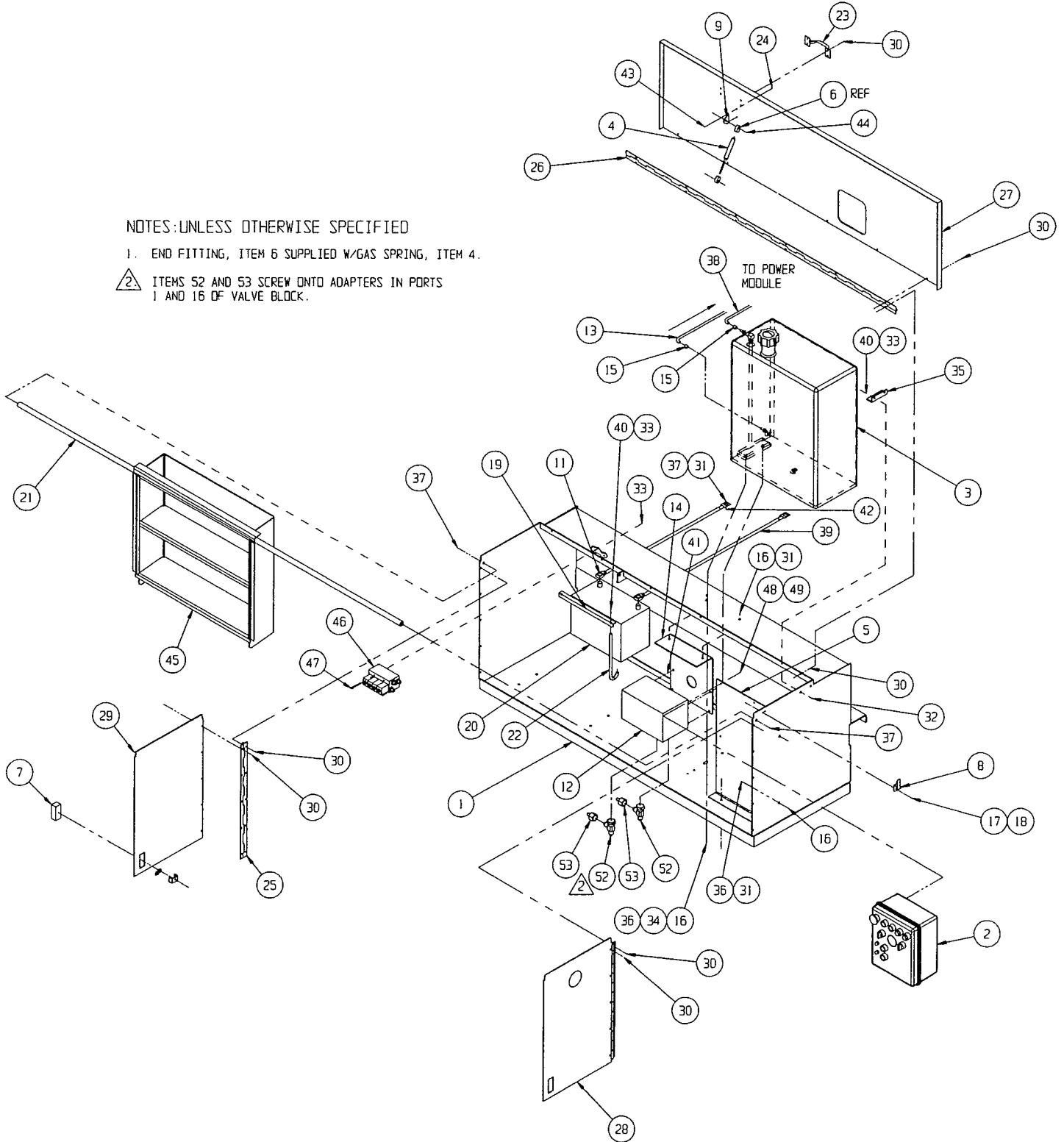

ILLUSTRATED PARTS BREAKDOWN

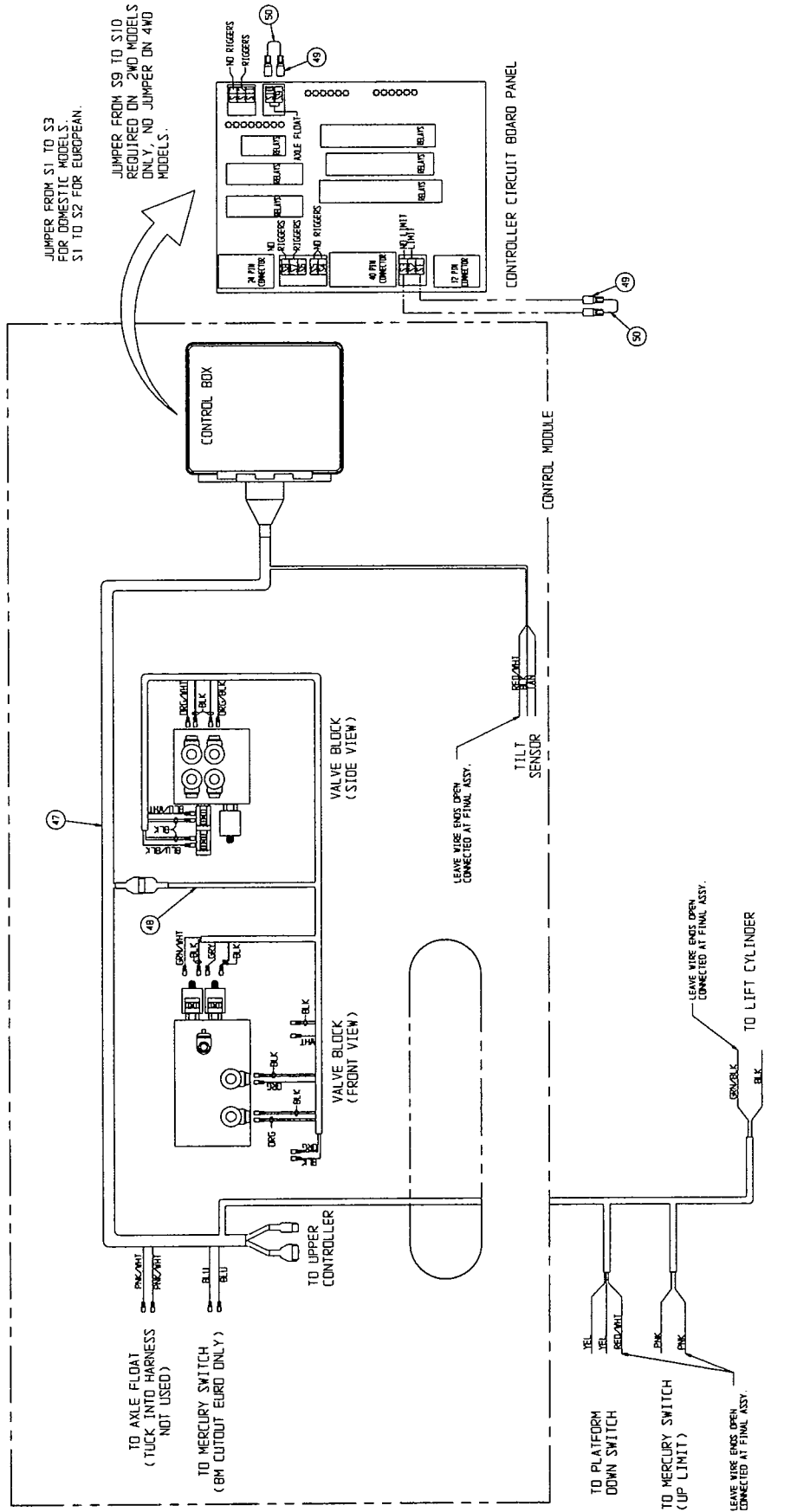

WIRING DIAGRAM - TWO WHEEL DRIVE, STANDARD DECK

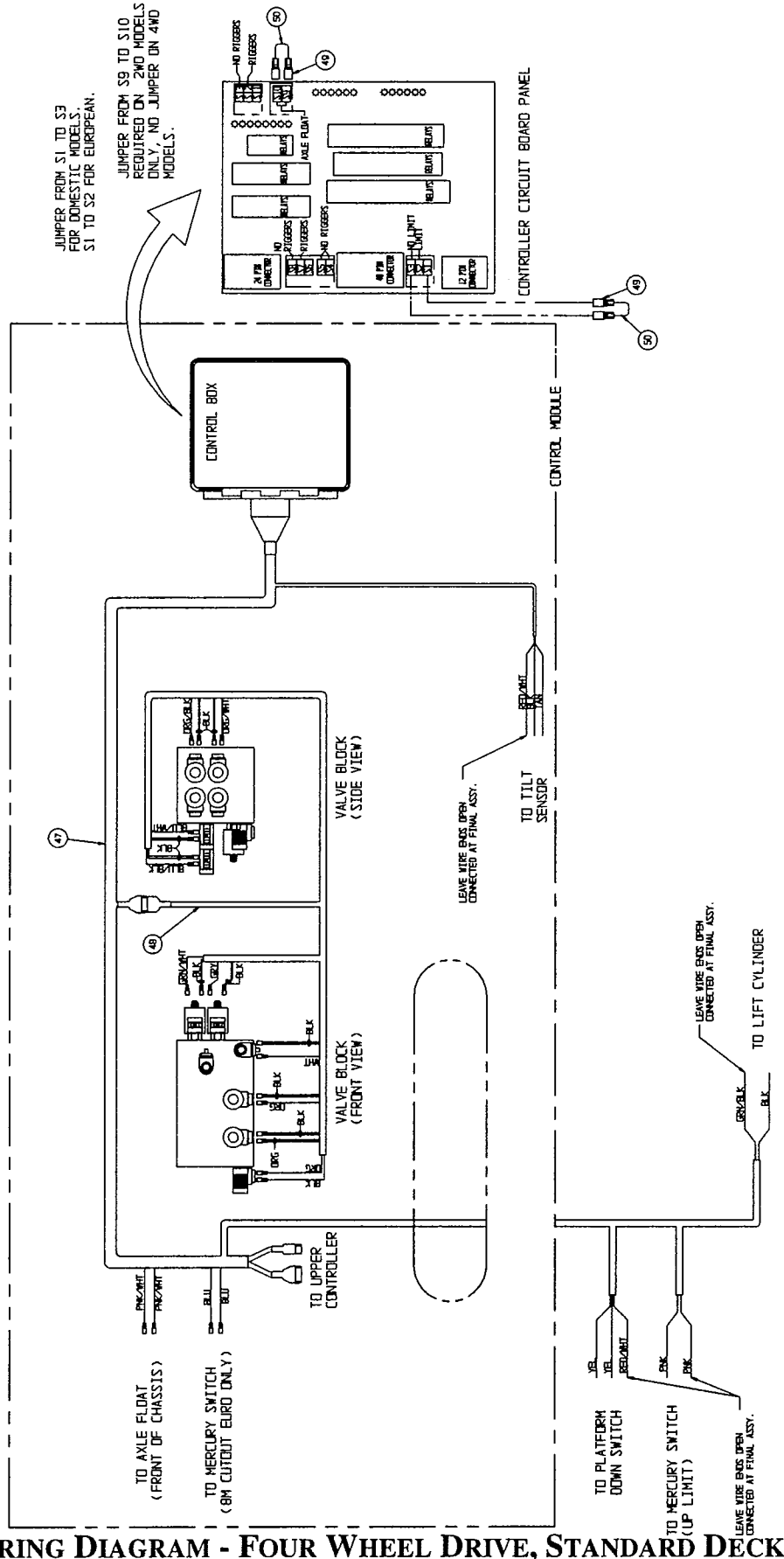

WIRING DIAGRAM - FOUR WHEEL DRIVE, STANDARD DECK

ILLUSTRATED PARTS BREAKDOWN

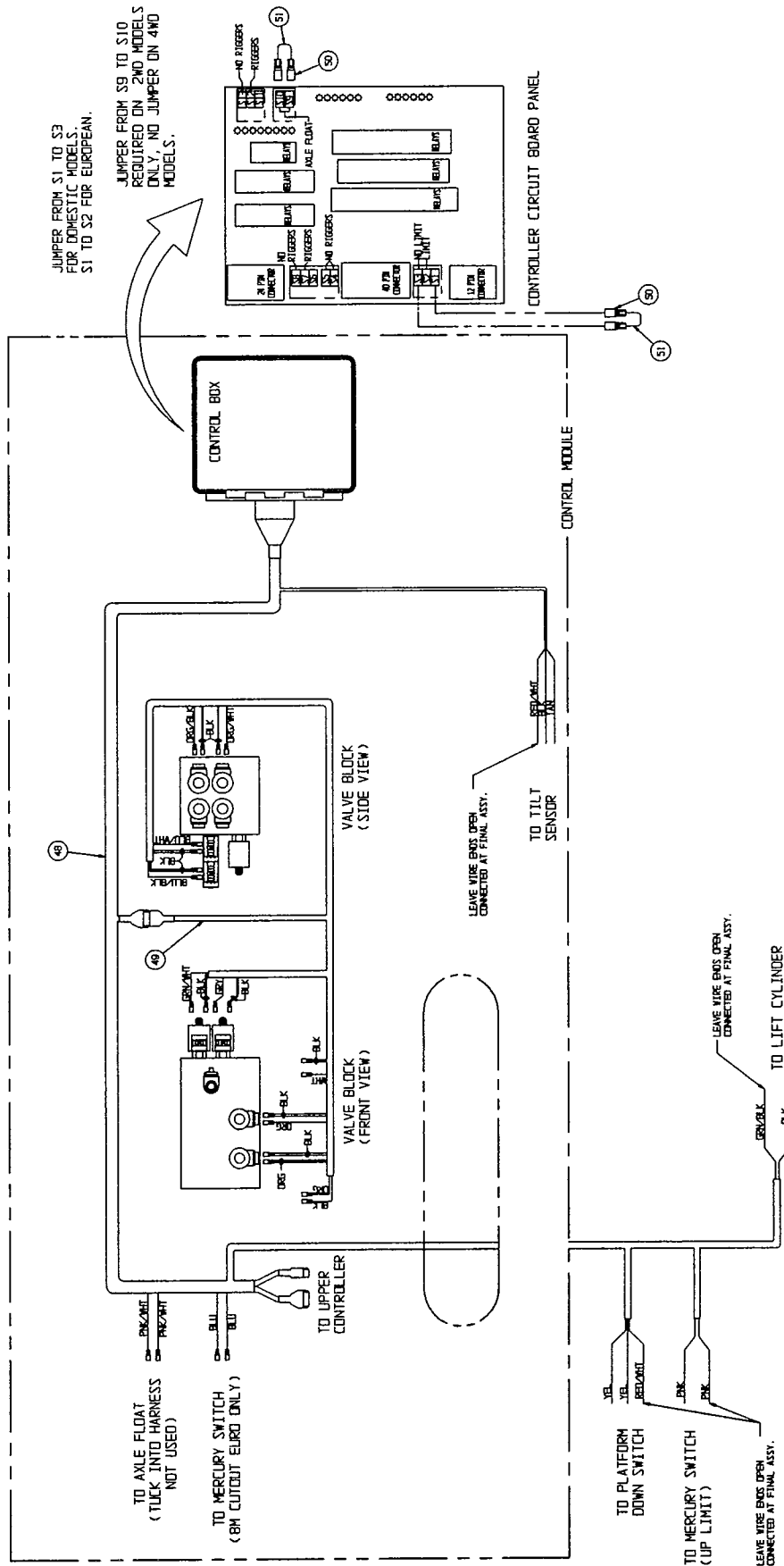

WIRING DIAGRAM - TWO WHEEL DRIVE, DUAL DECK

ILLUSTRATED PARTS BREAKDOWN

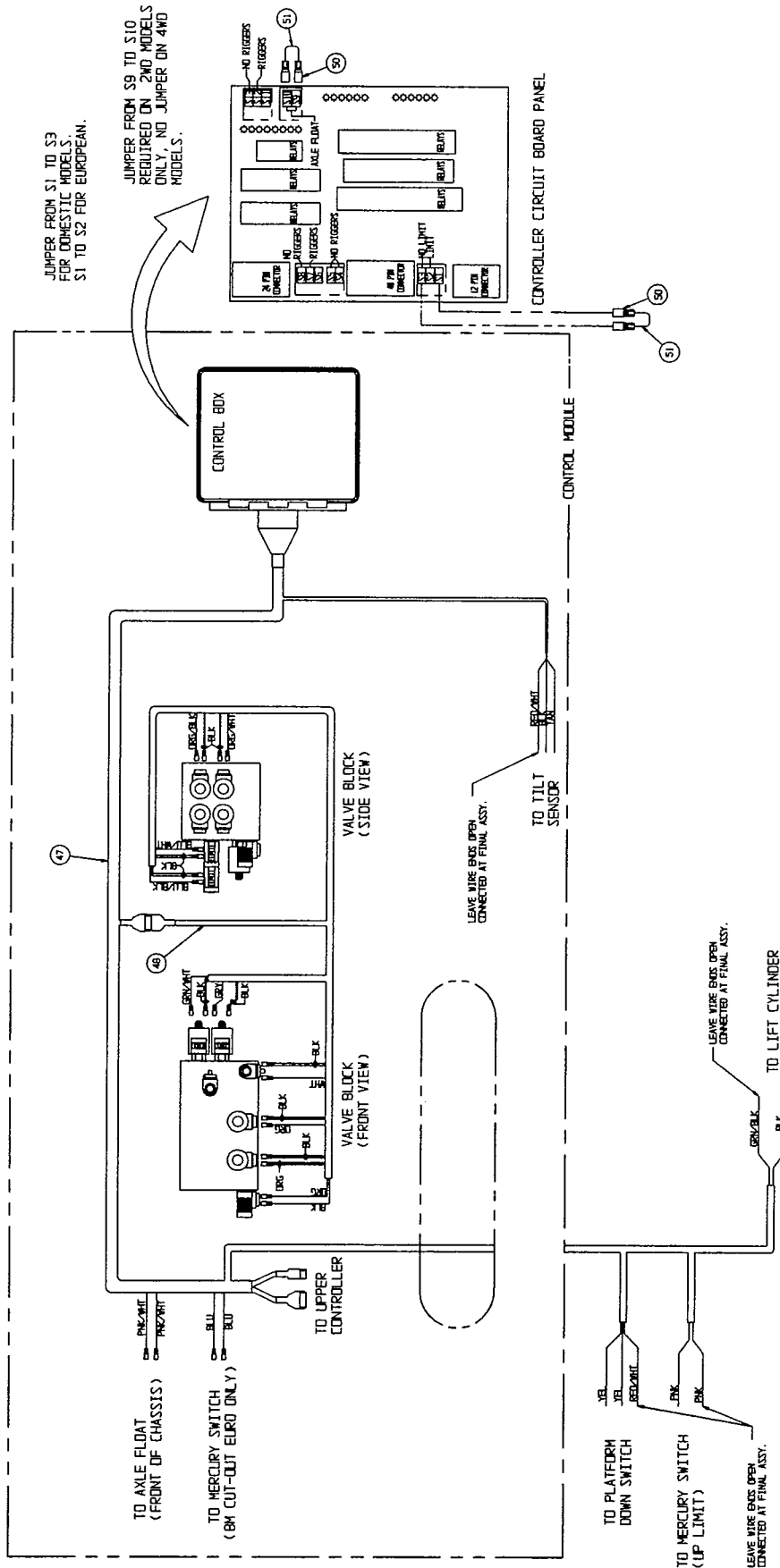

WIRING DIAGRAM - FOUR WHEEL DRIVE, DUAL DECK

**Section
6.1**

ILLUSTRATED PARTS BREAKDOWN

**CONTROL CABLE ASSEMBLY,
LX50
067536-012**

ITEM	PART NO.	DESCRIPTION	QTY.
1	067645-099	CABLE, 16/6, 18/12 MULTICONDUCTOR	90 FT
2	029601-013	CONN RING TERM 16-14 GA #10	2
3	063956-002	PIN, CONTACT MALE 20-14 GA	8
4	029610-002	CONN FORK TERM 16-14 GA #8	6
5	029457-099	WIRE, 16GA GRN X 12 IN	1 FT
6	029620-002	CONN, BUTT 16-14GA	4
7	029616-001	CONN, FEMALE PUSH 16-14GA X .188	2
8	029483-099	WIRE 16 GA RD/WHT X 14 IN	1.2 FT
9	068760-001	DT CONNECTOR, RECEPTACLE, # DT04-12P	1
10	067990-001	DT CONNECTOR, RECEPTACLE, # DT04 6P	1
11	068761-000	LOCKING WEDGE, RECEPTACLE, # W12P	1
12	067990-003	LOCKING WEDGE, RECEPTACLE, # W6P	1
13	015790-004	CONTACT PIN, 16-18 AWG	18
14	068908-001	BOOT ELECT. RECEPTACLE, # DT-12-P-BT	1
15	068908-002	BOOT ELECT. RECEPTACLE, # DT-6-P-BT	1
16	029825-002	DIODE, 5 AMP, 400 V.	1

ILLUSTRATED PARTS BREAKDOWN

Section 6.1

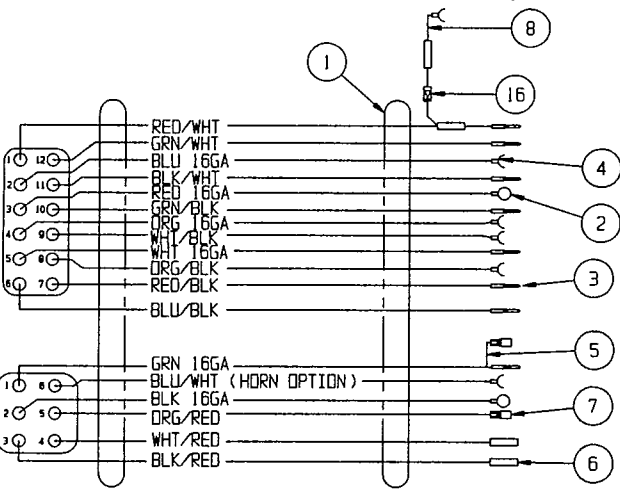
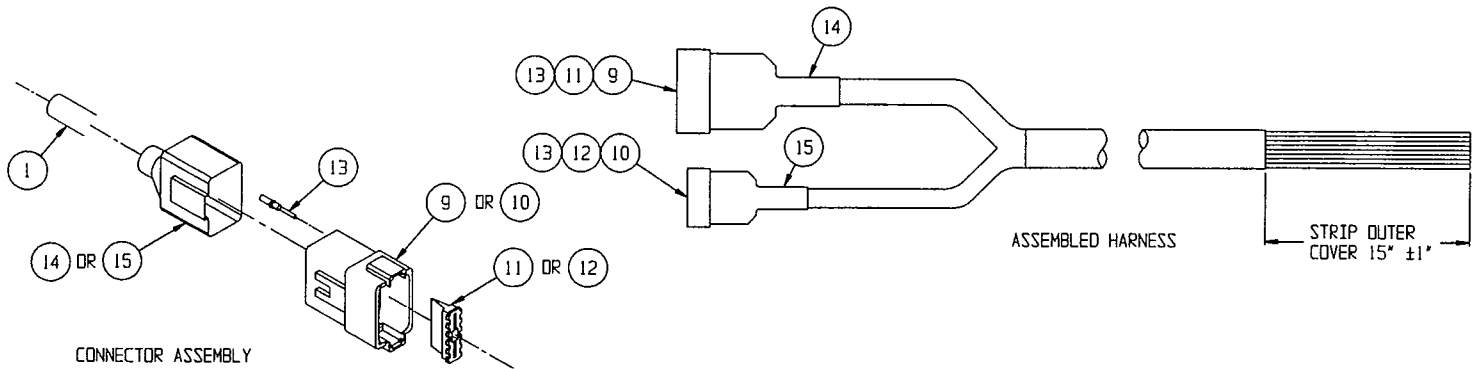

NOTES: UNLESS OTHERWISE SPECIFIED

1. CRIMP ON PINS AND CONNECTORS ARE INSTALLED (AFTER) CABLES ARE ROUTED THRU SCISSOR ARMS AND INTO CONTROL BOXES.

**Section
6.1**

ILLUSTRATED PARTS BREAKDOWN

**POWER MODULE, LX50
TWO-WHEEL DRIVE, DUAL FUEL
067522-010**

ITEM	PART NO.	DESCRIPTION	QTY.
1	067809-002	HINGE, 2 X 65	1
2	067811-002	POWER MODULE WELDMENT	1
3	067800-001	MODULE DOOR, R.H.	1
4	067801-001	MODULE DOOR, L.H.	1
5	067799-006	MODULE COVER	1
6	067808-000	HINGE, 2 X 22	2
7	026554-002	POP RIVET, 1/4 DIA. (.251 - .375 GRIP)	32
8	005299-000	LATCH, TOGGLE	2
9	067629-000	LATCH, FLUSH LIFT & TURN	2
10	067523-010	ENGINE ASSY, DUAL FUEL KUBOTA	1
11	011939-021	FITTING 12MP-12MJ	1
12	014220-009	FITTING 16MP-12FP	1
13	063935-001	SUCTION SCREEN	1
14	067841-000	TANK, HYDRAULIC	1
16	025427-002	HANDLE	1
17	026533-002	RIVET POP, 3/16D .126 -.250 GRIP	4
18	067856-000	STIFFENER BAR	1
19	011708-004	SCREW RD HD 8-32 X 1/2	4
20	011248-002	NUT HEX 8-32 ESNA	4
21	011254-006	SCREW HHC 3/8-16 X 3/4	2
22	064039-001	HYDRAULIC TANK MOUNTING TAB	1
23	067624-000	HYDRAULIC FILTER	1
*	067624-010	FILTER ELEMENT	1
24	011916-011	ELBOW 90° 20FP-20FP (1-1/4 NPT)	1
25	067854-000	ANGLE RES. MOUNT	1
26	011240-006	WASHER 3/8 FLAT STD	26
27	011254-008	SCREW HHC 3/8-16 X 1	12
28	011248-006	NUT HEX 3/8-16 ESNA	14
29	063650-012	SPRING, PRESSURIZED GAS	1
30	067648-008	END FITTING, GAS SPRING	REF
31	015936-004	SCREW SHOULDER 3/8Ø X 1/2	2
33	011939-030	FITTING 20MP-20MJ	1

ITEM	PART NO.	DESCRIPTION	QTY.
34	011923-008	FITTING 12MP-6FP	1
35	011940-008	FITTING 90° 6MP-4MJ	1
36	067898-000	RADIATOR COVER	1
37	063930-001	BREATHER/FILLER CAP	1
38	021305-007	PLUG, MAGNETIC	1
39	067696-000	EXHAUST TUBE, DUAL FUEL	1
40	067902-000	BRACKET, GAS SPRING	1
41	010070-099	SEAL STRIP GASKET	FT 2.54
42	067691-001	SNORKEL WELDMENT, DUAL FUEL	1
43	013259-007	MUFFLER CLAMP 1 3/4	1
44	067697-000	BREATHER SPACER (RADIATOR)	1
45	011252-008	SCREW HHC 1/4-20 X 1	10
46	011240-004	WASHER FLAT STD 1/4	10
47	064462-023	PLUG, 3/8 CAP	2
48	013259-006	CLAMP, MUFFLER 1-1/2"	2
49	063979-006	GAGE, LUBE SIGHT	1
50	011248-004	NUT HEX ESNA 1/4-20	6
51	066697-099	PIPE INSULATION 1-3/8Ø	1
52	011248-005	NUT HEX 5/16-18 ESNA	2
53	011253-007	SCREW HHC 5/16-18 X 7/8	4
54	011240-005	WASHER 5/16 FLAT STD	4
55	011238-005	WASHER LOCK 5/16	4
56	011250-005	NUT HEX 5/16-18	4
59	011939-013	FITTING 8MP-4MJ	1
60	011939-015	FITTING 8MP-8MJ	1
61	011939-014	FITTING 8MP-6MJ	1
62	063936-024	MUFFLER GASKET	1
63	067765-000	TUBE EXTENSION	1
64	011253-008	SCREW, HHC 5/16-18 X 1	2
65	011248-005	NUT, HEX 5/16-18 ESNA	2

*Not Shown

Local Distributor:

Lokaler Vertriebshändler:

Distributeur local:

El Distribuidor local:

Il Distributore locale:

USA

TEL: +1 (559) 443 6600
FAX: +1 (559) 268 2433

UpRight
POWERED ACCESS

www.upright.com

Europe

TEL: +44 (0) 845 1550 058
FAX: +44 (0) 195 2299 948

PN-