

UpRight

POWERED ACCESS



WARNING



The MX19 Machine has been re-assessed to ensure compliance to the Machinery Directive (2006/42/EC).

The Machine rating has been changed from:

Windspeed rating of 12.5 m/s (Beaufort 6)

To

Windspeed rating of 7 m/s (Beaufort 4)

Please attach to the front cover of
your MX19 manual

510328-000

MX19

WORK PLATFORM

SERVICE & PARTS MANUAL

MX19

Serial Numbers 50870 – 53195

ENGLISH

When contacting UpRight for service or parts information, be sure to include the MODEL and SERIAL NUMBERS from the equipment nameplate. Should the nameplate be missing, the SERIAL NUMBER is also stamped on top of the chassis above the front axle pivot.

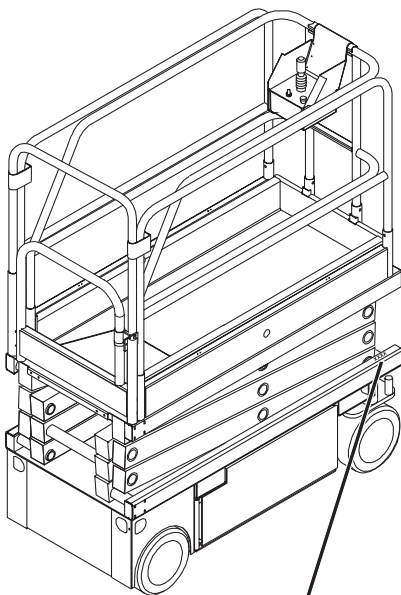

Stamped Serial Number

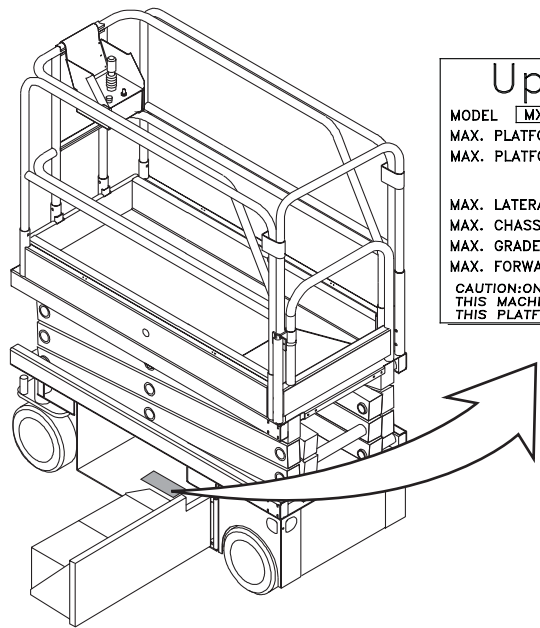

UpRight		VIGO CENTRE WASHINGTON TYNE & WEAR, UK		CE
MODEL	MX 19	SERIAL No.		
MAX. PLATFORM HEIGHT	5.8m	UNLADEN WEIGHT	1365 Kg	
MAX. PLATFORM LOAD	227 Kg = 2 Persons Indoor + Equipment 1 Persons Outdoor			
MAX. LATERAL FORCE	400N Indoor 200N Outside	MAX. WIND SPEED	12.5 m/s	
MAX. CHASSIS INCLINATION	2°	BATTERY VOLTAGE	24V	
MAX. GRADEABILITY	25%	CHARGER INPUT VOLTAGE	110/220V	
MAX. FORWARD SPEED	1.0 m/s	NOMINAL POWER	3kW	
CAUTION: ONLY TRAINED & AUTHORISED PERSONNEL MAY USE THIS MACHINE—CONSULT OPERATORS MANUAL BEFORE USE. THIS PLATFORM IS NOT ELECTRICALLY INSULATED 503725-000				



MX19 SERVICE AND PARTS MANUAL

PART NUMBER : 503727-002 (11-07)

SERIAL No. 50870

FOREWORD

HOW TO USE THIS MANUAL

This manual is divided into six sections.

SECTION 1 INTRODUCTION

General description and machine specifications.

SECTION 2 OPERATION AND SPECIFICATIONS

Information on how to operate the work platform and how to prepare it for operation.

SECTION 3 MAINTENANCE

Preventative maintenance and service information.

SECTION 4 TROUBLESHOOTING

Causes and solutions to typical problems.

SECTION 5 SCHEMATICS

Schematics and valve block diagram with description and location of components. Large schematic drawings may be located in the back of the manual.

SECTION 6 ILLUSTRATED PARTS BREAKDOWN

Complete parts lists with illustrations. Large parts drawings may be located in the back of the manual.

SPECIAL INFORMATION

DANGER

Indicates an imminently hazardous situation which, if not avoided, will result in severe injury or death.

WARNING

Indicates a potentially hazardous situation which, if not avoided, could result in severe injury or death.

CAUTION

Indicates a potentially hazardous situation which, if not avoided, may result in minor or moderate injury.

NOTE: Gives helpful information.

WORKSHOP PROCEDURES

All information contained in this manual is based on the latest product information available at the time of printing. We reserve the right to make changes at any time without notice. No part of this publication may be reproduced, stored in retrieval system, or transmitted, in any form by any means, electronic, mechanical, photocopying, recording, or otherwise, without the prior written permission of the publisher. This includes text, figures, and tables.

CAUTION

Detailed descriptions of standard workshop procedures, safety principles and service operations are not included. Note that this manual does contain warnings and cautions against some specific service methods that could cause personal injury, or could damage a machine or make it unsafe.

Please understand that these warnings cannot cover all conceivable ways in which service, whether or not recommended by UpRight, might be done, or of the possible hazardous consequences of each conceivable way, nor could UpRight investigate all such ways.

Anyone using service procedures or tools, whether or not recommended by UpRight must satisfy themselves thoroughly that neither personal safety nor machine safety will be jeopardized. When in doubt, contact your local distributor or UpRight.

INTRODUCTION

1.1 INTRODUCTION

PURPOSE

The purpose of this service and parts manual is to provide instructions and illustrations for the operation and maintenance of the MX19 manufactured by UpRight Powered Access.

SCOPE

The manual includes procedures for proper operation, maintenance, adjustment, and repair of the MX19 as well as recommended maintenance schedules and troubleshooting.

1.2 GENERAL DESCRIPTION

The MX19 consists of the platform, controller, elevating assembly, power module, control module, and chassis.

! WARNING !

DO NOT use the work platform without guardrails properly assembled and in place.

Figure 1-1: MX19 Work Platform

PLATFORM

The platform has a reinforced steel floor, 1.11 m (43.75 inch) high guardrails with midrail, 6 inch (152 mm) toeboards, and an entrance gate at the rear of the platform.

PLATFORM CONTROLLER

The platform controller contains the controls to operate the machine. It is located at the front of the platform. A complete explanation of control functions can be found in Section 2.

ELEVATING ASSEMBLY

The platform is raised and lowered by the elevating assembly. The hydraulic pump, driven by an electric motor, powers the cylinder. Solenoid operated valves control raising and lowering.

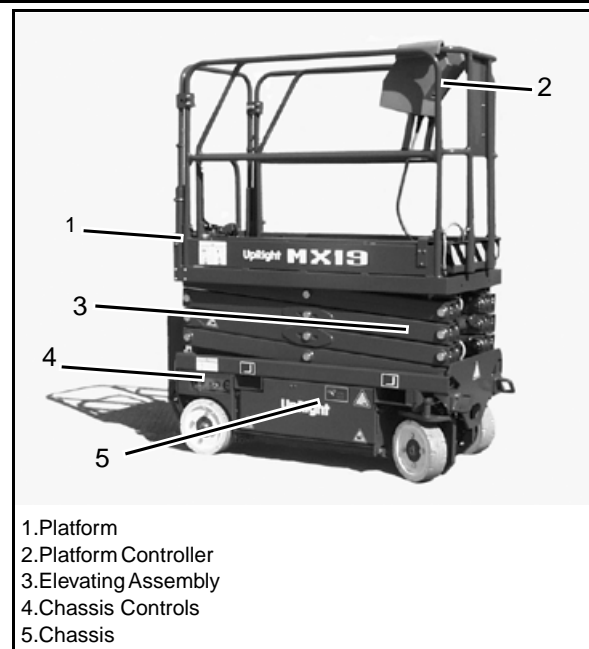

1. Platform
2. Platform Controller
3. Elevating Assembly
4. Chassis Controls
5. Chassis

CHASSIS

The chassis is a structural frame that supports all the components of the MX19 work platform. The platform is raised and lowered using a scissors mechanism. Lift is achieved using a single stage cylinder.

PURPOSE OF EQUIPMENT

The objective of the work platform is to provide a quickly deployable, self-propelled, variable height work platform to elevate personnel and materials to overhead work areas.

2. OPERATION MANUAL

WARNING

All personnel shall carefully read, understand and follow all safety rules and operating instructions before operating or performing maintenance on any UpRight aerial work platform.

Safety Rules

Electrocution Hazard

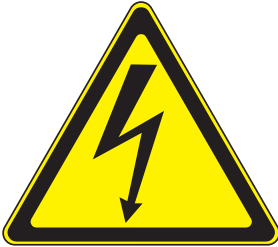

THIS MACHINE IS NOT INSULATED!

Tip Over Hazard

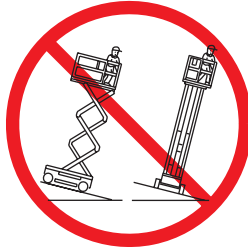

NEVER elevate the platform or drive the machine while elevated unless the machine is on a firm, level surface.

Collision Hazard



NEVER position the platform without first checking for overhead obstructions or other hazards.

Fall Hazard

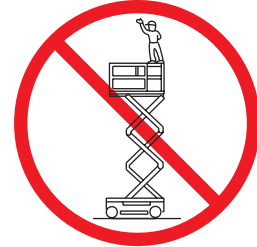

NEVER climb, stand, or sit on platform guardrails or midrail.

USE OF THE AERIAL WORK PLATFORM: This aerial work platform is intended to lift persons and his tools as well as the material used for the job. It is designed for repair and assembly jobs and assignments at overhead workplaces (ceilings, cranes, roof structures, buildings etc.). All other uses of the aerial work platform are prohibited!

THIS AERIAL WORK PLATFORM IS NOT INSULATED! For this reason it is imperative to keep a safe distance from live parts of electrical equipment!

Exceeding the specified permissible maximum load **is prohibited!** See “Special Limitations” on page 3 for details.

The use and operation of the aerial work platform as a lifting tool or a crane (lifting of loads from below upwards or from up high on down) **is prohibited!**

NEVER exceed the manual force allowed for this machine. See “Special Limitations” on page 3 for details.

DISTRIBUTE all platform loads evenly on the platform.

NEVER operate the machine without first surveying the work area for surface hazards such as holes, drop-offs, bumps, curbs, or debris; and avoiding them.

OPERATE machine only on surfaces capable of supporting wheel loads.

NEVER operate the machine when wind speeds exceed this machine’s wind rating. See “Beaufort Scale” on page 4 for details.

IN CASE OF EMERGENCY push EMERGENCY STOP switch to deactivate all powered functions.

IF ALARM SOUNDS while platform is elevated, STOP, carefully lower platform. Move machine to a firm, level surface.

Climbing up the railing of the platform, standing on or stepping from the platform onto buildings, steel or prefab concrete structures, etc., **is prohibited!**

Dismantling the swing gate or other railing components **is prohibited!** Always make certain that the swing gate is closed and securely locked!

It is prohibited to keep the swing gate in an open position (held open with tie-straps) when the platform is raised!

To extend the height or the range by placing of ladders, scaffolds or similar devices on the platform **is prohibited!**

NEVER perform service on machine while platform is elevated without blocking elevating assembly.

INSPECT the machine thoroughly for cracked welds, loose or missing hardware, hydraulic leaks, loose wire connections, and damaged cables or hoses before using.

VERIFY that all labels are in place and legible before using.

NEVER use a machine that is damaged, not functioning properly, or has damaged or missing labels.

To bypass any safety equipment **is prohibited** and presents a danger for the persons on the aerial work platform and in its working range.

NEVER charge batteries near sparks or open flame. Charging batteries emit explosive hydrogen gas.

Modifications to the aerial work platform **are prohibited** or permissible only at the approval by UpRight.

AFTER USE, secure the work platform from unauthorized use by turning both keyswitches off and removing key.

CONTENTS

Introduction	3
General Description	3
Special Limitations	3
Platform Capacity	4
Manual Force	4
Beaufort Scale	4
Lift Overload Alarm	4
Controls and Indicators	5
Pre-Operation Safety Inspection	6
System Function Inspection	7
Operation	8
Platform Extension	8
Travel With the Platform Lowered	8
Steering	8
Elevating the Platform	9
Travel With the Platform Elevated	9
Lowering the Platform	9
Emergency Lowering	9
After Use Each Day	10
Hour Meter	10
Transporting the Work Platform	11
By Crane	11
By Forklift	11
By Truck	11
Maintenance	12
Blocking The Elevating Assembly	12
Scissor Brace Installation	12
Scissor Brace Stowage	12
Battery Maintenance	13
Battery Charging	13
Inspection and Maintenance Schedule	14
Daily Preventative Maintenance Checklist	14
Specifications	15

INTRODUCTION

This manual covers the application of the MX19 Self-Propelled Work Platform.

This manual must be stored on the machine at all times.

GENERAL DESCRIPTION

! WARNING !

DO NOT use the maintenance platform without guardrails properly assembled and in place

1. Platform
2. Deck Extension
3. Platform Controls
4. Manual Case
5. Elevating Assembly
6. Chassis

Figure 1: MX Series

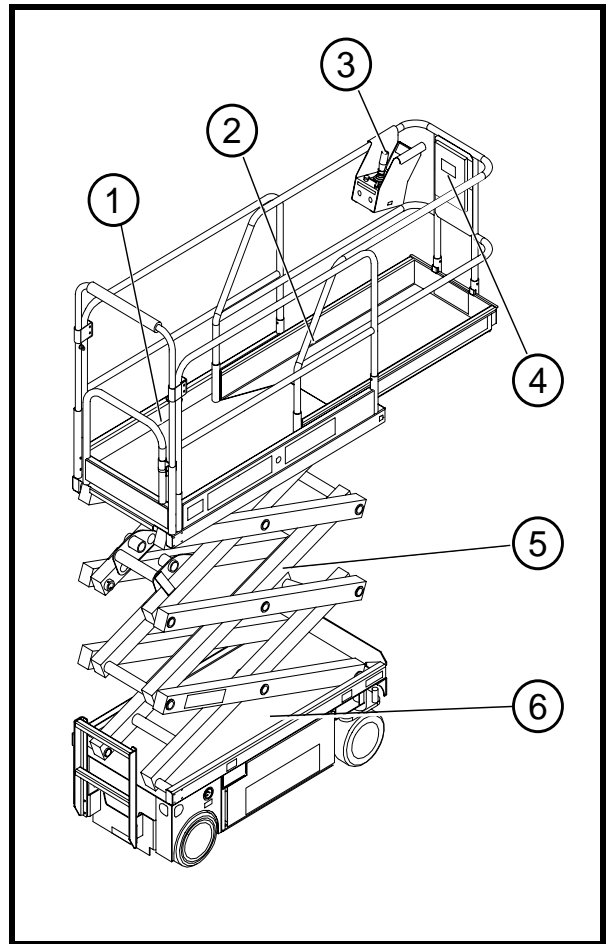

SPECIAL LIMITATIONS

Travel with the platform raised is limited to creep speed range.

Elevating the platform is limited to firm, level surfaces only.

! DANGER !

The elevating function shall **ONLY** be used when the work platform is level and on a firm surface.

The work platform is **NOT** intended to be driven over uneven, rough, or soft terrain.

PLATFORM CAPACITY

The maximum platform capacity for the MX 19 is 227 kg (500 lbs). Two people may occupy the platform indoors, while only one may occupy the platform outdoors.



DO NOT exceed the maximum platform capacity or the platform occupancy limits for this machine.

MANUAL FORCE

Manual force is the force applied by the occupants to objects such as walls or other structures outside the work platform.

The maximum allowable manual force is limited to 200 N (45 lbs.) of force per occupant, with a maximum of 400 N (90 lbs.) for two occupants.



DO NOT exceed the maximum amount of manual force for this machine.

BEAUFORT SCALE

Never operate the machine when wind speeds exceed 12.5 m/s (28mph) [Beaufort scale 6].

BEAUFORT RATING	WIND SPEED				GROUND CONDITIONS
	m/s	km/h	ft/s	mph	
3	3,4-5,4	12,25-19,4	11.5-17.75	7.5-12.0	Papers and thin branches move, flags wave.
4	5,4-8,0	19,4-28,8	17.75-26.25	12.0-18	Dust is raised, paper whirls up, and small branches sway.
5	8,0-10,8	28,8-38,9	26.25-35.5	18-24.25	Shrubs with leaves start swaying. Wave crests are apparent in ponds or swamps.
6	10,8-13,9	38,9-50,0	35.5-45.5	24.5-31	Tree branches move. Power lines whistle. It is difficult to open an umbrella.
7	13,9-17,2	50,0-61,9	45.5-56.5	31.-38.5	Whole trees sway. It is difficult to walk against the wind.

LIFT OVERLOAD ALARM

The MX19 is equipped with a load sensing system, it operates in the following way.

If a load equivalent to 90% of safe working load is in the basket the RED LED on the platform control box will flash slowly

If the load continues to rise the RED LED will flash progressively faster until 100% of safe working load is reached

If a load equivalent to 100% of safe working load is in the basket the RED LED will stay on and an alarm will sound

If a load greater than the safe working load is in the basket the RED LED will stay on, an alarm will sound and all machine functions will cease to operate.

In order to return to normal operation a load equal to or less than the safe working load must be present in the basket and the power must be re-cycled, power can be re-cycled by pushing the emergency stop button and releasing it again.



Never operate the machine with a platform load greater than the rated capacity.

CONTROLS AND INDICATORS

Figure 2: Controls and Indicators

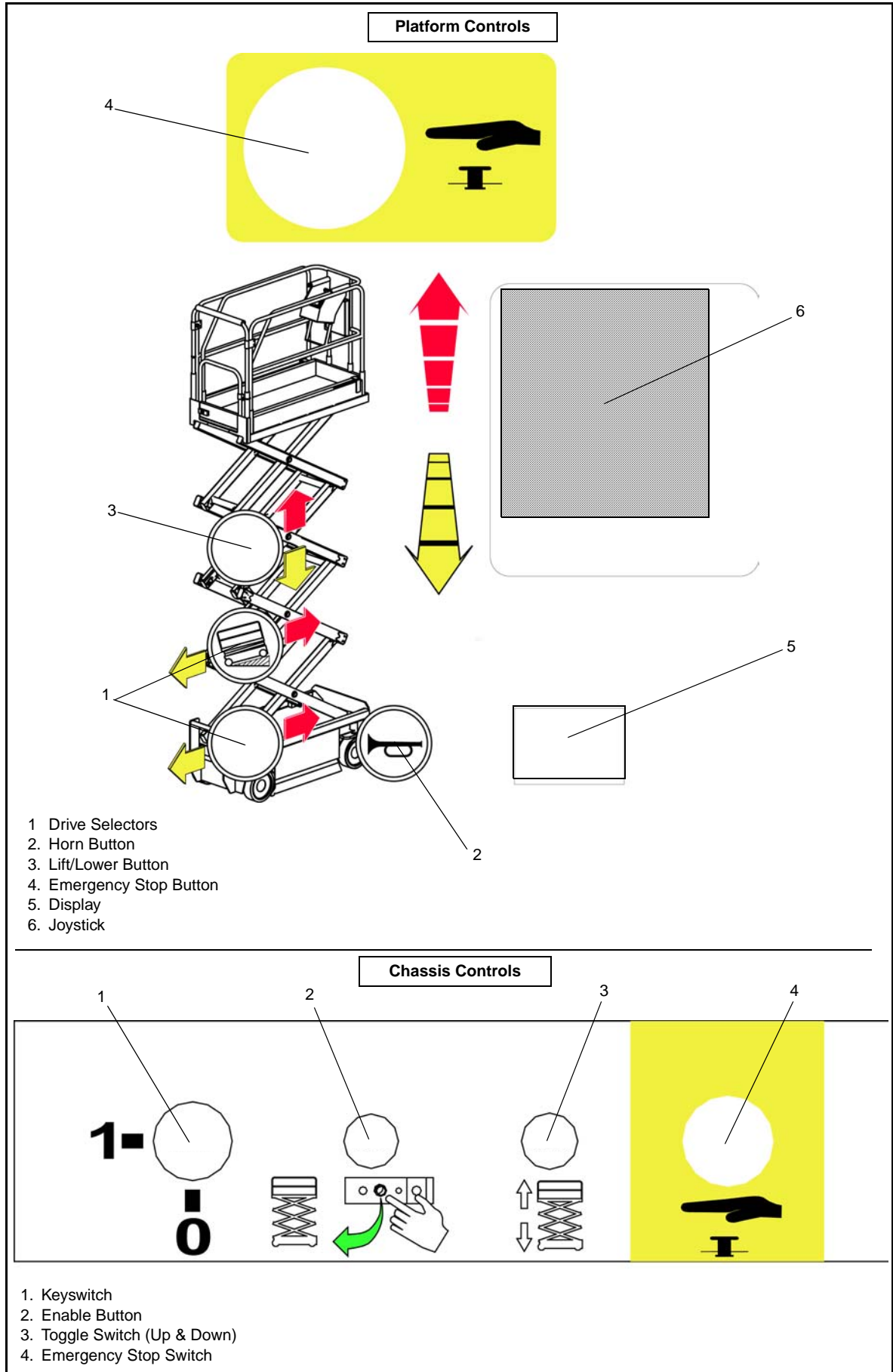

PRE-OPERATION SAFETY INSPECTION

NOTE: Carefully read, understand and follow all safety rules, operating instructions, labels and National Safety Instructions/Requirements. Perform the following steps each day before use.

1. Open modules and inspect for damage, fluid leaks or missing parts.

Figure 3: Hydraulic Tank

2. Check the level of the hydraulic fluid with the platform fully lowered. The hydraulic reservoir is located at the rear of the machine. The fluid level should be visible through the side of the tank, and must be between the MIN and MAX lines (see Figure 3). Add hydraulic fluid if necessary.

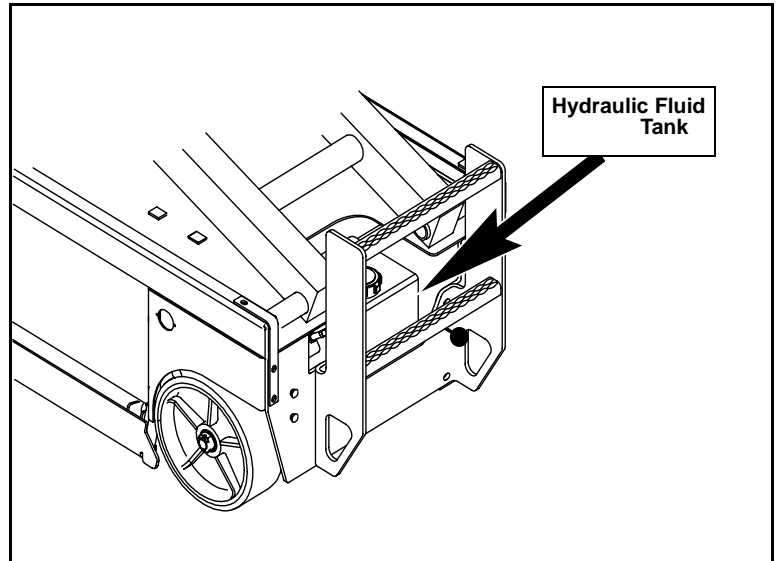

3. Check that fluid level in the batteries is correct (See Battery Maintenance, page 9).

4. Verify that batteries are charged.

5. Check that A.C. extension cord has been disconnected from the plug in the left Chassis Module, and that the module doors are closed and locked.

6. Check that all guardrails are in place and all fasteners are properly tightened.

7. Inspect the machine thoroughly for cracked welds and structural damage, loose or missing hardware, hydraulic leaks, damaged control cable, loose wire connections and wheel bolts.

SYSTEM FUNCTION INSPECTION

Refer to Figure 2 for the locations of various controls and indicators.

! WARNING !

STAND CLEAR of the work platform while performing the following checks.

Before operating the work platform, survey the work area for surface hazards such as holes, drop-offs, bumps and debris.

Check in **ALL** directions, including above the work platform, for obstructions and electrical conductors.

Protect the control console cable from possible damage while performing checks.

1. Move the machine, if necessary, to an unobstructed area to allow for full elevation.
2. Twist Chassis Emergency Stop Switch to the ON position.
3. Twist Platform Emergency Stop Switch to the ON position.
4. Turn the Chassis Key Switch to ON. Push the Chassis Lift/Lower Switch to the UP position and raise the platform approximately 2,1 m (7 feet). **BLOCK THE ELEVATING ASSEMBLY AS DESCRIBED ON page 12.**
5. Visually inspect the elevating assembly, lift cylinder, cables, and hoses for cracked welds and structural damage, loose hardware, hydraulic leaks, loose wire connections, and erratic operation. Check for missing or loose parts.
6. Verify that the Depression Mechanism Supports have rotated into position under the machine. **REMOVE THE SCISSOR BRACE AS DESCRIBED ON page 12.**
7. Push the Chassis Lift/Lower Switch to the UP position and fully elevate the platform. Partially lower the platform by pushing Chassis Lift/Lower Switch to LOWER, and check for proper operation of the audible lowering alarm.
8. Open the Emergency Lowering Valve (see Figure 3) by pulling the knob out to check for proper operation. When the platform is lowered, release the knob.
9. Push the Chassis Emergency Stop Switch to check for proper operation. All machine functions should be disabled. Twist the Chassis Emergency Stop Switch to resume.
10. Mount the platform.
11. Check that route is clear of obstacles (persons, obstructions, holes, and drop-offs, bumps and debris), is level, and is capable of supporting the wheel loads.
12. Mount the platform and properly close the entrance.
13. Select DRIVE mode. While engaging the Interlock Switch, move the Control Handle to FORWARD, then REVERSE, to check for speed control.
14. Push the Steering Switch RIGHT, then LEFT, to check for steering control.
15. Select LIFT mode. Grasp the Control Handle, engaging the Interlock Switch, and push it forward to check platform lift controls. Raise the platform to full elevation.
16. Pull back on the Control Handle. The platform should descend and the audible lowering alarm should sound.
17. Push the Platform Emergency Stop Switch to check for proper operation. All machine functions should be disabled. Pull out the Platform Emergency Stop Switch to resume.

OPERATION

Before operating the work platform, ensure that the Pre-Operation Safety Inspection has been completed and that any deficiencies have been corrected. **Never operate a damaged or malfunctioning machine.** The operator must be thoroughly trained on this machine.

PLATFORM EXTENSION

1. Mount the platform and properly close the entrance.
2. Depress the foot lever located at the rear of the platform extension. Push the platform extension forward until the pin engages the front stop.
3. To retract the platform extension, depress the foot lever and pull the platform extension toward the rear of the machine until the pin engages the rear stop.

Figure 4: Platform Extension

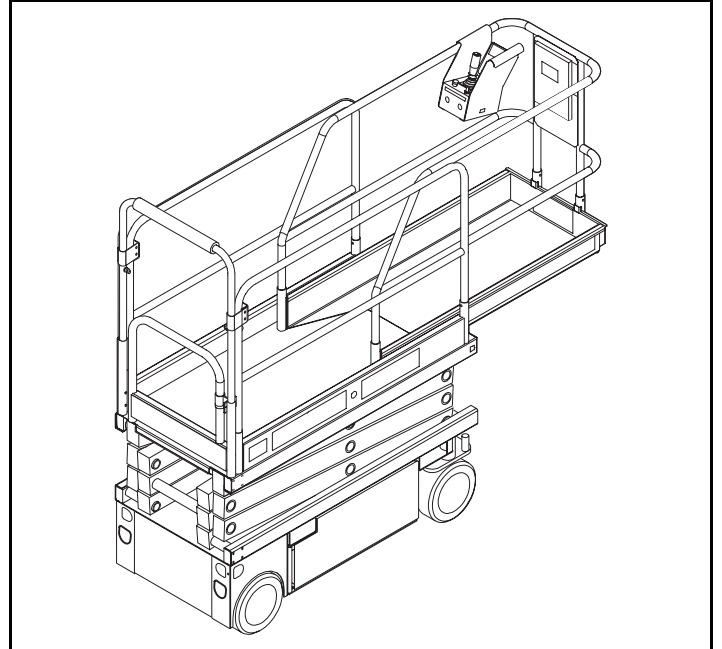

TRAVEL WITH THE PLATFORM LOWERED

1. Check that the route is clear of obstacles (persons, obstructions, holes, drop-offs, bumps, and debris), is level, and is capable of supporting the wheel loads.
2. Verify that the Chassis Key Switch is turned to DECK and Chassis Emergency Stop Switch is ON (pulled out).
3. Mount the platform and properly close the entrance.
4. Check clearances above, below, and to the sides of platform.
5. Pull the Platform Emergency Stop Switch out to the ON position.
6. Turn the Drive/Lift Switch to DRIVE.
7. Engage the Interlock Switch and move the Control Handle to FORWARD or REVERSE to travel in the desired direction. The speed of the machine will vary depending on how far from center the Control Handle is moved.

STEERING

1. Turn the Drive/Lift Switch to DRIVE.
2. While engaging the Interlock Switch, push the Steering Switch to RIGHT or LEFT to turn the wheels in the desired direction. Observe the tires while maneuvering the work platform to ensure proper direction.

NOTE: Steering is not self-centering. Wheels must be returned to the straight ahead position by operating the Steering Switch.

ELEVATING THE PLATFORM

1. Select a firm, level surface.
2. Select LIFt mode.
3. While engaging the Interlock Switch, push the Control Handle forward.
4. If the machine is not level the tilt alarm will sound and the machine will not lift or drive. **If the tilt alarm sounds the platform must be lowered and the machine moved to a firm level surface before attempting to re-elevate the platform.**

NOTE: Depression Mechanism supports will deploy automatically as the platform elevates and will retract after the platform has been lowered completely and has been driven.

TRAVEL WITH THE PLATFORM ELEVATED

NOTE: The machine will travel at reduced speed when the platform is elevated.

1. Check that the route is clear of obstacles (persons, obstructions, holes, drop-offs, bumps, and debris), is level, and is capable of supporting the wheel loads.
2. Check clearances above, below, and to the sides of platform.
3. Select DRIVE mode.
4. Engage the Interlock Switch and move the Control Handle to FORWARD or REVERSE to travel in the desired direction. The speed of the machine will vary depending on how far from center the Control Handle is moved.
5. If the machine is not level the tilt alarm will sound and the machine will not lift or drive. **If the tilt alarm sounds the platform must be lowered and the machine moved to a firm, level surface before attempting to re-elevate the platform.**

LOWERING THE PLATFORM

1. Select LIFT mode.
2. Check around the base of the platform to ensure that no one is in contact with the machine. Engage the Interlock Switch and pull back on the Control Handle to lower the platform.
3. The platform will stop when it reaches the PPE cutout height. Inspect around the machine to ensure no one is in contact with the machine. After a four-second time delay, lower the platform as in step 2.

EMERGENCY LOWERING

⚠ WARNING ⚠

*If the platform should fail to lower, NEVER climb down the elevating assembly.
Stand clear of the elevating assembly while operating the Emergency Lowering Valve Knob.*

The Emergency Lowering Valve Knob is located beside the ladder at the rear of the machine.

1. Open the Emergency Lowering Valve by pulling and holding the knob.
2. To close, release the knob. The platform will not elevate if the Emergency Lowering Valve is open.

Figure 5: Emergency Lowering

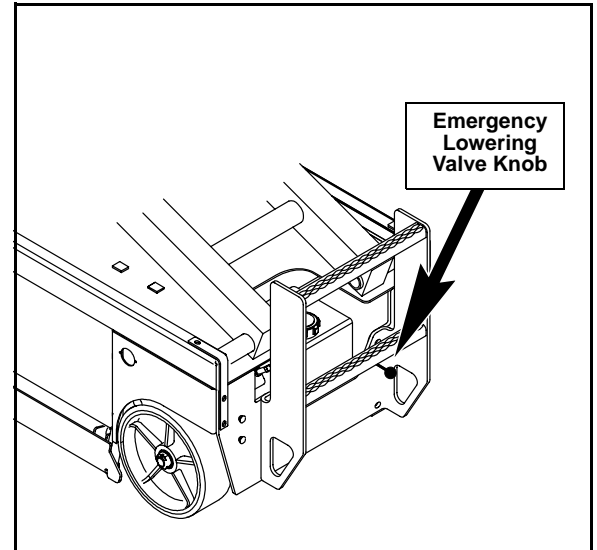

⚠ WARNING ⚠

Never tow faster than 0,3 m/sec. (1 ft./sec.).

AFTER USE EACH DAY

1. Ensure that the platform is fully lowered.
2. Park the machine on a firm level surface, preferably under cover, secure against vandals, children and unauthorized operation.
3. Turn the Chassis Key Switch to OFF and remove the key to prevent unauthorized operation.

HOUR METER

To access the hour meter function perform the following steps.

1. Climb into the basket (with the machine powered up)
2. Push the platform emergency stop button.
3. Hold down the following buttons, Horn and Lift.
4. While holding the buttons twist the emergency stop button to return power to the machine.
5. "hr" will now be displayed on the read-out, Pressing the right turn button will scroll through the accumulated hours two digits at a time. For example, if pressing the right turn button once displays "20", pressing it a 2nd time displays "58", and pressing it a 3rd time displays "hr", the elapsed time of operation is 2058 hours.

TRANSPORTING THE WORK PLATFORM

BY CRANE

Secure the straps to Tie Down/Lifting D-Rings only.

BY FORKLIFT

⚠ DANGER ⚠

Forklifting is for transport only.

See specifications for weight of work platform and be certain that forklift is of adequate capacity to lift the work platform.

The MX19 may be forklifted from the rear end of the machine between the wheels. It may also be forklifted from the side using the forklift pockets shown in the diagram.

Figure 6: Transporting the Work Platform

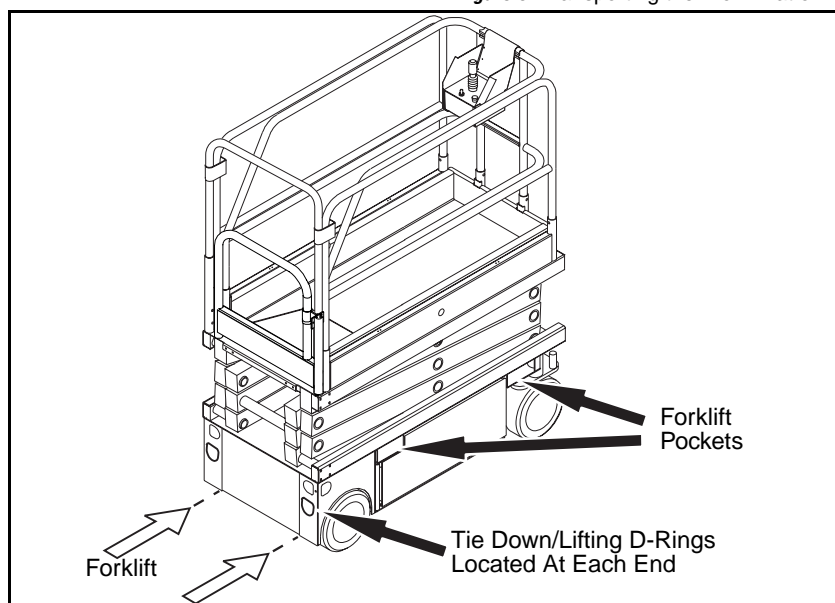

BY TRUCK

Manoeuvre the work platform into transport position and chock the wheels. Secure the work platform to the transport vehicle by attaching chains or straps of adequate load capacity to the Tie Down/Lifting D-Rings.

CAUTION

Over tightening of the chains or straps attached to the Tie Down/Lifting D-Rings may result in damage to work platform.

MAINTENANCE

⚠ WARNING ⚠

Never perform service while the platform is elevated without first blocking the elevating assembly.
DO NOT stand in the elevating assembly area while deploying or storing the brace.

BLOCKING THE ELEVATING ASSEMBLY

SCISSOR BRACE INSTALLATION

1. Park the work platform on a firm, level surface. Completely unload the platform before installing the Scissor Brace.
2. Verify that the Chassis and Platform Emergency Stop Switches are ON by twisting each button.
3. Turn and hold the Chassis Key Switch to CHASSIS. Push the Chassis Lift/Lower Switch to UP and elevate the platform approximately 2,1 m (7 ft.).
4. Rotate the Scissor Brace to a vertical position.
5. Carefully lower the platform until the end of the Scissor Arm Weldment rests on the Brace.

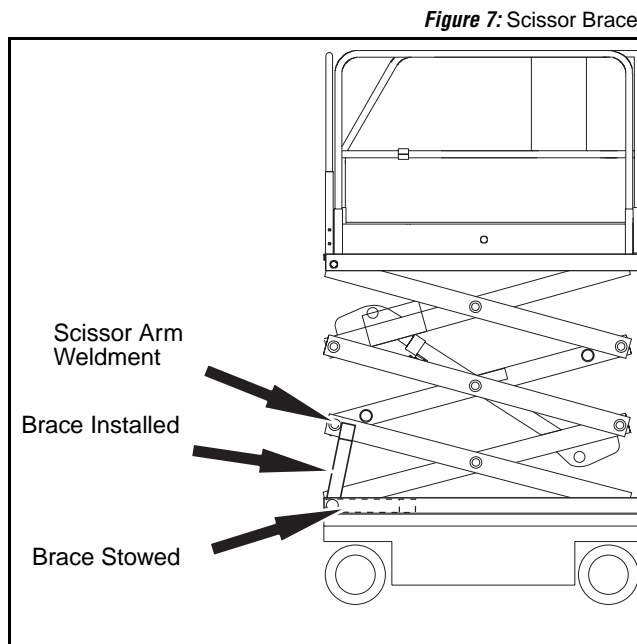

SCISSOR BRACE STOWAGE

1. While holding the Brace, slowly raise the platform using the Chassis Controls until the end of the Scissor Arm Weldment clears the Scissor Brace.
2. Rotate the Scissor Brace forward to rest on the Chassis.
3. Push the Chassis Lift/Lower Switch to LOWER and completely lower the platform.

BATTERY MAINTENANCE

Figure 8: Access to Batteries

WARNING

Hazard of explosive gas mixture. Keep sparks, flame, and smoking material away from batteries.

Always wear safety glasses when working near batteries.

Battery fluid is highly corrosive. Thoroughly rinse away any spilled fluid with clean water.

Always replace batteries with UpRight batteries or manufacturer approved replacements weighing 26,3 kg (58 lbs.) each.



- Check the battery fluid level daily, especially if the machine is being used in a warm, dry climate.
- Keep the terminals and tops of the batteries clean.
- Refer to the Service Manual to extend battery life and for complete service instructions.

BATTERY CHARGING

Figure 9: Battery Charge Indicator

WARNING

Charge the batteries in a well ventilated area.

Do not charge the batteries when the machine is near a source of sparks or flames.

Permanent damage to the batteries will result if the batteries are not immediately recharged after discharging.

Never leave the battery charger operating for more than two days.

Never disconnect the cables from the batteries when the charger is operating.

Keep the charger dry.

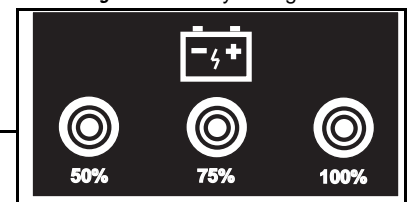

1. Check the battery fluid level. If the battery fluid level is lower than 10 mm ($\frac{3}{8}$ in.) above the plates add distilled water only.
2. Connect an extension cord (1,5 mm² [12 gauge] minimum conductor diameter; 15 m (50 ft.) maximum length) to the charger plug located at the left side of the chassis.
3. The charger turns on automatically after a short delay. Look through the charge indicator cutout to check the state of charge.
 - 0 - 50% charge:
 - First Light -BLINKING-
 - Second and Third Light -OFF-
 - 50% - 75% Charge:
 - First Light -ON-
 - Second Light -BLINKING-
 - Third Light -OFF-
 - 75% - 100% Charge:
 - First and Second Light -ON-
 - Third Light - BLINKING-
 - Charge Complete
 - All Lights -ON-
 - The charger automatically shuts down to low current after charging is complete and all lights turn ON.
 - The charger continues at low current (equalizing charge) for 3-4 hours, then charging current shuts off completely.
4. Lights remain ON until the AC power supply is disconnected.

NOTE: The battery charger circuit must be used with a GFI (Ground Fault Interrupt) outlet.

NOTE: DO NOT operate the machine while the charger is plugged in.

INSPECTION AND MAINTENANCE SCHEDULE

The Complete Inspection consists of periodic visual and operational checks, along with periodic minor adjustments that assure proper performance. Daily inspection will prevent abnormal wear and prolong the life of all systems. The inspection and maintenance schedule should be performed at the specified intervals. Inspection and maintenance shall be performed by personnel who are trained and familiar with mechanical and electrical procedures.

⚠ WARNING ⚠

*Before performing preventative maintenance, familiarize yourself with the operation of the machine.
Always block the elevating assembly whenever it is necessary to perform maintenance while the platform is elevated.*

The daily preventative maintenance checklist has been designed for machine service and maintenance. Please photocopy the Daily Preventative Maintenance Checklist and use the checklist when inspecting the machine.

DAILY PREVENTATIVE MAINTENANCE CHECKLIST

MAINTENANCE TABLE KEY

INTERVAL

Y = Yes/Acceptable

N = No/Not Acceptable

R = Repaired/Acceptable

PREVENTATIVE MAINTENANCE REPORT

Date: _____

Owner: _____

Model No: _____

Serial No: _____

Serviced By: _____

COMPONENT	INSPECTION OR SERVICES	Y	N	R
Battery	Check electrolyte level.			
	Check battery cable condition.			
Chassis	Check hoses for pinch or rubbing points.			
	Check welds for cracks.			
Control Cable	Check the exterior of the cable for pinching, binding or wear.			
Controller	Check switch operation.			
Drive Motors	Check for operation and leaks.			
Elevating Assembly	Inspect for structural cracks.			
Emergency Lowering System	Operate the emergency lowering valve and check for serviceability.			
Entire Unit	Check for and repair collision damage.			
Hydraulic Fluid	Check fluid level.			
Hydraulic Pump	Check for hose fitting leaks.			
Hydraulic System	Check for leaks.			
Labels	Check for peeling, missing, or unreadable labels & replace.			
Platform Deck and Rails	Check welds for cracks.			
	Check condition of deck.			
Tyres	Check for damage.			

SPECIFICATIONS

ITEM	MX19
Platform Size (Inside minimum) Standard w/Deck	0,57 m x 2,5 m (22.5 in. x 98.5 in.)
Maximum Platform Capacity Standard w/Deck Extension	227 kg (500 lbs.)
Maximum Number of Occupants Standard w/Deck Extension on Extension	2 People indoors/1 person outdoors 1 Person
Height Working Height Maximum Platform Height Maximum Drivable Height	7,8 m (25 ft. 6 in.) 5,8 m (19 ft.) 5,8 m (19 ft.)
Dimensions Weight Overall Width Overall Height (Lowered) Overall Length (Deck in)	1406 kg (3100 lbs.) 760 mm (30 in.) 2,02 m (79.5 in.) 1,60 m (63 in.)
Drive Speed Platform Lowered Platform Raised	3,7 km/h (2.3 mph) 1,0 km/h (0.62 mph)
Energy Source	24 V battery pack (4-220 A hour, 6 V batteries, min. wt. 26,3 kg [58 lbs.] each), 4 HP DC electric motor
System Voltage	24 V DC
Battery Charger	20 A, 240 V AC 50 Hz, Automatic
Hydraulic Tank Capacity	12,9 L (3.4 US gal.)
Maximum Hydraulic System Pressure	234 bar (3400 psi)
Hydraulic Fluid	
Normal above 32° F [0° C]	ISO #46
Low Temp. below 32° F [0° C]	ISO #32
below 0° F [-17° C]	ISO #15
Lift System	One Single Stage Lift Cylinder
Drive Control	Motor Control
Control System	Control Handle with Interlock Switch, Rotary Drive/Lift Switch, and Red Mushroom Emergency Stop Switch
Drive System	Dual Front Wheel Hydraulic Motors
Tyres	30,5 cm (12 in.) diameter solid rubber, Non-marking
Turning Radius (inside)	150 mm (6 in.) Inside
Maximum Gradeability	25% (14°)
Wheel Base	1,23 m (48.5 in.)
Guardrails	1,10 m (43 in.)
Toeboard	150 mm (6 in.)
Noise Level	

*Specifications are subject to change without notice. Hot weather or heavy use may affect performance.

Refer to the Service Manual for complete parts and service information.

The MX19 meets or exceeds all applicable CE and GS machinery directive requirements.

SERVICE AND REPAIR

This section contains instructions for the maintenance of the Work Platform. Refer to the General Information section for information relevant to all UpRight work platforms. Referring to the Operator Manual will aid in understanding the operation and function of the various components and systems of the work platform, and help in diagnosing and repair of the machine.

⚠ WARNING ⚠

Be sure to read, understand and follow all information in the Operation Section of this manual before attempting to operate or perform service on any Work Platform.

⚠ DANGER ⚠

*Never perform service on the work platform in the elevating assembly area while platform is elevated without first blocking the elevating assembly.
DO NOT stand in elevating assembly area while deploying or storing brace.*

TABLE OF CONTENTS

- 3-1 Supporting Elevating Assembly 3-3**
 - Installation 3-3
 - Removal. 3-3
- 3-2 Preventative Maintenance 3-4**
- 3-3 Preventative Maintenance Check List 3-5**
- 3-4 Parts Location 3-6**
- 3-5 General Lubrication 3-7**
- 3-6 Batteries 3-8**
 - Battery Replacement 3-8
 - Battery Maintenance 3-8
- 3-7 Hydraulics 3-9**
 - Hydraulic Oil Tank And Filter 3-9
 - Hydraulic Pump 3-10
 - Cylinder valve Assembly 3-11
 - Main Hydraulic Manifold 3-12
 - Setting Hydraulic Manifold Pressures 3-13
- 3-8 Cylinders 3-15**
 - Depression Cylinder 3-15
 - Steering Cylinder 3-16
 - Lift Cylinder 3-17
- 3-9 Drive Motors 3-18**
 - Removal. 3-18
 - Installation 3-18
- 3-12 Controls 3-19**
 - Platform Controls 3-19
 - Chassis Controls 3-20

LIST OF FIGURES

Figure 3-1: Supporting Elevating Assembly	3-3
Figure 3-2: Lubrication Points	3-7
Figure 3-3: Battery Cables	3-8
Figure 3-4: Hydraulic Oil Tank and Filter	3-9
Figure 3-5: Hydraulic Pump	3-10
Figure 3-6: Emergency Down	3-11
Figure 3-7: Hydraulic Manifold	3-12
Figure 3-8: Hydraulic Manifold	3-13
Figure 3-9: Depression Cylinder Remove & Replace	3-15
Figure 3-10: Steering Cylinder Remove & Replace	3-16
Figure 3-12: Drive Motor Assembly	3-17
Figure 3-13: Tilt Sensor	3-19
Figure 3-14: Upper Controls	3-20
Figure 3-15: Chassis Controls	3-21

3-1 SUPPORTING ELEVATING ASSEMBLY

⚠ WARNING ⚠

Never perform service on the work platform in the elevating assembly area while platform is elevated without first blocking the elevating assembly.

DO NOT stand in elevating assembly area while deploying or storing brace.

INSTALLATION

1. Park the Work Platform on firm level ground.
2. Verify Platform Emergency Stop Switch is **ON**.
3. Verify Platform Key Switch is **ON**.
4. Press the Enable button and push Chassis Lift/Lower toggle Switch to **UP** to elevate Platform approximately 1.2m (4 feet).
5. Lift the Scissor Brace into position, hold it perpendicular to the scissor member..
6. Press the Enable button and push Chassis Lift/Lower toggle Switch to **DOWN** position and gradually lower Platform until the Scissor Assembly is supported by the brace.

REMOVAL

1. Press the Enable button and push Chassis Lift/Lower toggle Switch to **UP** to gradually raise Platform until the brace can be removed.
2. Rotate the brace to the stowed position.
3. Press the Enable button and push Chassis Lift/Lower toggle Switch to **DOWN** position and completely lower Platform

Figure 3-1: Supporting Elevating Assembly

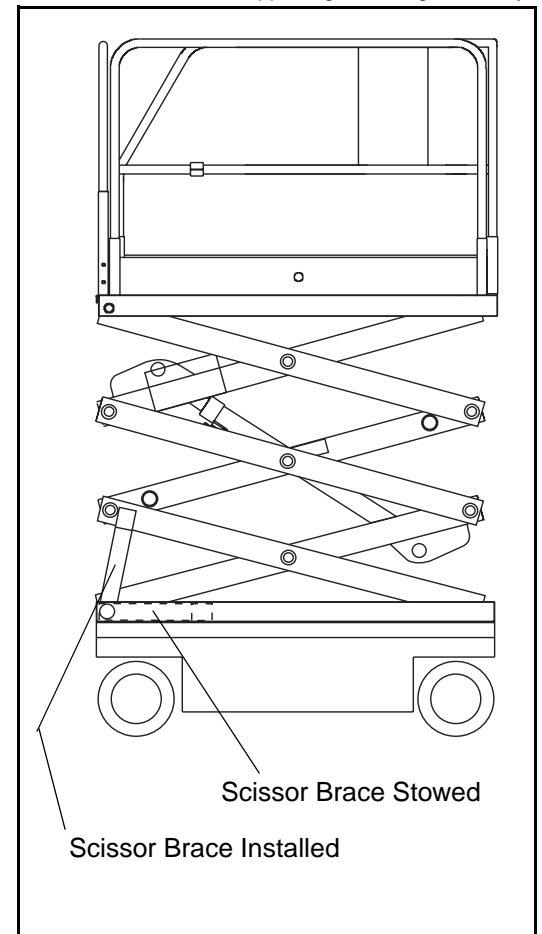

3-2 PREVENTATIVE MAINTENANCE

The complete inspection consists of periodic visual and operational checks, along with periodic minor adjustments to assure proper performance.

Daily inspection will prevent abnormal wear and prolong the life of all systems. The inspection and maintenance schedule is to be performed at regular intervals.

Inspection and maintenance shall be performed by personnel who are trained and familiar with mechanical and electrical procedures.

! WARNING !

Before performing preventative maintenance, familiarize yourself with the operation of the machine.

Always block the elevating assembly whenever it is necessary to enter the scissor assembly to perform maintenance while the platform is elevated.

The preventative maintenance table has been designed for machine service and maintenance repair. Please photocopy the following page and use the table as a checklist when inspecting the machine for service.

3-3 PREVENTATIVE MAINTENANCE CHECK LIST

PREVENTATIVE MAINTENANCE KEY

Interval

- Daily=each shift or every day
- 50h/30d=every 50 hours or 30 days
- 250h/6m=every 250 hours or 6 months
- 1000h/2y=every 1000 hours or 2 years
- Y=Yes/Acceptable
- N=No/Not Acceptable
- R=Repaired/Acceptable

PREVENTATIVE MAINTENANCE REPORT

Date: _____

Owner: _____

Model No: _____

Serial No: _____

Serviced By: _____

Service Interval: _____

COMPONENT	INSPECTION OR SERVICES	INTERVAL	Y	N	R
Battery System	Check electrolyte level	Daily			
	Check battery cable condition	Daily			
	Charge batteries	Daily			
	Check charger condition & operation	Daily			
	Check specific gravity	6m			
	Clean exterior	6m			
	Clean terminals	6m			
Hydraulic Oil*	Check oil level	Daily			
	Change Filter	6m			
	Drain and replace oil	2y			
Hydraulic System	Check for leaks	Daily			
	Check hose connections	30d			
	Check hoses for exterior wear	30d			
Drive Motors	Check for operation and leaks	Daily			
Emergency Down	Check procedure for Emergency Down	Daily			
Hydraulic Pump	Check for fitting leaks	Daily			
	Wipe clean	30d			
	Check for leaks at mating surfaces	30d			
	Check mounting bolts for proper torque	6m			
Controller	Check condition & operation	Daily			
Platform Deck & Rails	Check fasteners for proper torque	Daily			
	Check welds for cracks	Daily			
	Check condition of deck	Daily			
	Check entry way closure	Daily			

COMPONENT	INSPECTION OR SERVICES	INTERVAL	Y	N	R
Elevating Assembly	Inspect for external damage, dents, loose rivets or cracks	Daily			
Chassis	Check cables for pinch or rubbing points	Daily			
	Check welds for cracks	Daily			
	Check component mounting for proper torque	6m			
Lift Cylinder	Check for leaks	Daily			
	Check for proper torque	6m			
Entire Unit	Perform pre-operation inspection	Daily			
	Check for and repair collision damage	Daily			
	Lubricate	30d			
	Check fasteners for proper torque	6m			
Labels	Check for corrosion; remove and repaint	6m			
	Check for peeling, missing, or unreadable labels & replace	Daily			
Wheels	Check for loose components	Daily			
Steering System	Oil pivot pins	30d			
	Oil king pins	30d			
	Check steering cylinder for leaks	30d			
	Check hardware & fittings for proper torque	6m			

* NOTE: Use ISO #46 during summer and ISO #32 during winter.

3-4 PARTS LOCATION

Figure 3-2: Parts Location

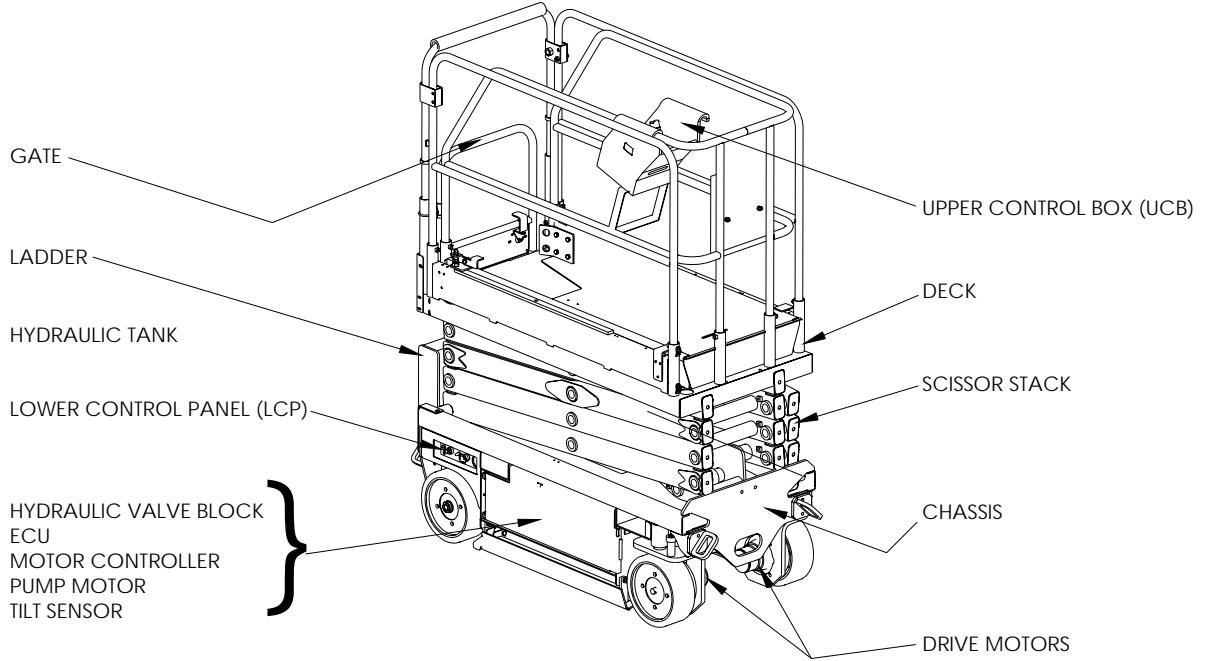

3-5 GENERAL LUBRICATION

Figure 3-3: Lubrication Points

- Apply grease to each grease fitting.

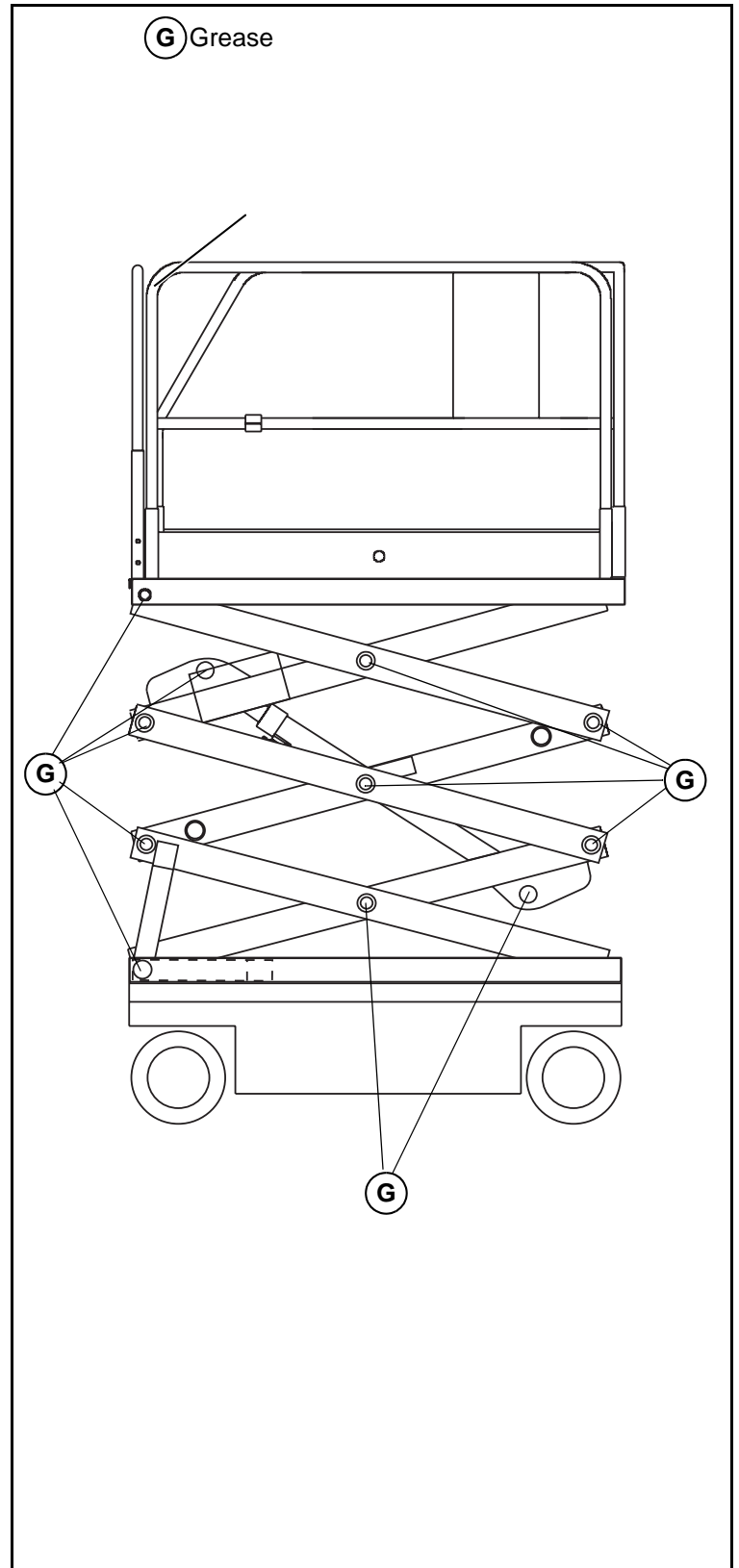

3-6 BATTERIES

Electrical Energy for the motor is supplied by four 6 volt batteries wired in series for 24 volts DC. Proper care and maintenance of the batteries and motor will ensure maximum performance from the work platform.

CAUTION

If battery water level is not maintained, batteries will not fully charge, creating a low discharge rate.

WARNING

Hazard of explosive gas mixture. Keep sparks, flame and smoking materials away from batteries.

Always wear safety glasses when working with batteries.

Battery fluid is highly corrosive. Thoroughly rinse away any spilled fluid with clean water.

Always replace batteries with UpRight batteries or manufacturer approved replacements.

Before disconnecting the battery negative (-) lead, make sure all switches are OFF. If ON, a spark will occur at the ground terminal which could cause an explosion if hydrogen gas or fuel vapors are present.

BATTERY REPLACEMENT

The batteries are located in a slide-out tray in the rear of the machine. There are four 6 volt batteries wired in series for 24 volts DC. Battery cables must be installed as shown in the Battery Cable Installation Diagram.

BATTERY MAINTENANCE

Refer to *Section 1: General Information* for complete battery maintenance instructions.

Refer to the *Operation Manual* included in this Service Manual for specific maintenance and charging instructions.

Figure 3-4: Battery Cables

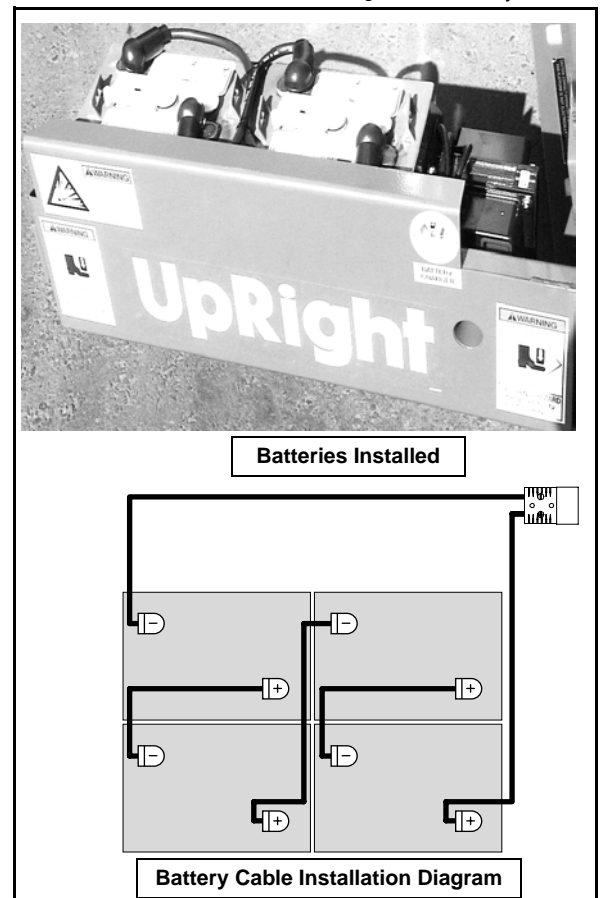

3-7 HYDRAULICS

HYDRAULIC OIL TANK AND FILTER

FLUID LEVEL

With the platform **fully lowered**, check the oil level through the side of the tank. The level should be between the “max” and “min” lines..

DO NOT fill above the MAX line on the tank.

DO NOT fill when the Platform is elevated.

OIL AND FILTER REPLACEMENT

1. Operate the work platform for 10-15 minutes to bring the hydraulic oil up to normal operating temperature.
2. Provide a suitable container to catch the drained oil. Hydraulic tank has a 12.9 liter (3.4 gal) capacity.
3. Remove the drain plug and allow all oil to drain. Dispose of hydraulic fluid properly--contact your local oil recycler.
4. Clean magnet on drain plug and reinstall.
5. Unscrew the filter (located beside valve block, easily accessed through the left module) from the filter assembly.
6. Apply a thin film of clean hydraulic oil to the gasket of the replacement filter.
7. Screw the replacement filter onto the filter head until the gasket makes contact, then rotate the filter 3/4 of a turn further.
8. Fill the hydraulic reservoir with hydraulic oil until the oil level is between the minimum and maximum lines on the tank. Do not fill above the maximum line on the tank. Hydraulic tank has a 12.9 liter (3.4 gal) capacity.
9. Operate all machine functions and recheck the fluid level. Add fluid if necessary.

Figure 3-5: Hydraulic Oil Tank and Filter

1. Filler Cap
2. Drain Line Fitting
3. Return Line Fitting
4. Suction Line Fitting
5. Suction Filter

NOTE : Drain plug underneath tank

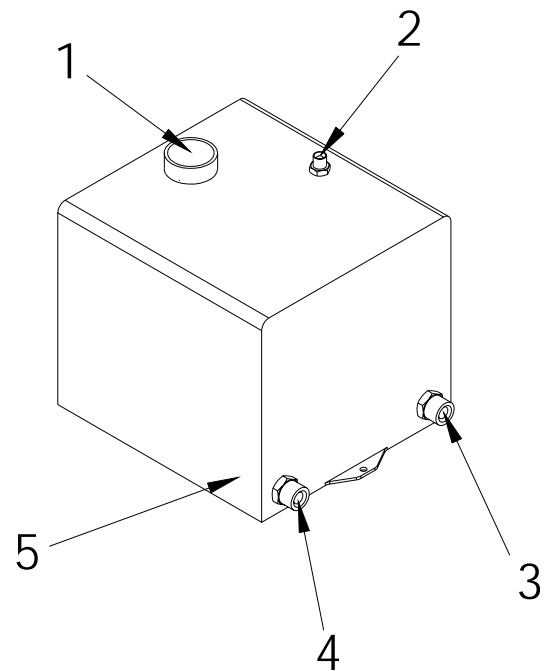

CAUTION

The hydraulic oil may be of sufficient temperature to cause burns. Wear safety gloves and safety glasses when handling hot oil.

HYDRAULIC PUMP

The Hydraulic Pump is located in the Power Module, and is mounted on the rear of the motor.

REMOVAL

NOTE: If the hydraulic tank has not been drained, suitable means for plugging the hoses should be provided to prevent excessive fluid loss.

1. Mark, disconnect and plug the hose assemblies.
2. Loosen the capscrews and remove the pump assembly from the motor.

INSTALLATION

1. Lubricate the pump shaft with general purpose grease and attach the pump to the motor with the capscrews.
2. Using a crisscross pattern, torque each cap-screw a little at a time until all capscrews are torqued to 27N-m (**20 ft-lbs**).
3. Unplug and reconnect the hydraulic hoses.
4. Check the oil level in the hydraulic tank before operating the work platform.

Figure 3-6: Hydraulic Pump

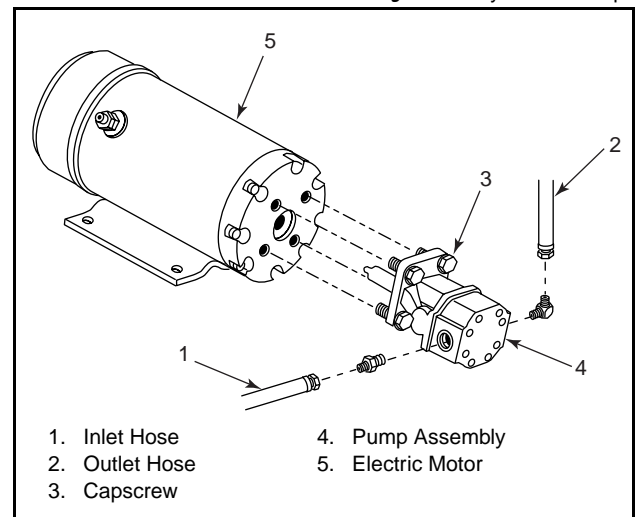

Figure 3-7: Emergency Down Valve

EMERGENCY DOWN VALVE

The Emergency Lowering Valve Knob is located beside the ladder at the rear of the machine.

Open the Emergency Lowering Valve by pulling and holding the knob.

To close, release the knob. The platform will not elevate if the Emergency Lowering Valve is open.

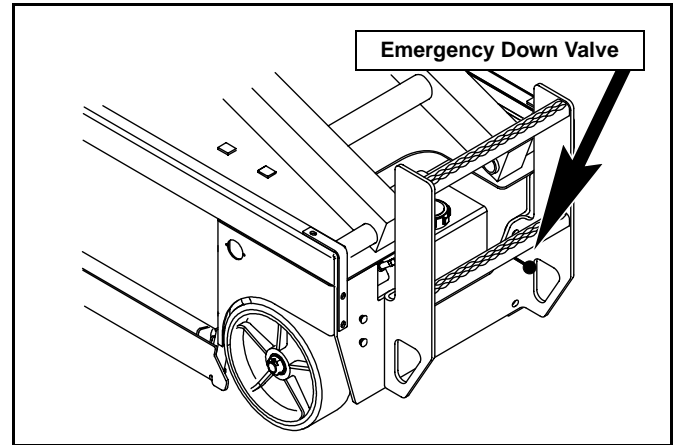

Proximity Switch

The Proximity Switch cuts power to the High Speed Drive when the platform is elevated. The switch is located on the left side of the chassis at the rear of the machine.

No adjustment of the switch should be necessary.

Level Sensor

INTRODUCTION

The Level Sensor has three wires: red-power (24 v in), black-ground, white-output (24 v out). To verify that the sensor is working properly, there is one LED under the sensor that indicates the sensor is off level.

ADJUSTMENT

1. Place the machine on a firm level surface $\pm 1/4^\circ$.
2. Use the Inclinator (P/N: 010119-000) to ensure front and rear of chassis is level $\pm 1/4^\circ$.
3. Adjust the three leveling locknuts until the bubble is centered in the circle on the attached bubble level.

TEST

Raise the platform approximately 7 feet, then push the level sensor to the side. The red LED should turn on, and the tilt alarm should sound.

LEVEL SENSOR (M/C NUMBER 51250+)

These units are sealed and pre-set, and require no recalibration or adjustment.

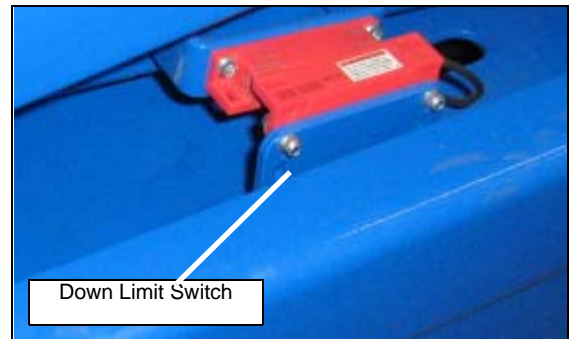

MAIN HYDRAULIC MANIFOLD

Though it is not necessary to remove the manifold to perform all maintenance procedures, a determination should be made prior to beginning as to whether or not the manifold should be removed before maintenance procedures begin.

Figure 3-8: Hydraulic Manifold,

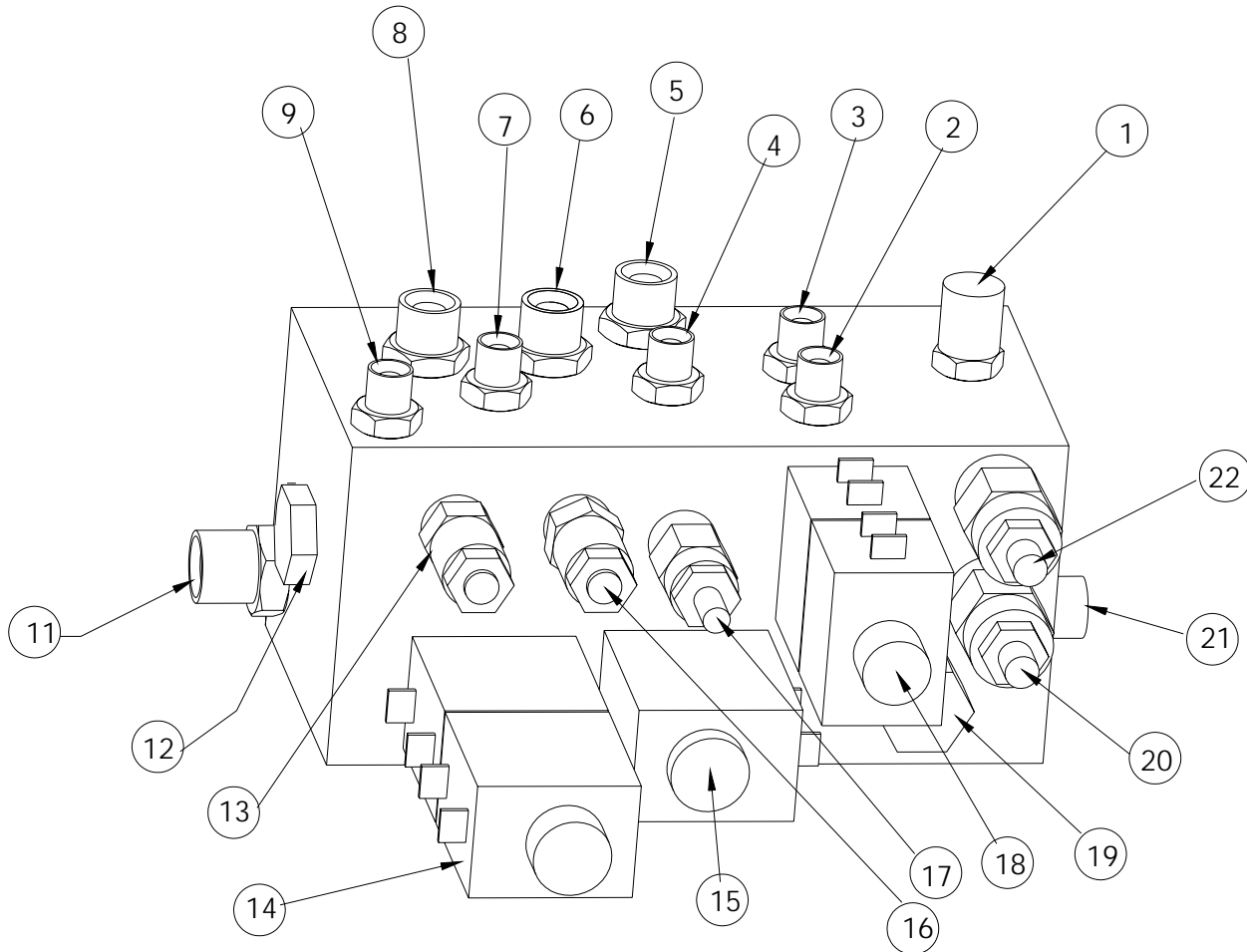

- | | |
|---|-------------------------------------|
| 1. TEST PORT (1/4") | 12. CHECK VALVE (POTHOLE) |
| 2. FITTING (1/4" - 1/4" MALE/MALE) | 13. CROSS LINE RELIEF VALVE (DRIVE) |
| 3. FITTING (1/4" - 1/4" MALE/MALE) | 14. SOLENOID VALVE (DRIVE)) |
| 4. FITTING (1/4" - 1/4" MALE/MALE) | 15. SOLENOID VALVE (DRIVE/LIFT) |
| 5. FITTING (3/8" - 3/8" MALE/MALE) | 16. CROSS LINE RELIEF VALVE (DRIVE) |
| 6. FITTING (3/8" - 3/8" MALE/MALE) | 17. PRESSURE RELIEF (MAIN LIFT) |
| 7. FITTING (1/4" - 1/4" MALE/MALE WITH 1mm OROFICE) | 18. SOLENOID VALVE (STEERING) |
| 8. FITTING (3/8" - 3/8" MALE/MALE) | 19. FLOW RESTRICTOR (STEERING) |
| 9. FITTING (1/4" - 1/4" MALE/MALE) | 20. RELIEF VALVE (STEERING) |
| 10. - | 21. FITTING (3/8" - 3/8" MALE/MALE) |
| 11. FITTING (1/2" - 1/2" MALE/MALE) | 22. RELIEF VALVE (MAIN) |

SETTING HYDRAULIC MANIFOLD PRESSURES

⚠ WARNING ⚠

The hydraulic oil may be of sufficient temperature to cause burns. Wear safety gloves and safety glasses when handling hot oil.

The oil in the hydraulic system is under very high pressure which can easily cause severe cuts. **Obtain medical assistance immediately if cut by hydraulic oil.**

NOTE: Check the hydraulic pressures whenever the pump, manifold or relief valves have been serviced or replaced

MAIN RELIEF VALVE

1. Operate the hydraulic system 10 to 15 minutes to warm the oil.
2. Remove the cap or loosen the locknut on the Main Relief Valve.
3. Install a 0-207 bar (**0-3000 psi**) pressure gauge to the gauge port.
4. Turn the Chassis Keyswitch to CHASSIS and elevate the machine fully.
5. While holding the Chassis Lift Switch to the UP position, adjust the Main Relief Valve until the pressure gauge reads 165 bar (**2400 psi**).
6. Release the Chassis Lift Switch.
7. Replace the cap, or tighten the locknut on the Lift Relief Valve, and torque to 8N-m (**6 ft-lbs**).
8. Lower the platform.

Figure 3-9: Hydraulic Manifold

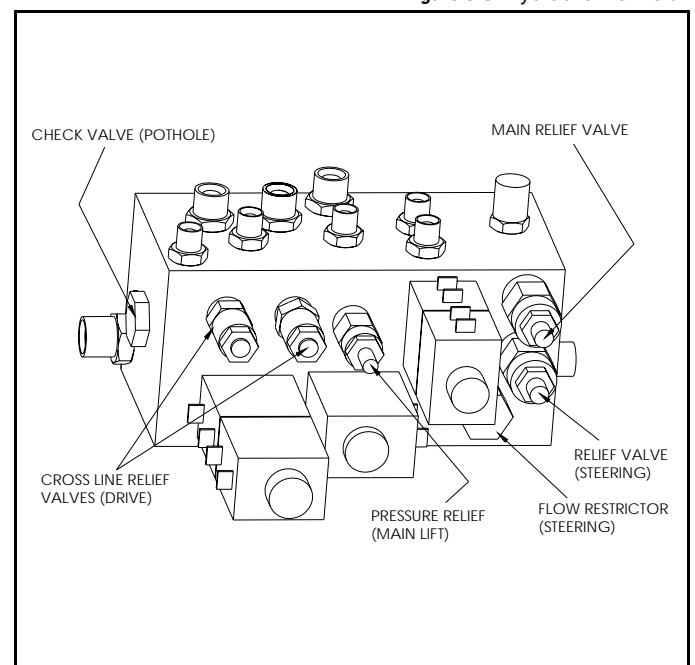

COUNTERBALANCE VALVES

1. Operate the work platform for 10-15 minutes to bring the hydraulic oil up to normal operating temperature.
2. Remove the gauge port cap and install the pressure gauge assembly.
3. Lift work platform and block front wheels off ground.
4. Loosen the locknuts on Counterbalance Valves.
5. With the machine fully powered up depress the **DRIVE** button on the upper control box, depress the interlock lever and slowly pull the control lever to **REVERSE** to drive the wheels.
6. Adjust the Forward Counterbalance Valve by turning the adjustment screw until the pressure gauge indicates 83 bar (**1200 psi**).
7. Slowly push the Control Lever to **FORWARD** to drive the wheels.
8. Adjust the Reverse Counterbalance Valve by turning the adjustment screw until the pressure gauge indicates 83 bar (**1200 psi**).
9. Check the settings by slowly moving the Control Lever **FORWARD**, then **REVERSE**, checking the gauge to ensure pressures are properly set. Re-adjust as needed.
10. Tighten locknuts on valves to 8N-m (**6 ft-lbs**). Remove blocks and lower work platform to ground.
11. Reconnect the red Control Cable wire to terminal #9.
12. Remove the gauge from the gauge port and re-install cap.
13. Check for proper operation of the drive system and brake.

STEERING RELIEF VALVES

1. Operate the work platform for 10-15 minutes to bring the hydraulic oil up to normal operating temperature.
2. Install gauge in the gauge port.
3. Loosen locknut or remove cover on the Steering Relief Valve and turn adjusting screw counter-clockwise two full turns.
4. While one person holds the Steering Switch to steer right or left, slowly turn the Steering Relief Valve adjusting screw clockwise to increase the pressure until the gauge reads 69 bar (**1000 psi**).
5. Tighten locknut or replace Steering Relief Valve cover and torque to 8N-m (**6 ft-lbs**).
6. Remove gauge and replace cap.

3-8 CYLINDERS

DEPRESSION CYLINDER

Figure 3-10: Depression Cylinder Remove & Replace

REMOVAL

1. Mark and disconnect the hose assemblies from the cylinder fittings and immediately cap the openings to prevent foreign material from entering.
2. Place a support under the depression guard.
3. Remove the circlips from the pivot pins.
4. Remove the pivot pins while supporting the cylinder.
5. Remove the cylinder.

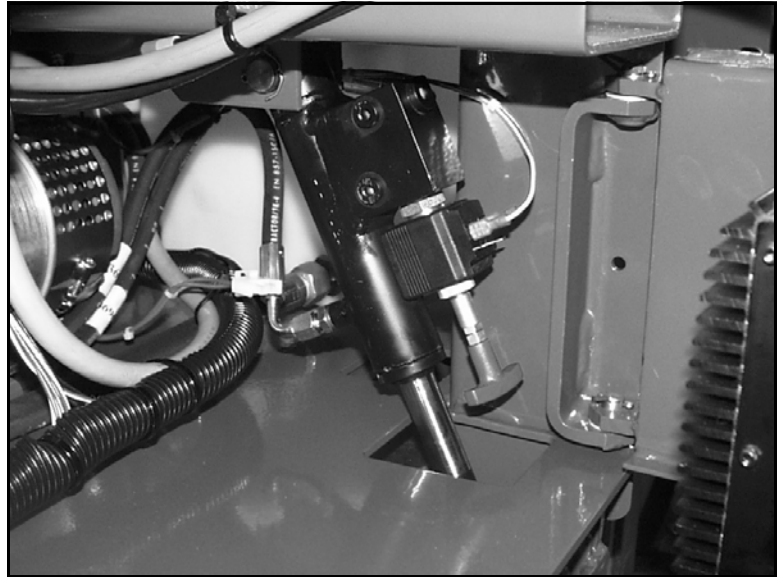

REPAIR

Disassembly

1. Unscrew the head cap from the barrel, removing the head cap, piston, and shaft assembly from the barrel tube.
2. Unscrew the piston.
3. Remove all rod wipers, U-cups, O-rings, and backup rings from the headcap, and discard.
4. Remove the piston ring and O-ring from the piston, and discard.

Cleaning and Inspection

1. Wash all the metal parts in cleaning solvent and blow dry with filtered compressed air.
2. Inspect all the threaded components for stripped or damaged threads.
3. Check the inside surface of the cylinder barrel for scoring or excessive wear.
4. Check the piston and headcaps for scoring or excessive wear.
5. Inspect the surface of the shaft for scoring or excessive wear.

Assembly

1. Lubricate and install new rod wiper, U-cup, O-ring, and backup ring on the headcaps.
2. Install the headcap onto the shaft.
3. Install the new piston rings and O-ring on the piston. Re-install the piston.
4. Lubricate the piston seal with clean hydraulic fluid and install the shaft assembly in the cylinder barrel.
5. Install the head cap into the cylinder barrel, and tighten the head caps.

INSTALLATION

Installation is reverse of removal.

STEERING CYLINDER

REMOVAL

1. Mark and disconnect the hose assemblies from the cylinder fittings and immediately cap the openings to prevent foreign material from entering.
2. Remove the cotter pins from the pivot pins.
3. Remove the pivot pins while supporting the cylinder. Remove the cylinder.

REPAIR

Disassembly

1. Unscrew the head cap from the barrel, removing the head cap, piston, and shaft assembly from the barrel tube.
2. Unscrew the piston.
3. Remove all rod wipers, U-cups, O-rings, and backup rings from the headcap, and discard.
4. Remove the piston ring and O-ring from the piston, and discard.

Cleaning and Inspection

1. Wash all the metal parts in cleaning solvent and blow dry with filtered compressed air.
2. Inspect all the threaded components for stripped or damaged threads.
3. Check the inside surface of the cylinder barrel for scoring or excessive wear.
4. Check the piston and headcaps for scoring or excessive wear.
5. Inspect the surface of the shaft for scoring or excessive wear.

Assembly

1. Lubricate and install new rod wiper, U-cup, O-ring, and backup ring on the headcaps.
2. Install the headcap onto the shaft.
3. Install the new piston rings and O-ring on the piston. Re-install the piston.
4. Lubricate the piston seal with clean hydraulic fluid and install the shaft assembly in the cylinder barrel.

Install the head cap into the cylinder barrel, and tighten the head caps.

Figure 3-11: Steering Cylinder Remove & Replace

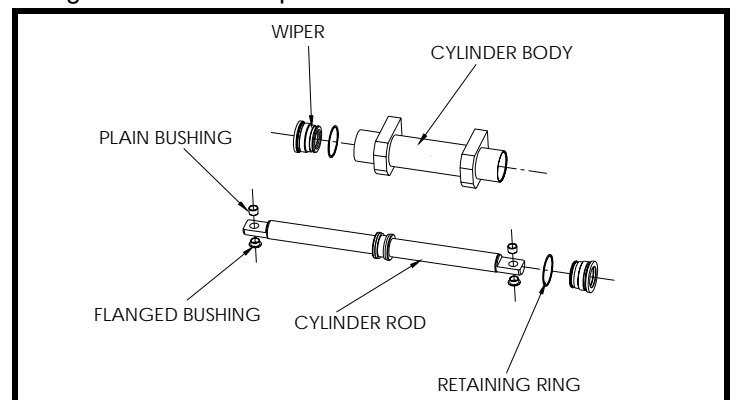
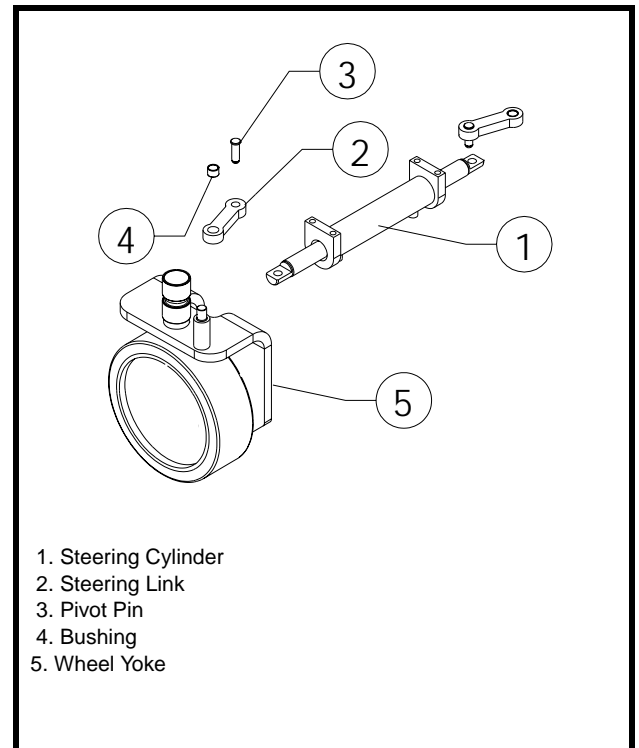

INSTALLATION

1. Position the cylinder assembly in the chassis and insert pivot pins and secure with new cotter pins.
2. Connect the hose assemblies to the fittings.
3. Operate the steering circuit several times throughout its entire range of travel to expel trapped air and check for leaks.

LIFT CYLINDER

REMOVAL

Refer to Figure 0-14: "Elevating Assembly," on page Section 3-18 for details.

1. Provide a suitable container to catch the hydraulic fluid, then disconnect the hydraulic hoses. Immediately plug hoses to prevent foreign material from entering.
2. Remove emergency lowering valve cable and down valve wires from the emergency lowering/down valve.
3. Remove the cable bracket from the lift cylinder.
4. Remove capscrews and locknuts securing lift cylinder pivot pins.
5. Remove lower pivot pin and lower cylinder to rest on chassis.
6. Attach a suitable hoisting device and sling to the cylinder, and remove upper pivot pin.
7. Carefully remove cylinder.

REPAIR

Refer to Pothole / Steering Cylinder Repair on Page 14 & 15.

INSTALLATION

1. Coat both pivot pins with anti-seize compound.
2. Attach a suitable hoisting device and sling to the cylinder. Carefully position cylinder in the elevating assembly, and install the upper pivot pin.
3. Install the capscrew and locknut.
4. Carefully lift the cylinder and align the lower mount, and install the pivot pin. Install the capscrew and locknut securing the pivot pin.
5. Install the cable bracket. Connect the emergency lowering valve cable and down valve wires.
6. Unplug hydraulic hoses and attach to the cylinder.
7. Replace hydraulic fluid removed from lift cylinder.
8. Test with weight at rated Platform load to check system operation. Check for leaks

Figure 3-12: Lift Cylinder Seal Kit

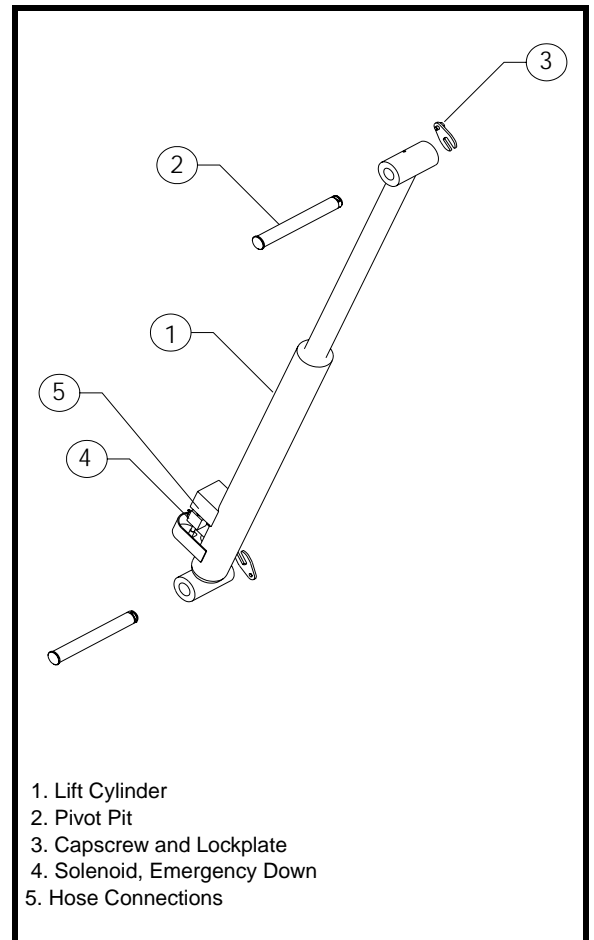

3-9 DRIVE MOTORS

REMOVAL

1. Use a 1000Kg (**one ton**) capacity jack to raise the front of the machine. Position blocks under the machine to prevent the work platform from falling if the jack fails.
2. Block the rear wheels to prevent the machine from rolling.
3. Remove the cotter pin, nut, and washer.
4. Remove the wheel.

NOTE: Before disconnecting hoses, thoroughly clean off all outside dirt around fittings. (After disconnecting hoses and before removing from vehicle, IMMEDIATELY plug port holes.)

5. Tag, disconnect and plug the hose assemblies to prevent foreign material from entering.
6. Support the drive motor/wheel yoke assembly and remove the retaining ring at the top of the wheel yoke pivot. Remove the drive motor/wheel assembly from the machine.
7. Remove the locknuts, flat washers, capscrews and drive motor from the wheel yoke.

INSTALLATION

1. Position the drive motor in the wheel yoke and secure with capscrews, flat washers and locknuts.
2. Install the drive motor/wheel yoke assembly into the pivot bearing along with the lower thrust washer, thrust bushing, and retaining ring.
3. Align the steer pin with the hole in the steering link.
4. Remove the plugs from the hose assemblies and connect to the drive motor.
5. Install the shaft key, wheel, washer and slotted nut. Torque the locknut to 102 N-m (**75 ft-lbs**). Install a new cotter pin. **DO NOT** back-off the nut to install cotter pin.
6. Remove blocks, lower the jack and remove. Operate the drive system and check for leaks.

Figure 3-13: Drive Motor Assembly

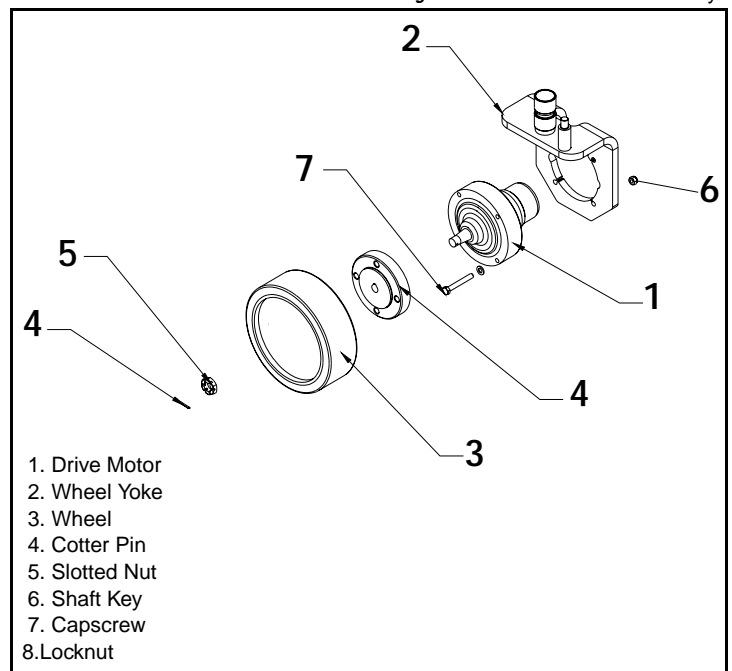

3-10 CONTROLS

PLATFORM CONTROLS

The Proportional Controller can be disassembled to replace defective switches. See the Parts Manual for replacement part numbers.

Figure 3-14: Upper Controls

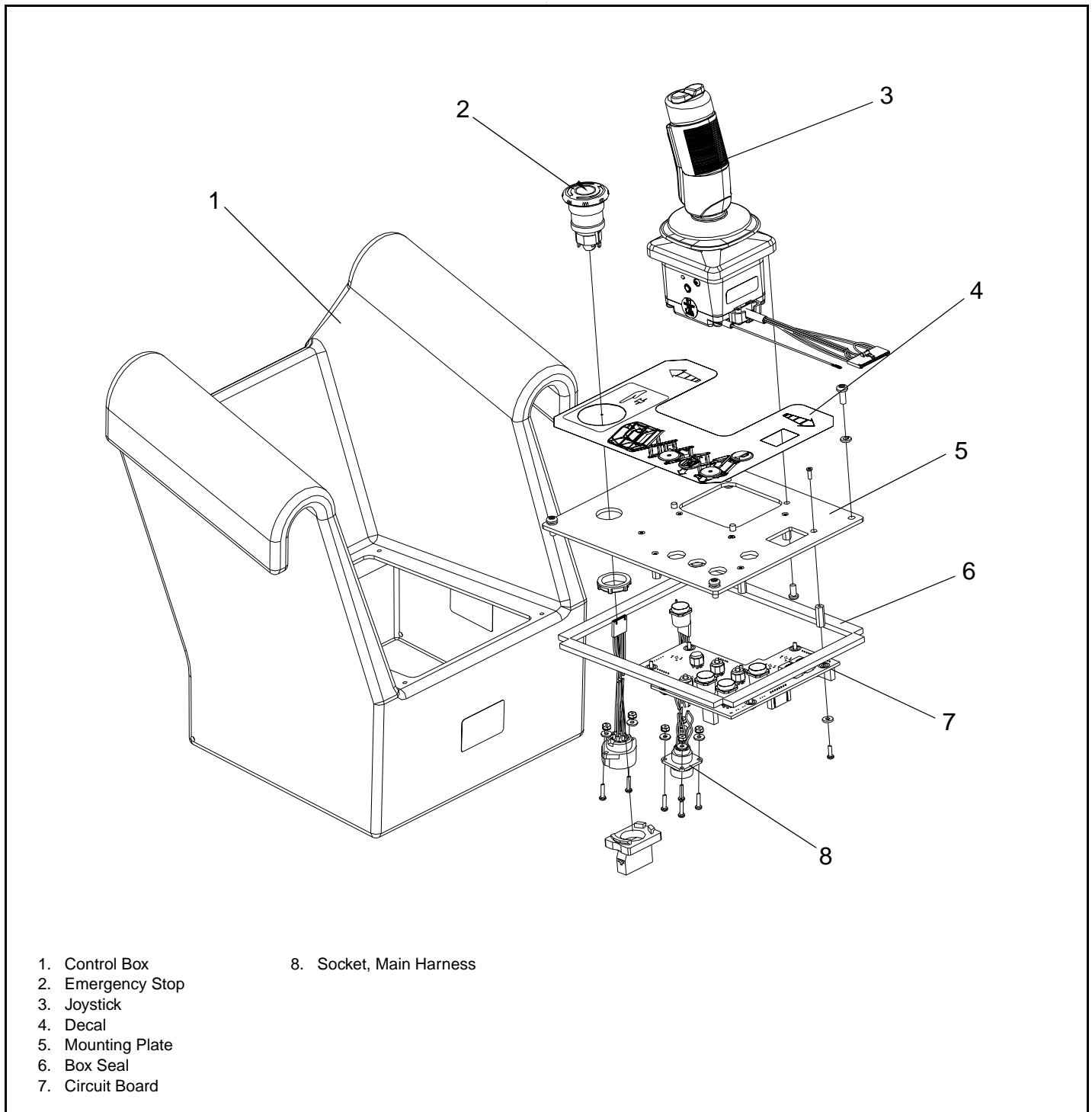

CHASSIS CONTROLS

The chassis control assembly is mounted on the inside of the chassis door, to the left of the Hydraulic tank.

Figure 3-15: Chassis Controls

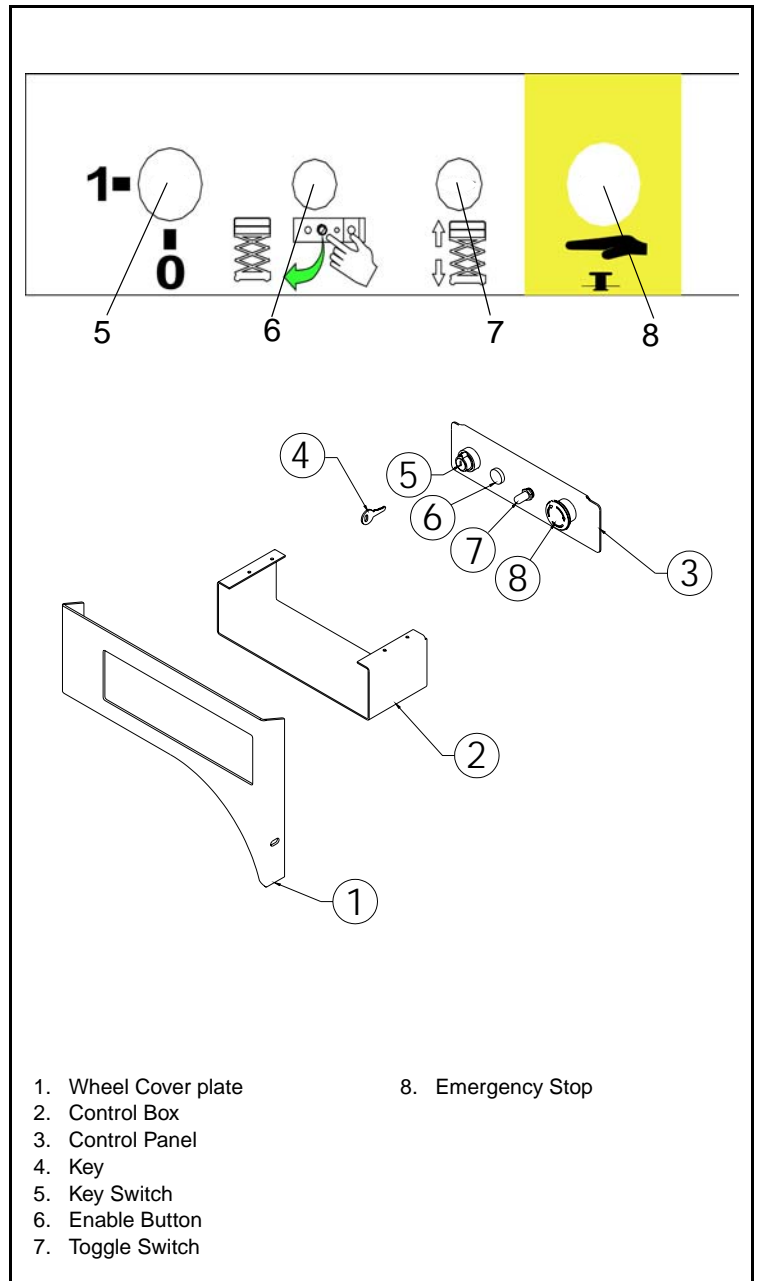

TROUBLESHOOTING

4.1 INTRODUCTION

The following section on troubleshooting provides guidelines on the types of problems users may encounter in the field, helps determine the cause of problems, and suggests proper corrective action.

Careful inspection and accurate analysis of the symptoms listed in the Troubleshooting Guide will localize the trouble more quickly than any other method. This manual cannot cover all possible problems that may occur. If a specific problem is not covered in this manual, call our number for service assistance.

Referring to Section 2.0 and 5.0 will aid in understanding the operation and function of the various components and systems and help in diagnosing and repair of the machine.

GENERAL PROCEDURE

Thoroughly study hydraulic and electronic schematics in **Section 5**. Check for loose connections and short circuits. Check/repair/replace each component in the Truth Table that is listed under each machine function that does not operate properly.

Use the charts on the following pages to help determine the cause of a fault.

NOTE: Spike protection diodes at components have been left out of the charts to eliminate confusion.

W A R N I N G

When troubleshooting, ensure that the work platform is resting on a firm, level surface.

When performing any service that requires the platform to be raised, ensure that the platform and booms are supported by a crane capable of supporting the load.

Unplug the machine or disconnect the battery when replacing or testing the continuity of any electrical component.

4.2 TROUBLESHOOTING

1. Verify your problem.
 - Do a full function test from both the platform and chassis controls, and note all functions that are not operating correctly.
2. Narrow the possible causes of the malfunction.
 - Use the troubleshooting guide to determine which components are common to all circuits that are not functioning correctly.
3. Identify the problem component.
 - Test components that are common to all circuits that are not functioning correctly. Remember to check wires and terminals between suspect components. Be sure to check connections to battery negative.
4. Repair or replace any component found to be faulty.
5. Verify that repair is complete.
 - Do a full function test from both the platform and chassis controls to verify that all functions are operating correctly and that the machine is performing to specified values.

SPECIAL TOOLS

Following is a list of tools which may be required to perform certain maintenance procedures on the MX19 work platforms.

- Flow Meter with Pressure Gauge (**UpRight** P/N 067040-000)
- 0-69 bar (0-1000 psi) Hydraulic Pressure Gauge with Adapter Fittings (**UpRight** P/N 014124-010)
- 0-207 bar (0-3000 psi) Hydraulic Pressure Gauge with Adapter Fittings (**UpRight** P/N 014124-030)
- Adapter Fitting (**UpRight** P/N 063965-002)
- Inclinator (**UpRight** P/N 010119-000)
- Crimping Tool (**UpRight** P/N 028800-009)
- Terminal Removal Tool (**UpRight** P/N 028800-006)

ADJUSTMENT PROCEDURES

Hydraulic settings must be checked whenever a component is repaired or replaced.

Remove counterbalance valves and "bench test" them if they are suspect.

Connect a pressure gauge of appropriate range to the test port located on the hydraulic manifold.

Correct pressure settings are listed in the hydraulic schematic.

CHECKING PUMP PRESSURES

Remove hose from pump port and connect pressure gauge.

4.3 TROUBLESHOOTING GUIDE

TROUBLE	PROBABLE CAUSE	REMEDY
All functions inoperable, electric motor does not start.	<ol style="list-style-type: none"> 1. Blown electric motor fuse 2. Faulty battery charger. 3. Faulty battery(ies). 4. Loose or broken battery lead. 5. Emergency Stop switch(es) failed open. 6. Blown control fuse 	<p>Check 160 amp electric motor fuse. Replace if blown.</p> <p>Check the voltage output of the battery charger. If less than 24 VDC,</p> <p>After completely charging batteries, test each battery. Replace as</p> <p>Check continuity of all battery and motor leads. Replace if necessary.</p> <p>With emergency stop switch in the ON position, check continuity</p> <p>Check 7A circuit control fuse. Replace if blown.</p>
All functions inoperable. Electric motor starts when control is actuated.	<ol style="list-style-type: none"> 1. Oil level in hydraulic reservoir is low. 2. Faulty hydraulic pump. 	<p>Check hydraulic fluid level, top off as required.</p> <p>Check pressure and delivery of the hydraulic pump. Replace if</p>
Platform will not elevate or elevates slowly.	<ol style="list-style-type: none"> 1. Emergency Lowering valve open. 2. Platform overloaded. 3. Faulty controller at upper controls. 4. Blown control fuse 5. Battery level low. Check for fault code 68 	<p>Close emergency down valve.</p> <p>Observe maximum load rating. (see Operation section of this manual)</p> <p>Check functionality of controller. Replace if faulty.</p> <p>Check 7A circuit control fuse. Replace if blown.</p> <p>Check Battery Voltage. Charge if necessary.</p>
Platform drifts down after being elevated	<ol style="list-style-type: none"> 1. Emergency lowering valve open. 2. Leaking piston seals in lift cylinders 	<p>Ensure that emergency lowering valve is completely closed. Replace</p> <p>Check for leakage at cylinder return line, replace seals if necessary.</p>

4.4 FAULT CODES INTRODUCTION

The MX19 is equipped with a fault detection system, if you have a faulty component, bad electrical connection or start up error a fault code will be displayed on the read out located on the upper control box.

For fault codes 01 - 39 the following procedure should be followed.

Ensure that no selector buttons are depressed.

Ensure that the deadman switch on the joystick is not held.

Ensure that the joystick is in neutral.

Ensure that the steer rocker is not activated.

Ensure that toggle switch is in neutral.

Then re-cycle power, do this by pushing and releasing the emergency stop button. If the fault code is still displayed you may have a faulty upper or lower control box, consult the error code list to identify the problem component and replace if necessary.

For fault codes 54 - 68 the following procedure should be followed.

1. Check the fault code list to identify the problem component.
2. Ensure that the wiring harness is connected, secure, in good condition and fully intact.
3. Ensure that the problem component is receiving electrical signal, consult the schematics in section 6 of this manual to identify the ECU output and harness test points.
4. If no ECU output is present replace the ECU.
5. If ECU output is present but no signal is reaching the component replace the wiring harness.
6. If signal is reaching the component but the component is not functioning replace the component (refer to section 6 of this manual for part number information).

4.5 FAULT CODES

- 01 – System initialization error
- 02 – System communication error
- 22 – Platform Left Turn Switch ON at power-up
- 23 – Platform Right Turn Switch ON at power-up
- 25 – Platform Hi-Drive Switch ON at power-up
- 27 – Platform Lo-Drive Switch ON at power-up
- 28 – Platform Lift Switch ON at power-up
- 29 – Platform Joystick Enable Switch ON at power-up
- 31 – Platform Joystick not in neutral at power-up
- 32 – Lower Control Up/DownToggle ON at power-up
- 39 – Lower Control Enable Switch ON at power-up

- 54 – Pothole Retract Coil fault
- 55 – Lift Up Coil fault
- 56 – Lift Down Coil fault
- 59 – Steer Right Coil fault
- 61 – Steer Left Coil fault
- 66 – Forward Coil fault
- 67 – Reverse Coil fault

- 68 – Low Battery fault

4-6 ELECTRIC

Table 4-1: Electrical Troubleshooting Table

Component	Function	Lower Controls	Upper Controls	Drive Forward	Drive Reverse	High Speed/Creep	Raise Platform	Lower Platform	Steer Left	Steer Right	Depression Mechanism Extend	Depression Mechanism Retract	Brakes	Tilt Alarm	Down Alarm	Battery Charge
Alarm																
Batteries		X	X	X	X	X	X	X	X	X	X	X	X	X	X	
Battery Charger																X
5 AMP Circuit Breaker		X	X	X	X	X	X	X	X	X	X	X	X	X	X	
175 AMP Fuse		X	X	X	X	X	X	X	X	X	X	X	X			
ECU		X	X	X	X	X	X	X	X	X	X	X	X	X	X	
Motor Control		X	X	X	X	X	X	X	X	X	X	X	X			
Motor				X	X	X	X	X	X	X	X	X	X			
Chassis Emergency Stop Switch		X	X	X	X	X	X	X	X	X	X	X	X	X	X	
Chassis Key Switch		X	X	X	X	X	X	X	X	X	X	X	X	X	X	
Platform Emergency Stop Switch		X	X	X	X	X	X	X	X	X	X	X	X	X	X	
Interlock Switch			X	X	X	X	X	X	X							
PQ Control Handle			X	X	X		X	X								
Height Limit Switch							X									
Platform Steering Switch									X	X						
Tilt Sensor		X	X	X	X	X	X	X	X	X	X	X	X	X	X	
Steering Solenoid (right)										X						
Steering Solenoid (left)									X							
Platform Lift Solenoid							X									
Down Solenoid								X								
Reverse Solenoid					X											
Forward Solenoid				X												

4-7 HYDRAULIC

Table 4-2: Hydraulic Troubleshooting Table

Component	Function	Lift Platform	Lower Platform	Steer Right	Steer Left	Drive Forward	Drive Reverse	Creep	Depression Mechanism Extend	Depression Mechanism Retract	Brakes
Check Valve									X	X	
Steering Cylinder				X	X						
Lift Cylinder		X									
Depression Mechanism Cylinder									X	X	
Brake Cylinder											X
Suction Strainer		X		X	X	X	X	X	X	X	
Return Filter		X		X	X	X	X	X	X	X	
Drive Motors (2)						X	X				
Pump		X		X	X	X	X	X	X	X	
Main Relief Valve		X				X	X	X	X	X	X
Steering Relief Valve				X	X						
Lift Relief Valve		X									
Tank											
Steering Right/Left Valve				X	X						
Lift Valve		X									
Down/Emergency Lowering Valve			X								
Forward/Reverse Valve						X	X				
Counterbalance Valve						X	X	X			X

Notes :

SCHEMATICS

5.1 INTRODUCTION

This section contains electrical and hydraulic power schematics and associated information for maintenance purposes.

The diagrams are to be used in conjunction with the information in **Section 4**.

They allow understanding of the makeup and functions of the systems for checking, tracing, and faultfinding during troubleshooting analysis.

CONTENTS

Schematic (J1 Harness)	5-2
Cable Assembly (J1 Harness)	5-3
Electrical Schematic	5-4
Overload Schematic	5-5
Hydraulic Schematic	5-6

5.2 ELECTRIC

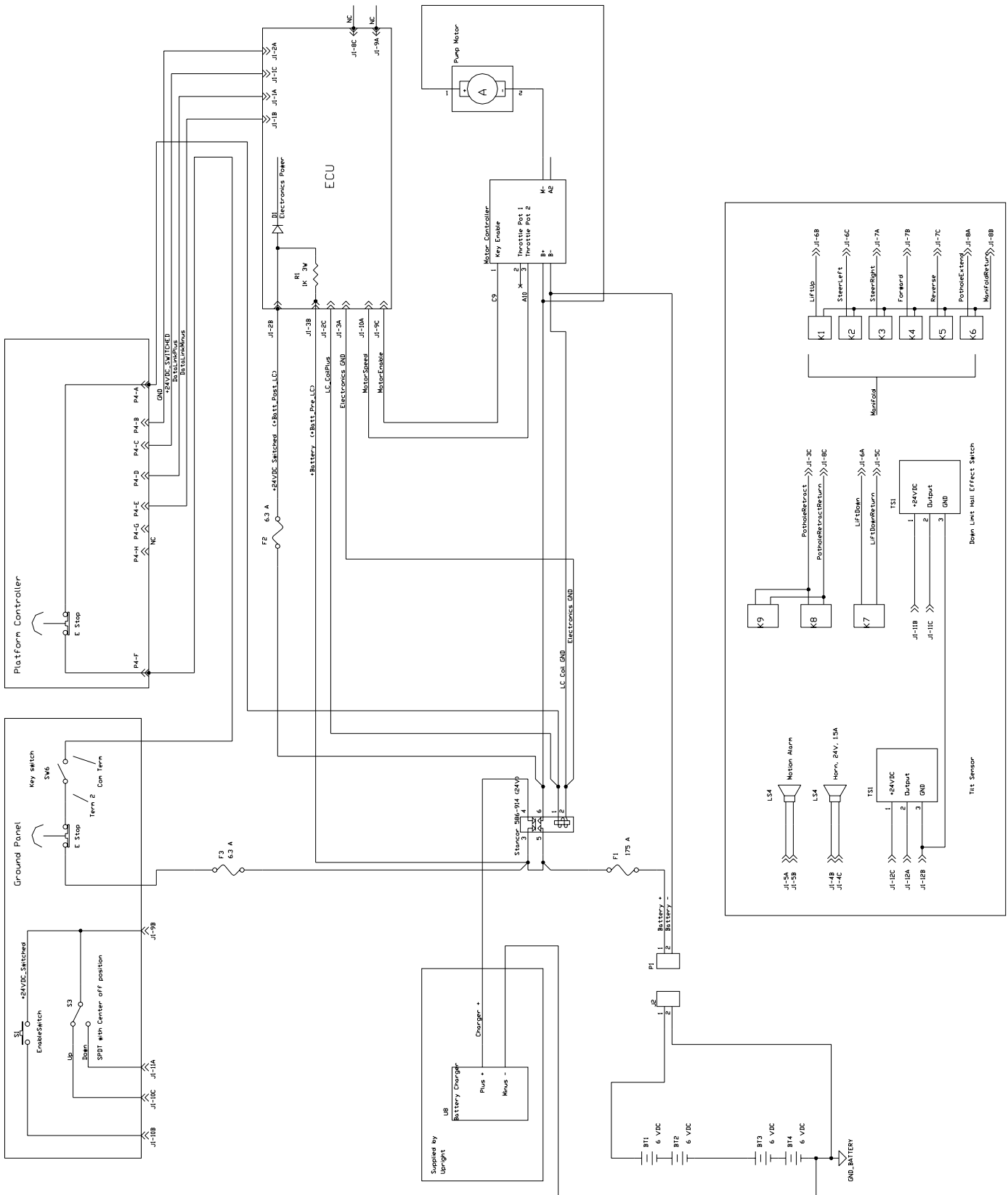

5.3 CABLE ASSEMBLY

WIRE INFORMATION

TABLE 1

ITEM NO.	POSITION	COLOR	LENGTH	ITEM NO.	POSITION	COLOR	LENGTH	ITEM NO.	POSITION	COLOR	LENGTH
1	A1	YELLOW, FROM ITEM 85	1117mm (440")	13	B1	ORANGE, FROM ITEM 85	1117mm (440")	25	C1	BROWN, FROM ITEM 85	1117mm (440")
2	A2	BLACK, FROM ITEM 85	1117mm (440")	14	B2	RED, SINGLE WIRE	258mm (10")	26	C2	WHT, SINGLE WIRE	544mm (21.4")
3	A3	BLACK, SINGLE WIRE	544mm (21.4")	15	B3	BLUE, SINGLE WIRE	544mm (21.4")	27	C3	PINK, FROM ITEM 88c	864mm (34")
4	A4	NOT USED	-----	16	B4	PINK, FROM ITEM 88b	508mm (20")	28	C4	GRAY, FROM ITEM 88b	508mm (20")
5	A5	ORANGE, SINGLE WIRE	924mm (36.4")	17	B5	BLACK, SINGLE WIRE	924mm (36.4")	29	C5	GRAY, FROM ITEM 88b	3810mm (150")
6	A6	PINK, FROM ITEM 88a	3810mm (150")	18	B6	LIGHT BLUE, SINGLE WIRE	750mm (29.5")	30	C6	WHITE/BLUE, SINGLE WIRE	750mm (29.5")
7	A7	WHITE/BLACK, SINGLE WIRE	750mm (29.5")	19	B7	BLUE/BLACK, SINGLE WIRE	750mm (29.5")	31	C7	DRUM, SINGLE WIRE	750mm (29.5")
8	A8	WHITE, SINGLE WIRE	750mm (29.5")	20	B8	BLACK, SINGLE WIRE	750mm (29.5")	32	C8	GRAY, FROM ITEM 88c	864mm (34")
9	A9	NOT USED	-----	21	B9	RED, SINGLE WIRE	1500mm (59")	33	C9	BLACK, SINGLE WIRE	656mm (27.4")
10	A10	RED, SINGLE WIRE	656mm (27.4")	22	B10	BLUE, SINGLE WIRE	1500mm (59")	34	C10	BLUE/PURPLE, SINGLE WIRE	1500mm (59")
11	A11	BLACK/ORANGE, SINGLE WIRE	1500mm (59")	23	B11	PINK #1, FROM ITEM 89a	695mm (27.3")	35	C11	GRAY #2, FROM ITEM 89a	695mm (27.3")
12	A12	GRAY #2, FROM ITEM 89b	495mm (19.5")	24	B12	BLUE #3, FROM ITEM 89b	495mm (19.5")	36	C12	PINK #1, FROM ITEM 89b	495mm (19.5")

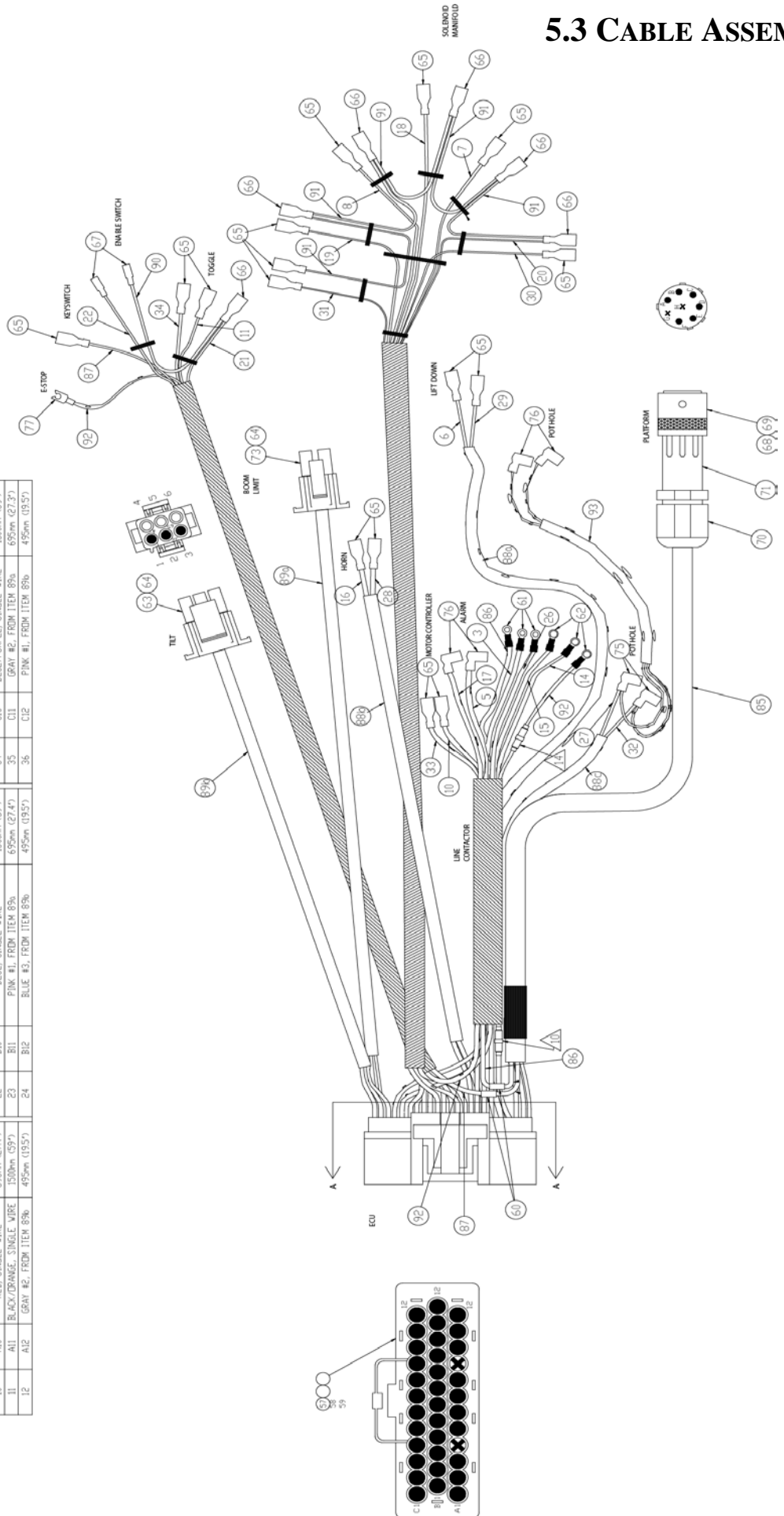

5.4 J1 CABLE SCHEMATIC

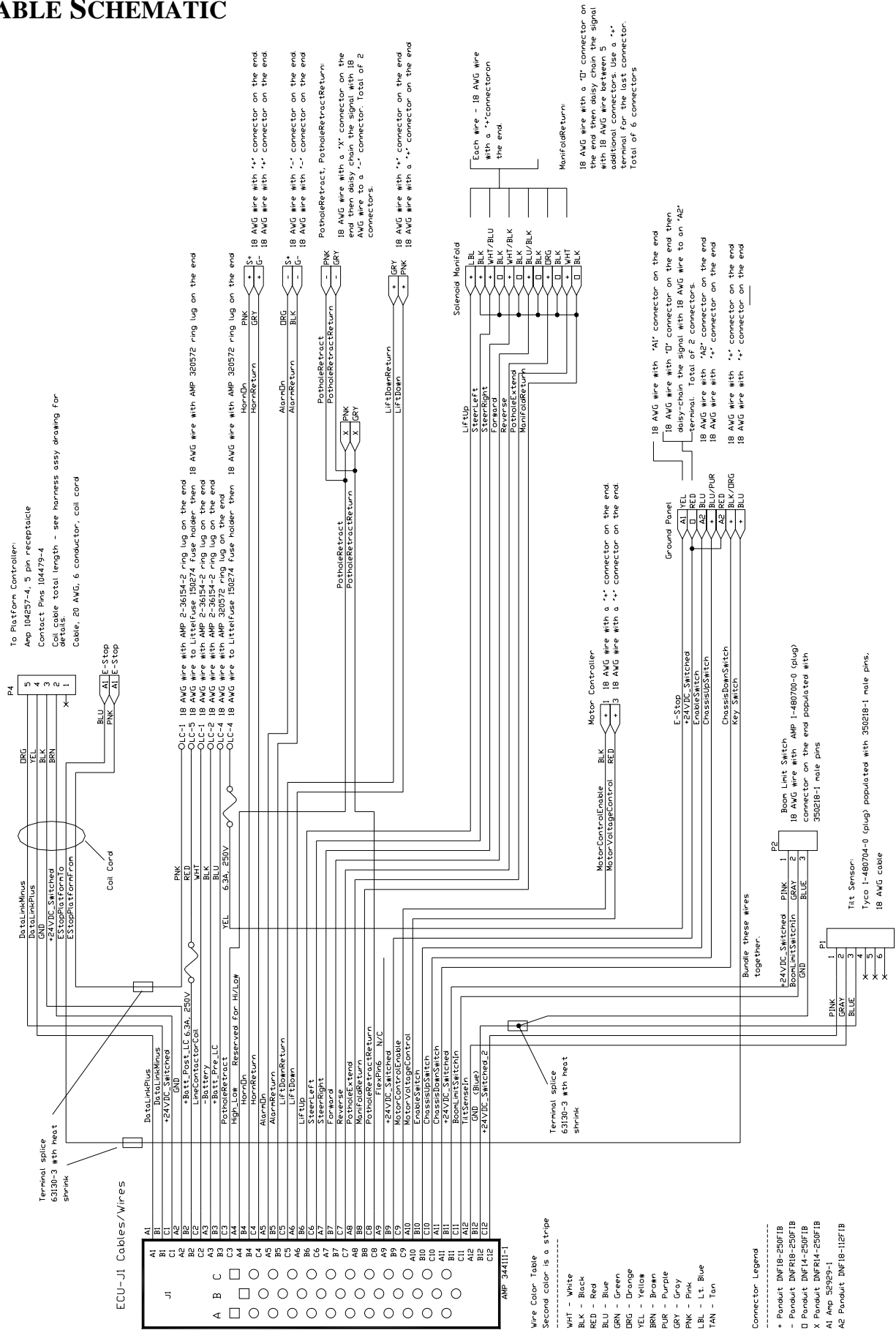

Each wire - 18 AWG wire with a '+' connector on the end. Total of 6 connectors.

18 AWG wire with '+' connector on the end. Total of 6 connectors.

18 AWG wire with '+' connector on the end. Total of 6 connectors.

18 AWG wire with '+' connector on the end. Total of 6 connectors.

18 AWG wire with '+' connector on the end. Total of 6 connectors.

18 AWG wire with '+' connector on the end. Total of 6 connectors.

18 AWG wire with '+' connector on the end. Total of 6 connectors.

18 AWG wire with '+' connector on the end. Total of 6 connectors.

18 AWG wire with '+' connector on the end. Total of 6 connectors.

18 AWG wire with '+' connector on the end. Total of 6 connectors.

18 AWG wire with '+' connector on the end. Total of 6 connectors.

18 AWG wire with '+' connector on the end. Total of 6 connectors.

18 AWG wire with '+' connector on the end. Total of 6 connectors.

18 AWG wire with '+' connector on the end. Total of 6 connectors.

5.5 OVERLOAD SCHEMATIC

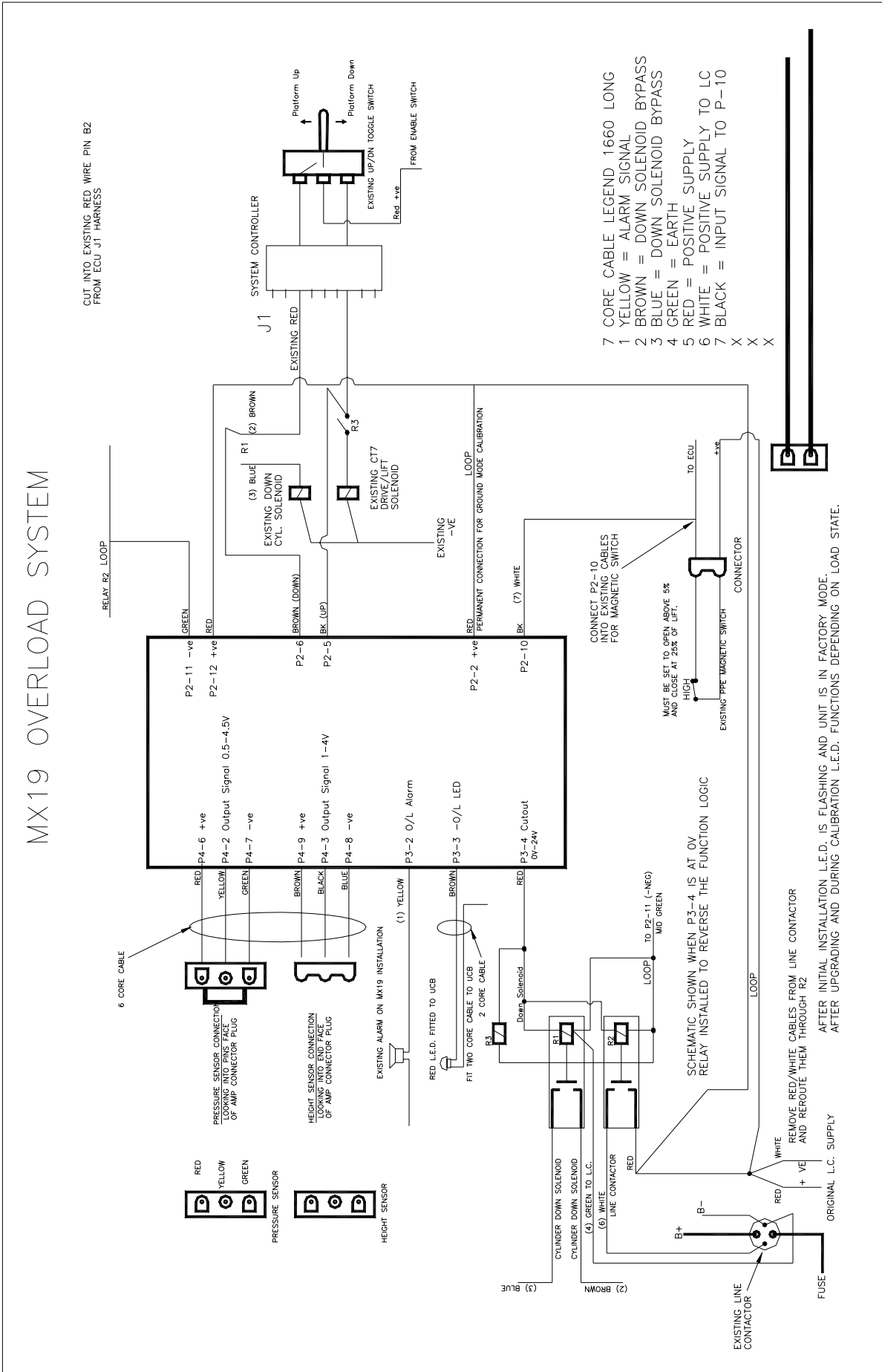

5.6 Hydraulic Schematic

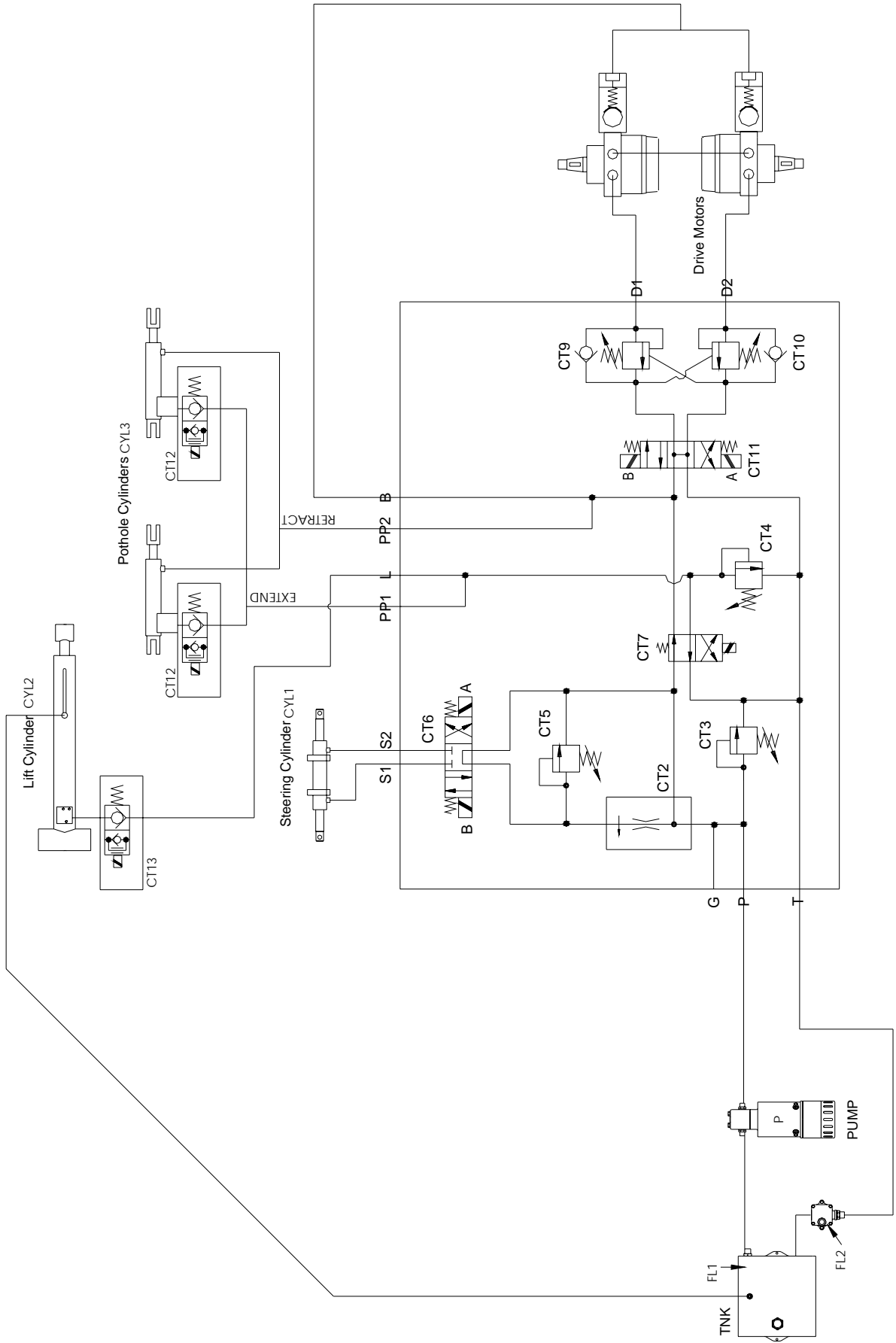

ILLUSTRATED PARTS BREAKDOWN

6.1 INTRODUCTION

This section lists and illustrates the replaceable assemblies and parts of this product, as manufactured by **UpRight**

Each parts list contains the component parts for that assembly.

CONTENTS

General Assembly	6 - 2	Hydraulic Assembly	6 - 15
Motor Mount Assembly	6 - 3	Hydraulic Cylinder Assembly (Lift)	6 - 17
Chassis Assembly	6 - 4	Hydraulic Cylinder Assembly (Steer)	6 - 18
Scissor Assembly	6 - 6	Hydraulic Cylinder Assembly (Pothole)	6 - 19
Platform Assembly	6 - 8	Electrical Assembly	6 - 20
Rear Wheel Assembly	6 - 10	Overload Assembly	6 - 21
Control Valve Assembly	6 - 11	Decal Kit (English)	6 - 22
Lower Controls Assembly	6 - 12	Decal Kit (German)	6 - 23
Hydraulic Tank Assembly	6 - 13	Decal Kit (French)	6 - 23
Upper Controls Assembly	6 - 14	Decal Kit (USA)	6 - 24

General Assembly

503500-020

Item	Part	Description	QTY.
1	503501-000	CHASSIS ASSEMBLY	1
2	065705-030	SCISSOR ASSEMBLY	1
3	503503-000	PLATFORM ASSEMBLY	1
4	503507-000	HYDRAULIC ASSEMBLY	1
5	503508-000	ELECTRICAL ASSEMBLY	1

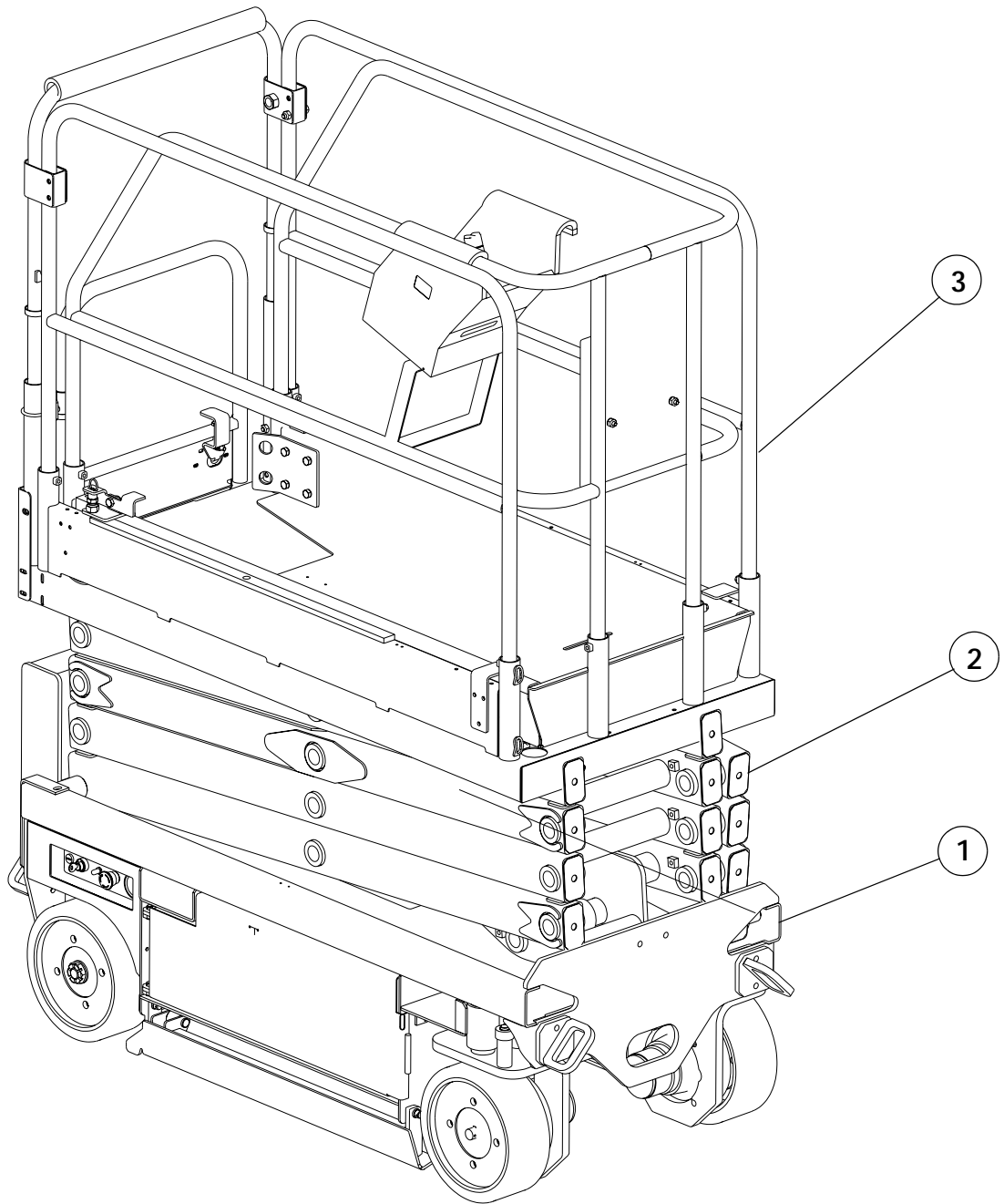

Motor Mount Assembly

503511- 001

1	113063-000	MOTOR MOUNT WELDMENT (RH)	1
2	113064-000	MOTOR MOUNT WELDMENT (LH)	1
3	503678-001	DRIVE MOTOR	2
5	504350-000	WHEEL	2
6	502152-000	SPLIT PIN	2
7	503755-000	CASTLE NUT	2
8			
9			
10	057052-090	HEX HEAD BOLT (M12 X 90)	8
11	056069-012	WASHER (M12)	8
12	056066-012	NYLOCK NUT (M12)	8
13	066183-001	BUSHING, OILITE	2

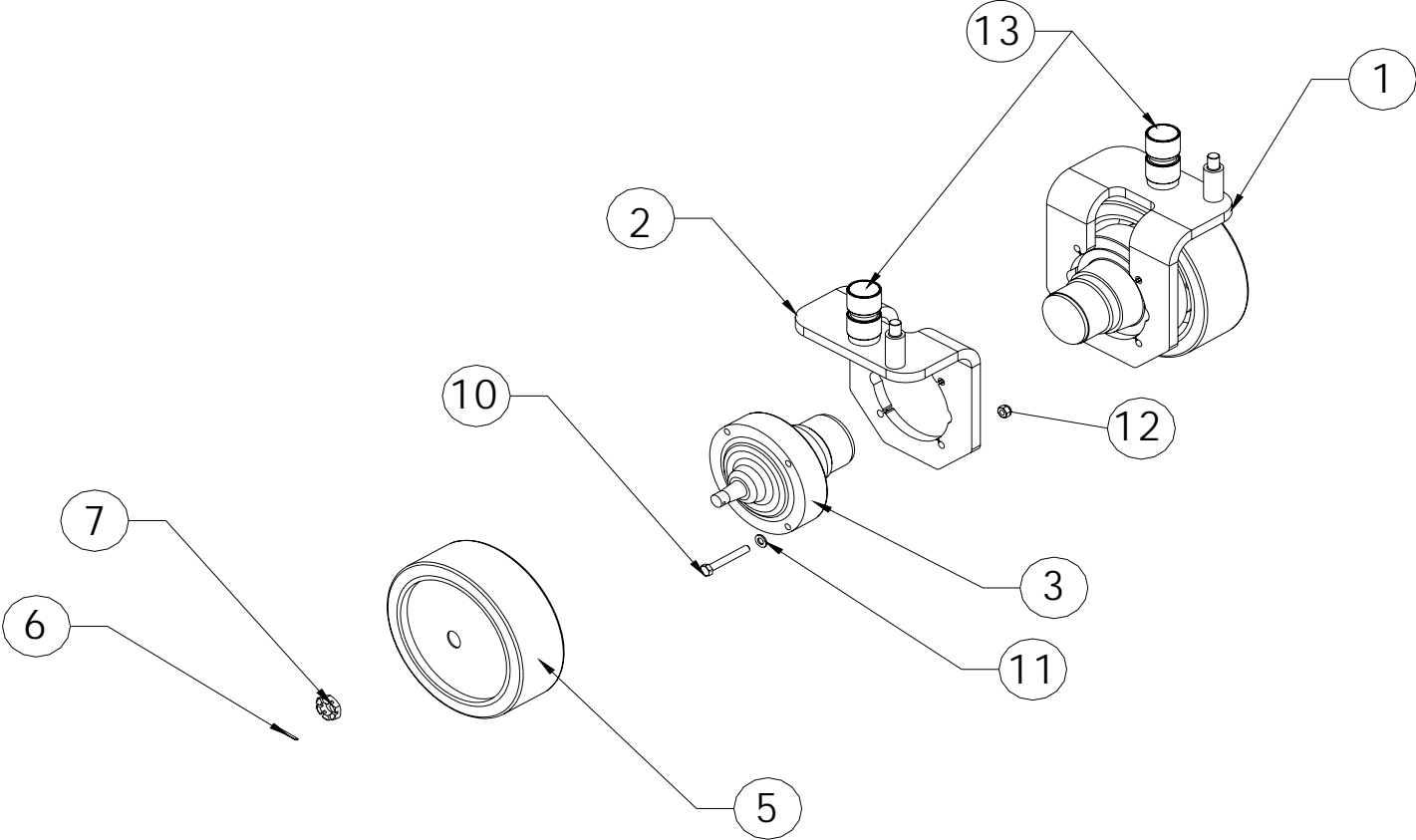

Chassis Assembly

503501-000

1	065620-025	CHASSIS	1
2	503696-000	HYDRAULIC TANK ASSEMBLY	1
3	066307-005	LADDER WELDMENT	1
4	065971-021	POTHOLE BAR (RH)	1
5	065971-020	POTHOLE BAR (LH)	1
6	065650-001	CHASSIS DOOR (RH)	1
7	065657-002	CHASSIS DOOR (LH)	1
8	057082-000	CLAMP BOLT ASSEMBLY	2
9	503511-001	MOTOR MOUNT ASSEMBLY (RH)	1
10	503511-000	MOTOR MOUNT ASSEMBLY (LH)	1
11	503609-001	WHEEL COVER WELDMENT (MAIN PLATE)	1
12	503686-000	TIE DOWN RING	1
13	503686-001	TIE DOWN RING	1
14	503687-000	CYLINDER, HYDRAULIC (STEERING)	1
15	503622-000	CYLINDER, HYDRAULIC (POTHOLE)	2
16	503755-000	CASTLE NUT 1 1/8	2
17	502152-000	SPLIT PIN	2
18	503677-000	PLAIN WASHER	2
19	504351-001	WHEEL	4
20	504157-000	ROLLER BEARING	2
21	503673-000	PLAIN BUSHING	8
22	503672-000	PLAIN BUSHING	8
23	011848-019	PIVOT PIN (POTHOLE CYLINDER, BODY END)	2

24	011848-036	PIVOT PIN (POTHOLE CYLINDER, ROD END)	2
25	503760-000	PLAIN BUSHING	2
26	503676-000	DU WASHER	4
27	069199-001	BATTERY CHARGER	1
28	501074-000	BATTERY (6V 220ah , T605)	4
29	504536-000	PUMP MOTOR	1
30	-	PUMP	1
31	502139-001	BATTERY ANGLE	2
32	058912-000	TILT SENSOR SWITCH	1
33	503679-000	SLIDE, BATTERY COMPARTMENT	4
34	503800-001	MANIFOLD, HYDRAULIC	1
35	502483-000	ECU	1
36	502492-000	MOTOR CONTROLLER	1
37	503609-000	REAR MUDGUARD (LH)	1
38	503681-000	STOP BRACKET	2
39	503626-001	STEERING LINK PLATE	2
40	501227-002	PIVOT PIN, STEERING CYLINDER	2
41	503757-000	SUPPORT PLATE, PCB	1
42	502494-000	FUSE 175A	1
43	501877-000	FUSE HOLDER	2
44	056066-004	NYLOCK NUT, M4 - 8	1
45	503758-000	ADAPTOR PLATE, FUSE	1
46	503759-000	LATCH SPACER, BATTERY	2

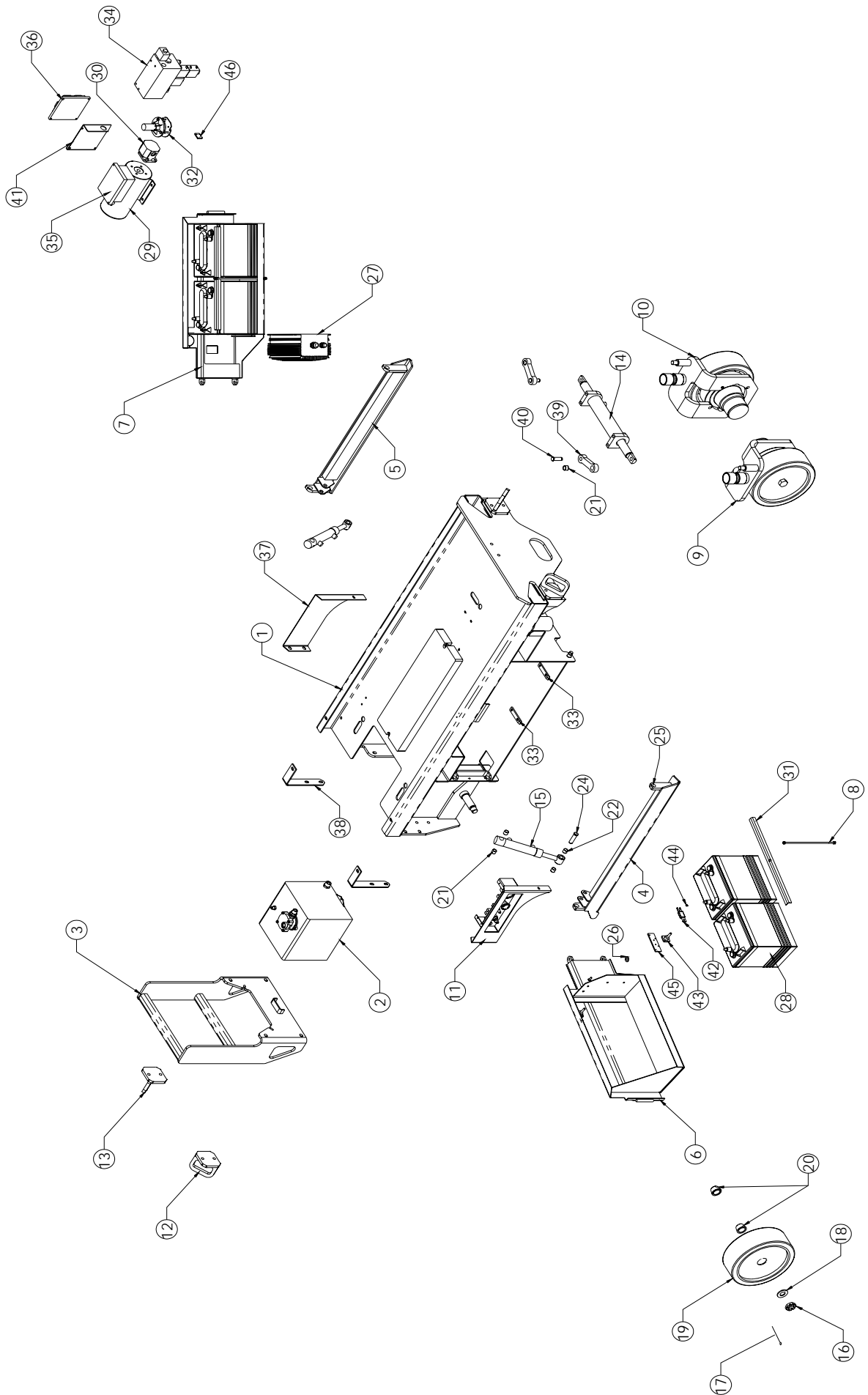

Scissor Assembly

065705-030

ITEM	PART NUMBER	DESCRIPTION	QTY.
1	509524-000	INNER ARM WELDMENT	1
2	065671-001	OUTER BEAM WELDMENT RH	2
3	065672-001	OUTER BEAM WELDMENT LH	2
4	065677-001	INNER CENTER BEAM WELDMENT	1
5	065675-002	OUTER CENTER BEAM WELDMENT	4
6	065722-001	INNER ARM WELDMENT X19	1
7	065721-001	UPPER BEAM WELDMENT X9	1
8	503795-050	LIFT CYLINDER MX19	1
	503795-010	SEAL KIT, LIFT CYLINDER	
9	MB4040DU	BEARING BUSH	40
10	065696-001	CYLINDER PIN WELDMENT	1
11	065750-001	CYLINDER PIN WELDMENT X19	1
12	065688-001	RIVET	2
13	065687-000	CABLE GUIDE	1
14	065920-001	PIVOT PIN WELDMENT	18
15	065697-001	PIN KEEPER WELDMENT	2
16	502176-000	CLAMP	5
17	058503-075	M8 X 75 SHCS	20
19	105308-002	M8 LOCKNUT	20
20	058504-075	M10 X 75 BOLT	2
21	056064-010	10 LOCKNUT	2
22	056064-006	M6 LOCKNUT	1

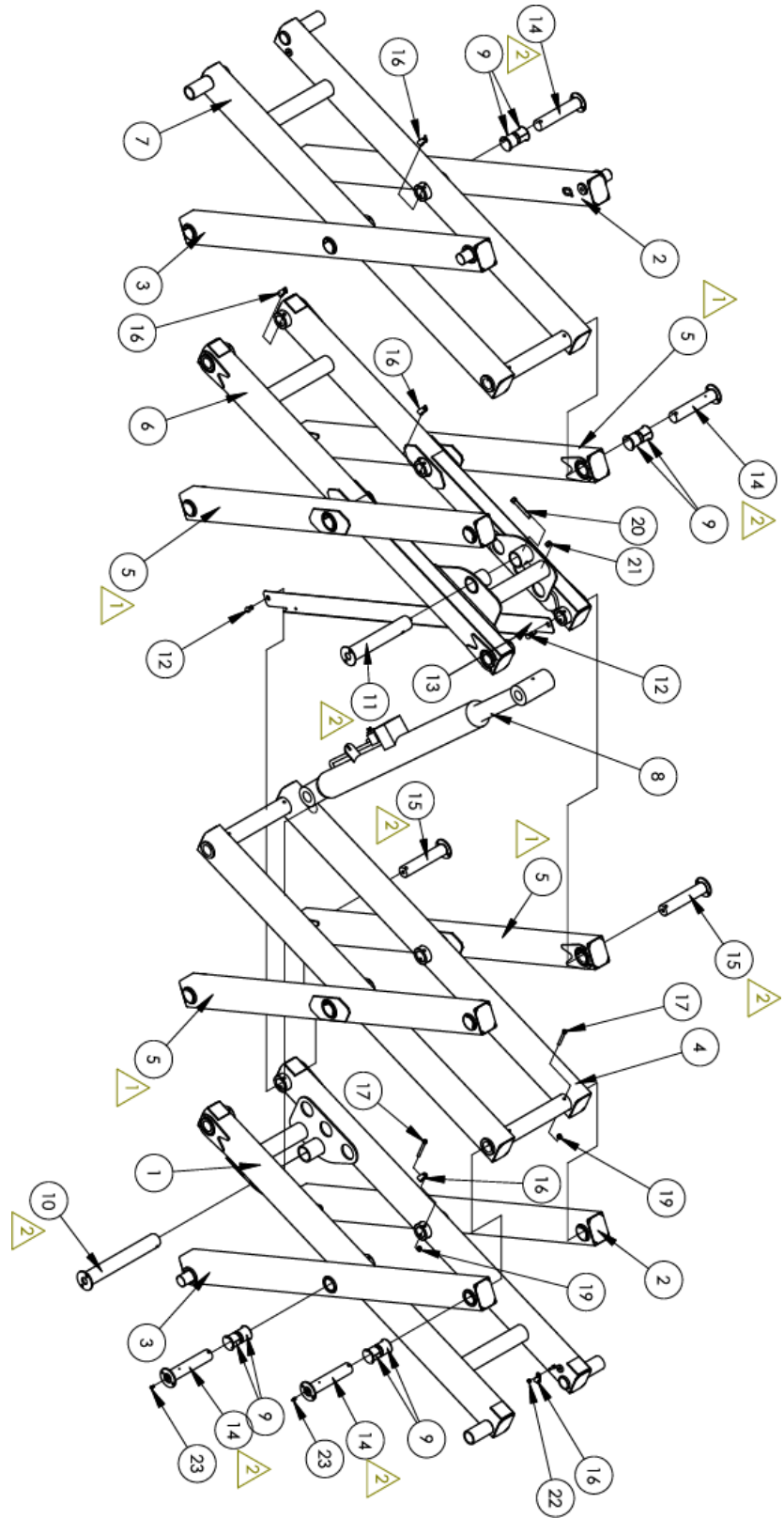

Platform Assembly

503501-000

Item	Part	Description	QTY.
1	066250-001	PLATFORM WELDMENT	1
2	066251-001	EXTENSION DECK WELDMENT	1
3	502204-000	GATE SPRING	1
4	503643-000	SIDE RAIL WELDMENT	2
5	503646-000	END RAIL WELDMENT	1
6	502145-000	LEVER PIVOT BRACKET WELDMENT	1
7	503650-000	GATE WELDMENT	1
8	502206-000	DOOR PIVOT INSERT	1
9	503658-000	DECK BRACKET (LH)	1
10	502291-000	HARNES HARDPOINT	1
11	502132-001	ROLLER, EXTENSION DECK	4
12	503640-000	GUARDRAIL WELDMENT	1
13	101188-010	UCB (PLASTIC ENCLOSURE)	1
14	502150-000	ROLLER MOUNT WELDMENT	2
15	502141-000	LEVER BRACKET	1
16	502131-000	EXTENSION DECK GUIDE	2
17	502148-000	WEAR PAD, EXTENSION DECK	2
18	502129-000	ROLLER STOP	2
19	502128-000	WEAR PAD	2
20	500311-000	FOAM TUBING	1
21	503648-000	GATE LATCH WELDMENT	2
22	058251-000	LOCKING LATCH, LADDER	1
23	503765-000	U - BOLT	1
24	503767-000	LATCH ACTUATOR	1
25	056059-030	HEX HEAD BOLT (M8 X 30)	2
26	502235-000	HOUSING, U - BOLT	1
27	056059-055	HEX HEAD BOLT (M8 X 55)	1
28	503658-001	GATE STOP BRACKET (RH)	1
29	010076-000	DOCUMENT BOX	1
30	502164-000	BRACKET, UCB BOTTOM	1
31	502231-000	PIPE CLAMP, GATE HINGE	1
32	503657-000	BRACKET	2
33	058492-020	HEX HEAD SCREW (M8 X 20)	2
34	056066-010	NYLOCK NUT (M10)	5
35	056069-008	WASHER (M8)	5
36	009442-003	PLUNGER ASSY	3
37	056060-050	HEX HEAD BOLT (M10 X 50)	4
38	056021-010	SPRING WASHER (M10)	9
39	058493-025	HEX HEAD SCREW (M10 X 25)	1
40	056066-008	NYLOCK NUT (M8)	3
41	503805-000	HEX HEAD BOLT (3/8" - 16 UNC - 28 X 1")	5
42	056059-050	HEX HEAD BOLT (M8 X 50)	1
43	058491-016	HEX HEAD BOLT (M6 X 16)	4
44	056069-006	WASHER (M6)	5
45	056066-006	NYLOCK NUT (M6)	5
46	056060-060	HEX HEAD BOLT (M10 X 60)	2
47	501253-025	BUTTON HEAD SCREW (M6 X 25)	1

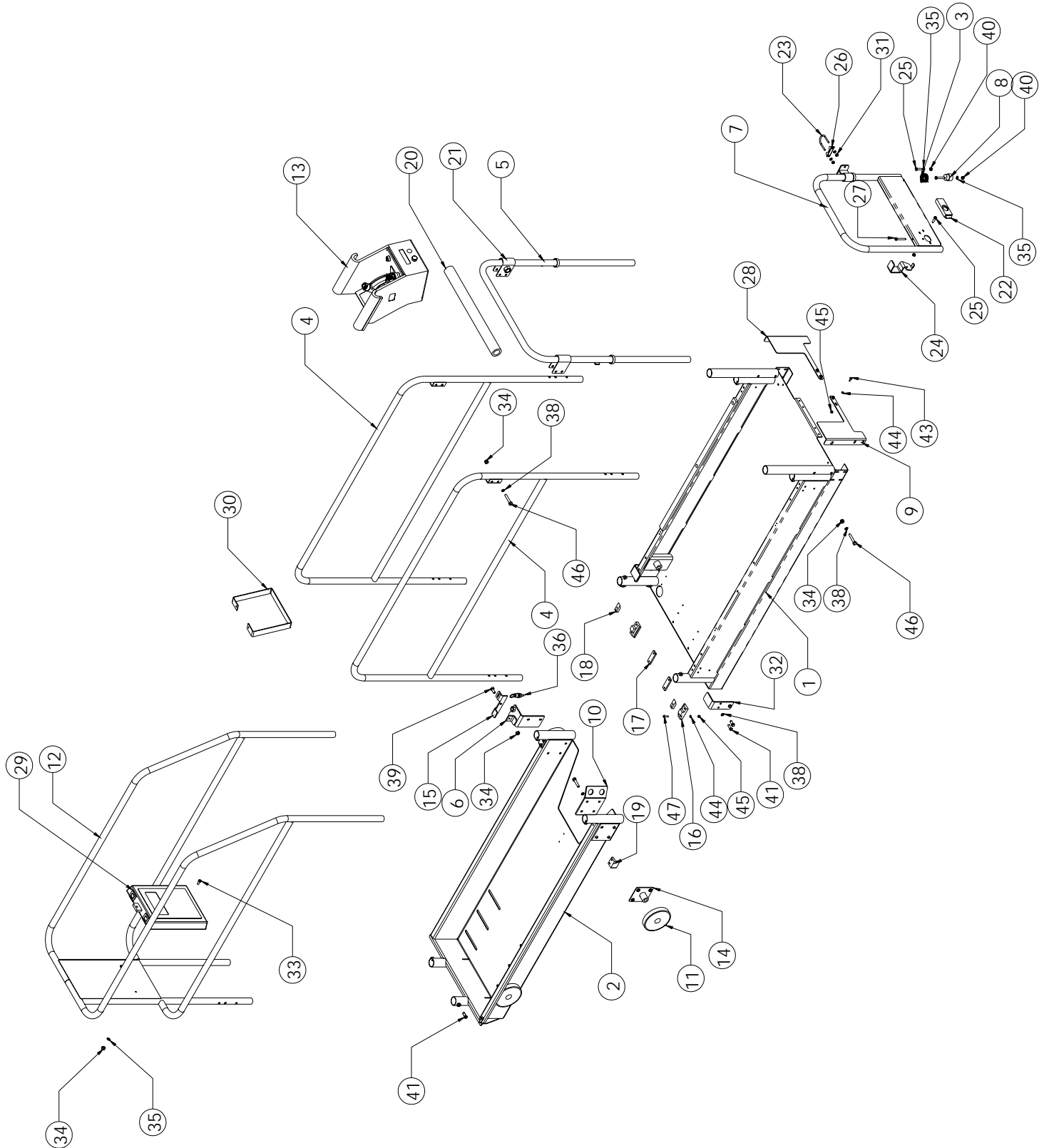

Rear Wheel Assembly

Item	Part	Description	QTY.
1			
2	504157-000	BEARING	1
3	504351-000	WHEEL	1
4	503677-000	PLAIN WASHER	1
5	503755-000	CASTLE NUT	1
6			
7	502152-000	SPLIT PIN	1

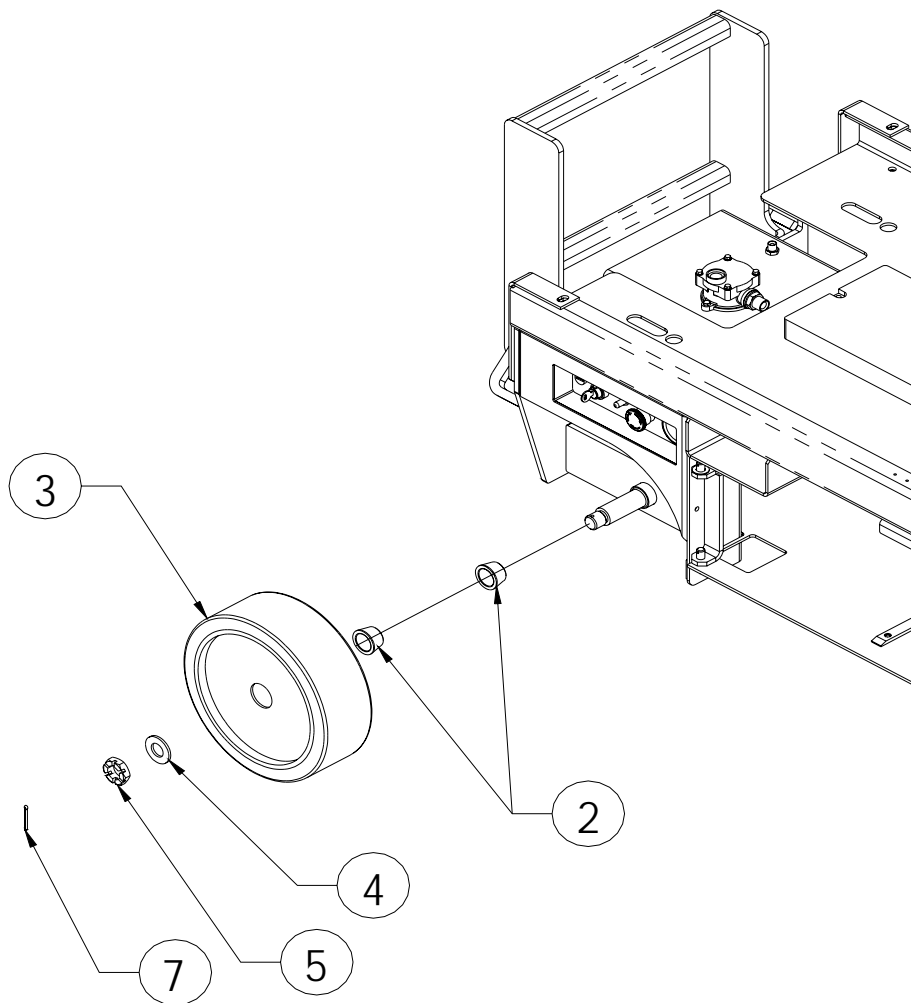

Control Valve Assembly

503800-001

Item	Part	Description	QTY.
1		TEST PORT	1
2	058358-000	FITTING, 1/4" - 1/4" MALE/MALE	1
3	058358-000	FITTING, 1/4" - 1/4" MALE/MALE	1
4	058358-000	FITTING, 1/4" - 1/4" MALE/MALE	1
5	057122-000	FITTING, 3/8" - 3/8" MALE/MALE	1
6	057122-000	FITTING, 3/8" - 3/8" MALE/MALE	1
7	503806-000	FITTING, 1/4" - 1/4" MALE/MALE BULKHEAD	1
8	057122-000	FITTING, 3/8" - 3/8" MALE/MALE	1
9	057358-000	FITTING, 1/4" - 1/4" MALE/MALE	1
10	N/A	N/A	-
11	057377-000	FITTING, 1/2" - 1/2" (MALE/MALE)	1
12	503802-000	CHECK VALVE, POTHOLE	1
13	503803-000	CROSS LINE RELIEF VALVE (DRIVE)	1
14	503804-000	VALVE, SOLENOID (DRIVE)	1
15	503805-000	VALVE, SOLENOID (DRIVE/LIFT)	1
16	503803-000	CROSS LINE RELIEF VALVE (DRIVE)	1
17	503807-000	PRESSURE RELIEF (MAIN LIFT)	1
18	503808-000	VALVE, SOLENOID (STEERING)	1
19	503809-000	FLOW RESTRICTOR (STEERING)	1
20	058728-000	RELIEF VALVE (STEERING)	1
21	057122-000	FITTING, 3/8" - 3/8" MALE/MALE	1
22	503810-000	RELIEF VALVE (MAIN RELIEF)	1
23	500303-000	COIL 18V	6

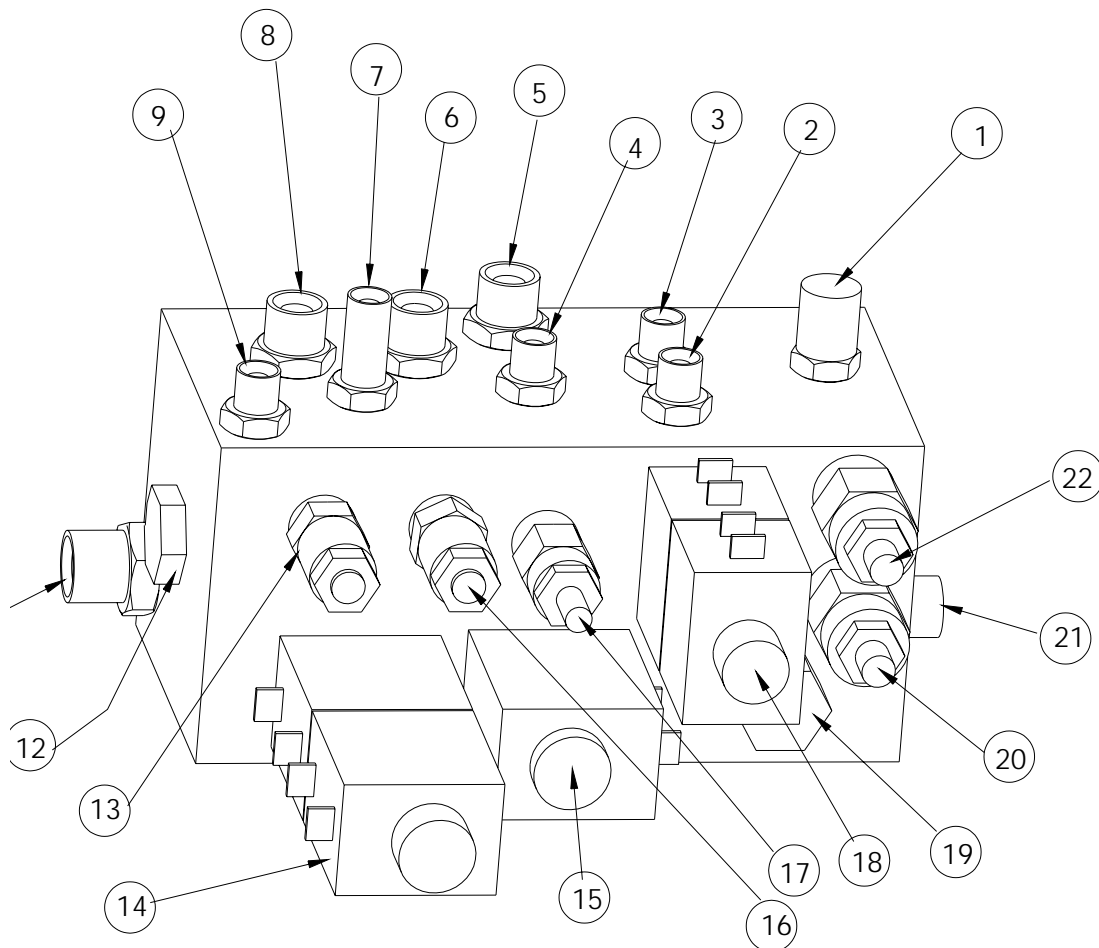

Lower Controls Assembly

Item	Part	Description	QTY.
1	503609-001	WHEEL COVER PLATE	1
2	503611-000	CONTROL BOX	1
3	503612-000	CONTROL PANEL	1
4	502544-000	KEY	1
5	502589-000	KEY SWITCH & MOUNT	1
6	502520-000	ENABLE BUTTON	1
7	502251-000	TOGGLE SWITCH	1
8	501867-000	EMERGENCY STOP BUTTON	1

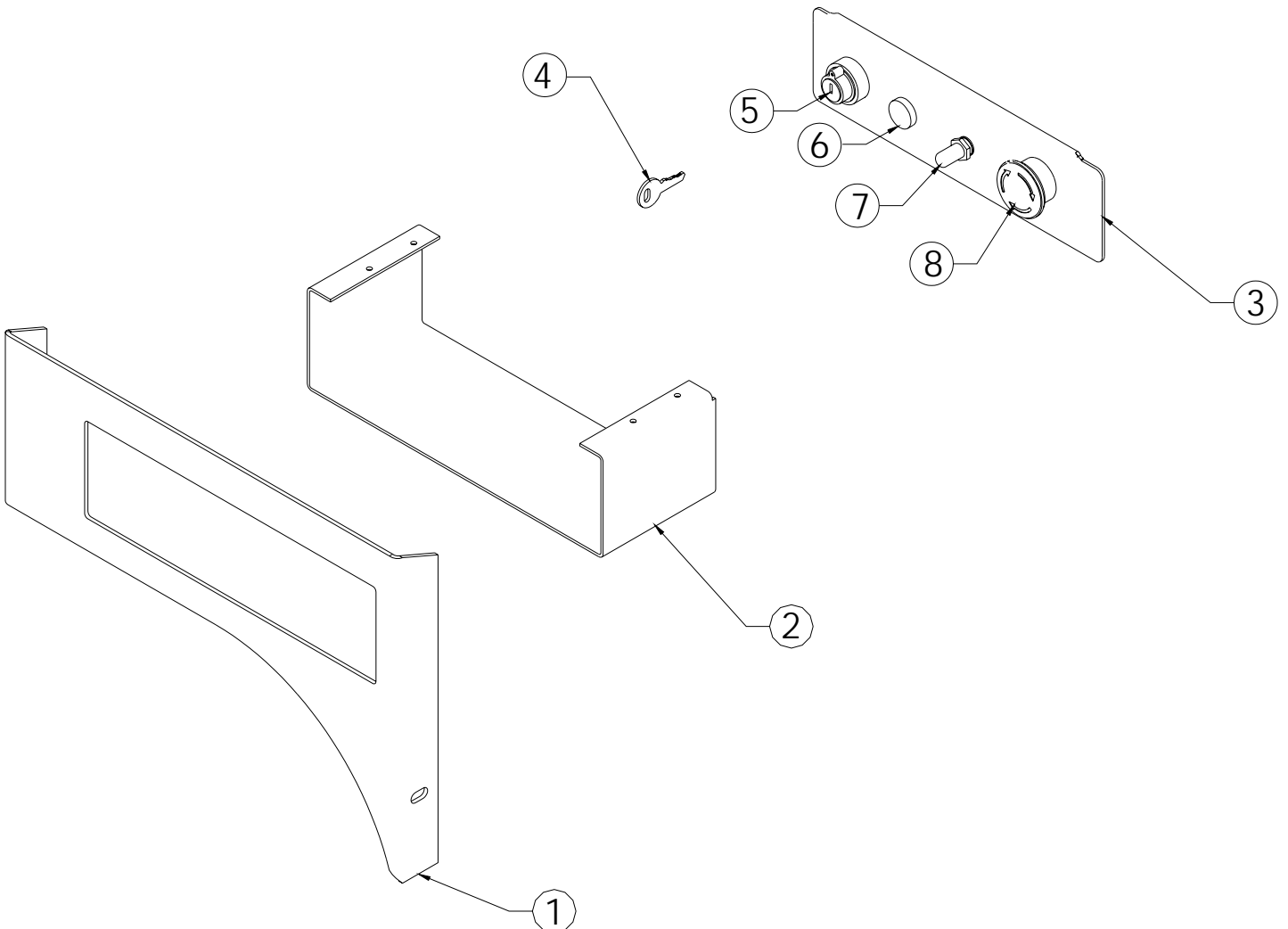
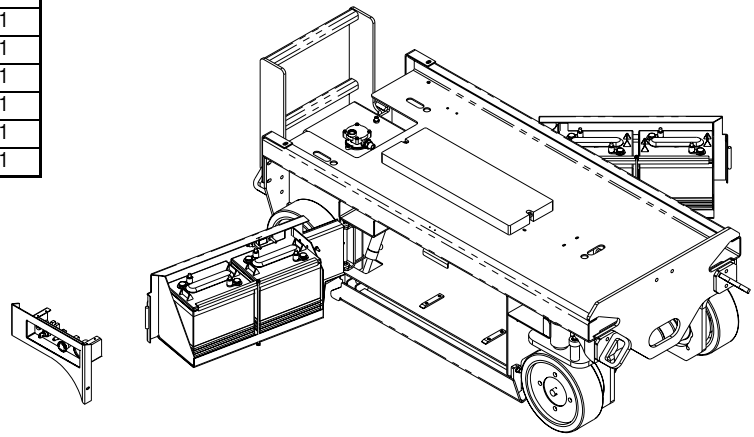

Hydraulic Tank Assembly

503696-000

Item	Part	Description	QTY.
1	101056-001	HYDRAULIC TANK (TANK ONLY)	1
2	068982-001	FILER CAP	1
3	503787-000	DRAIN LINE RETURN (1/4" NPT - 1/4" BSP M/M)	1
4	503786-000	RETURN LINE ADAPTOR (1/2" NPT - 1/2" BSP M/M)	1
5	503788-000	SUCTION ADAPTOR (3/4" NPT - 3/4" BSP M/M)	1
6	502196-000	SUCTION STRAINER (INSIDE TANK)	1

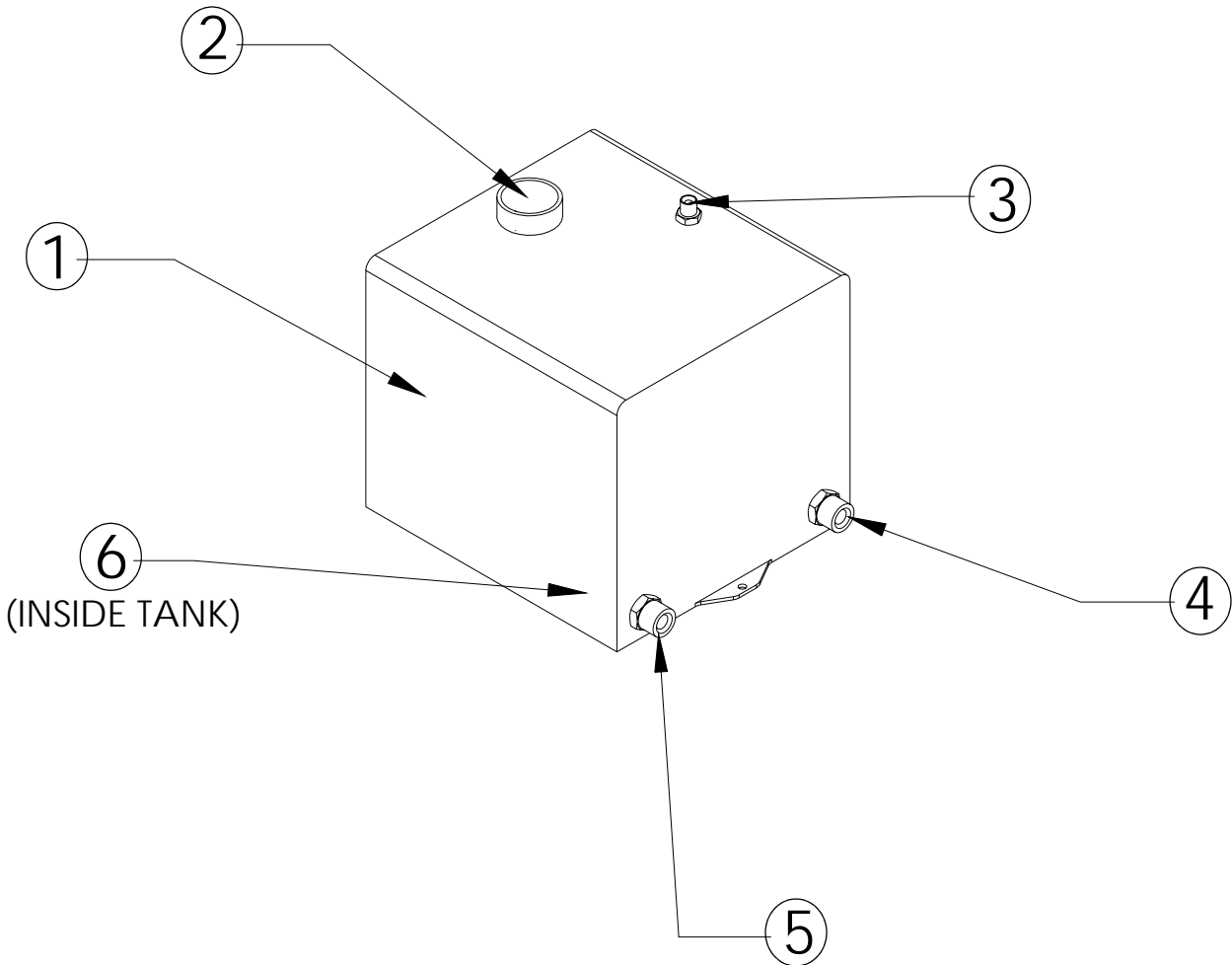

Upper Controls Assembly

Item	Part	Description	QTY.
1	501867-000	EMERGENCY STOP BUTTON	1
2	501882-002	RUBBER BOOT, STEERING	1
3	501882-000	JOYSTICK	1
4	501882-001	RUBBER BOOT, JOYSTICK	1
5	502486-000	DECAL	1
6	501592-000	MOUNTING PLATE	1

Item	Part	Description	QTY.
7	502591-000	SEAL	1
8	502453-000	CIRCUIT BOARD	1
9	502587-001	SOCKET, MAIN HARNESS	1
10	502605-000	SOCKET, OVERLOAD	1
11	502496-000	UCB, BOX ONLY	1

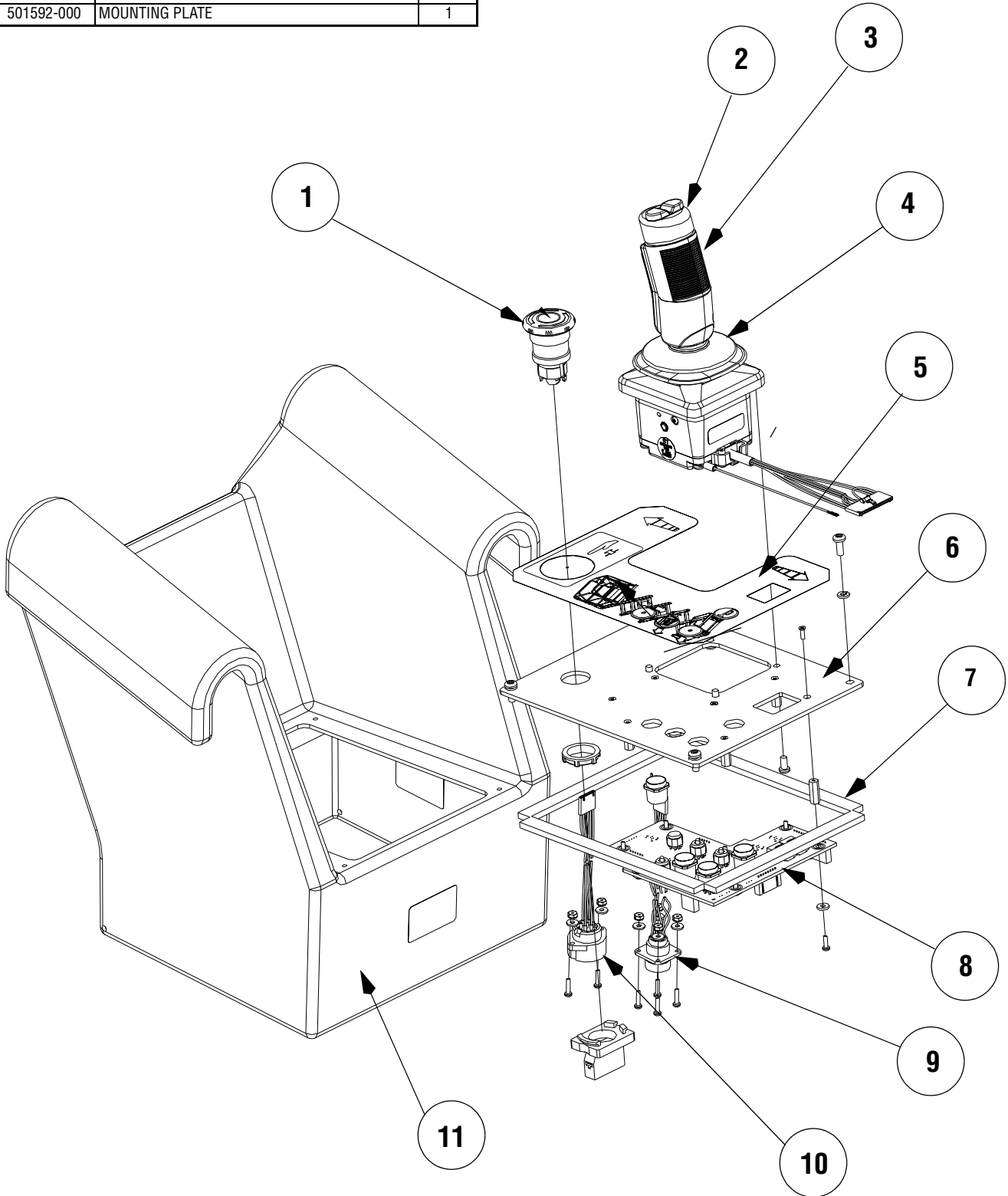

Hydraulic Assembly

503507-000

Item	Part	Description	QTY.
1	503800-001	HYDRAULIC MANIFOLD	1
2	503687-000	HYDRAULIC CYLINDER (STEERING)	1
3	503678-000	DRIVE MOTOR	2
4	504536-000	PUMP MOTOR	1
5	503696-000	HYDRAULIC TANK	1
6	503795-000	HYDRAULIC CYLINDER (MAIN LIFT)	1
7	503622-001	HYDRAULIC CYLINDER (POTHOLE)	1
8	503622-000	HYDRAULIC CYLINDER (POTHOLE)	1
9	503693-000	HOSE, MANIFOLD TO STEERING CYLINDER	2
10	503777-000	HOSE, DRIVE MOTOR TO DRIVE MOTOR	1
11	503776-000	HOSE, MANIFOLD TO DRIVE MOTOR	1
12	503775-000	HOSE, MANIFOLD TO DRIVE MOTOR	1
13	503779-000	HOSE, PUMP TO MANIFOLD	1
14	~	MANIFOLD TO FILTER (RETURN)	~

~	058170-000	1/2" BSP Female / Female Swept 90	1
~	503785-000	1/2" BSP Male / Female Swept 90	1
15	503781-000	HOSE, FILTER TO TANK (RETURN)	1
16	503778-000	HOSE, TANK TO PUMP (SUCTION)	1
17	503699-000	HOSE, MAIN LIFT CYLINDER TO TANK (DRAIN)	1
18	503698-000	HOSE, MANIFOLD TO LIFT CYLINDER	1
19	N/A	N/A	-
20	N/A	N/A	-
21	503694-000	HOSE, MANIFOLD TO POTHOLE TEE	1
22	503695-000	HOSE, POTHOLE TEE TO MANIFOLD	1
23	503696-000	HOSE, POTHOLE TEE TO POTHOLE CYLINDER	4
24	503691-000	HOSE, MANIFOLD TO BRAKE TEE	1
25	503692-000	HOSE, BRAKE TEE TO DRIVE MOTORS LH & RH	2
26	057107-000	FILTER	1
*	005154-002	FILTER ELEMENT	1

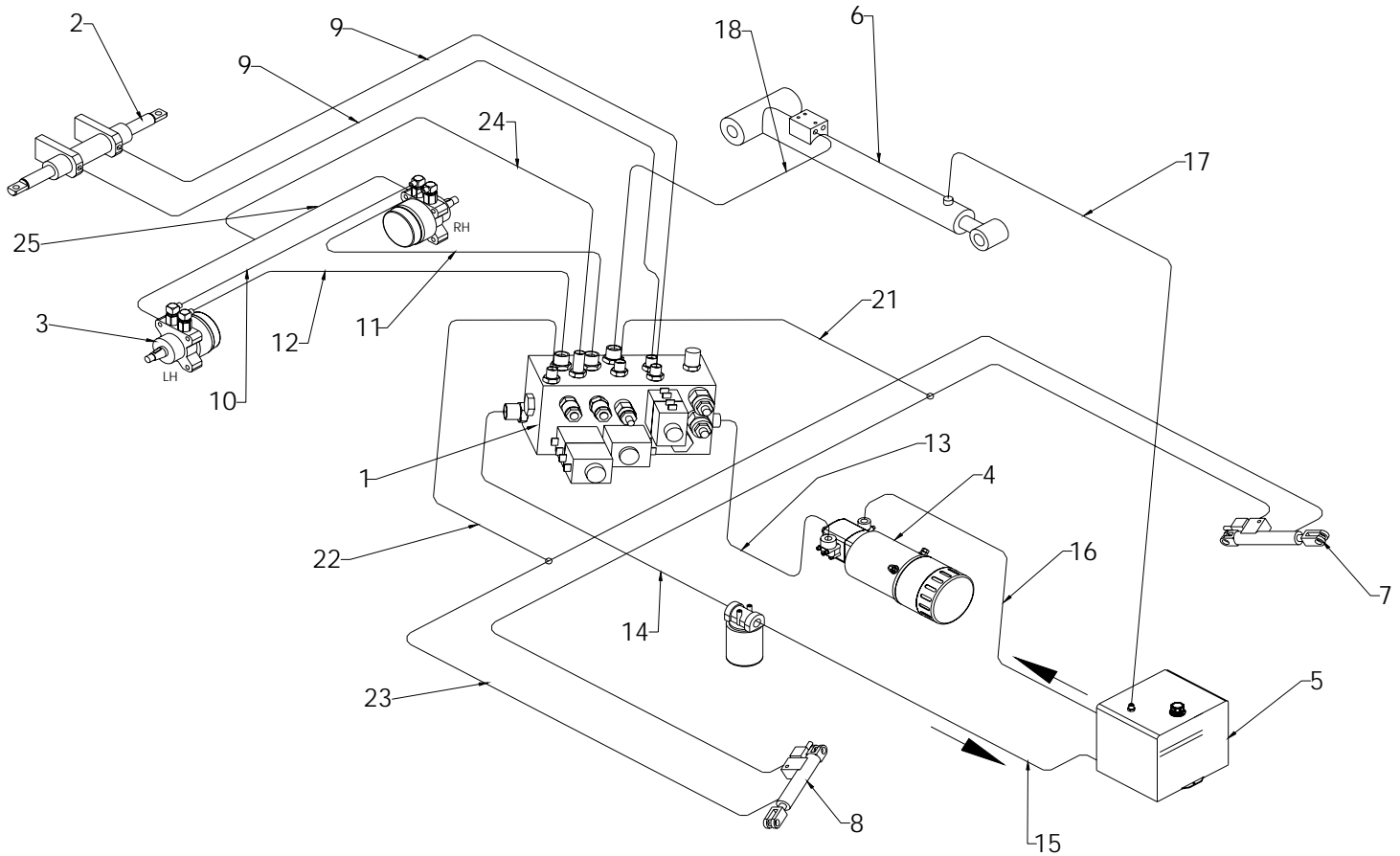

Hydraulic Schematic

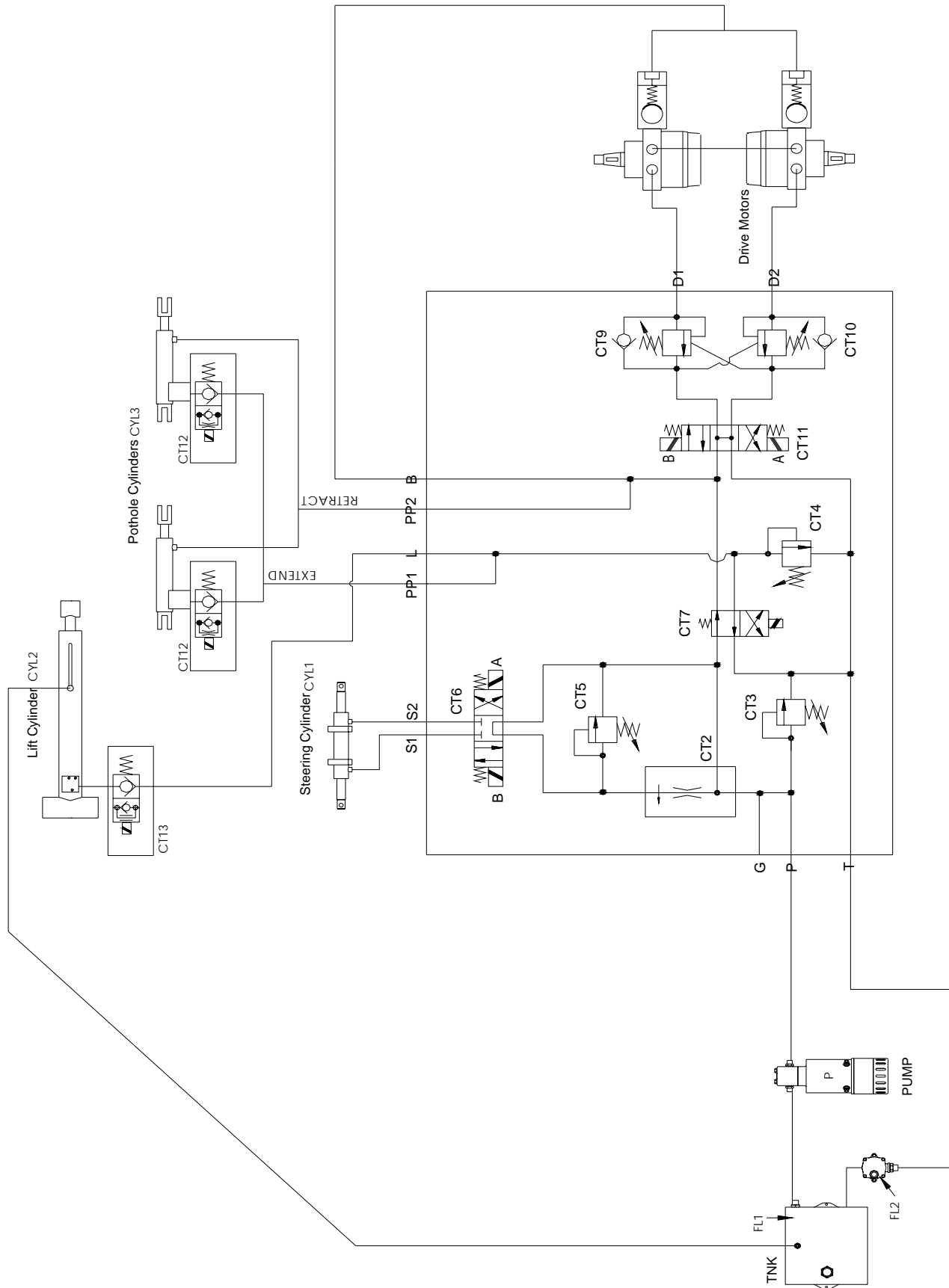

Hydraulic Cylinder Assembly (Lift)

503795-000

Item	Part	Description	QTY.
1	503795-010	SEAL KIT	1
2	500079-000	FLANGED BUSHING	4
3	503789-000	EMERGENCY DOWN CABLE ASSY	1
4	057048-000	GREASE NIPPLE (M6)	2
5	503820-000	VALVE, EMERGENCY DOWN	1

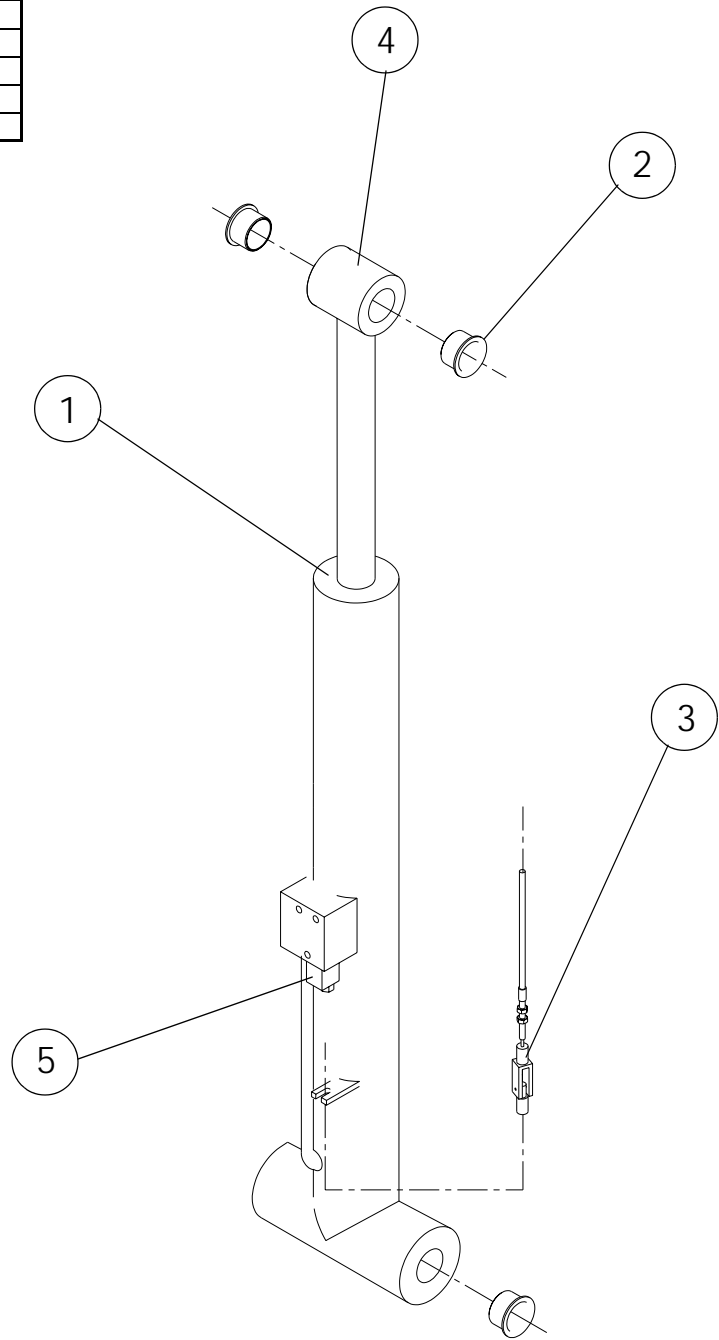

Hydraulic Cylinder Assembly (Steer)

503687-000

Item	Part	Description	QTY.
1	503687-010	SEAL KIT	1
2	501439-000	BUSHING, PLAIN	2
3	501340-000	BUSHING, FLANGED	2

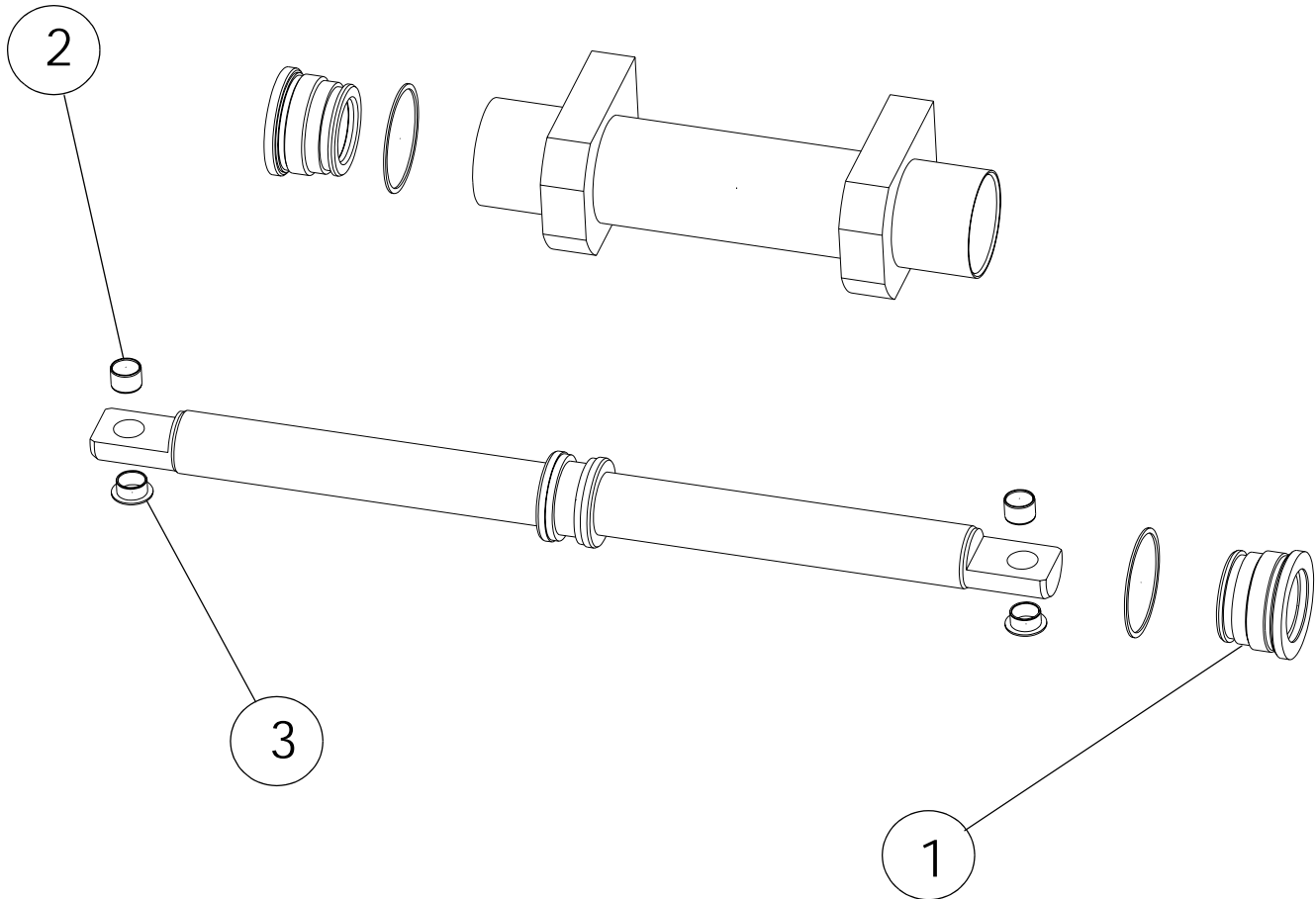

Hydraulic Cylinder Assembly (Pothole)

503622-000

Item	Part	Description	QTY.
1	503622-010	SEAL KIT	1
2	503784-000	FITTING (1/8" - 1/8" M/M)	2
3	503783-000	BONDED SEAL (1/8")	2

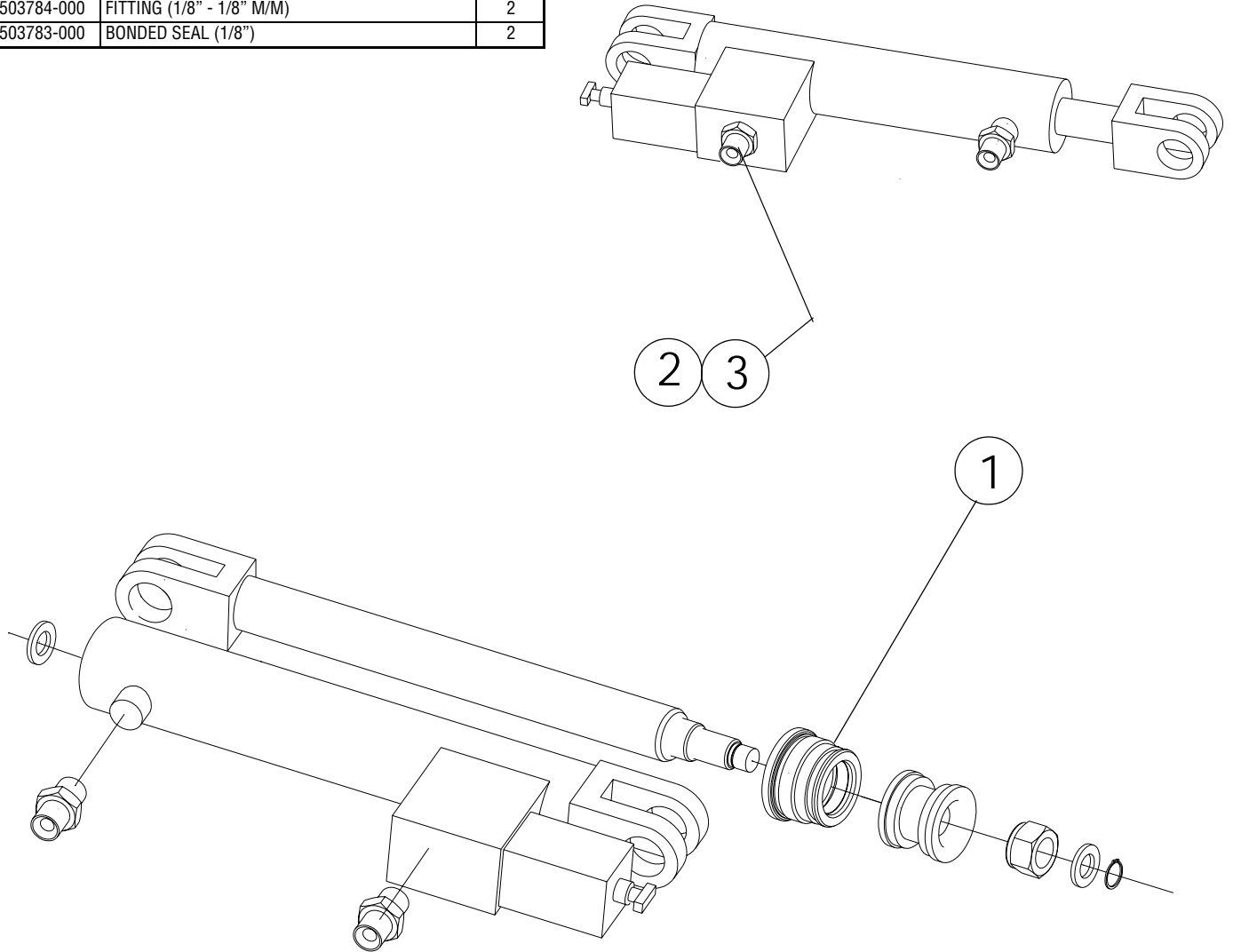

Electrical Assembly

503700-000

Item	Part	Description	QTY.
1	502483-000	ECU	1
2	502593-000	J1 HARNESS	1
3	503800-001	MAIN MANIFOLD BLOCK	1
4	505005-000	UPPER CONTROLS	1
5	505006-000	LOWER CONTROLS	1
6	058912-000	TILT SENSOR	1
7	501868-000	HORN	1
8	502588-000	ALARM	1
9	505072-000	PROXIMITY SENSOR	1
10	502494-000	FUSE	1
11	058937-000	BATTERY DISCONNECT PLUG	1
12	502594-000	HARNESS, BATTERY DISCONNECT - BATT (-)	1
13	502595-000	HARNESS, BATTERY DISCONNECT - BATT (+)	1
14	501074-000	BATTERY	4

Item	Part	Description	QTY.
15	502596-000	HARNESS, BATTERY INTERCONNECT	3
16	503097-000	CHARGER	1
17	058783-000	CHARGER DISCONNECT PLUG	1
18	502597-000	HARNESS, CHARGER DISCONNECT (+) - LINE CON4	1
19	502598-000	HARNESS, CHARGER DISCONNECT (-) - BATT (-)	1
20	502599-000	HARNESS, CHARGER DISCONNECT (-) - LINE CON2	1
21	502600-000	LINE CONTACTOR 3 - FUSE	1
22	502601-000	LINE CONTACTOR 5 - LINE CONTACTOR 3	1
23	502489-000	LINE CONTACTOR	1
24	502602-000	LINE CONTACTOR 2 - MOTOR CONT B-	1
25	502603-000	LINE CONTACTOR 1 - MOTOR CONT ENABLE	1
26	502604-000	LINE CONTACTOR 6 - PUMP MOTOR	1
27	502492-000	MOTOR CONTROLLER	1
28	504536-000	PUMP MOTOR (Serial numbers 50691 to current)	1

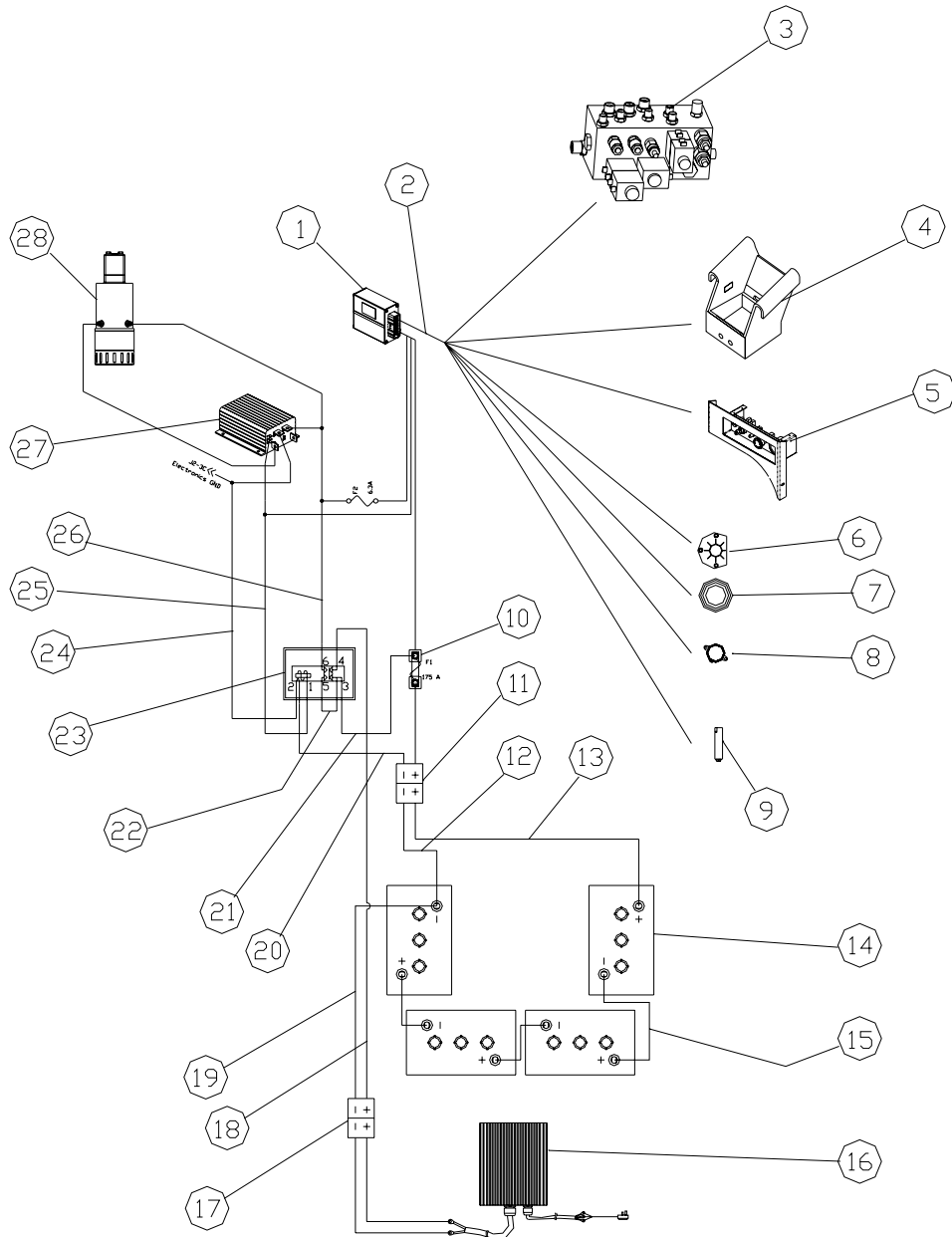

Overload Assembly

504557-000

Item	Part	Description	QTY.
1	503950-000	MOUNTING PLATE, ELECTRICAL BOX	1
2	504566-000	MOUNTING PLATE, CIRCUIT BOARD	1
3	504558-000	CIRCUIT BOARD	1
4	504559-000	ANGLE TRANSDUCER	1
5	504560-000	PRESSURE TRANSDUCER	1

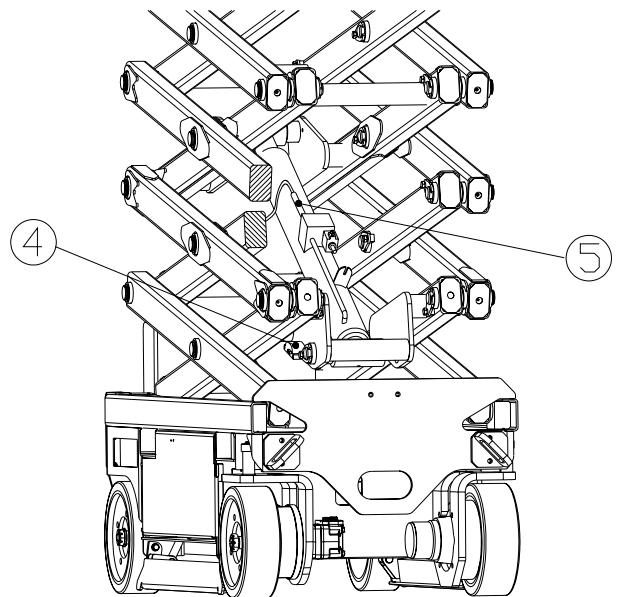
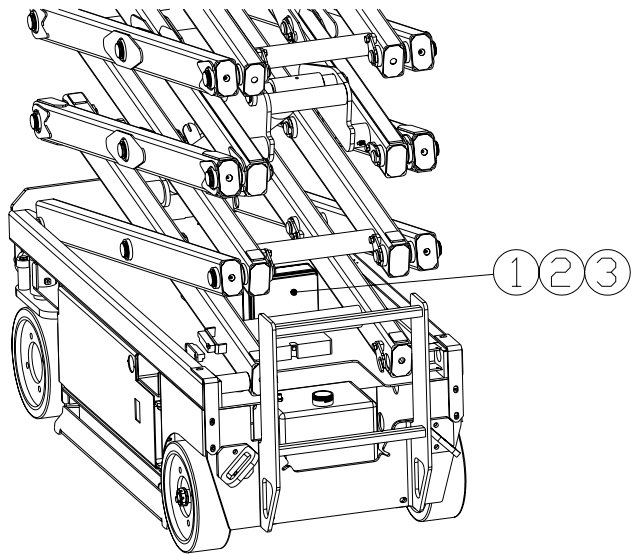

Label Kit, European (English)

503720-000

Item	Part	Description	QTY.
1	067195-001	DECAL, HAZZARDS	1
2	100102-900	DECAL, NOT INSULATED	1
3	503721-000	DECAL, LOWER CONTROLS	1
4	066551-950	DECAL, MAX LOAD (EXT DECK)	1
5	101210-000	DECAL, HYDROGEN GAS	2
6	501453-000	DECAL, CRUSHING (FOOT)	4
7	503723-000	DECAL, BATTERY DISCONNECT	1
8	066556-900	DECAL, DANGER	1
9	066557-951	DECAL, SAFE WORKING LOAD	2
10	502480-000	DECAL, EMERGENCY DOWN	1
11	502486-000	DECAL, UPPER CONTROLS	1
12	066522-900	DECAL, BATTERY	1
13	014222-903	DECAL, FORKLIFT POINT	4
14	503724-000	DECAL, CRUSHING (HAND)	2
15	063255-901	DECAL, SCISSOR BRACE	1
16	010076-901	DECAL, DOCUMENTS ENCLOSED	1
17	068635-001	DECAL, SAFETY HARNESS POINT	1
18	503725-000	DECAL, NAMEPLATE	1
19	062562-951	DECAL, BATTERIES ARE BALLAST	2
20	107053-000	DECAL, HORN	1
21	503722-000	DECAL, "MX19" LIVERY	2
22	057696-000	DECAL, "UpRight"	2
23	058881-000	HAZZARD TAPE	
24	502258-000	SAFETY WALK (6")	4.2M
25	502259-000	SAFETY WALK (12")	0.6M

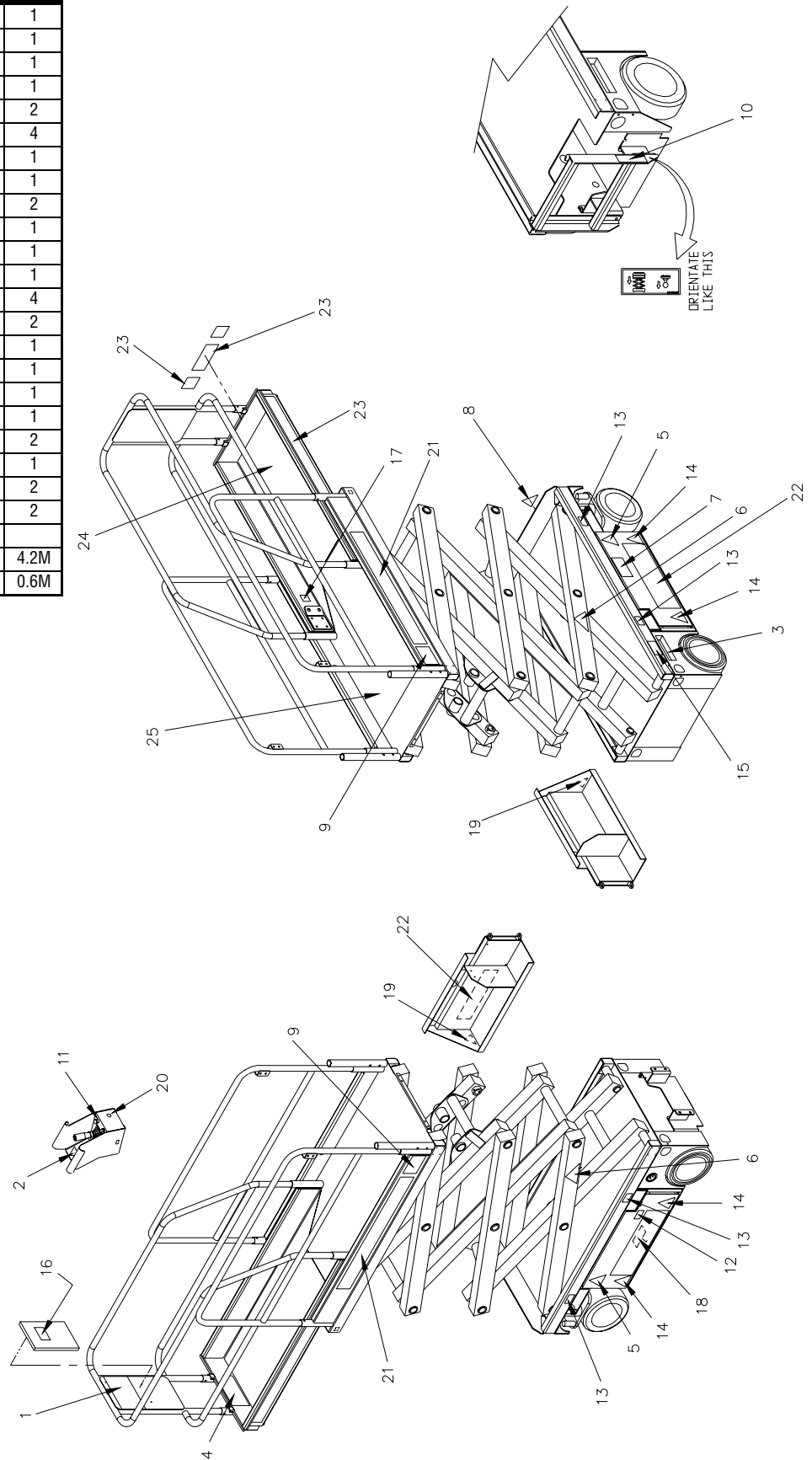

Label Kit, German

503720-201

Item	Part	Description	QTY.
1	067195-201	DECAL, HAZZARDS	1
2	100102-900	DECAL, NOT INSULATED	1
3	503721-000	DECAL, LOWER CONTROLS	1
4	066551-950	DECAL, MAX LOAD (EXT DECK)	1
5	101210-000	DECAL, HYDROGEN GAS	2
6	501453-000	DECAL, CRUSHING (HAND)	2
7	503723-000	DECAL, BATTERY DISCONNECT	1
8	066556-900	DECAL, DANGER	1
9	066557-951	DECAL, SAFE WORKING LOAD	2
10	005223-906	DECAL, EMERGENCY DOWN	1
11	502486-000	DECAL, UPPER CONTROLS	1
12	066522-900	DECAL, BATTERY	1
13	014222-903	DECAL, FORKLIFT POINT	4
14	101208-001	DECAL, CRUSHING	4
15	063255-901	DECAL, SCISSOR BRACE	1
16	010076-901	DECAL, DOCUMENTS ENCLOSED	1
17	068635-001	DECAL, SAFETY HARNESS POINT	1
18	503725-000	DECAL, NAMEPLATE	1
19	062562-951	DECAL, BATTERIES ARE BALLAST	2
20	107053-000	DECAL, HORN	1
21	503722-000	DECAL, "MX19" LIVERY	2
22	057696-000	DECAL, "UpRight"	2
23	058881-000	HAZZARD TAPE	
24	502258-000	SAFETY WALK (6")	4.2M
25	502259-000	SAFETY WALK (12")	0.6M

Label Kit, French

503720-301-

Item	Part	Description	QTY.
1	067195-301	DECAL, HAZZARDS	1
2	100102-900	DECAL, NOT INSULATED	1
3	503721-000	DECAL, LOWER CONTROLS	1
4	066551-950	DECAL, MAX LOAD (EXT DECK)	1
5	101210-000	DECAL, HYDROGEN GAS	2
6	501453-000	DECAL, CRUSHING (HAND)	2
7	503723-000	DECAL, BATTERY DISCONNECT	1
8	066556-900	DECAL, DANGER	1
9	066557-951	DECAL, SAFE WORKING LOAD	2
10	005223-906	DECAL, EMERGENCY DOWN	1
11	502486-000	DECAL, UPPER CONTROLS	1
12	066522-900	DECAL, BATTERY	1
13	014222-903	DECAL, FORKLIFT POINT	4
14	101208-001	DECAL, CRUSHING	4
15	063255-901	DECAL, SCISSOR BRACE	1
16	010076-901	DECAL, DOCUMENTS ENCLOSED	1
17	068635-001	DECAL, SAFETY HARNESS POINT	1
18	503725-000	DECAL, NAMEPLATE	1
19	062562-951	DECAL, BATTERIES ARE BALLAST	2
20	107053-000	DECAL, HORN	1
21	503722-000	DECAL, "MX19" LIVERY	2
22	057696-000	DECAL, "UpRight"	2
23	058881-000	HAZZARD TAPE	
24	502258-000	SAFETY WALK (6")	4.2M
25	502259-000	SAFETY WALK (12")	0.6M

Label Kit, USA

065712-033

Item	Part	Description	QTY.
1	503722-000	LABEL UPRIGHT	2
2	~	~	~
3	061683-014	LABEL UPRIGHT	2
4	067195-001	LABEL INSTRUCTIONS	1
5	100102-900	LABEL NOT INSULATED	1
6	010076-000	MANUAL CASE	1
7	~	~	~
8	011248-004	LOCKNUT 1/4-20UNC HEX	4
9	011252-006	SCREW 1/4-20UNC HHC X 3/4	4
10	011240-004	WASHER 1/4 STD FLAT	4
11	066559-900	LABEL CONTROLS	1
12	066551-950	LABEL MAX LOAD DECK EXT	1
13	101210-000	LABEL WARNING BATTERIES	2
14	101208-000	LABEL WARNING PINCH POINT	2
15	~	~	~
16	107051-900	LABEL BATTERY DISCONNECT	1
17	066556-900	LABEL CAUTION	1
18	066557-951	LABEL MAX LOAD PLATFORM	2
19	005223-906	LABEL EMERGENCY LOWERING	1
20	101222-904	LABEL CONTROLLER	1
21	064936-099	TAPE REFLECTIVE	7.08ft
22	066522-900	LABEL BATTERY CHARGER	1
23	014222-903	LABEL FORK-LIFT HERE	5
24	101208-001	LABEL WARNING	4
25	063255-901	LABEL SCISSORS BRACE	1
26	010076-901	LABEL INST.	1
27	~	~	~
28	068635-001	LABEL HARNESS HARDPOINT	1
29	061205-003	NAME PLATE	1
30	065368-000	TACK	4
31	064444-000	LABEL USA	4
32	060830-003	SAFETY WALK 6 X 21	1
33	060830-002	SAFETY WALK 8 X 36	3
34	060830-001	SAFETY WALK 4 X 20	3
35	062562-951	LABEL DANGER	2
36	107053-000	LABEL HORN	1
~	~	~	~
39	067195-201	LABEL INSTRUCTION	1

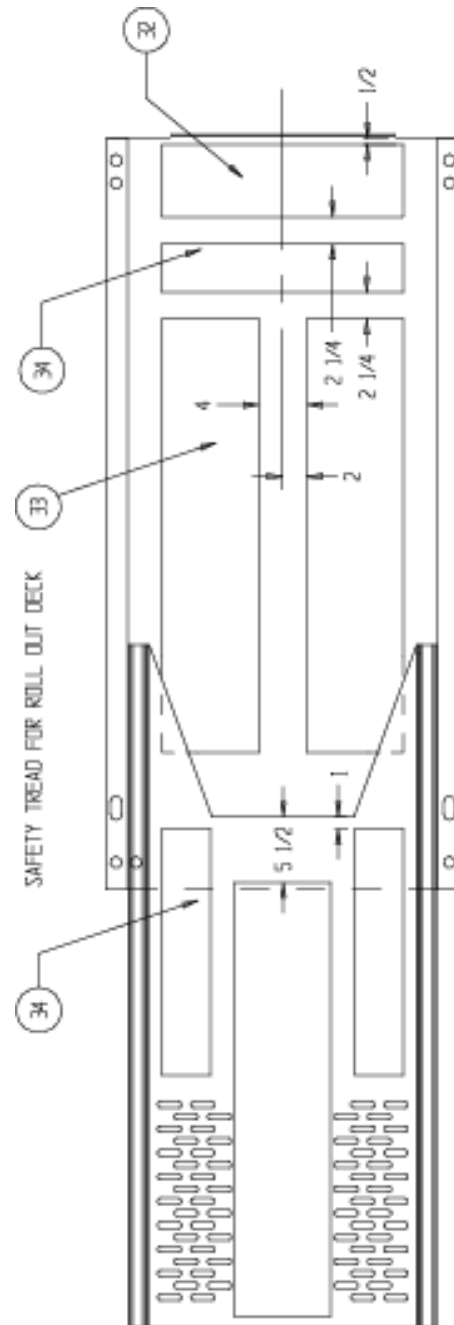

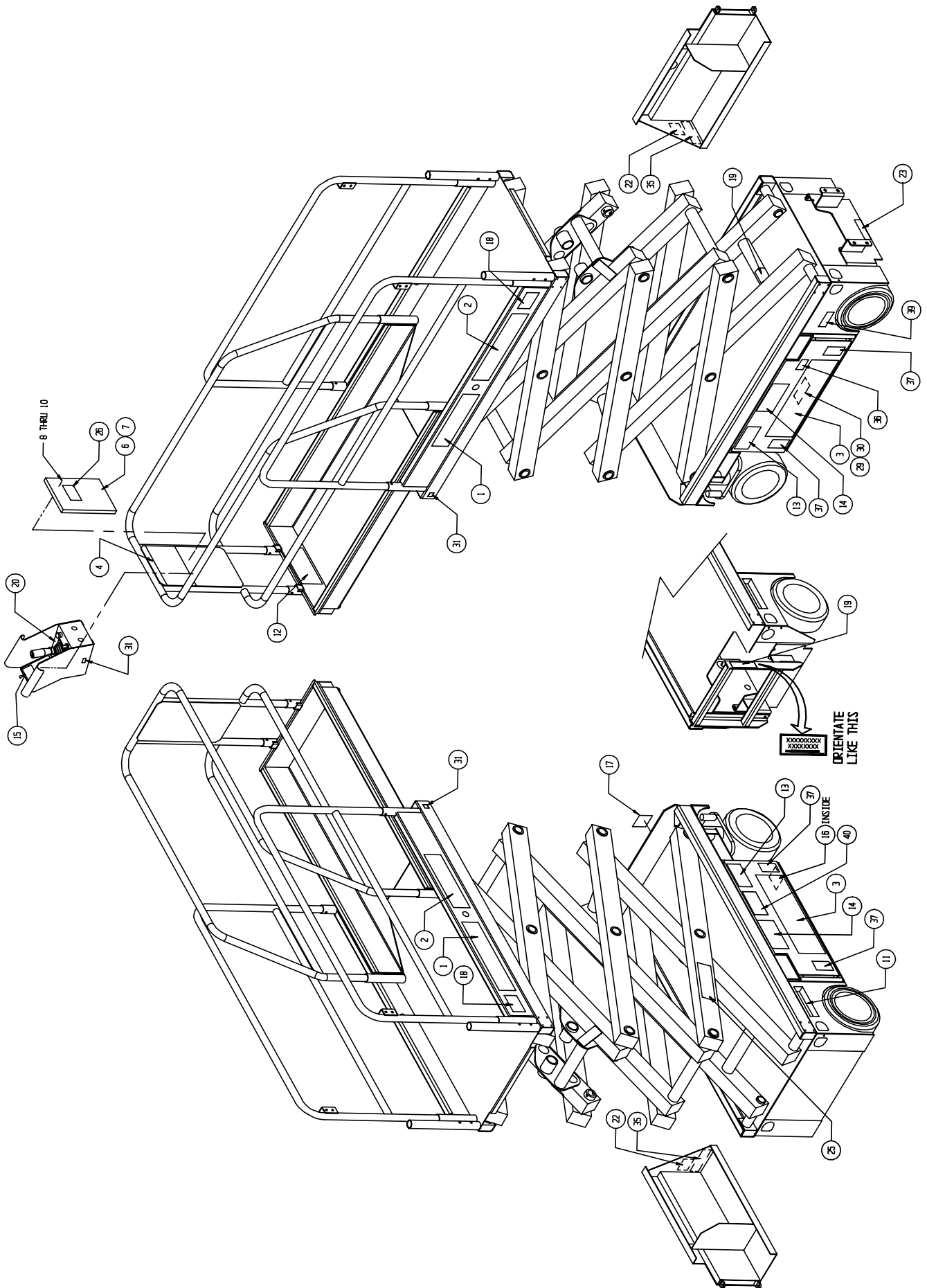

Local Distributor:

Lokaler Vertiebshändler:

Distributeur local:

El Distribuidor local:

Il Distributore locale:

USA

TEL: +1 (559) 443 6600
FAX: +1 (559) 268 2433

UpRight
POWERED ACCESS

www.upright.com

Europe

TEL: +44 (0) 845 1550 058
FAX: +44 (0) 195 2299 948

PN - 503727-002