

UpRight

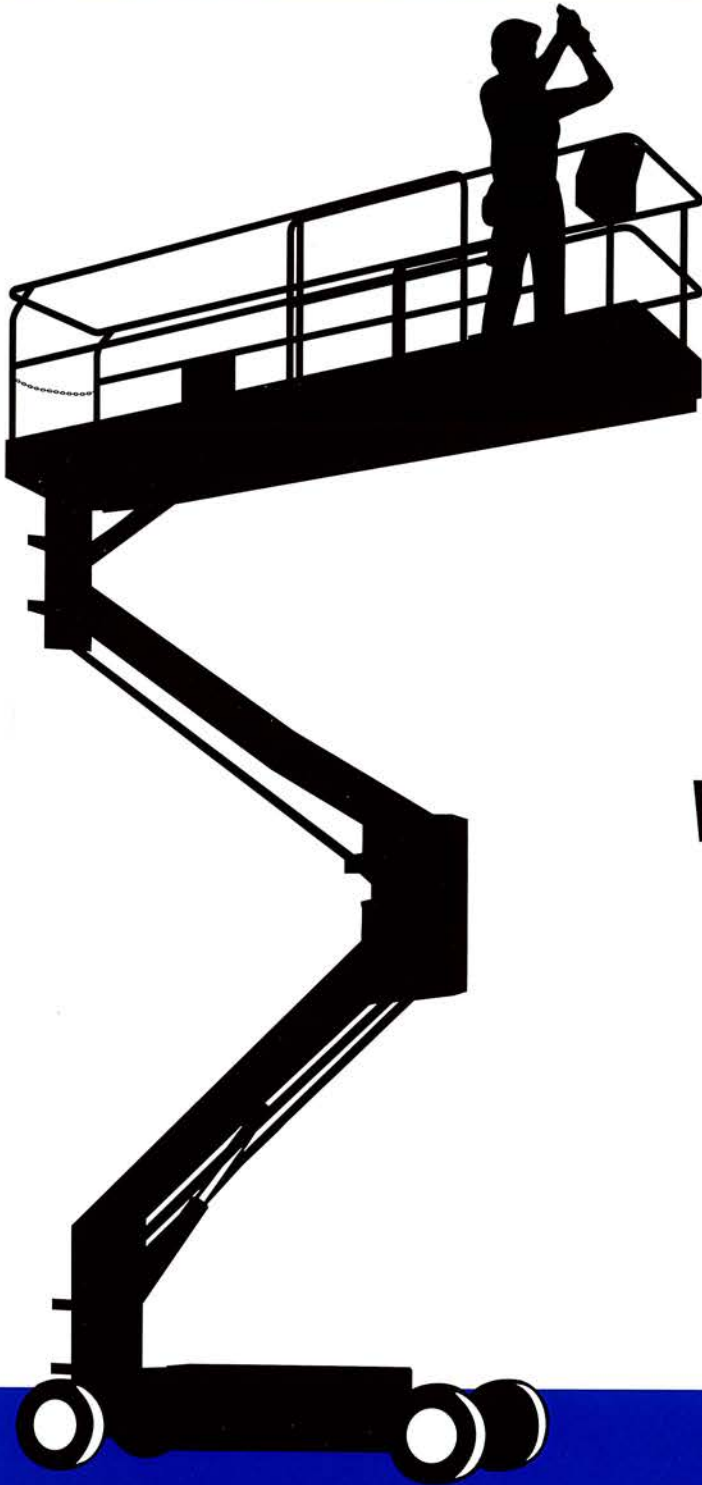

SL20

WORK PLATFORMS

**Service &
Parts Manual**

SERVICE & PARTS MANUAL

SL20 Series

Aerial Work Platform

Serial Numbers 8557 to Current

When contacting UpRight for service or parts information, be sure to include the MODEL and SERIAL NUMBERS from the equipment nameplate. Should the nameplate be missing the SERIAL NUMBER is also stamped on the top right side of the front chassis cross member.

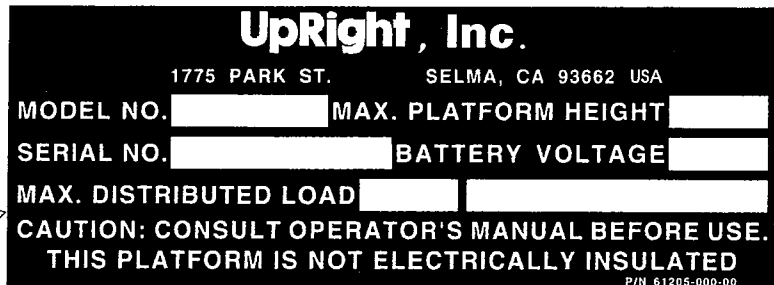
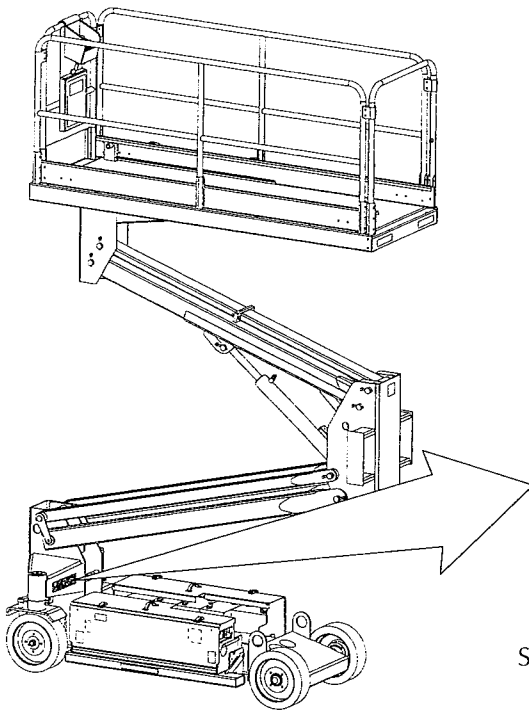

Stamped
Serial Number

UpRight

Call Toll Free in U.S.A.

1-800-926-LIFT

UpRight, Inc.
1775 Park Street
Selma, California 93662
TEL: 559/896-5150
FAX: 559/896-9012
PARTSFAX: 559/896-9244

P/N 101199-001

1.99 x x

Forward

Introduction

HOW TO USE THIS MANUAL

This manual is divided into 6 sections. The section number printed at the top corner of each page can be used as a quick reference guide.

SPECIAL INFORMATION



DANGER



Indicates the hazard or unsafe practice *will* result in severe injury or death.



WARNING



Indicates the hazard or unsafe practice *could* result in severe injury or death.



CAUTION



Indicates the hazard or unsafe practice could result in *minor* injury or property damage.

NOTES: Give helpful information.

WORKSHOP PROCEDURES

CAUTION: Detailed descriptions of standard workshop procedures, safety principles and service operations are not included. Please note that this manual does contain warnings and cautions against some specific service methods which could cause personal injury, or could damage a machine or make it unsafe. Please understand that these warnings cannot cover all conceivable ways in which service, whether or not recommended by UpRight, Inc., might be done, or of the possible hazardous consequences of each conceivable way, nor could UpRight Inc. investigate all such ways. Anyone using service procedures or tools, whether or not recommended by UpRight Inc., must satisfy themselves thoroughly that neither personal safety nor machine safety will be jeopardized.

All information contained in this manual is based on the latest product information available at the time of printing. We reserve the right to make changes at any time without notice. No part of this publication may be reproduced, stored in retrieval system, or transmitted, in any form by any means, electronic, mechanical, photocopying, recording, or otherwise, without the prior written permission of the publisher. This includes text, figures and tables.

Introduction & Specifications

1.0

General description and machine specifications.

Machine Preparation & Operation

2.0

Information on how to Operate the Work Platform and how to prepare for it for operation.

Maintenance

3.0

Preventative maintenance and service information.

Troubleshooting

4.0

Causes and solutions to typical problems.

Schematics

5.0

Schematics and valve block diagram with description and location of components.

Illustrated Parts Breakdown

6.0

Complete parts lists with illustrations.

Forward

NOTES

Table of Contents

Section No.	Page No.	Section No.	Page No.
1.0 Introduction & Specifications			
1.0 Introduction	1-1	3.6 Switch Adjustments	3-7
PURPOSE	1-1	Proximity (Figure 3-5)	3-7
SCOPE	1-1	Adjustment	3-7
1.1 General Information	1-1	Tilt Sensor (Figure 3-6)	3-7
DESCRIPTION	1-1	Introduction	3-7
PURPOSE AND LIMITATIONS	1-1	Adjustment	3-7
1.2 Specifications	1-2	Relay Controller Adjustment (Figure 3-7)	3-8
2.0 Machine Preparation & Operation			
Safety Rules	2-1	Dip Switch Setting, Toggle Controller (Figure 8)	3-8
2.0 Introduction	2-2	Dip switch Setting, Proportional Controller (Figure 8)	3-8
2.1 Preparation for Use	2-2	3.7 Hydraulic Manifold (Figure 3-9)	3-10
2.2 Preparation For Shipment	2-2	Removal	3-10
2.3 Forklifting Of Work Platform	2-2	Disassembly	3-10
2.4 Lifting Work Platform	2-2	Cleaning and Inspection	3-10
2.5 Transport	2-3	Assembly	3-10
2.6 Storage	2-3	Installation	3-10
Preservation	2-3	3.8 Hydraulic Power Unit (Figure 3-10)	3-12
Batteries	2-3	Removal	3-12
2.7 Pre-Operation and Safety Inspection	2-4	Installation	3-12
2.8 Operation	2-5	3.9 Hydraulic Drive Motors and Hubs (Figure 3-11) ...	3-12
Travel With Platform Lowered	2-5	Removal	3-12
Steering	2-5	Installation	3-12
Travel With Platform Elevated	2-6	3.10 Wheel Bearings (Figure 3-12)	3-13
Elevating Platform	2-6	Removal	3-13
Lowering Platform	2-6	Installation	3-13
Emergency Lowering	2-6	3.11 Brake Cylinder (Figure 3-13)	3-14
After Use Each Day	2-6	Removal	3-14
2.9 General Functioning	2-7	Installation	3-14
Driving	2-7	3.12 Steering Cylinder (Figure 3-14)	3-15
Steering	2-7	Removal	3-15
Raising and Lowering The Platform	2-7	Disassembly	3-15
Design Features	2-7	Cleaning and Inspection	3-15
2.10 Safety Rules and Precautions	2-8	Assembly and Installation (Figure 3-15)	3-15
2.11 Controls and Indicators	2-8	3.13 Lift Cylinder (Figure 3-17)	3-16
Platform/Controller	2-8	Removal	3-16
Chassis	2-9	Disassembly (Figure 3-17)	3-16
3.0 Maintenance			
3.0 Introduction	3-1	Cleaning and Inspection	3-16
Special Tools	3-1	Reassembly	3-16
3.1 Preventative Maintenance (Table 3-1)	3-1	Installation (Figure 3-16)	3-16
Preventative Maintenance Table Key	3-2	3.14 Pot Hole Cylinder (Figure 3-18)	3-18
Preventative Maintenance Report	3-2	Removal	3-18
3.2 Blocking Elevating Assembly (Figure 3-1)	3-3	Disassembly (Figure 3-19)	3-18
Installation	3-3	Cleaning and Inspection	3-18
Removal	3-3	Assembly and Installation	3-18
3.3 Battery Maintenance	3-4	Pothole Protection System Adjustment	3-19
Battery Inspection and Cleaning	3-4	3.15 Adjustable Compression Tube (Figure 3-20)	3-19
Battery Charging (Figure 3-2)	3-4	3.16 Electric Motor (Figure 3-21)	3-20
3.4 Lubrication	3-5	Troubleshooting	3-20
Hydraulic Oil Tank and Filter (Figure 3-3)	3-5	Disassembly	3-20
Fluid Level	3-5	Inspection	3-20
Oil and Filter Replacement	3-5	Reassembly	3-21
3.5 Setting Hydraulic Pressures (Figure 3-4)	3-6	3.17 Torque Specifications (Table 3-2)	3-22
Main Relief Valve (Figure 3-4)	3-6	fasteners	3-22
Steering Relief Valve	3-6	Hydraulic Components	3-22
Counterbalance Valves	3-6		

Table of Contents (cont'd.)

Section No.	Page No.
4.0 Troubleshooting	
4.0 Introduction	4-1
General Procedure	4-1
5.0 Schematics	
5.0 Introduction	5-1
Index	5-1
5.1 Electrical Schematic (Toggle)	5-2
5.2 Electrical Schematic (Proportional)	5-4
5.3 Hydraulic Schematic	5-6
6.0 Illustrated Parts Breakdown	
6.0 Introduction	6-1
6.1 Index	6-1

List of Illustrations

Fig.	Title	Page
1-1:	SL20 Series Work Platform	1-1
2-1:	Power Module, Left Side	2-2
2-2:	Transporting the SL20	2-2
2-3:	Chassis Control Module	2-4
2-4:	Emergency Lowering Valve	2-4
2-5:	Standard Controller	2-4
2-6:	Optional Proportional Controller	2-5
2-7:	Controls and Indicators	2-9
3-1:	Blocking the Elevating Assembly	3-3
3-2:	Battery Charger	3-4
3-3:	Hydraulic Oil Tank and Filter	3-5
3-4:	Hydraulic Manifold	3-6
3-5:	Proximity Switch	3-7
3-6:	Level Sensor Adjustment	3-7
3-7:	Relay Controller Adjustment	3-8
3-8:	Dip Switch Location	3-8
3-9:	Hydraulic Manifold, Exploded View	3-11
3-10:	Hydraulic Power Unit	3-12
3-11:	Hydraulic Drive Motor	3-12
3-12:	Wheel Bearings	3-13
3-13:	Brake Cylinder	3-14
3-14:	Steering Cylinder	3-15
3-15:	Steering Cylinder Assembly	3-15
3-16:	Lift Cylinder Installation	3-17
3-17:	Lift Cylinder Assembly	3-17
3-18:	Pothole Cylinder Installation	3-18
3-19:	Pothole Cylinder Assembly	3-18
3-20:	Compression Tube Assembly	3-19
3-21:	Electric Motor Service	3-20
5-1:	Electrical Schematic (Toggle)	5-3
5-2:	Electrical Schematic (Proportional)	5-5
5-3:	Hydraulic Schematic	5-7
5-4:	Hydraulic Manifold	5-7

List of Tables

Table	Title	Page
1-1:	Specifications	1-2
2-1:	Controls and Indicators	2-2
3-1:	Preventative Maintenance	3-2
3-2:	Bolt Torque	3-22
3-3:	Hydraulic Component Torque	3-22
3-4:	Routine Service	3-22
4-1:	Electric Truth Table	4-2
4-2:	Hydraulic Truth Table	4-3
5-1:	Electrical Schematic Legend (Toggle)	5-2
5-2:	Electrical Schematic Legend (Proportional)	5-4
6-3:	Hydraulic Schematic Legend	5-6

1.0 Introduction

PURPOSE

This manual provides illustrations and instructions for the operation and maintenance of the SL20 Series Work Platforms manufactured by UpRight, Inc. Selma, California. (See Figure 1-1).

SCOPE

This manual includes both operation and maintenance responsibilities concerning the SL20 Series Work Platform's readiness. The Maintenance Section covers scheduled maintenance, troubleshooting, repair, adjustment and replacement.

1.1 General Information

DESCRIPTION

The SL20 Series Work Platform is a self-propelled aerial work platform designed to be used as a means of elevating personnel and equipment and to provide a mobile work platform. They are designed to provide mobility with the platform in a raised or lowered position. Travel with the platform elevated is automatically limited to the low speed range.

PURPOSE AND LIMITATIONS

The objective of the SL20 Series Work Platforms is to provide a quickly deployable, self-propelled, variable height work platform. The elevating function shall only be used when the work platform is on a firm level work area. The work platform is intended to be self-propelled when in relatively close proximity to the work area.

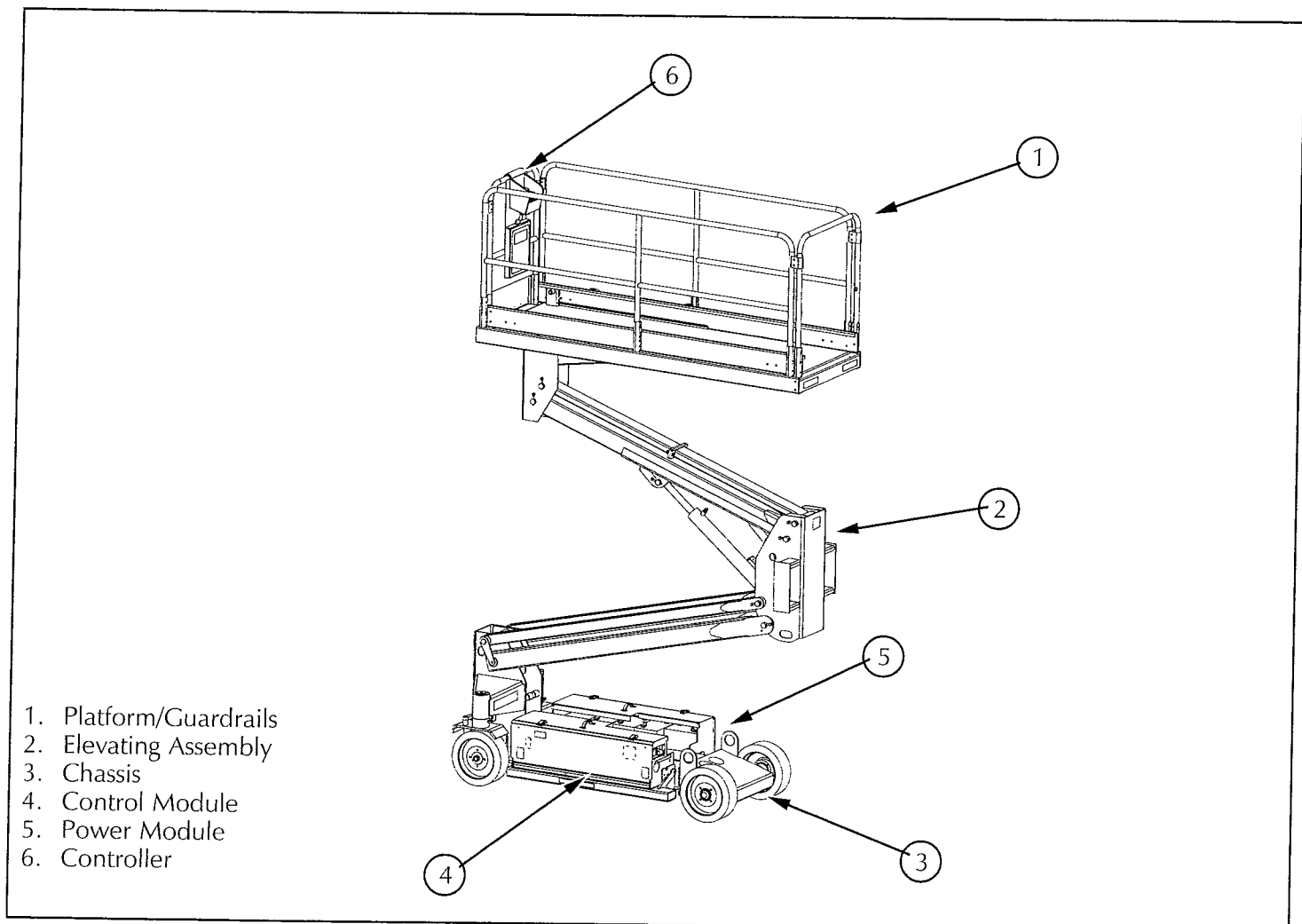

Figure 1-1: SL20 Series Work Platform

1.2 Specifications*

Table 1-1: Specifications

ITEM	SL20
Platform Size	27.75" x 96" [.70 m x 2.44 m] Inside Toeboards
Max. Platform Capacity Standard w/ Deck Extension w/o Deck Extension on Extension	650 lbs. [295 kg] 750 lbs. [340 kg] 250 lbs. [110 kg]
Max. No. of occupants Standard w/ Deck Extension w/o Deck Extension on Extension	2 People 3 People 1 Person
Height Working Height Max. Platform Height	26 ft. [7.92 m] 20 ft. [6.10 m]
Dimensions Weight Overall Width Overall Height Overall Length	3,127 lbs. [1423 kg] 33 in. [.84 m] 79 in. [2.01 m] 104.25 in. [2.65 m]
Driveable Height	20 ft. [6.10 m] Standard
Surface Speed-maximum Platform Lowered Platform Raised	2.3 mph [3.70 km/h] 0.7 mph [1.13 km/h]
Energy Source	24 Volt Battery Pack (4-220 Amp Hour, 6 Volt Batteries, Min. Wt. 62 lbs. each), 4 HP DC Electric Motor
System Voltage	24 Volt DC
Battery Charger	25 AMP
Battery Duty Cycle	25% for 8 Hours
Hydraulic Tank Capacity	4 Gallons [15.2 l]
Max. Hydraulic System Pressure	2800 psi [193 bar]
Hydraulic Fluid Normal temp. (>32 °F [0 °C]) Low temp. (-10 to 32 °F [-23 to 0 °C])	ISO #46 5W-20 Motor Oil
Lift System	Single Lift Cylinder
Standard Toggle Control System	Rotary Drive/Lift Selector Switch, Toggle Drive/Lift switch, Toggle Steering, and Red Mushroom Emergency Stop Switch
Optional Proportional Control System	Proportional Joystick Controller with Interlock Lever, Drive/Lift Switch, and Red Mushroom Emergency Stop Switch
Horizontal Drive	Dual Front Wheel Hydraulic Motors
Tires	15 in. [381 mm] Diameter Solid Rubber, non-marking
Parking Brake	Spring Applied, Hydraulic Release
Turning Radius	30 in. [0.76 m] Inside
Maximum Gradeability	25% [14°]
Wheel Base	73 in. [1.85 m]
Guardrails	38 in. [0.97 m]
Toeboard	6 in. [152 mm]

*Specifications subject to change without notice.

WARNING

All personnel shall carefully read, understand and follow all safety rules, operating instructions and the Scaffold Industry Association's MANUAL OF RESPONSIBILITIES of ANSI A92.6-1990 before performing maintenance on or operating any UpRight aerial work platform.

SAFETY RULES



NEVER operate the machine within ten feet of power lines. **THIS MACHINE IS NOT INSULATED.**

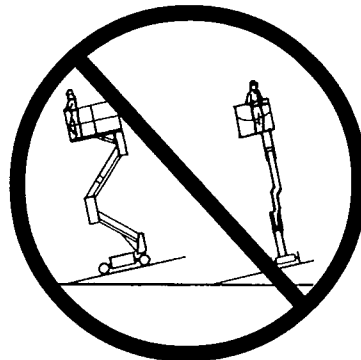

NEVER elevate the platform or drive the machine while elevated unless the machine is on firm level surface.

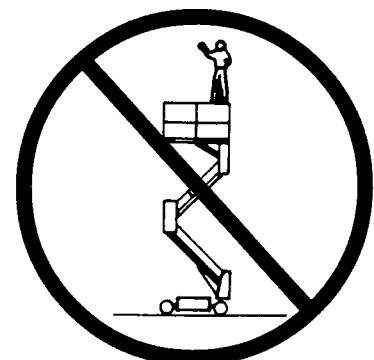

NEVER sit, stand or climb on guardrail or midrail.

NEVER operate the machine without first surveying the work area for surface hazards such as holes, drop-offs, bumps and debris before operating machine.

NEVER operate the machine if all guardrails are not properly in place and secured with all fasteners properly torqued.

SECURE chain across entrance after mounting platform.

NEVER use ladders or scaffolding on the platform.

NEVER attach overhanging loads or increase platform size.

LOOK up, down and around for overhead obstructions and electrical conductors.

DISTRIBUTE all loads evenly on the platform. See the back cover for maximum platform load.

NEVER use damaged equipment. (Contact UpRight for instructions. See toll free number on back cover.)

NEVER change operating or safety systems.

INSPECT the machine thoroughly for cracked welds, loose hardware, hydraulic leaks, damaged control cable, loose wire connections and wheel bolts.

NEVER climb down elevating assembly with the platform elevated.

NEVER perform service on machine while platform is elevated without blocking elevating assembly.

NEVER recharge batteries near sparks or open flame; batteries that are being charged emit highly explosive hydrogen gas.

AFTER USE secure the work platform against unauthorized use by turning key switch off and removing key.

NEVER replace any component or part with anything other than original UpRight replacement parts without the manufacturers written consent.

2.0 Introduction

This manual covers the SL20 Work Platforms. **This manual must be stored on the machine at all times.**

2.1 Preparation for Use

⚠	WARNING	⚠
STAND CLEAR when cutting the metal banding to avoid being cut if the banding snaps back.		

1. Remove the metal banding from the module covers and elevating assembly.
2. Remove the banding from the controller.
3. Lift the front of the machine and remove banding and blocks from front wheels.
4. Lower machine.
5. Connect the negative battery cable to the terminal (Figure 2-1).

2.2 Preparation For Shipment

1. Fully lower the platform.
2. Disconnect the negative (-) battery cable from the battery terminal (Figure 2-1).
3. Band the controller to the guardrail.
4. Band the elevating assembly to the frame just behind the front wheels.

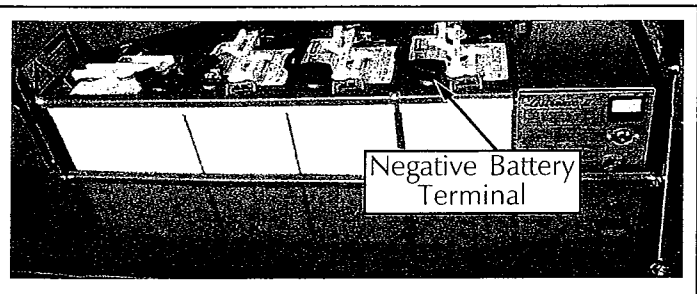

Figure 2-1: Power Module, Left Side

2.3 Forklifting Of Work Platform

NOTE: Forklifting is for transporting only.

⚠	CAUTION	⚠
See specifications for weight of work platform and be certain that forklift is of adequate capacity to lift platform.		

Forklift from the side by lifting under the chassis modules (Figure 2-2).

2.4 Lifting Work Platform

Secure straps to chassis lift points **only** (Figure 2-2).

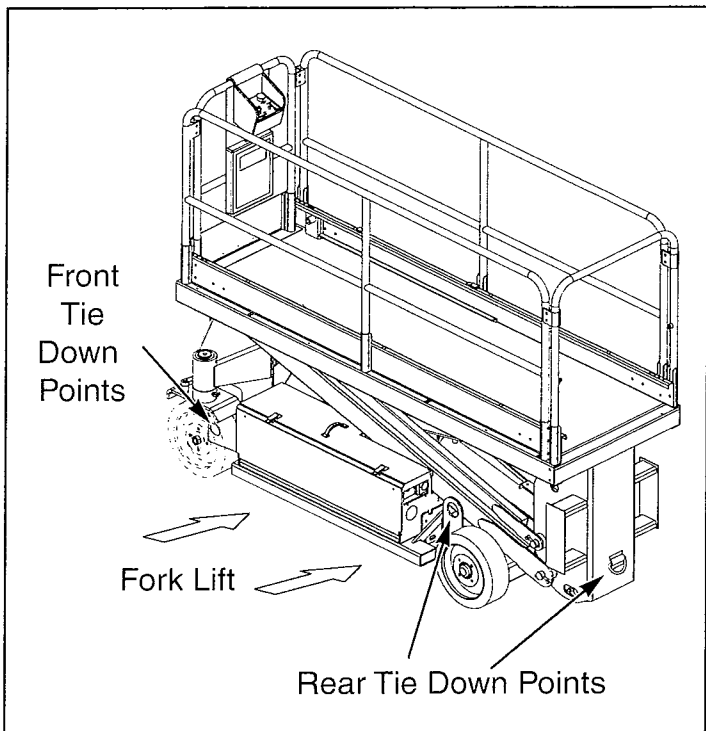

Figure 2-2: Transporting Work Platform

2.5 Transport

1. Maneuver the work platform into transport position and chock wheels.
2. Secure the work platform to the transport vehicle with chains or straps of adequate load capacity attached to the chassis tie down lugs (Figure 2-2).



CAUTION



Tie down lugs are not to be used to lift work platform.

Overtightening of chains or straps through tie down lugs may result in damage to work platform.

2.6 Storage

No preparation is required for normal storage. Regular maintenance per *Table 3-1* should be performed. If the work platform is to be placed in long term storage (dead storage) use the following preservation procedure.

PRESERVATION

1. Clean painted surfaces. If the paint surface is damaged, repaint.
2. Fill the hydraulic tank to operating level **with the platform fully lowered**, fluid should be visible on the dipstick.
3. Coat exposed portion of extended cylinder rod with a preservative such as multipurpose grease and wrap with barrier material.
4. Coat all exposed unpainted metal surfaces with preservative.

BATTERIES

1. Disconnect the battery ground cable and secure to the chassis.
2. Disconnect the remaining battery leads and secure to the chassis.
3. Remove the batteries and place in alternate service.

2.7 Pre-Operation and Safety Inspection

Read, understand and follow all safety rules and operating instructions and then perform the following steps each day before use.

1. Open module covers and inspect for damage, oil leaks or missing parts.
2. Check the level of the hydraulic oil with the platform fully lowered. Oil should be visible to full line on tank. Add ISO #46 hydraulic oil if necessary.
3. Check that fluid level in the batteries is correct (See *Battery Maintenance*, Section 3.3).
4. Verify batteries are charged.
5. Check that AC extension cord has been disconnected from charger.
6. Carefully inspect the entire work platform for damage such as cracked welds or structural members, loose or missing parts, oil leaks, damaged cables or hoses, loose connections and tire damage.
7. Move machine, if necessary, to unobstructed area to allow for full elevation.
8. Pull out on chassis and platform emergency stop switches to turn ON (Figure 2-3 and 4 or 5).
9. Turn the Chassis Key Switch (Figure 2-3) to **CHASSIS**.
10. Push chassis lift switch (Figure 2-3) to **LIFT** position and fully elevate platform.

11. Visually inspect the elevating assembly, lift cylinder, cables and hoses for damage or erratic operation. Check for missing or loose parts.
12. Verify that pot hole protection supports have rotated into position under each module.
13. Partially lower the platform by pushing chassis lift switch to **LOWER**, and check operation of the audible lowering alarm.
14. Pull out on the emergency lowering knob (Figure 2-4) to check for proper operation. Once the platform is fully lowered, release the knob.
15. Turn the chassis key switch (Figure 2-3) to **PLATFORM**.

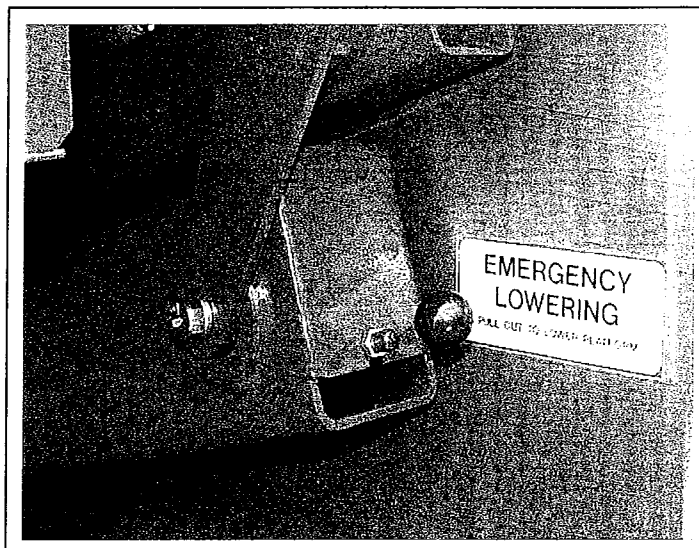

Figure 2-4: Emergency Lowering Valve Knob

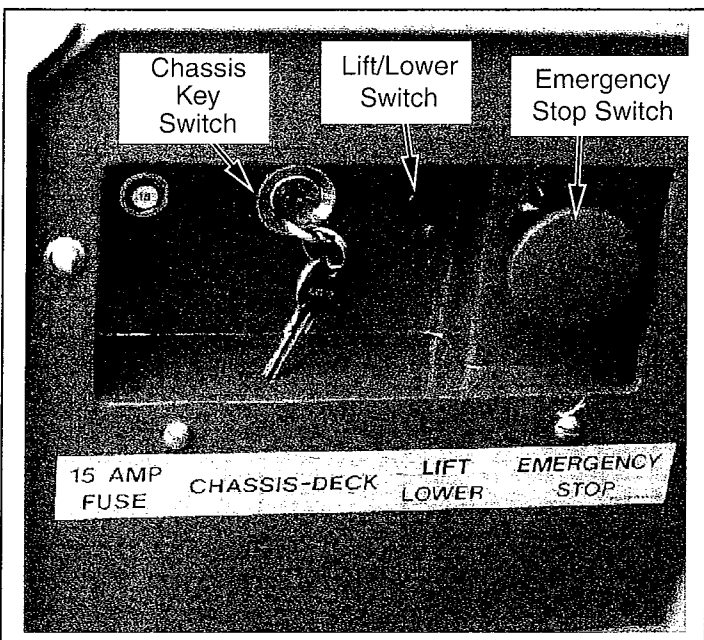

Figure 2-3: Chassis Control Module

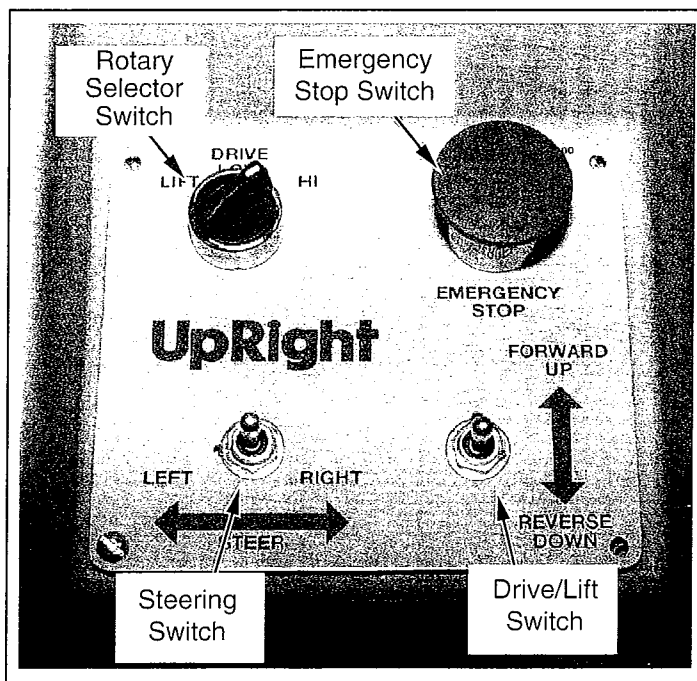

Figure 2-5: Standard Controller

16. Close and secure module covers.
17. Check that route is clear of persons, obstructions, holes and drop-offs, level and capable of supporting the wheel loads.
18. After mounting platform latch chain across entrance.
19. STANDARD MODELS (Figure 2-5)
 - A. Position rotary selector switch (Figure 2-3) to DRIVE LOW.
 - B. While depressing the foot pedal , position drive/lift switch to **FORWARD** then **REVERSE** to check for speed and directional control.
 - C. Position rotary selector switch to DRIVE HIGH and repeat step 19B.
20. OPTIONAL PROPORTIONAL CONTROLLER (Figure 2-6)
 - A. Position rotary selector switch to drive.
 - B. While holding in on the interlock switch, position handle **FORWARD** then **REVERSE** to check for speed and directional control.
21. Push steering switch RIGHT then LEFT to check for steering control.
22. Push the emergency stop switch button.

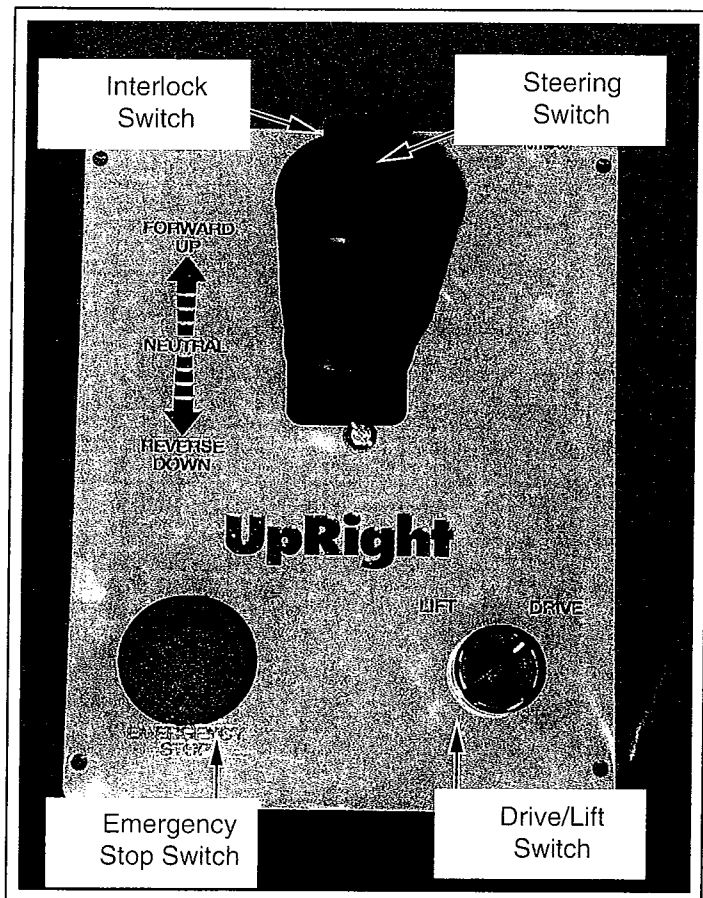

Figure 2-6: Optional Proportional Controller

2.8 Operation

Before operating work platform ensure that pre-operation and safety inspection has been completed, any deficiencies have been corrected and the operator has been thoroughly trained on this machine. The operator must read, fully understand and follow this Operator Manual and the Scaffold Industry Association's Manual of Responsibilities of ANSI A92.6-1990.

Travel With Platform Lowered

1. Check that route is clear of people, obstructions, holes and drop-offs, is level and is capable of supporting wheel loads.
2. Verify chassis key switch is turned to **PLATFORM** and chassis emergency stop switch is ON, pull button out.
3. After mounting platform latch chain across entrance.
4. Check clearances above, below and to the sides of platform.
5. Pull controller emergency stop button out to ON position. When button is pushed down emergency stop switch will automatically go to OFF position.
6. Position drive/lift switch to **DRIVE**.
7. STANDARD MODELS (Figure 2-5)

While depressing the foot pedal, push control switch to **FORWARD** or **REVERSE** position to travel in the desired direction. The machine will accelerate to maximum speed for current toggle setting.
8. OPTIONAL PROPORTIONAL CONTROLLER (Figure 2-6)

Holding in on the interlock switch, position handle **FORWARD** or **REVERSE** to travel in the desired direction. The machine will move faster or slower depending on the position of the handle.

Steering

1. Position rotary selector switch to **DRIVE**.
2. STANDARD MODELS (Figure 2-5)

While depressing the foot pedal, push the steering switch to **RIGHT** or **LEFT** to turn wheels in the desired direction. Observe the tires while maneuvering the work platform to ensure proper direction.
3. PROPORTIONAL CONTROLLER MODELS (Figure 2-6)

Holding in on the interlock switch, push the steering switch to **RIGHT** or **LEFT** to turn wheels in the desired direction. Observe the tires while maneuvering the machine to ensure proper direction.

NOTE: Steering is not self-centering. Wheels must be returned to straight ahead position by operating steering switch.

Elevating Platform

1. Position rotary selector switch to **LIFT**.
2. While depressing the foot pedal (interlock switch on proportional controller), push control switch to **UP**.
3. If the machine is not level the tilt alarm will sound and the machine will not lift or drive. **If the tilt alarm sounds the platform must be lowered and the machine moved to a level location before attempting to re-elevate the platform.**

NOTE: Pothole protection will automatically lower when platform is raised and automatically raise when machine is lowered completely and driven.

Travel With Platform Elevated



NOTE: Work platform will travel at reduced speed when platform is elevated.

1. Check that route is clear of persons, obstructions, holes and drop-offs, is level and capable of supporting the wheel loads.
2. Check clearances above, below and to the sides of platform.
3. Position rotary selector switch to **DRIVE** position.
4. While depressing the foot pedal (interlock switch on proportional controllers), push drive/lift switch to **FORWARD** or **REVERSE** for desired direction of travel.
5. If the machine is not level the tilt alarm will sound and the machine will not lift or drive. **If the tilt alarm sounds the platform must be lowered and the machine moved to a level location before attempting to re-elevate the platform.**

Lowering Platform

1. Position rotary selector switch to **LIFT**.
2. While depressing the foot pedal (interlock switch on proportional controllers), pull back on drive/lift switch.

Emergency Lowering

	WARNING	
If the platform should fail to lower, NEVER climb down the elevating assembly.		
The emergency lowering valve knob is located at the front of the chassis (Figure 2-4).		

1. Open the emergency lowering valve by pulling and holding the knob.
2. To close, release the knob. The platform will not elevate if the emergency lowering valve is open.

After Use Each Day

1. Ensure that the platform is fully lowered.
2. Park the machine on level ground, preferably under cover, secure against vandals, children or unauthorized operation.
3. Turn the key switch to **OFF** and remove the key to prevent unauthorized operation.

2.9 General Functioning

Refer to the Hydraulic and Electrical Schematics, Section 5.

The battery powered electric motor directly drives a single section hydraulic pump. The low section supplies oil under pressure to operate steering, the high section supplies oil under pressure to operate the other work platform functions. The oil flow is directed to the different functions by electrically activated solenoid valves.

Driving

Standard Toggle Controller

1. Pull out both Emergency Stop Switches. Turn key switch to **Deck**.
2. Set rotary selector switch to **Drive Lo** or **Drive Hi**.
3. Depress foot switch and push drive/lift toggle switch **Forward** or **Reverse**.
3. Machine will drive at "creep" speed if platform is elevated.

Optional Proportional Controller

1. Pull out both Emergency Stop Switches. Turn key switch to **Deck**. Set Drive/Lift switch to **Drive**.
2. Depress interlock lever and slowly push joystick **Forward** or **Reverse**. Machine speed is regulated by the angle of the joystick.
3. Machine will drive at "creep" speed if the platform is elevated.

Steering

Standard Toggle Controller

1. Push the **Steering** toggle switch left or right.

Optional Proportional Controller

1. Move the **Steering** rocker switch (located on top of the joystick) left or right.

Raising the Platform

Standard Toggle Controller

1. Set rotary selector switch to **Lift**.
2. Push drive/lift toggle switch **Up** or **Down**.
3. During the last 6-8 in. (15-20 cm) of platform lowering, the lift cylinder internal cushion orifice will slow the platform to cushion speed.

Optional Proportional Controller

1. Set Drive/Lift switch to **Lift**.
2. Depress interlock lever and slowly push joystick **UP** or **Down**. Lift speed is regulated by the angle of the joystick
3. During the last 6-8 in. (15-20 cm) of platform lowering, the lift cylinder internal cushion orifice will slow the platform to cushion speed.

Emergency Down Valve

Lowering the platform manually with the emergency down valve allows the oil to flow out of the lift cylinder and lower the platform, but there is no down alarm.

DESIGN FEATURES

The SL20 Series Work Platform has the following features:

- The drive speed is limited to creep speed when operating the work platform while the platform is elevated.
- The platform descent rate is controlled by an orifice (fixed speed). In the last 6-8 inches (15-20 cm) of platform lowering, the oils flows through the lift cylinder internal cushion orifice to slow the platform even further (cushion speed). The lift cylinder is equipped with a holding valve to prevent descent should a hose rupture.
- The chassis is equipped with active pothole protection system.
- Parking brake is automatically engaged when the machine comes to a full stop or if power is lost.
- The chassis controls and controller are equipped with an emergency stop switch for stopping all powered functions.
- Standard Toggle Controller: The foot switch must be depressed for the controller to function.
- Optional Proportional Controller: The interlock lever must be depressed for the controller to function.
- The controller is guarded to prevent inadvertent operation.
- An alarm is provided to signal when the platform is lowering.
- A lift switch is located in the control module on the left side of the chassis for lifting and lowering the platform from ground level.
- The tilt alarm (600 Hz) is activated on slopes of 2 degrees side to side and fore and aft when the machine is elevated.
- An emergency lowering valve is provided at the lower left boom at the front of the machine to lower the platform in the event electrical power is lost.

2.10 Safety Rules and Precautions

Before using the SL20 Series Work Platform:

NEVER operate the machine without first surveying the work area for surface hazards such as holes, drop-offs, bumps and debris before operating machine.

NEVER operate the machine if all guardrails are not properly in place and secured with all fasteners properly torqued.

SECURE chain across entrance after mounting platform.

NEVER use ladders or scaffolding on the platform.

NEVER attach overhanging loads or increase platform size.

LOOK up, down and around for overhead obstructions and electrical conductors.

DISTRIBUTE all loads evenly on the platform. See the back cover for maximum platform load.

NEVER use damaged equipment. (Contact UpRight for instructions. See toll free number on back cover.)

NEVER change operating or safety systems.

INSPECT the machine thoroughly for cracked welds, loose hardware, hydraulic leaks, damaged control cable, loose wire connections and wheel bolts.

NEVER climb down elevating assembly with the platform elevated.

NEVER perform service on machine while platform is elevated without blocking elevating assembly.

NEVER recharge batteries near sparks or open flame; batteries that are being charged emit highly explosive hydrogen gas.

AFTER USE secure the work platform against unauthorized use by turning key switch off and removing key.

NEVER replace any component or part with anything other than original UpRight replacement parts without the manufacturers written consent.

2.11 Controls and Indicators

The controls and indicators for operation of the SL20 Series Work Platform are shown in Figure 2-7. The name and function of each control and indicator are listed in Table 2-1. The index numbers in the figure correspond to the index numbers in the table. **The operator shall know the location of each control and indicator and have a thorough knowledge of the function and operation of each before attempting to operate the unit.**

Table 2-1: Controls and Indicators

Platform/Controller

INDEX NO.	NAME	FUNCTION
1	INTERLOCK LEVER (Proportional)	Provides power to the controller only when depressed, preventing accidental activation of the controller.
2	EMERGENCY STOP SWITCH	Push red button to cut off power to all functions (OFF). Pull out to provide power (ON).
3	CONTROL LEVER (Proportional)	Move joystick forward or backwards to proportionally control drive/lift speeds depending on position of drive/lift switch.
4	STEERING SWITCH (Proportional)	Moving the momentary rocker switch right or left steers the work platform in that direction. Although the steering switch is self centering the steering system is not. The wheels must be steered back to straight.
5	DRIVE/LIFT SWITCH (Proportional)	Selecting DRIVE allows the work platform to move forward or reverse. Selecting LIFT allows the platform to raise or lower.
6	DRIVE/LIFT ROTARY SELECTOR SWITCH (Standard)	Selecting DRIVE LO allows the work platform to move forward or reverse in low speed. Selecting DRIVE HI allows the work platform to move forward or reverse in high speed. Selecting LIFT allows the platform to raise or lower.
7	STEERING SWITCH (Standard)	Moving the momentary toggle switch right or left steers the work platform in that direction. Although the steering switch is self centering the steering system is not. The wheels must be steered back to straight.
8	DRIVE/LIFT SWITCH (Standard)	Move the toggle switch forward or backward to lift or lower, drive forward or backward, depending on position of drive/lift switch.

Table 2-1: Controls and Indicators (cont'd.)

Chassis

INDEX NO.	NAME	FUNCTION
9	EMERGENCY STOP SWITCH	Push red button to cut off power to all functions (OFF). Pull out to provide power (ON).
10	KEY SWITCH	Turn key clockwise to DECK to provide power to controller and counterclockwise to CHASSIS to provide power to chassis controls.
11	CHASSIS LIFT SWITCH	Push switch to UP to lift the platform and to DOWN to lower the platform.
12	EMERGENCY LOWERING VALVE	Pull knob out to lower the platform. Release knob to close valve. The platform cannot be raised unless this valve is closed.

INDEX NO.	NAME	FUNCTION
13*	DOWN ALARM (60Hz)	Produces an audible signal when the platform is lowering during normal operation. If the emergency lowering valve is used the alarm does not sound.
	TILT ALARM (600 Hz)	Produces an audible signal when the platform is elevated and on a slope of 2° side to side or fore and aft.
	* Both alarms are in the same unit.	
14*	VOLT/HOUR METER (OPTION)	Indicates state of battery charge and hours electric motor has operated.
	*Photo indicates location for optional Volt/Hour Meter (not shown).	

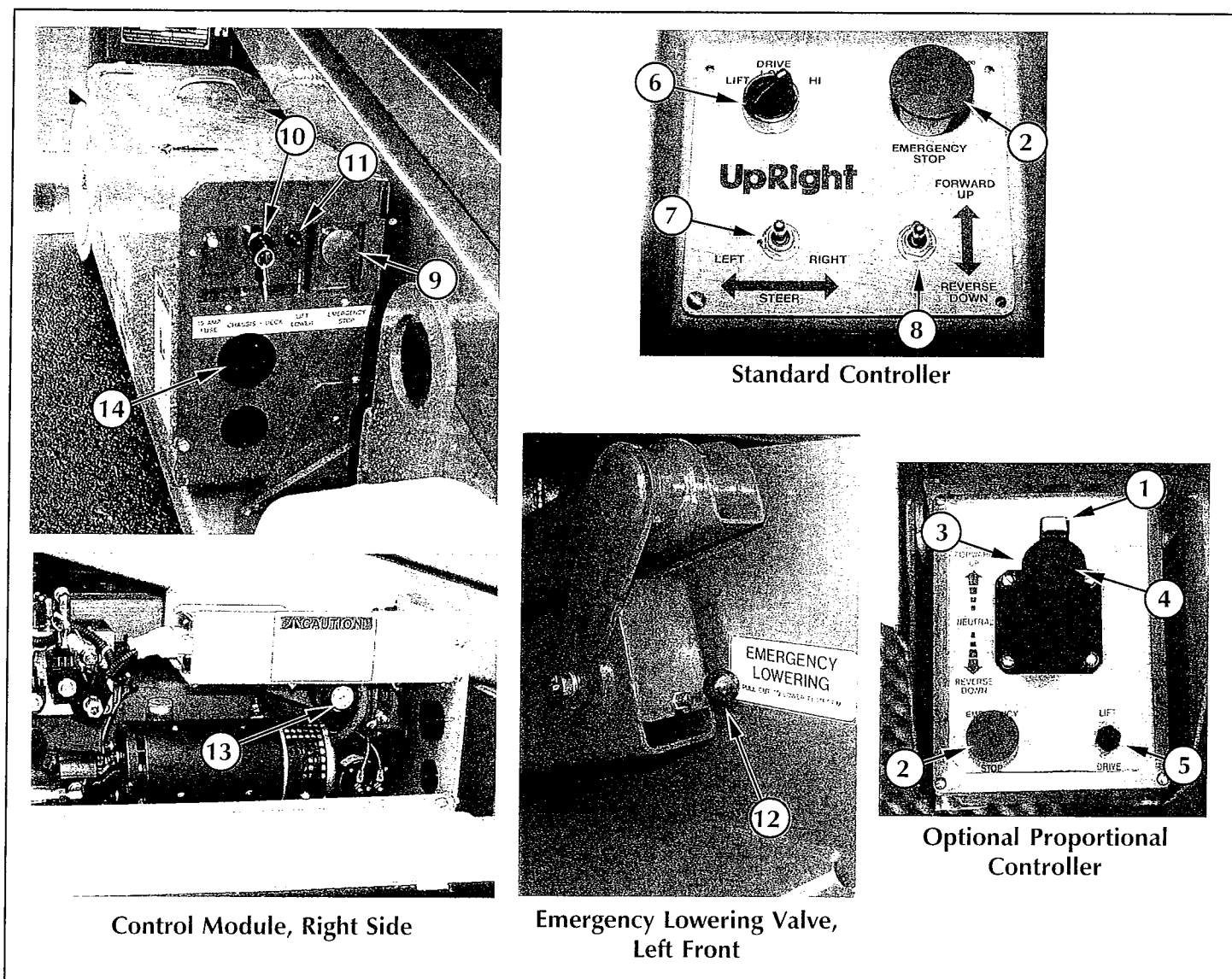

Figure 2-7: Controls and Indicators

NOTES:

3.0 Introduction

This section contains instructions for the maintenance of the SL20 Series Work Platforms. Procedures for the operational checkout adjustment, scheduled maintenance, and repair/removal are included.

Referring to *Section 2* will aid in understanding the operation and function of the various components and systems of the SL20 Series Work Platforms and help in diagnosing and repair of the machine.

SPECIAL TOOLS

The following is a list of special tools that are required to perform certain maintenance procedures. These tools may be purchased from your dealer.

Description	Part Number
Tilt Sensor Adjusting Tool	030622-000
Inclinometer	010119-000
Gauge, 0-207 bar (0-3000 psi)	014124-030
Fitting, Quick Disconnect	063965-002
Deutsch Field Kit (Small)	030899-000
Deutsch Field Kit (Large)	030898-000

3.1 Preventative Maintenance (Table 3-1)

The complete inspection consists of periodic visual and operational checks, together with all necessary minor adjustments to assure proper performance. Daily inspection will prevent abnormal wear and prolong the life of all systems. The inspection and maintenance schedule is to be performed at regular intervals. Inspection and maintenance shall be performed by personnel who are trained and familiar with mechanical and electrical procedures. Complete descriptions of the procedures are in the text following the table.

⚠ WARNING ⚠

Before performing preventative maintenance familiarize yourself with the operation of the machine.

Always use the elevating assembly brace whenever it is necessary to enter the elevating assembly when the platform is elevated.

The Preventative Maintenance table has been designed to be used for machine service and maintenance repair. **Please copy the following page and use this table as a checklist when inspecting a machine for service.**

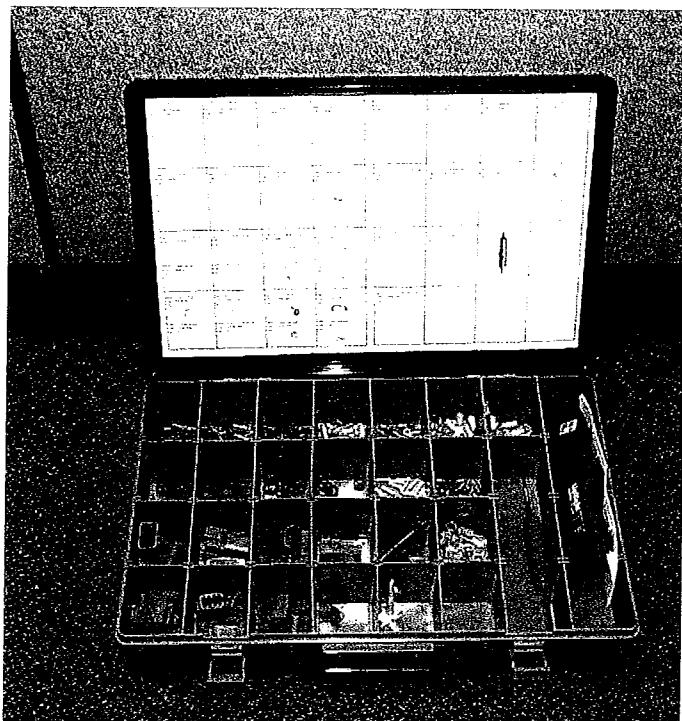

Large Deutsch Field Kit

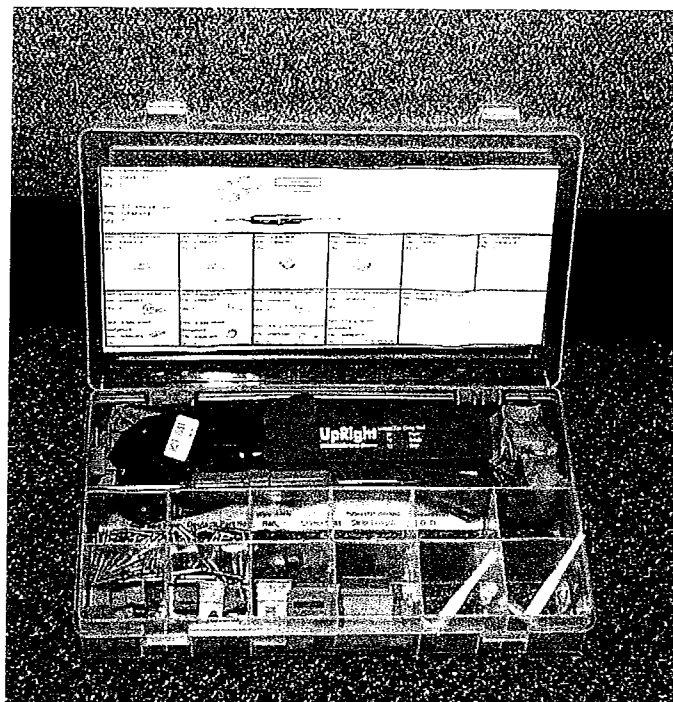

Small Deutsch Field Kit

Preventative Maintenance Table Key

Interval

Daily=each shift or every day

50h/30d=every 50 hours or 30 days

250h/6m=every 250 hours or 6 months

1000h/2y=every 1000 hours or 2 years

Y=Yes/Acceptable

N=No/Not Acceptable

R=Repaired/Acceptable

Preventative Maintenance Report

Date: _____
Owner: _____
Model No: _____ Serial No: _____
Serviced By: _____
Service Interval: _____

Table 3-1: Preventative Maintenance

COMPONENT	INSPECTION OR SERVICES	INTERVAL	Y	N	R
Battery System	Check electrolyte level	Daily			
	Check battery cable condition	Daily			
	Charge batteries	Daily			
	Check charger condition & operation	Daily			
	Check specific gravity	50h/30d			
	Clean exterior	250h/6m			
	Clean terminals	250h/6m			
Hydraulic Oil	Check oil level	Daily			
	Change filter	250h/6m			
	Drain and replace oil (ISO #46)	1000h/2y			
Hydraulic System	Check for leaks	Daily			
	Check hose connections	50h/30d			
	Check for exterior wear	50h/30d			
Emergency Hydraulic System	Open the emergency lowering valve and check for proper operation	Daily			
Controller	Check condition & operation	Daily			
Control Cable	Check the exterior of the cable for pinching, binding or wear	Daily			
Platform Deck and Rails	Check fasteners for proper torque	Daily			
	Check welds for cracks	Daily			
	Check condition of deck	Daily			
	Check entry way closure	Daily			
Hydraulic Pump	Check for hose fitting leaks	Daily			
	Wipe clean	50h/30d			
	Check for leaks at mating surfaces	50h/30d			
	Check mounting bolts for proper torque	50h/30d			
Drive Motors	Check for operation and leaks	Daily			
Steering System	Lubricate pivot pins	250h/6m			
	Lubricate king pins	250h/6m			
	Check steering cylinder for leaks	50h/30d			
	Check hardware & fittings for proper torque	250h/6m			
Elevating Assembly	Inspect for structural cracks	Daily			
	Check pivot bearings for wear	50h/30d			
	Check pivot pin retaining rings	50h/30d			
	Check elevating assembly for bending	250h/6m			
Chassis	Check hoses for pinch or rubbing points	Daily			
	Check welds for cracks	Daily			
	Check tires for damage	Daily			
	Check component mounting for proper torque	250h/6m			
	Check cylinder rod for wear	50h/30d			
Lift Cylinder	Check pivot pin retaining hardware	50h/30d			
	Check seals for leaks	50h/30d			
	Check pivot points for wear	50h/30d			
	Check fittings for proper torque	50h/30d			
	Perform pre-operation inspection	Daily			
Entire Unit	Check for and repair collision damage	Daily			
	Lubricate	50h/30d			
	Check fasteners for proper torque	250h/6m			
	Check for corrosion-remove and repaint	250h/6m			
Labels	Check for peeling, missing, or unreadable labels & replace	Daily			

3.2 Blocking Elevating Assembly (Figure 3-1)

⚠ DANGER ⚠

Never perform service on the work platform while platform is elevated without first blocking the Elevating Assembly.

DO NOT stand in Elevating Assembly area while installing or removing block.

DO NOT block elevating assembly with a load in the platform.

Use a wood block to block elevating assembly.

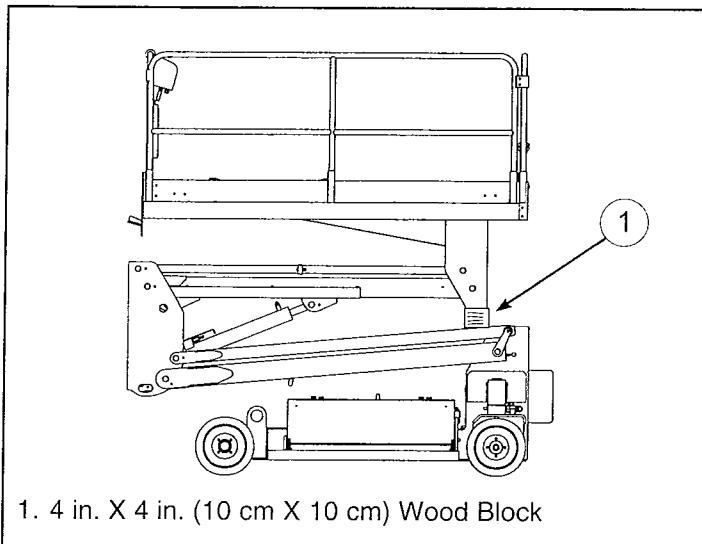

Figure 3-1: Blocking the Elevating Assembly

Installation



1. Park the work platform on firm, level ground.
2. Position chassis lift switch to **LIFT** and elevate platform approximately two (.6 m) feet.
3. Place 4 in. X 4 in. (10 cm X 10 cm) wood block as shown in Figure 3-1.
4. Push chassis lift switch to **LOWER** position and gradually lower platform until boom is supported by the wood block.

Removal

1. Push chassis lift switch to **LIFT** position and gradually raise platform until wood block can be removed.
2. Remove wood block.
3. Push chassis lift switch to **LOWER** position and completely lower platform.
4. Close control module cover.



3.3 Battery Maintenance

Electrical energy for the motor is supplied by four 6-volt batteries wired in series for 24 volts DC. Proper care and maintenance of the batteries and motor will ensure maximum performance from the work platform.

 WARNING 
<p>Hazard of explosive gas mixture. Keep sparks, flame and smoking materials away from batteries.</p> <p>Always wear safety glasses when working with batteries.</p> <p>Battery fluid is highly corrosive. Rinse away any spilled fluid thoroughly with clean water.</p> <p>Always replace batteries with UpRight batteries or manufacturer approved replacements weighing 62 lbs. [28.12 kg] each.</p>

BATTERY INSPECTION AND CLEANING

Check battery fluid level daily, especially if work platform is being used in a warm, dry climate. If required add distilled water only, use of tap water with high mineral content will shorten battery life.



 CAUTION 
<p>If battery water level is not maintained, batteries will not fully charge, creating a low discharge rate which will damage motor/pump unit and void warranty.</p>

Batteries should be inspected periodically for signs of cracks in the cases, electrolyte leakage and corrosion of the terminals. Inspect cables for worn spots or breaks in the insulation and for broken cable terminals.

Clean batteries that show signs of corrosion at the terminals or onto which electrolyte has overflowed during charging. Use a baking soda solution to clean the batteries, taking care not to get the solution inside the cells. Rinse thoroughly with clear water. Clean battery and cable contact surfaces to a bright metal finish whenever a cable is removed.

BATTERY CHARGING (Figure 3-2)

Charge batteries at end of each work shift or sooner if batteries have been discharged.

 CAUTION 
<p>Charge batteries in a well ventilated area. Do not charge batteries when the work platform is in an area containing sparks or flames.</p> <p>Permanent damage to batteries will result if batteries are not immediately recharged after discharging.</p> <p>Never leave charger operating unattended for more than two days.</p> <p>Never disconnect cables from batteries when charger is operating.</p> <p>Keep charger dry.</p>

1. Check battery fluid level. If electrolyte level is lower than 3/8 in. [10mm] above plates add **distilled** water only.
2. The plug for the battery charger is located at the right side of the power module. Connect extension cord (12 gauge [1.5 mm²] conductor minimum and 50 ft. [15 m] in length maximum) to the charger plug. Connect other end of extension cord to properly grounded outlet of proper voltage and frequency.
3. Charger turns on automatically after a short delay, the ammeter will indicate charging current.
4. Charger turns off automatically when batteries are fully charged.

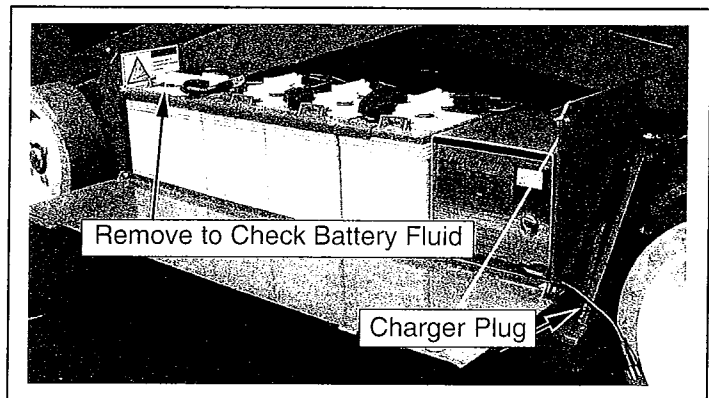

Figure 3-2: Battery Charger

3.4 Lubrication

The SL20 is designed with maintenance free bearings. Only the wheel bearings require lubrication. Refer to section 3.10 for wheel bearing maintenance.

HYDRAULIC OIL TANK AND FILTER (Figure 3-3)

Fluid Level

The fluid level is visible through the label on the plastic tank. With platform fully lowered, oil should level should be at MAX. **DO NOT** fill above the upper line or when the platform is elevated.

Oil and Filter Replacement

1. Operate the work platform for 10-15 minutes to bring the hydraulic oil up to normal operating temperature.



CAUTION



The hydraulic oil may be of sufficient temperature to cause burns. Wear safety gloves and safety glasses when handling hot oil.

2. Provide a suitable container to catch the drained oil. Hydraulic tank has a 4 U.S. gal (15 l) capacity.
3. Remove the drain plug under the tank and allow all oil to drain.
4. Clean the magnetic drain plug and reinstall.

5. Fill the hydraulic reservoir with hydraulic oil (see Section 1.2) until the oil is visible on the dipstick, do not fill above the lower line on the dipstick. Hydraulic tank has a 4 U.S. gal (15 l) capacity.
6. Unthread the filter.
7. Apply a thin film of clean hydraulic oil to the gasket of the replacement filter.
8. Thread the replacement filter until the gasket makes contact, then rotate the filter 3/4 of a turn further.

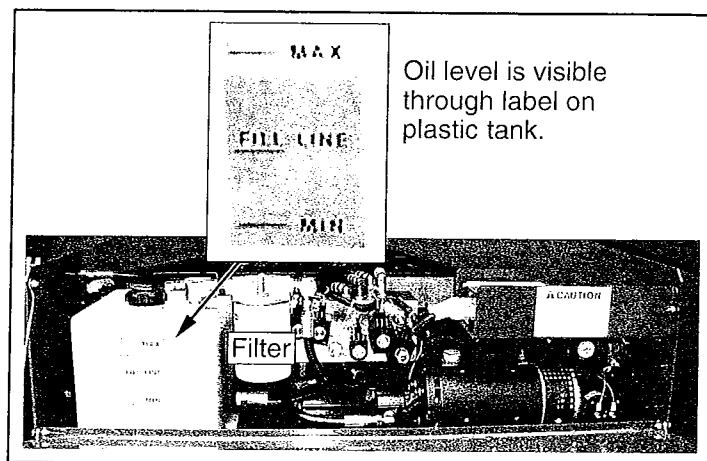

Figure 3-3: Hydraulic Oil Tank and Filter

3.5 Setting Hydraulic Pressures (Figure 3-4)

Check the hydraulic pressures whenever the pump, manifold or relief valve have been serviced or replaced.

⚠ WARNING ⚠

The hydraulic oil may be of sufficient temperature to cause burns. Wear safety gloves and safety glasses when handling hot oil.

The oil in the hydraulic system is under very high pressure which can easily cause severe cuts. **Obtain medical assistance immediately if cut by hydraulic oil.**

MAIN RELIEF VALVE (Figure 3-4)

1. Operate the hydraulic system 10-15 minutes to warm the oil.
2. Loosen locknut or remove cover on the main relief valve and turn adjusting screw counterclockwise two full turns.
3. Place the maximum rated load, see Table 1-1, on the platform.

4. Turn the chassis key switch to **CHASSIS**. Position the chassis lift switch to **LIFT** position and hold it there.
5. Slowly turn the main relief valve adjusting screw clockwise to increase the pressure until the platform just begins to raise. The pressure should be approximately 2750 psi [190 bar].
6. Release the chassis lift switch. Tighten locknut or replace main relief valve cover.

STEERING RELIEF VALVE

1. Operate the work platform for 10-15 minutes to bring the hydraulic oil up to normal operating temperature.
2. Install gauge in pressure gauge port.
3. Loosen locknut or remove cover on the steering relief valve and turn adjusting screw counterclockwise two full turns.
4. While one person holds the steering switch to steer the wheels fully to the left, slowly turn the steering relief valve adjusting screw clockwise to increase the pressure until the gauge reads 1000 psi [69 bar].
5. Tighten locknut or replace steering relief valve cover and torque to 6 Ft/Lbs [8 Nm].
6. Remove gauge and replace cap.

COUNTERBALANCE VALVE

1. Operate the work platform for 10-15 minutes to bring the hydraulic oil up to normal operating temperature.
2. Remove pressure gauge port cap and install the pressure gauge assembly.
3. Disconnect proximity switch.
4. Lift work platform and block front wheels off ground.
5. Loosen the locknut on counterbalance valve.
6. With the chassis key switch on **DECK** and the drive/lift switch in **DRIVE**, depress the interlock lever and slowly pull the control lever to **REVERSE** to drive the wheels.
7. Adjust the counterbalance valve by turning the adjustment screw until the pressure gauge indicates 800 to 1000 psi [55 to 69 bar].
8. Tighten locknut on valve to 6 Ft/Lbs [8 Nm].
9. Check the setting by slowly moving the control lever **FORWARD**, then **REVERSE** checking the gauge to ensure pressures are properly set. Readjust as needed.
10. Remove block and lower work platform to ground.

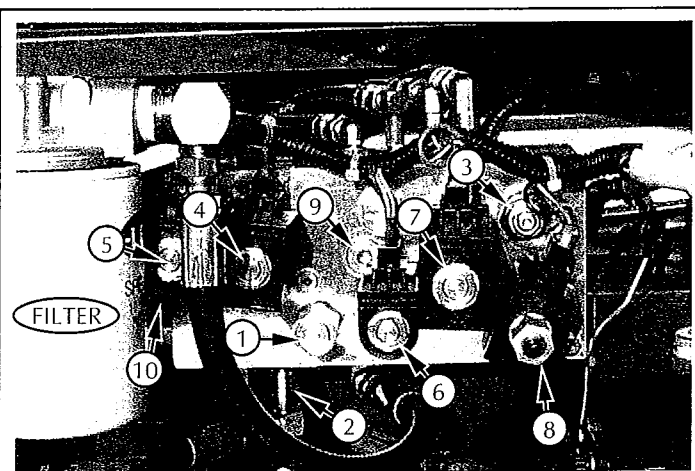

- | | |
|--------------------------|---|
| 1. Main Relief Valve | 6. Pothole Poppet Valve |
| 2. Steering Relief Valve | 7. Drive Solenoid |
| 3. Counterbalance Valve | 8. Proportional Valve |
| 4. Lift Solenoid | 9. Check Valve |
| 5. Steering Solenoid | 10. Flow Divider Valve
(on front of block) |

Figure 3-4: Hydraulic Manifold

11. Reconnect the proximity switch.
12. Remove the gauge from the gauge port and reinstall cap.
13. Check for proper operation of the drive system and brake.

3.6 Switch Adjustments

PROXIMITY (Figure 3-5)

The proximity switch is located on the left side of the chassis above the drive wheel. The sealed switch is "U" shaped and is activated by a metal tab welded to the lower boom. When the machine is lowered, and the tab is between the legs of the switch, high speed drive is available. When the machine is raised, the tab exits the switch, and the machine will only drive in creep speed.

Adjustment

1. Adjust proximity switch so machine operates at creep speed when platform is raised above 6 ft. (1.6 m).

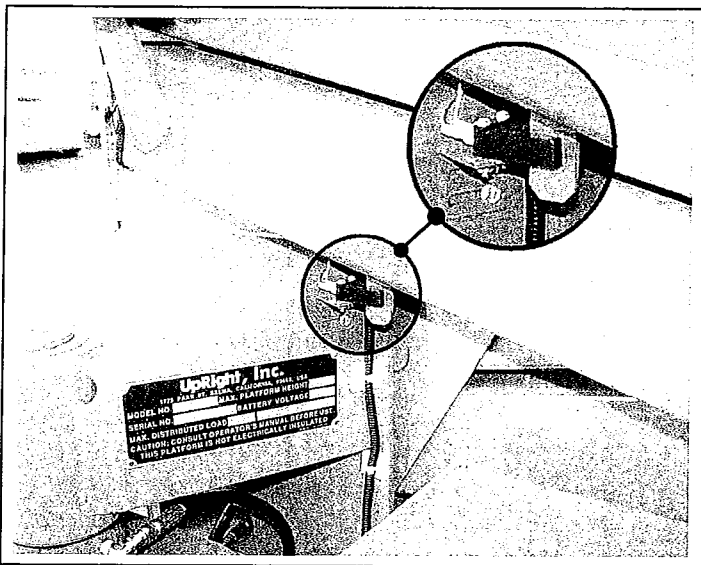

Figure 3-5: Proximity Switch

TILT SENSOR (Figure 3-6)

Introduction

The tilt sensor has three wires; red-power (24 v in), black-ground, white-output (24 v out). To verify the sensor is working properly there is a red LED under the sensor that lights up when the sensor is not level.

Adjustment

1. Place machine on firm level surface $\pm 1/4^\circ$.
2. Use the Inclinator (P/N: 10119-000-00) to ensure front and rear of chassis is level $\pm 1/4^\circ$.
3. Adjust the three leveling screws until the bubble is centered in the inner circle.

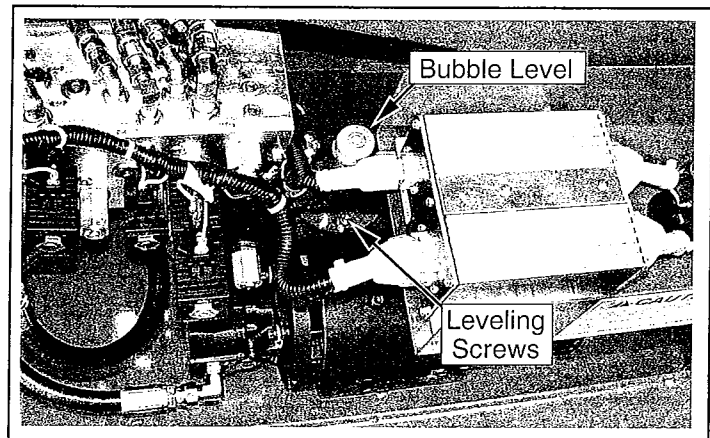

Figure 3-6: Level Sensor Adjustment

RELAY CONTROLLER ADJUSTMENT, TOGGLE SWITCH (Figure 3-7)

The relay control box is located in the lower controls assembly.

Remove the cover plate to gain access to the four potentiometers.

Potentiometer	Adjustment
Acceleration	Clockwise to decrease acceleration Counterclockwise to increase acceleration
Deceleration	Clockwise to decrease deceleration Counterclockwise to increase deceleration
Creep	Clockwise to increase speed Counterclockwise to decrease speed
Start Value	Clockwise to increase start value Counterclockwise to decrease start value

1. Turn both acceleration and deceleration pots fully clockwise. This will make the machine slow to accelerate and decelerate.
2. Adjust the start value to allow the machine to move gradually.
3. Adjust the acceleration pot to 1.2 seconds to full speed.
4. Adjust the deceleration pot to 1 second to full stop.
5. Adjust creep pot for elevated drive speed (20 ft. [6.1 m] in 18 to 22 seconds).

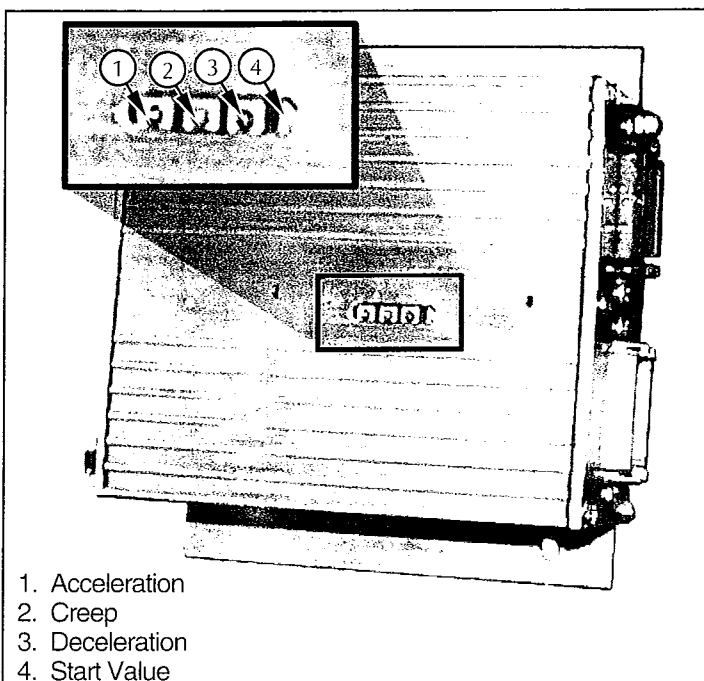
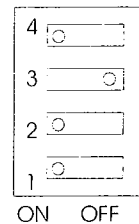

Figure 3-7: Relay Controller Adjustment

DIP SWITCH SETTING, TOGGLE CONTROLLER (FIGURE 8)

Dip 3 is off, all others on.



DIP SWITCH SETTING, PROPORTIONAL CONTROLLER (FIGURE 8)

Dip 3 is on, all others off.

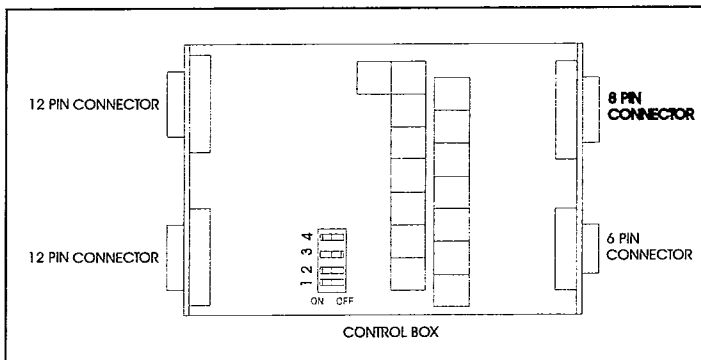
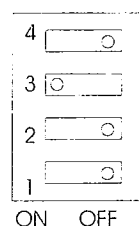

Figure 3-8: Dip Switch Location

Notes:

3.7 Hydraulic Manifold (Figure 3-9)

Though it is not necessary to remove the manifold to perform all maintenance procedures, a determination should be made as to whether or not the manifold should be removed before maintenance procedures begin.

REMOVAL

1. Remove the battery ground cable.
2. Tag and disconnect the solenoid valve leads from the terminal strip.
3. Tag, disconnect, and plug hydraulic hoses.
4. Remove the locknuts, jam nut and bolts that hold the manifold to the mounting bracket.
5. Remove manifold block.

DISASSEMBLY

NOTE: Mark all components as they are removed so as not to confuse their location during assembly. Refer to Figure 3-9 often to aid in disassembly and assembly.

1. Remove coils from solenoid valves.
2. Remove solenoid valves, relief valves and counterbalance valves.
3. Remove fittings, plugs, and springs.

CLEANING AND INSPECTION

1. Wash the manifold in cleaning solvent to remove built up contaminants and then blow out all passages with clean compressed air.
2. Inspect the manifold for cracks, thread damage and scoring where O-rings seal against internal and external surfaces.
3. Wash and dry each component and check for thread damage, torn or cracked O-rings and proper operation.
4. Replace parts and O-rings found unserviceable.

ASSEMBLY

Note: Lubricate all O-rings before installation to prevent damage to O-rings.

1. Install fittings, plugs, and springs.
2. Install counterbalance valves, main relief valve, steering relief valve, and solenoid valves.

Note: torque cartridge valves to 25 ft. lbs. (34 N-m).

3. Install coils on solenoid valves.

Note: torque coil retaining nuts to 4-5 ft. lbs. (5.4-6.8 N-m) maximum.

INSTALLATION

1. Attach manifold assembly to mounting plate with bolts, washers, jam nut and locknuts.

Note: Bolt at the left end of the valve is installed from the bottom and is secured with the jam nut. Secure all ground wires with locknut to this bolt.

2. Connect solenoid leads to terminal strip (as previously tagged).
3. Connect hydraulic hoses. Be certain to tighten hoses to manifold (see *Table 3-2*).
4. Operate each hydraulic function and check for proper function and leaks.
5. Adjust all hydraulic pressures according to instructions in *Section 3.5*.

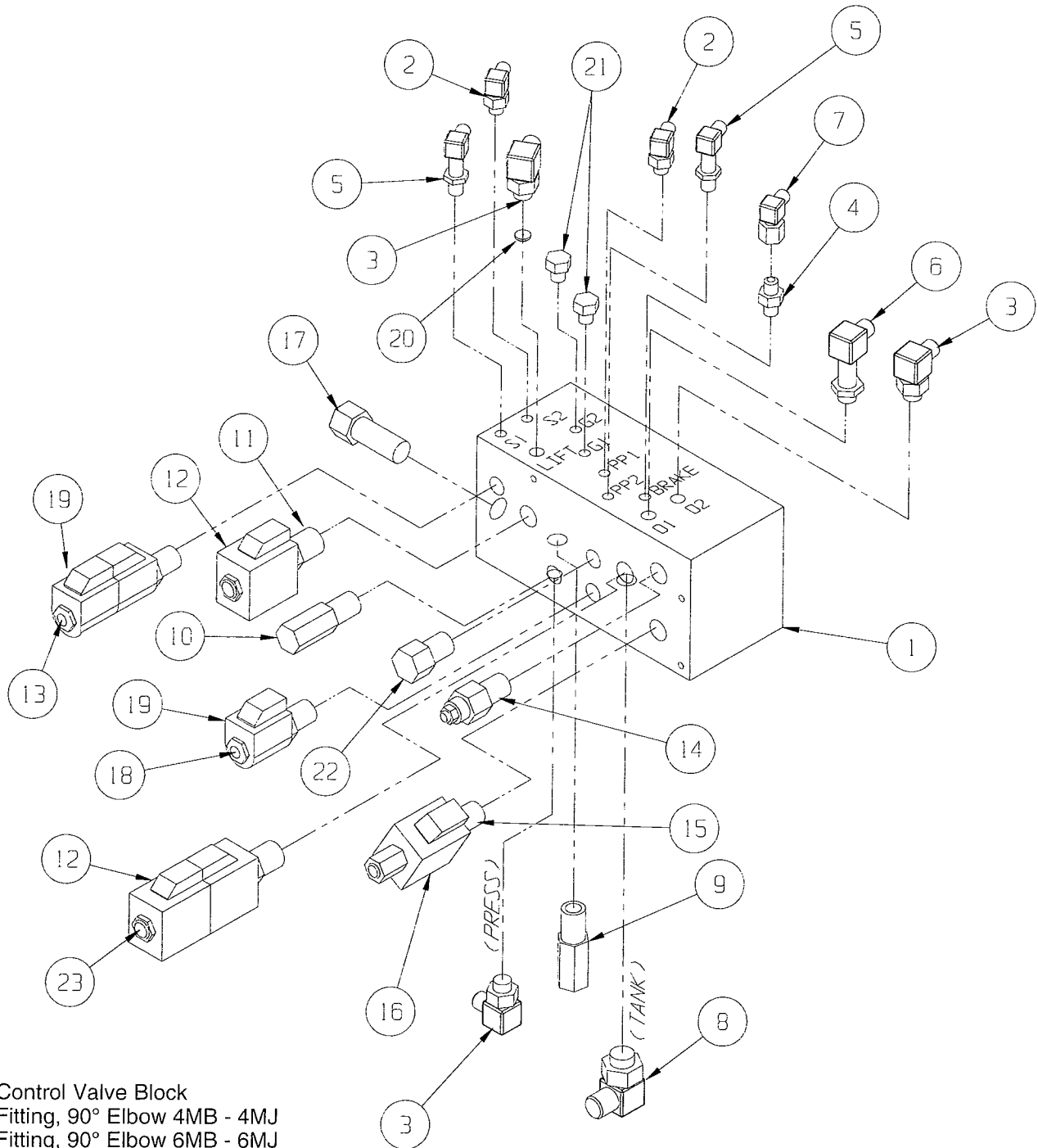

- | | |
|---|--|
| <ul style="list-style-type: none"> 1. Control Valve Block 2. Fitting, 90° Elbow 4MB - 4MJ 3. Fitting, 90° Elbow 6MB - 6MJ 4. Fitting, Straight 4MB - 4MJ 5. Fitting, 90° Elbow 4MB - 4MJ (Extended) 6. Fitting, 90° Elbow 6MB - 6MJ (Extended) 7. Fitting, 90° Elbow 4FJX - 4MJ 8. Fitting, 90° Elbow 8MB - 6MJ 9. Relief Valve, Steering 10. Relief Valve, Main 11. 2 Pos - 4 Way Solenoid W/ Coil (Lift) 12. Coil, 10 Series 20 Volt DC 13. 3 Pos - 4 Way Solenoid W/ Coils (Steering) 14. Counterbalance Valve | <ul style="list-style-type: none"> 15. Proportional Valve W/Coil 16. Coil, 10 Series 24 Volt DC 17. Flow Divider Valve 18. 2 Pos Poppet Valve W/Coil (Pothole Protection) 19. Coil, 8 Series 20 Volt DC 20. Orifice (0.52) Hydro Force 7051-052 21. Fitting Plug 4MB 22. Check Valve 23. 3 Pos - 4 Way Solenoid W/Coils (Drive) |
|---|--|

Figure 3-9: Hydraulic Manifold, Exploded View

3.8 Hydraulic Power Unit (Figure 3-10)

REMOVAL

NOTE: If the hydraulic tank has not been drained, suitable means for plugging the hoses should be provided to prevent excessive fluid loss.

1. Mark, disconnect and plug the hose assemblies.
2. Loosen the capscrews and remove the power unit from the control module.

INSTALLATION

1. Place the power unit into the control module. Torque the mounting screws to 30 ft.lbs. (41 N-m).
2. Unplug and reconnect the hydraulic hoses.
3. Check the oil level in the hydraulic tank before operating the work platform.

3.9 Hydraulic Drive Motors and Hubs (Figure 3-11)

REMOVAL

1. Park the work platform on firm level ground then block the wheels to prevent the work platform from rolling.
2. Loosen the wheel lug bolts on the front corner to be raised.
3. Use a 1.5 ton capacity jack to raise the desired rear corner. Position blocks under the raised corner to prevent the work platform from falling if the jack fails.
4. Remove the wheel lug bolts and wheel.
5. Remove the cotter pin, slotted nut, and hub. If necessary use a wheel puller to remove hub.

NOTE: Before disconnecting hoses, thoroughly clean off all outside dirt around fittings. (After disconnecting hoses and before removing from vehicle, IMMEDIATELY plug port holes.)

6. Tag, disconnect and plug the hose assemblies to prevent foreign material from entering.
7. Remove the locknuts, capscrews and drive motor from the motor mount.

INSTALLATION

1. Referring to Figure 3-14, position the drive motor in the motor mount and secure with capscrews and locknuts. Torque to 75 ft.lbs. (102 N-m).
2. Remove the plugs from the hose assemblies and connect to the drive motor.
3. Install the hub and slotted nut. Torque the locknut to 140 to 160 ft. lbs. (190-217 N-m). Install a new cotter pin, **DO NOT** back-off the nut to install the cotter pin.
4. Install the wheel with lug bolts onto the hub. Torque to 80 ft. lbs. (108 N-m).
5. Remove blocks, lower the jack and remove. Operate the drive system and check for leaks.
6. Drive machine for 20 minutes and retorque wheel lug bolts and check for leaks.

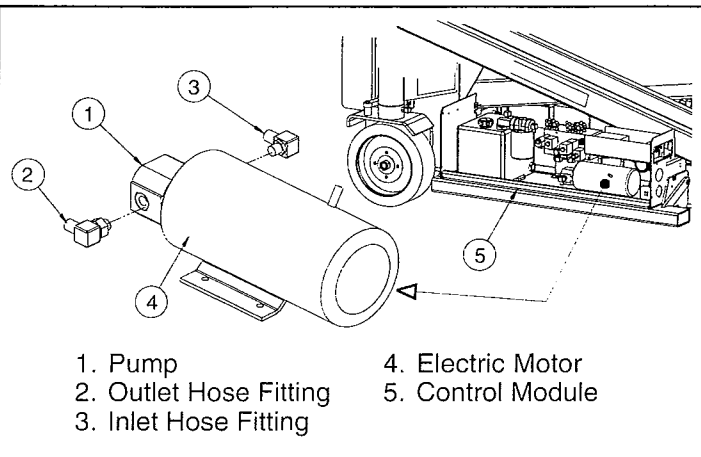

Figure 3-10: Hydraulic Power Unit

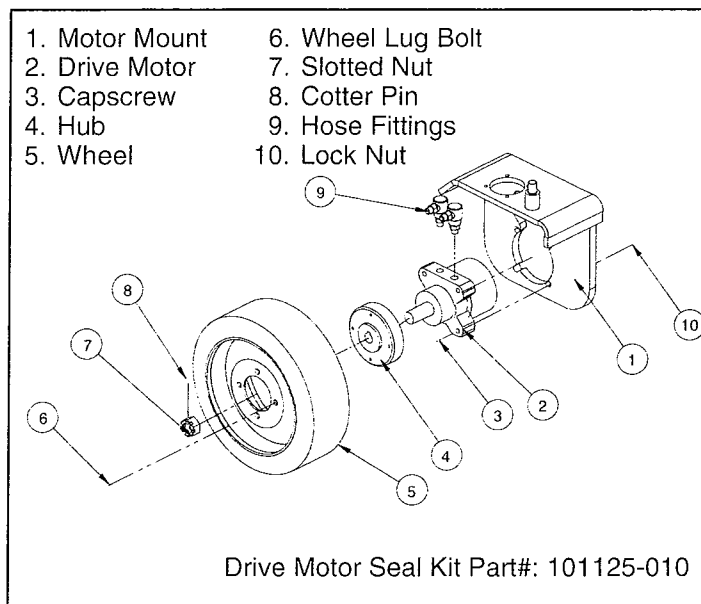

Figure 3-11: Hydraulic Drive Motor

3.10 Wheel Bearings (Figure 3-12)

REMOVAL

1. Loosen the wheel lug nuts then, using a 1.5 ton capacity jack, raise the work platform until the tire to be worked on is off the ground.
2. Install support blocks to prevent the work platform from falling if the jack fails.
3. Remove the wheel lug nuts and the wheel.
4. Remove the dust cap.
5. Remove the cotter pin.
6. Remove the hub nut and washer.
7. Slide the entire hub assembly from the spindle and place on clean surface.
8. Remove the outside bearing cone and place on clean surface.
9. Remove the grease seal and the inside bearing cone.
Examine the bearing cups. If they are smooth, shiny and free of pits or any surface irregularities, **DO NOT** remove them.
10. If the cups need replacement, remove them by tapping around the circumference of the inside surface of the cups from the opposite side using a long drift.

INSTALLATION

1. Position the replacement bearing cup over the opening in the hub assembly then position the worn cup over the replacement so that the bearing surfaces face each other. Use the old bearing cone as a drift to work the replacement into position by tapping evenly around the circumference.
2. Apply a liberal coating of multipurpose grease to the bearing surface of each cup.
3. Pack the inside bearing cone with multipurpose grease and position it within the rear bearing cup in the hub assembly. Install the new grease seal.
4. Apply a thin coating of multipurpose grease to the spindle to protect the grease seal then slide the hub assembly onto the spindle.
5. Pack the outside bearing cone with multipurpose grease and slide it onto the spindle until it seats in the outer bearing cup.
6. Install the washer and hub nut. Tighten the hub nut, while rotating the assembly, until the hub drags then back the nut to the first slot that aligns with the cotter pin hole in the spindle.
7. Install a new cotter pin and bend the end up over the hub nut and the spindle.
8. Install the cap and wheel/tire assembly. Torque the lug nuts to 80 ft. lbs. (108 N-m).
9. Remove blocks and lower work platform to the ground.
10. Drive machine for 20 minutes and retorque wheel lug nuts and check for leaks.

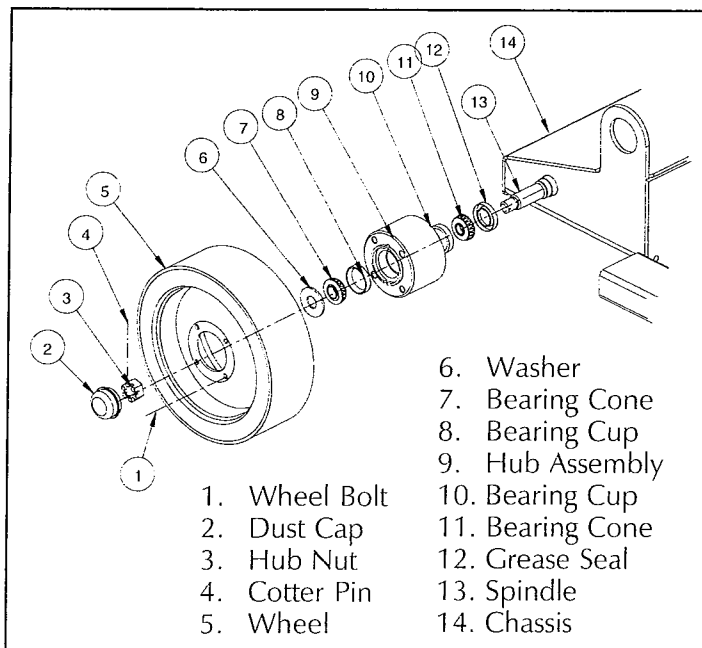

Figure 3-12: Wheel Bearings

3.11 Brake Cylinder (Figure 3-13)

REMOVAL

1. Block the wheels to prevent the work platform from rolling.
2. Loosen the wheel lug nuts then, using a 1.5 ton capacity jack, raise the work platform until the tire to be worked on is off the ground.
3. Install support blocks to prevent the work platform from falling if the jack fails.
4. Remove the wheel lug nuts and the wheel.
5. Disconnect the hose assemblies from the drive motor and brake cylinder and cap the openings to prevent foreign material from entering.

NOTE: The motor mount assembly is heavy. The use of a support device is recommended.

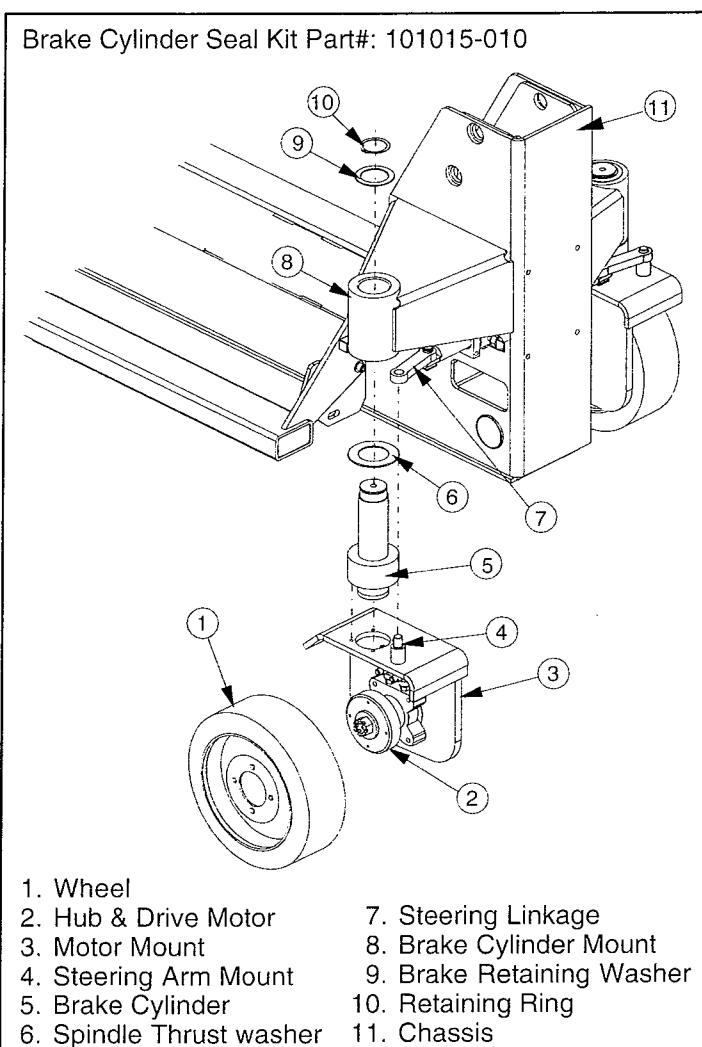

Figure 3-13: Brake Cylinder

6. Remove the retaining ring and brake retaining washer from the top of the brake cylinder.
7. Slowly lower the motor mount assembly and guide the brake cylinder out of the brake cylinder mount. The spindle thrust washer will come off with the brake cylinder.
8. Lay the motor mount assembly on its side to access the brake cylinder mounting screws.
9. Remove the mounting screws and remove the cylinder from the motor mount.

INSTALLATION

1. Install the brake cylinder assembly onto the motor mount assembly. Apply Loctite 242 and torque the cap screws to 30 ft.lbs. (41 N-m).
2. Place the spindle thrust washer onto the spindle of the brake cylinder assembly.
3. Raise the motor mount and brake cylinder assembly into the brake cylinder mount.
4. When the brake cylinder is almost fully inserted into the brake cylinder mount, align the steering arm with the steering arm spindle.
5. Raise the unit until it is fully inserted into the brake cylinder mount.
7. Install the brake cylinder retaining washer and secure with snap ring.
8. Connect the hose assemblies.
9. Install the wheel with lug bolts onto the hub. Torque to 80 ft. lbs. (108 N-m).
10. Remove blocks, lower the jack and remove. Operate the brakes and drive system and check for leaks.
11. Drive machine for 20 minutes and retorque wheel lug bolts and check for leaks.
12. Operate the drive circuit and check that the shaft retracts and clears the wheel. Check for leaks.

3.12 Steering Cylinder (Figure 3-14)

REMOVAL

1. Mark and disconnect the hose assemblies from the fittings and immediately cap the openings to prevent foreign material from entering.
2. Remove the retaining rings and the steering pins from both ends of the steering cylinder.
3. Remove the steering arms from both ends of the steering cylinder.
4. Remove the locknuts and capscrews from the steering bearing flanges.
5. Slide the steering cylinder out of the chassis.

DISASSEMBLY

1. Unscrew heads from cylinder.
2. Pull rod from cylinder.
3. Remove seal kit components from head and piston.

CLEANING AND INSPECTION

1. Wash all the metal parts in cleaning solvent and blow dry with filtered compressed air.

2. Inspect all the threaded components for stripped or damaged threads.
3. Check the inside surface of the cylinder barrel for scoring or excessive wear.
4. Check the piston and headcap for scoring or excessive wear.
5. Inspect the surface of the shaft for scoring or excessive wear.

ASSEMBLY AND INSTALLATION (FIGURE 3-15)

1. Lubricate and install new rod seal, rod wiper, backup ring and o-ring on the headcaps.
2. Lubricate and install the seal and wear ring in the piston.
3. Lubricate the piston seal with clean hydraulic fluid and install the rod assembly in the cylinder barrel.
4. Screw headcaps into cylinder barrel.

INSTALLATION

1. Installation is reverse of removal.
2. Cycle steering cylinder several times to remove air from the system.
3. Check cylinder for proper operation and check all connections for leaks.

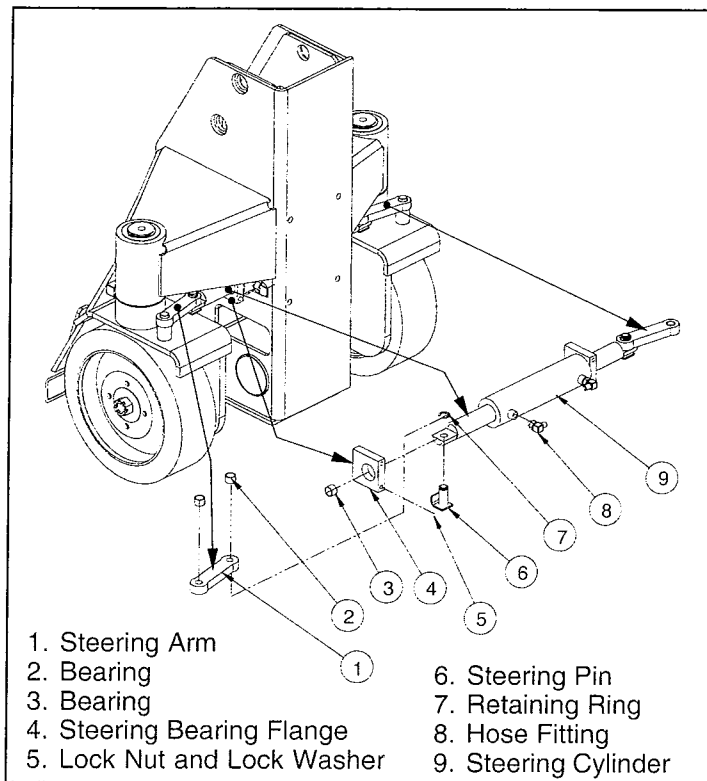

Figure 3-14: Steering Cylinder Installation

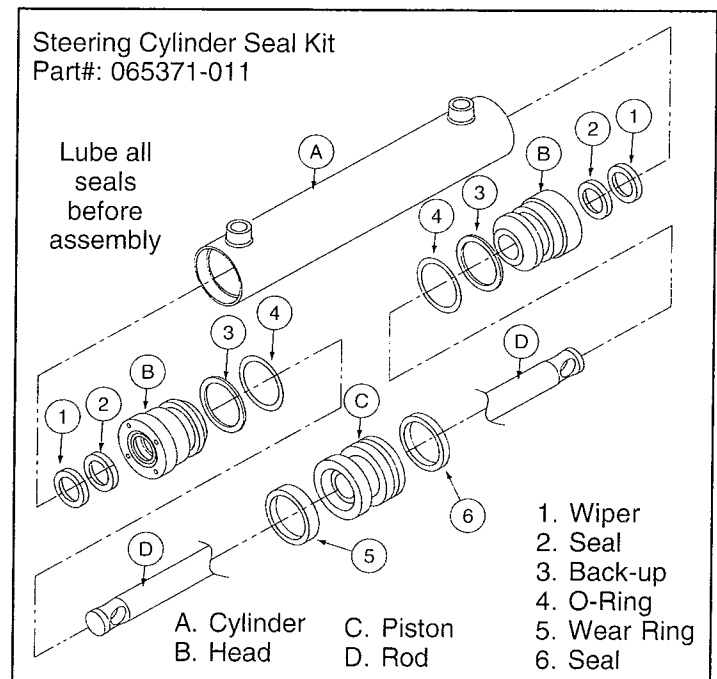

Figure 3-15: Steering Cylinder Assembly

3.13 Lift Cylinder (Figure 3-17)

REMOVAL

1. Block Elevating Assembly (Section 3.2).
2. Provide a suitable container to catch the hydraulic fluid, then disconnect the hydraulic hoses. Immediately plug hoses to prevent foreign material from entering.
3. Remove the set screw from end of cylinder rod.
4. Place a 2 ft. (61 cm) long plank, at least 1 in. (25 mm) thick, across the top of the modules.
5. Support rod end of cylinder and remove rod end cylinder pin and let cylinder down to rest on the plank.
6. Support the lower tension links.
7. Attach a suitable hoisting device and sling to the cylinder.
8. Support the cylinder so the barrel end cylinder pin can be removed, then remove the cylinder from the machine with the hoisting device.
9. Move cylinder to a prepared work area.

DISASSEMBLY (FIGURE 3-17)

1. Remove set screw which secures cylinder head.
2. Unscrew head from cylinder.
3. Pull rod assembly out of cylinder.
4. Remove seal kit components from head and piston.
5. Check end bearing for wear. Remove and replace if necessary.

CLEANING AND INSPECTION

1. Clean all metal parts in solvent and blow dry with filtered compressed air.
2. Check all threaded parts for stripped or damaged threads.
3. Check the bearing surfaces inside of the headcap, outer edge surface of the piston, inside of the cylinder barrel and the shaft for signs of scoring or excessive wear.
4. Replace any parts found unserviceable.

REASSEMBLY

1. Lubricate and install wear rings and seal on piston.
2. Lubricate and install static seal rod seal and rod wiper on head.
3. Carefully slide rod assembly into cylinder.
4. Screw head into cylinder and secure using set screw.

INSTALLATION (Figure 3-16)

Note: before installing Lift Cylinder check cylinder pins and bearings for wear and replace if necessary.

1. Place two 2 ft. (61 cm) long planks, at least 1 in. (25 mm) thick, across the top of the modules.
2. Place the lift cylinder on the planks across the modules.
3. Lift the lower tension links into position.
4. Lift the barrel end of the cylinder into place and push the cylinder pin in until approximately 1½ in. (38 mm) is still exposed.

Note: take care in aligning the holes so that the pin can be pushed in by hand. If holes are not properly aligned and the pin is forced in, the bearings will be damaged.

4. Install anti-rotation pin into cylinder pin aligning with hole in the lower tension link and push the cylinder pin completely in. Secure with set screw.
5. Lift rod end of cylinder into place and insert pin. Install anti-rotation pin into rod-end pin aligning with hole in the upper boom and push the cylinder pin completely in. Secure with set screw.
5. Cycle lift cylinder several
6. Test with weight at rated platform load to check system operation.

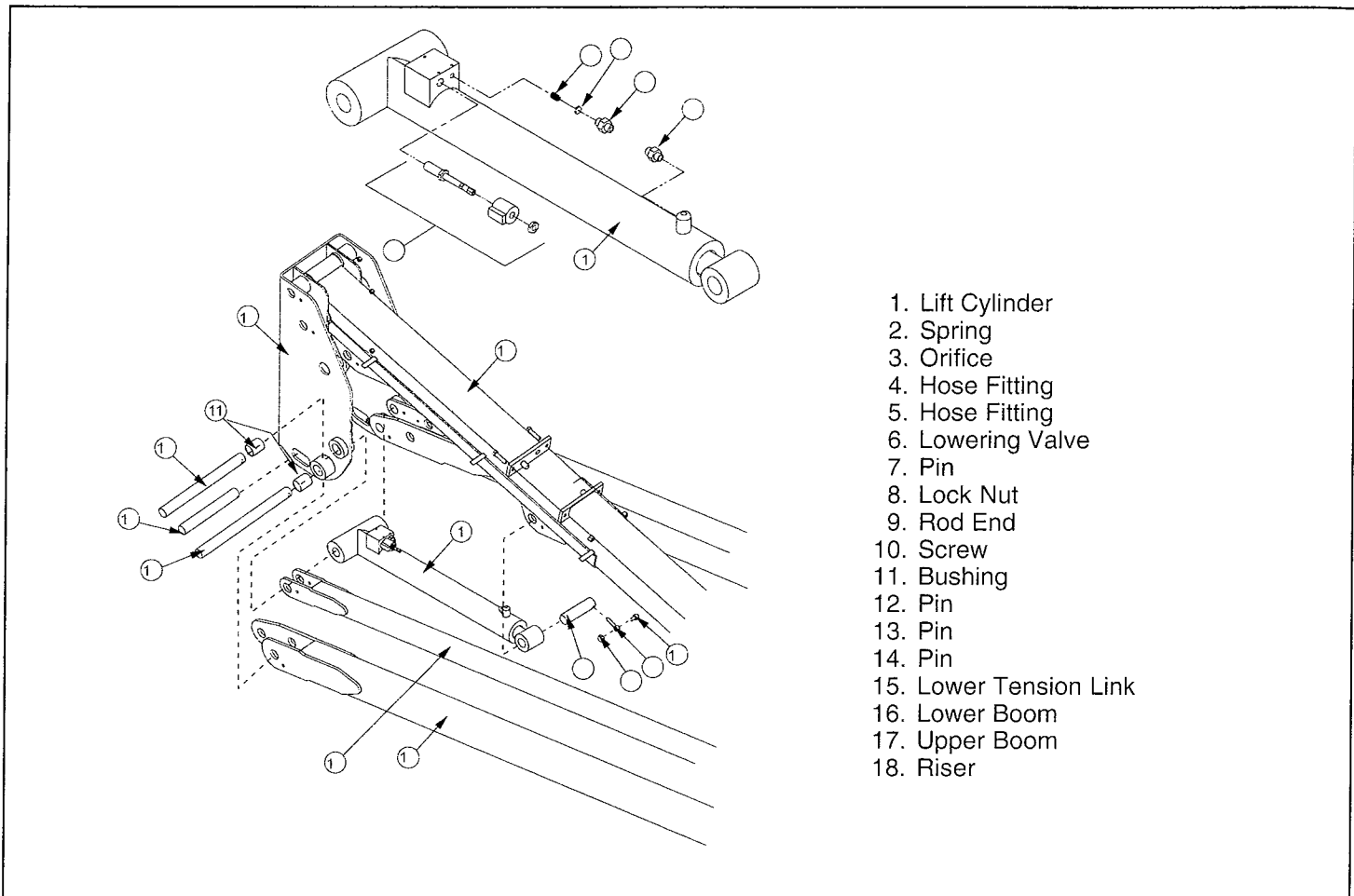

1. Lift Cylinder
2. Spring
3. Orifice
4. Hose Fitting
5. Hose Fitting
6. Lowering Valve
7. Pin
8. Lock Nut
9. Rod End
10. Screw
11. Bushing
12. Pin
13. Pin
14. Pin
15. Lower Tension Link
16. Lower Boom
17. Upper Boom
18. Riser

Figure 3-16: Lift Cylinder Installation

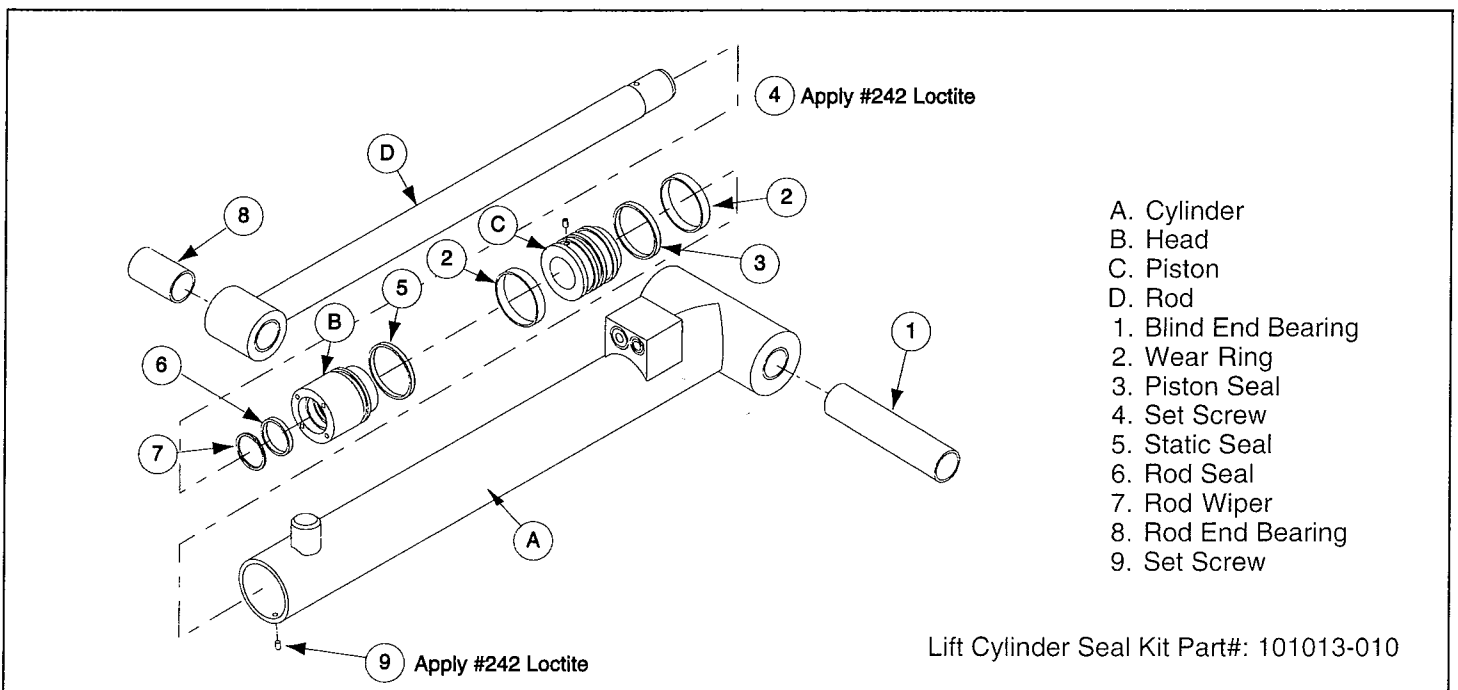

- A. Cylinder
- B. Head
- C. Piston
- D. Rod
1. Blind End Bearing
2. Wear Ring
3. Piston Seal
4. Set Screw
5. Static Seal
6. Rod Seal
7. Rod Wiper
8. Rod End Bearing
9. Set Screw

Lift Cylinder Seal Kit Part#: 101013-010

Figure 3-17: Lift Cylinder Assembly

3.14 Pot Hole Cylinder (Figure 3-18)

REMOVAL

1. Mark and disconnect the hose assemblies from the fittings and immediately cap the openings to prevent foreign material from entering.
2. Support the pot hole tube weldments on both sides.
3. Remove the cotter pin and the pot hole pine weldment from both ends of the pothole cylinder.
4. Lift the cylinder out of the unit and move to a prepared work area.

DISASSEMBLY (FIGURE 3-19)

1. Unscrew head from cylinder.
2. Pull rod assembly from cylinder.
3. Remove seal kit components from head and piston.

CLEANING AND INSPECTION

1. Wash all the metal parts in cleaning solvent and blow dry with filtered compressed air.
2. Inspect all the threaded components for stripped or damaged threads.
3. Check the inside surface of the cylinder barrel for scoring or excessive wear.
4. Check the piston and headcap for scoring or excessive wear.

5. Inspect the surface of the shaft for scoring or excessive wear.

ASSEMBLY

1. Lubricate and install seal on piston.
2. Lubricate and install rod wiper, rod seal and static seal onto head.
3. Carefully push rod assembly into cylinder.
4. Screw head into cylinder.

INSTALLATION

1. Installation is reverse of removal.
2. Cycle cylinder several times to remove air from system.
3. Check all connections for leaks.

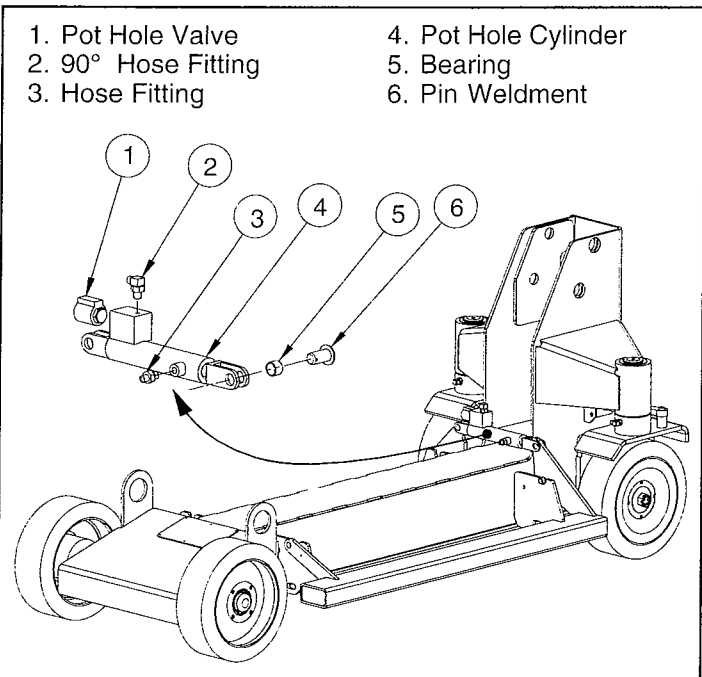

Figure 3-18: Pothole Cylinder Installation

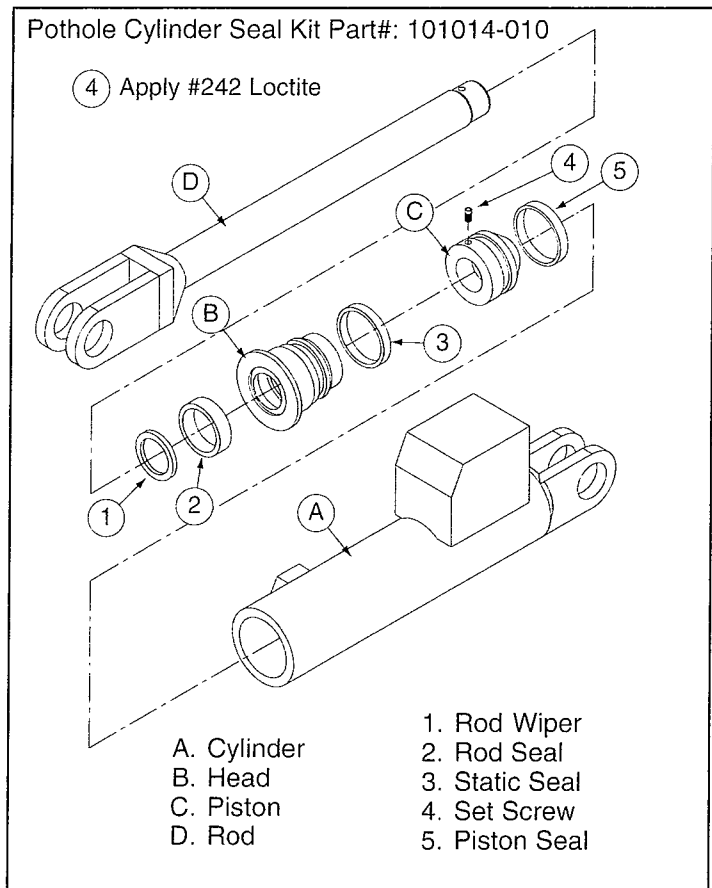

Figure 3-19: Pothole Cylinder Assembly

POTHOLE PROTECTION SYSTEM ADJUSTMENT

1. Place machine on firm level surface $\pm 1/4^\circ$.
2. Raise the machine for access to level sensor.
3. Center level sensor bubble by turning adjustment screws on level sensor (Fig. 3-6).
4. Set proximity switch to de-activate at 6 ft. (1.6 m) platform height (Fig. 3-5).
5. Check that pothole protectors are fully deployed before limit switch de-activates when lifting.
6. Check pothole protection system operation.
 - a.) Machine should not elevate above 6 ft. (1.6 m) while on a 2° slope.
 - b.) Machine should have low speed drive when limit switch is de-activated and machine is level.
 - c.) Machine should have high speed drive when limit switch is activated.
 - d.) Tilt alarm should sound when platform is elevated above 6 ft. (1.6 m) and machine is off level by 2° .
7. Adjust stops so that it allows $3/4^\circ$ ($\pm 1/16^\circ$) ground clearance.

3.15 Adjustable Compression Tube Tube (Figure 3-20)

Support platform using an overhead hoist.

Add shims as required to level platform $\pm .75^\circ$ (1 1/4").

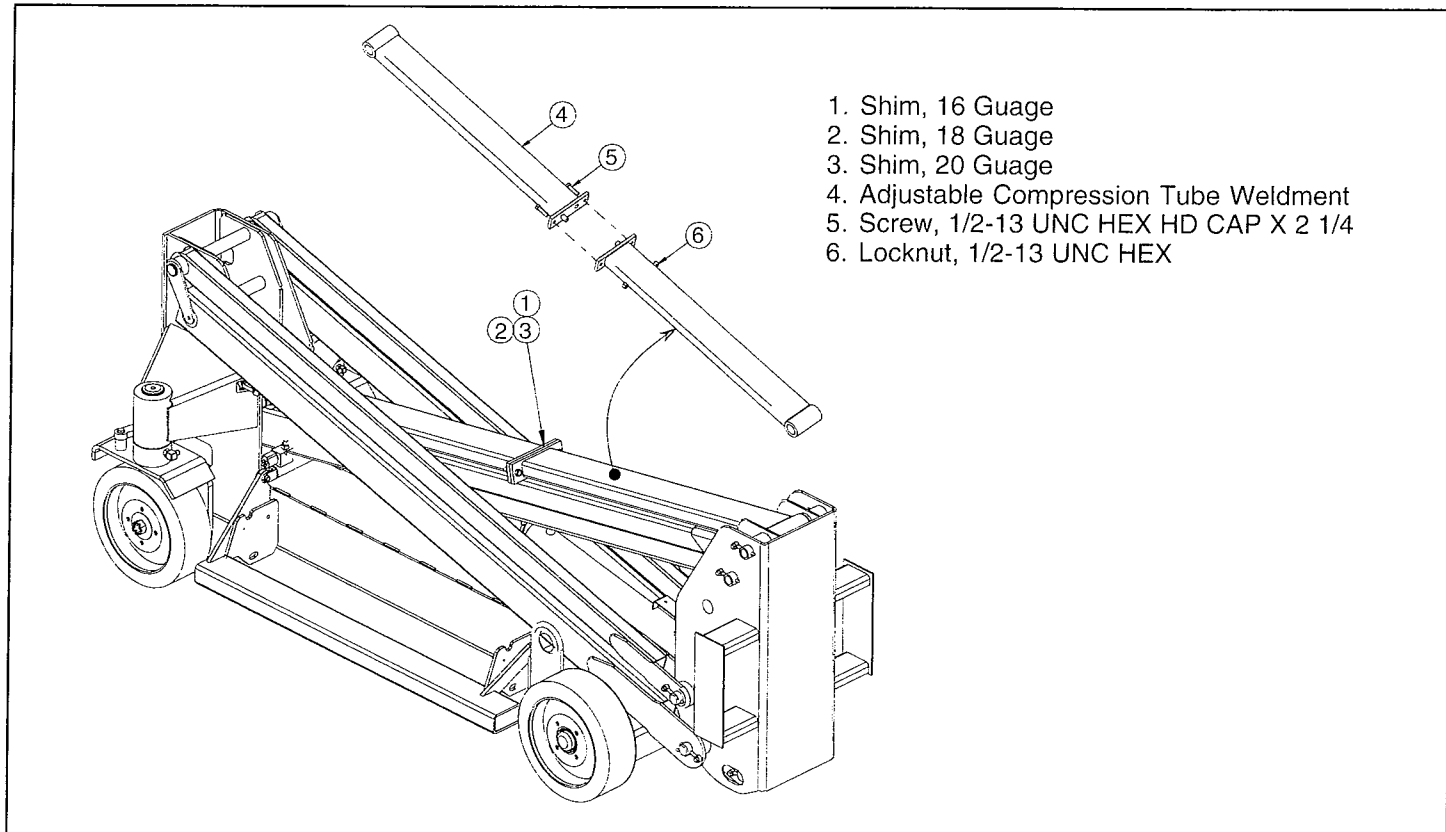

Figure 3-20: Compression Tube Assembly

3.16 Electric Motor (Figure 3-21)

TROUBLESHOOTING

1. Read the nameplate to become familiar with the motor, especially the rated voltage.
2. Try to turn the shaft by hand. Keep motor leads separated while doing this. If the shaft turns freely go to step 3. If the shaft won't turn, proceed to step 2A.
- 2A. The shaft could be tight for a number of reasons, this check is to determine if the tightness is of a temporary nature only. Obtain power to produce the nameplate voltage. **Do Not make a permanent connection.** First touch the motor leads quickly to the power supply just long enough to observe if the shaft runs. If it does turn, then hold the motor leads on the power supply for a longer time. If the motor sounds normal, go to step 3. If the motor sounds noisy, it should be taken apart as described in the disassembly section.
3. If the motor turned freely, connect an ammeter in the circuit as shown in Figure 3-21A. With rated voltage applied and the shaft running free, the ammeter should read less than 20% of the nameplate full load current. If the motor meets the above conditions then it can be assumed the original problem is external to the motor.

DISASSEMBLY

1. Remove thru bolts.
2. Remove pulley end cover.
3. Pull the armature out of the assembly in one swift motion.
4. Remove commutator end cover.

NOTE: Do not place the stator ring in any mechanical holding device during the disassembly or assembly operation. Permanent distortion or other damage will result.

INSPECTION

Once the motor has been disassembled, go through the following check list steps to determine where the problem lies.

1. Bearings should spin smoothly and easily and have ample lubrication and be free of corrosion.
2. Armature should be checked for grounds and shorted turns. Refinish commutator surface if pitted or excessively worn.

3. Brushes should be checked for wear and to ensure that they are free in the brush holders.

NOTE: Observe how brushes are assembled in brush holders and position of brush lead. New brushes must be installed in same manner. Brushes should be removed as follows:

- Remove brush spring clip from its mounting on brush assembly.
 - Lift brush assembly from brush holder.
 - Disconnect brush assembly lead.
 - New brush assembly to be installed by reversing above procedure.
4. Inspect wire harness and all connections for signs of damage due to overheating.
 5. Check stator to see it is securely mounted.

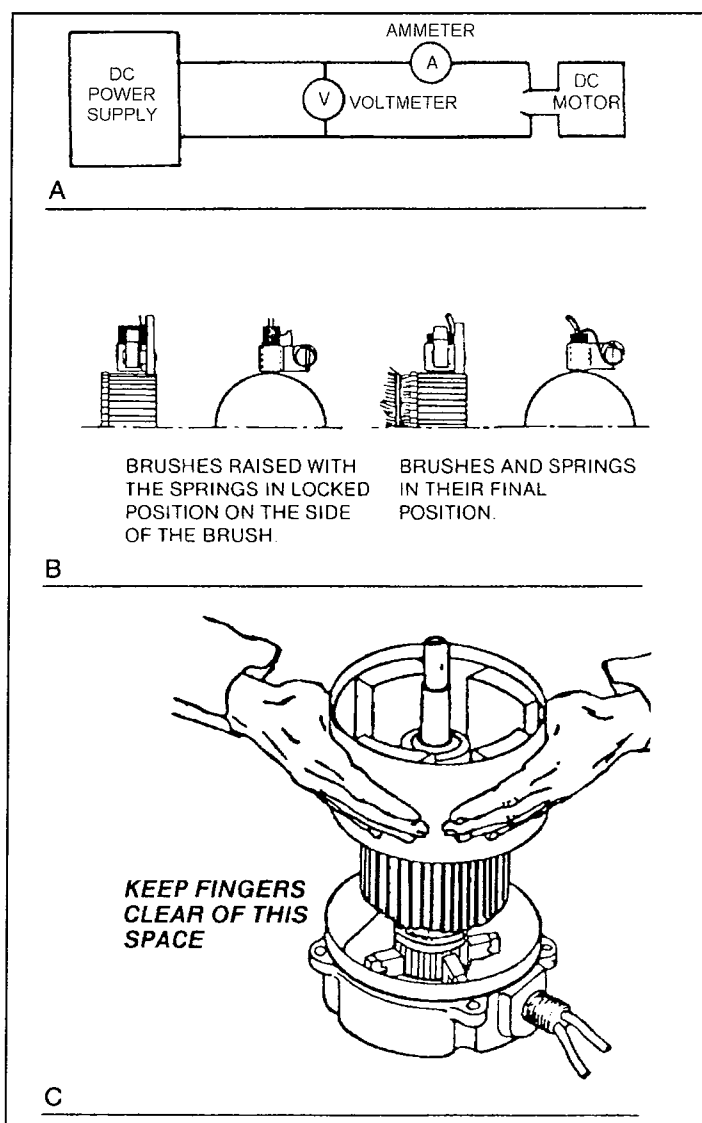

Figure 3-21: Electric Motor Service

REASSEMBLY

1. Install new brushes and be sure they are free in the holder. Install brush with the lead wires positioned as when received. Raise all brushes to the locked position. (See Figure 3-21B and step 3 in the Inspection section).
2. Place commutator cover on a work bench with brush assembly facing upward.
3. Place the bearing spring into the bearing bore.
4. Take a complete armature assembly, including bearings, and insert commutator end bearing into the bearing bore.
Note: Do not reuse bearings which have been removed from armature shaft. Keep assembly in a vertical position. Use extreme care not to damage armature with bearing pullers. New bearings should be installed by pressing inner race of bearing onto proper position on armature shaft.
5. Set the brushes to final position as shown in Figure 3-21B.
6. Place the complete stator down over the vertical armature, and into position on the commutator cover.
7. The stator assembly must be placed in a definite relationship with the commutator covers in order to obtain a neutral brush setting. There is a match-mark on both items. **These two marks must line up exactly. Rotate until they do.**
8. Assemble the pulley end cover in the proper relationship. Insert mounting bolts and tighten alternately to ensure a good mechanical alignment.
9. Spin the shaft by hand to see if it is free. Be sure motor leads (if used) are not touching together. If the leads are touching, a generator action will give the effect of friction in the motor. A no-load test can now be performed. At rated voltage, observe the no-load current. It should be less than 20% of the nameplate full load current. Anything higher indicates:
 - Brushes are not on neutral setting (check match-marks for exact alignment).
 - Faulty armature.

3.17 Torque Specifications (Table 3-2)

FASTENERS

Use the following values to torque fasteners used on UpRight Work Platforms unless a specific torque value is called out for the part being installed.

Table 3-2: Bolt Torque

THREAD SIZE <small>American National Std.-UNC (course)</small>	WIDTH ACROSS FLATS	TORQUE VALUE		
		GRADE 5		GRADE 8
		<small>For items which must be removed frequently</small>	<small>For items infrequently removed and subject to high vibration</small>	<small>For extreme high vibration</small>
1/4	7/16	75 In/Lbs (102 Nm)	110 In/Lbs (12 Nm)	-
5/16	1/2	125 In/Lbs (14 Nm)	190 In/Lbs (21 Nm)	-
3/8	9/16	20 Ft/Lbs (27 Nm)	30 Ft/Lbs (41 Nm)	-
1/2	3/4	50 Ft/Lbs (68 Nm)	75 Ft/Lbs (102 Nm)	100 Ft/Lbs (136 Nm)
5/8	1 5/16	100 Ft/Lbs (136 Nm)	150 Ft/Lbs (203 Nm)	190 Ft/Lbs (258 Nm)
3/4	1 1/8	175 Ft/Lbs (237 Nm)	250 Ft/Lbs (339 Nm)	350 Ft/Lbs (475 Nm)
1	1 1/2	400 Ft/Lbs (542 Nm)	600 Ft/Lbs (813 Nm)	900 Ft/Lbs (1220 Nm)

HYDRAULIC COMPONENTS

Use the following values to torque hydraulic components used on UpRight Work Platforms.

Note: Always lubricate threads with clean hydraulic oil prior to installation.



Table 3-3: Hydraulic Component Torque

TYPE: SAE PART SERIES	CARTRIDGE POPPET TYPE		CARTRIDGE SPOOL TYPE		FITTINGS		HOSES	
	Ft/Lbs	Nm	Ft/Lbs	Nm	Ft/Lbs	Nm	In/Lbs	Nm
#4	N/A	N/A	N/A	N/A	N/A	N/A	135-145	15-16
#6	N/A	N/A	N/A	N/A	10-20	14-27	215-245	24-28
#8	25-30	34-41	25-30	34-41	25-30	34-41	430-470	49-53
#10	35-40	47-54	35-40	47-54	35-40	47-54	680-750	77-85
#12	85-90	115-122	85-90	115-122	85-90	115-122	950-1050	107-131
#16	130-140	176-190	130-140	176-190	130-140	176-190	1300-1368	147-155

Coil nuts: 30 IN/Lbs (3 Nm)

4.0 Introduction

Table 4-1 & 4-2 contain troubleshooting Truth Tables for the electronic control system. Table 4-3 contains a troubleshooting Truth Table for the hydraulic system.

 WARNING 
<p>When troubleshooting, ensure that the work platform is resting on a firm, level surface.</p> <p>When performing any service which requires the Platform to be raised, ensure that all four (4) outriggers are properly installed.</p> <p>Unplug the machine or disconnect the battery when replacing or testing the continuity of any electrical component.</p>

GENERAL PROCEDURE

Thoroughly study hydraulic and electronic schematics. Check for loose connections and short circuits. Check/repair/replace each component in the Truth Table which is listed under each machine function which does not operate properly.

Troubleshooting

Table 4-1: Electric Truth Table, Standard Toggle Controls

COMPONENT		Function	Upper Control Functions	Lower Control Functions	Lift	Drive Forward	Creep	Steer Left	Steer Right	Battery Charge	Down	Drive Reverse	Pothole Extend	Pothole Retract	Brakes
ALM	ALARM										X				
BAT	BATTERIES		X	X	X	X	X	X	X	X	X	X	X	X	X
CB	CIRCUIT BREAKER (15Amp)		X	X	X	X	X	X	X		X	X	X	X	X
CHG	BATTERY CHARGER									X					
CONT	RELAY CONTROLLER		X	X	X	X	X	X	X		X	X	X	X	X
CR1	MOTOR START RELAY		X	X	X	X	X	X	X			X	X	X	X
CR1	RELAY CONTACT (N O)		X	X	X	X	X	X	X			X	X	X	X
CR1	RELAY CONTACT (N C)									X					
FU1	FUSE (175Amp)		X	X	X	X	X	X	X		X	X	X	X	X
MOT	MOTOR		X	X	X	X	X	X	X			X	X	X	X
MTR	HOUR METER (Optional)				X	X	X	X	X			X			
S2	FORWARD / UP REVERSE / DOWN				X	X					X	X			
S4	LIFT/LO DRIVE LIFT HI DRIVE SELECTOR		X		X	X	X	X	X		X	X			
S5	PLATFORM EMERGENCY STOP		X	X	X	X	X	X	X		X	X			X
S6	STEER SWITCH							X	X						
S7	FOOT SWITCH		X		X	X	X	X	X		X	X			
S8	UP/DOWN SWITCH			X	X						X				
S9	KEY SWITCH		X	X	X	X	X	X	X		X	X	X	X	X
S10	CHASSIS EMERGENCY STOP		X	X	X	X	X	X	X		X	X	X	X	X
S11	PROXIMITY SWITCH						X							X	
SNSR	TILT SENSOR		X	X	X	X	X	X	X			X			
SOL1	PROPORTIONAL SOLENOID		X			X	X					X			
SOL2	FORWARD SOLENOID					X									
SOL3	REVERSE SOLENOID											X			
SOL4	LIFT SOLENOID				X								X		
SOL5	POTHOLE EXTEND SOLENOID												X		
SOL6	STEER LEFT SOLENOID							X							
SOL7	STEER RIGHT SOLENOID								X						
SOL8	DOWN SOLENOID										X				
SOL9	POTHOLE RETRACT SOLENOID													X	

Troubleshooting

Table 4-2: Electric Truth Table, Optional Proportional Controls

COMPONENT		Function	Upper Control Functions	Lower Control Functions	Lift	Drive Forward	Creep	Steer Left	Steer Right	Battery Charge	Down	Drive Reverse	Pothole Extend	Pothole Retract	Brakes
ALM	ALARM										X				
BAT	BATTERIES		X	X	X	X	X	X	X	X	X	X	X	X	X
CB	CIRCUIT BREAKER (15Amp)		X	X	X	X	X	X	X		X	X	X	X	X
CHG	BATTERY CHARGER									X					
CONT1	JOYSTICK CONTROLLER		X		X	X	X	X	X		X	X			
CONT2	RELAY CONTROLLER		X	X	X	X	X	X	X		X	X	X	X	X
CR1	MOTOR START RELAY		X	X	X	X	X	X	X			X	X	X	X
CR1	RELAY CONTACT (N O)		X	X	X	X	X	X	X			X	X	X	X
CR1	RELAY CONTACT (N C)									X					
FU1	FUSE (175Amp)		X	X	X	X	X	X	X		X	X	X	X	X
JOYS	JOYSTICK		X		X	X	X	X	X		X	X			
MOT	MOTOR		X	X	X	X	X	X	X			X	X	X	X
MTR	HOUR METER (Optional)				X	X	X	X	X			X			
S1	POWER TO JOYSTICK		X		X	X	X					X			
S2	DOWN / REVERSE										X	X			
S3	LIFT / FORWARD				X	X									
S4	LIFT/DRIVE SELECTOR		X		X	X	X	X	X		X	X			
S5	PLATFORM EMERGENCY STOP		X	X	X	X	X	X	X		X	X			X
S6	ROCKER SWITCH						X	X							
S7	INTERLOCK SWITCH		X		X	X	X	X	X		X	X			
S8	UP/DOWN SWITCH			X	X						X				
S9	KEY SWITCH		X	X	X	X	X	X	X		X	X	X	X	X
S10	CHASSIS EMERGENCY STOP		X	X	X	X	X	X	X		X	X	X	X	X
S11	PROXIMITY SWITCH						X							X	
SNSR	TILT SENSOR		X	X	X	X	X	X	X			X			
SOL1	PROPORTIONAL SOLENOID		X			X	X					X			
SOL2	FORWARD SOLENOID					X									
SOL3	REVERSE SOLENOID											X			
SOL4	LIFT SOLENOID				X								X		
SOL5	POTHOLE EXTEND SOLENOID												X		
SOL6	STEER LEFT SOLENOID						X								
SOL7	STEER RIGHT SOLENOID							X							
SOL8	DOWN SOLENOID										X				
SOL9	POTHOLE RETRACT SOLENOID													X	

Table 4-3: Hydraulic Truth Table

COMPONENT		Function									
		Lift	Drive Forward	Creep	Steer Left	Steer Right	Down	Drive Reverse	Pothole Extend	Pothole Retract	Brakes
CV1	CHECK VALVE								X	X	
CYL1	STEER CYLINDER				X	X					
CYL2	BRAKE CYLINDER		X	X				X			X
CYL3	LIFT CYLINDER	X					X				
CYL4	POTHOLE CYLINDER								X	X	
FD1	FLOW DIVIDER	X	X	X	X	X		X	X	X	X
FL1	RETURN FILTER	X	X	X	X	X	X	X	X	X	
FL2	TANK SCREEN	X	X	X	X	X		X	X	X	
MOT2	RIGHT DRIVE MOTOR		X	X				X			
MOT1	LEFT DRIVE MOTOR		X	X				X			
ORF1	DOWN ORIFICE						X				
ORF2	LIFT ORIFICE	X									
PMP	PUMP	X	X	X	X	X		X	X	X	X
RV1	MAIN RELIEF VALVE	X									
RV2	STEERING RELIEF				X	X					
V1	STEERING VALVE				X	X					
V2	COUNTERBALANCE VALVE		X	X				X			X
V3	LIFT VALVE	X	X					X	X		
V4	FORWARD / REVERSE VALVE	X						X			
V5	PROPORTIONAL VALVE		X	X				X			
V6	DOWN VALVE						X				
V7	POTHOLE EXTEND VALVE	X							X		
V8	POTHOLE RETRACT VALVE		X					X		X	

5.0 Introduction

This section contains electrical and hydraulic power schematics and associated information for maintenance purposes.

The diagrams are to be used in conjunction with the *Troubleshooting Truth Tables* in **Section 4**. They allow understanding of the makeup and functions of the systems for checking, tracing, and faultfinding during troubleshooting analysis.

The components that comprise the electrical and hydraulic systems are given a reference designation and are explained as to function and location in the following tables.

INDEX

Figure	Page
5-1: Electrical Schematic	5-3
5-2: Electrical Schematic (Proportional)	5-5
5-3: Hydraulic Schematic	5-7
5-4: Hydraulic Manifold	5-7

Table	Page
5-1: Electrical Schematic	5-2
5-2: Electrical Schematic (Proportional)	5-4
5-3: Hydraulic Schematic	5-6
5-4: Hydraulic Manifold	5-6

5.1 Electrical Schematic, Standard Toggle Controls

Table 5-1: Electrical Schematic Legend

REFERENCE DESIGNATION	NAME	FUNCTION	LOCATION
ALM	Alarm, Down/Tilt	Provides warning sound (60 Hz) when the platform is lowering. Provides warning sound(600Hz) when platform is elevated on slopes of 2° side to side and 2° fore and aft.	Bottom of lower Control box.
BAT	Batteries (4), 6 volts each	To store energy.	Inside power module.
CB	Circuit Breaker	Overload protection.	Chassis control panel.
CHG	Battery Charger	Charge Battery.	Chassis.
CONT	Controller	Logic for machine functions.	Control Module.
CR1	Relay, motor start	Starts motor.	Bottom of lower Controller.
CR1 (N O)	Relay, Contact	Starts motor	Bottom of lower Control box.
CR2 (N C)	Relay, Contact	Disconnect Battery Charger	Lower Control Box
FU1	Fuse, 175 AMP	Overload protection for the electric motor.	Lower Control box.
MOT	Motor, electric	Provides power to drive hydraulic pump.	Control module.
MTR	Meter, Hour (option)	Shows hours machine has operated.	Lower Control box.
S2	Switch, Platform	Forward/Reverse Up/Down	Platform Controller.
S4	Switch, Lift/Low Drive/High Drive selector.	Activates Lift/Low Drive/High functions.	Platform Controller
S5	Switch, Controller Emergency Stop Button.	Control circuit shut off.	Platform Controller.
S6	Switch, Steering	Provides power to either right or left steer valve solenoids.	Platform Controller.
S7	Switch, Foot	Enables drive and lift functions.	Platform.
S8	Switch, Up/Down	Provides power to Up/Down circuit.	Lower Control box.
S9	Switch, Chassis Key	Power on. Power to Chassis/ Platform functions.	Lower Control box.
S10	Switch, Chassis Emergency Stop.	Stop all machine functions.	Lower Control box.
S11	Switch, Proximity	Controls drive speed.	Behind front left wheel.

REFERENCE DESIGNATION	NAME	FUNCTION	LOCATION
SNSR	Sensor, Tilt	Activate tilt alarm Disable all machine functions except platform lower when machine is more than 2° off level.	Control module.
SOL1	Solenoid, Proportional	Controls proportional valve.	Manifold block.
SOL2	Solenoid, forward	Shifts forward/reverse valve to forward position.	Manifold block.
SOL3	Solenoid, reverse	Shifts forward/reverse valve to reverse position.	Manifold block.
SOL4	Solenoid, lift	Raise platform.	Manifold block.
SOL5	Solenoid, pothole extend	PHP extend	Manifold block.
SOL6	Solenoid, steer left	Shifts steer valve to LEFT turn position	Manifold block.
SOL7	Solenoid, steer right	Shifts steer valve to RIGHT turn position	Manifold block.
SOL8	Solenoid, down	Lowers platform.	Lift cylinder
SOL9	Solenoid, pothole retract	PHP retract	PHP cylinder

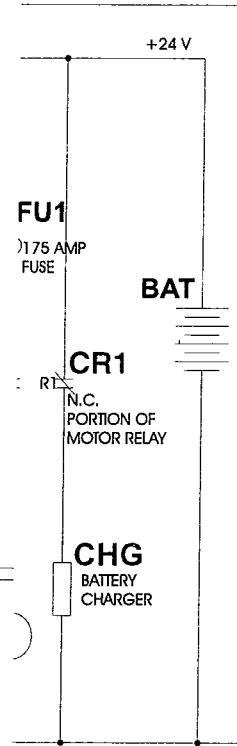
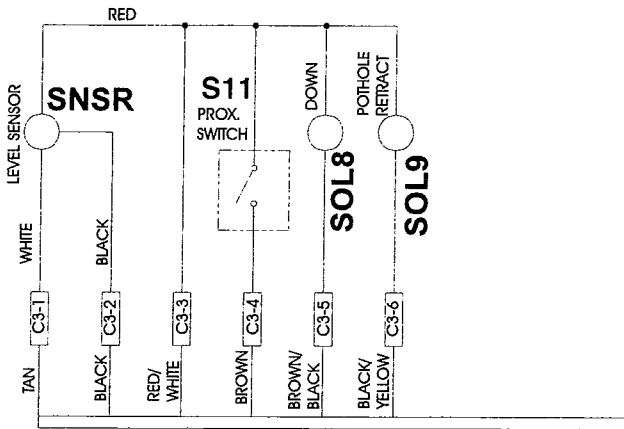

FUNCTION	SWITCHING PROCEEDURE
LIFT	S4A CLOSED, S4B OPEN
DRIVE	S4A OPEN, S4B CLOSED

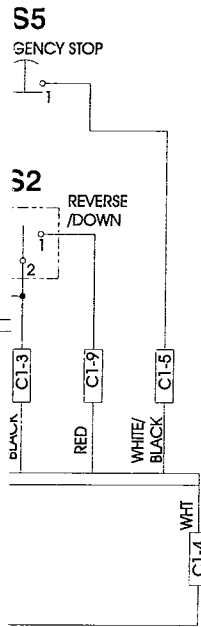
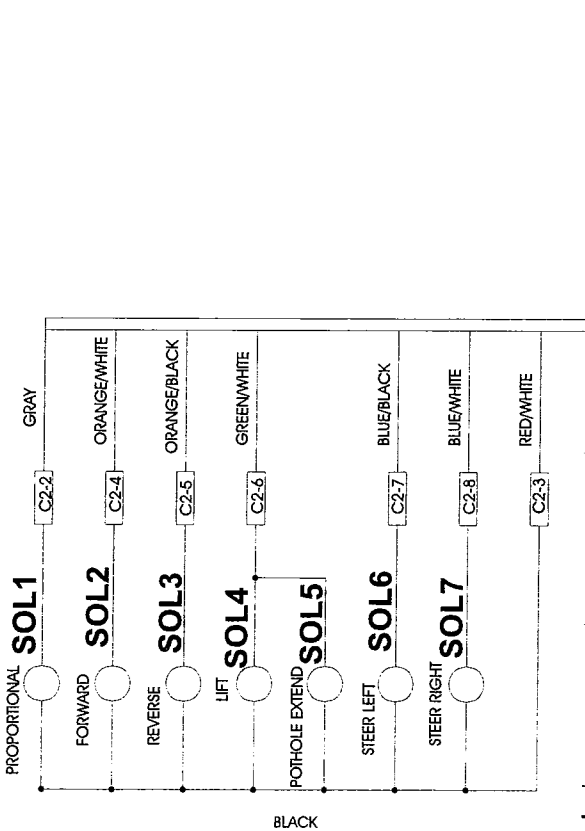

JpRight Drawing Number 101181-004

5.2 Electrical Schematic, Optional Proportional Controls

Table 5-2: Electrical Schematic Legend (SL20 Proportional)

REFERENCE DESIGNATION	NAME	FUNCTION	LOCATION
ALM	Alarm, Down/Tilt	Provides warning sound (60 Hz) when the platform is lowering. Provides warning sound(600Hz) when platform is elevated on slopes of 2° side to side and 2° fore and aft.	Bottom of lower Control box.
BAT	Batteries (4), 6 volts each	To store energy.	Inside power module.
CB	Circuit Breaker	Overload protection for the control circuit.	Chassis control panel.
CHG	Battery Charger.	Charge Battery	Chassis
CONT1	Joystick Controller	Logic for joystick functions.	Upper control box
CONT2	Controller	Logic for machine functions.	Control Module
CR1	Relay, motor start	Starts Motor	Bottom of lower Controller.
CR1 (N O)	Contact Relay	Starts motor	Bottom of lower Control box.
CR2 (N C)	Relay, Contact	Disconnect Battery Charger	Lower Control Box
FU1	Fuse, 175 AMP	Overload protection for the electric motor.	Lower Control box.
JOYS	Joystick	Activate proportion Lift/Drive.	Upper Control box.
MOT	Motor, electric	Provides power to drive hydraulic pump.	Control module.
MTR	Meter, Hour (option)	Shows hours machine has operated.	Lower Control box.
S1	Switch, Joystick	Provides power to Joystick + terminal and Motor start relay through Joystick circuit board.	Front switch closest to center of joystick when joystick is held in assembled position.
S2	Switch, Joystick Down/Reverse	Provides power to Drive/Lift circuit when Joystick is pushed forward.	Left front switch on Joystick when Joystick is held in assembled position.
S3	Switch, Joystick Lift/Forward	Provides power to Drive/Lift circuit when Joystick is pushed forward.	Left rear switch on Joystick when Joystick is held in assembled position.

REFERENCE DESIGNATION	NAME	FUNCTION	LOCATION
S4	Switch, Lift/Low Drive/High Drive selector.	Activates Lift/Low Drive/High functions.	Platform Controller.
S5	Switch, Platform Emergency stop.	Control circuit shut off.	Platform Controller.
S6	Switch, Steering	Provides power to either right or left steer valve solenoids.	Rocker actuator on top of Joystick.
S7	Switch, Interlock Lever	Provides power to Controller.	On front of Joystick.
S8	Switch, Up/Down	Provides power to Up/Down circuit.	Lower control box.
S9	Switch, Chassis Key	Provides power to either the chassis lift switch or the controller.	Lower control box.
S10	Switch, Chassis Emergency Stop.	Control circuit shut off.	Lower control box.
S11	Switch, Proximity	Switches from High to Low drive speed when platform is elevated.	Behind front left wheel.
SNSR	Sensor, Tilt	Activate tilt alarm Disable all machine functions except platform lower when machine is more than 2° off level.	Control module.
SOL1	Solenoid, Proportional	Controls proportional valve.	Manifold block.
SOL2	Solenoid, forward	Shifts forward/reverse valve to forward position.	Manifold block.
SOL3	Solenoid, reverse	Shifts forward/reverse valve to reverse position.	Manifold block.
SOL4	Solenoid, lift	Raise Platform.	Manifold block.
SOL5	Solenoid, pothole extend	Extends PHP bar.	Manifold block.
SOL6	Solenoid, steer left	Shifts steer valve to LEFT turn position	Manifold block.
SOL7	Solenoid, steer right	Shifts steer valve to RIGHT turn position	Manifold block.
SOL8	Solenoid, down	Lowers platform.	Lift cylinder
SOL9	Solenoid, pothole retract	Retracts PHP bar.	PHP cylinder

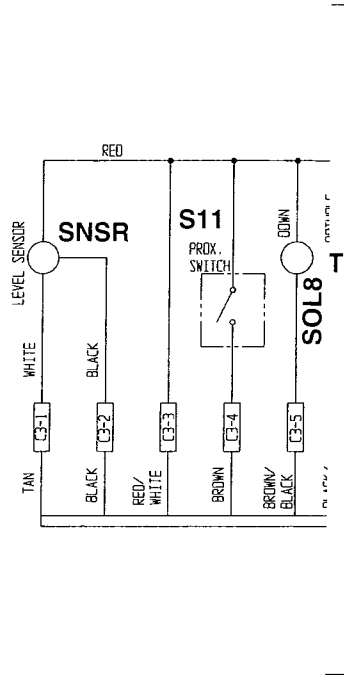

S4	OPEN	CLOSED
LIFT	S4A, S4B	S4C
DRIVE	S4C	S4A, S4B

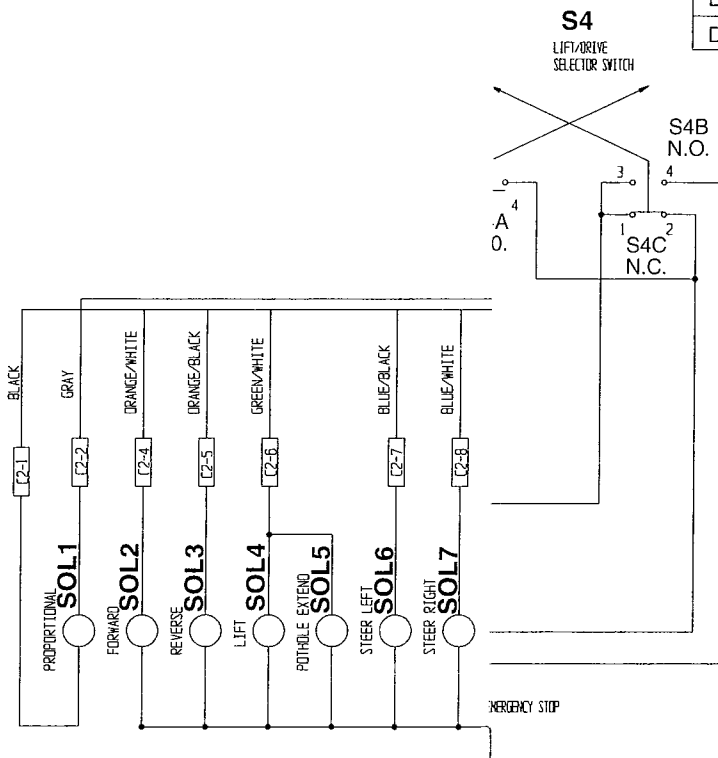

UpRight Drawing Number 101181-006

5.3 Hydraulic Schematic

Table 5-3: Hydraulic Schematic Legend

REFERENCE DESIGNATION	NAME	FUNCTION	LOCATION
CV1	Check Valve, Pothole Protection	Allows Pothole Cylinder to retract in drive mode.	Left side center of manifold block.
CYL1	Cylinder, Steering	Provides force to turn front wheels.	Front of chassis above Drive Motors.
CYL2	Cylinder, Brake	Stops machine from moving while parked.	Front of Chassis above front tires.
CYL3	Cylinder, Lift	Provides force to lift platform.	Mounted under upper boom weldment.
CYL4	Cylinder, Pothole Protection	Extend/Retract PHP Bar	In front of Hydraulic Tank.
FL1	Filter	Filters oil returning to tank.	Back of Hydraulic tank.
FL2	Suction Screen	Traps particles in hydraulic tank.	Inside hydraulic tank at outlet.
FD1	Flow Divider	Provides priority oil flow to steering.	Front of manifold block.
MOT1	Drive Motor	Provides tractive effort to move work platform.	At left front motor mount.
MOT2	Drive Motor	Provides tractive effort to move work platform.	At right front motor mount.
ORF1	Orifice, Down	Controls the platform rate of descent.	Lift Cylinder
ORF2	Orifice, Lift	Controls the platform rate of ascent.	Under lift port fitting , top of manifold Block
PMP	Pump	Supplies hydraulic oil flow for all functions.	On Electric Motor at left rear of control module.
RV1	Valve, Main Relief	Provides over pressure protection to pump and limits platform lifting capacity.	Left side of manifold block, upper center.
RV2	Valve, Steering Relief	Provides over pressure protection to pump and steering components when steering.	Bottom of manifold block.

REFERENCE DESIGNATION	NAME	FUNCTION	LOCATION
V1	Valve, Steering cylinder.	Provides directional control for steering	Left side front of manifold block
V2	Valve, Counterbalance	Prevents machine from running away on slopes and cushions stops.	Left side of manifold block, near upper right corner.
V3	Valve, Lift	Provides control of oil for drive or lift functions.	Left side of manifold block, near left of center.
V4	Valve, Forward/Reverse	Provides control of oil for forward or reverse drive.	Left side of manifold block, right of center.
V5	Valve, Proportional	Controls oil flow into drive and lift circuits by proportionally dumping oil back to tank.	Left side of manifold block, bottom right corner.
V6	Valve, Down and Emergency Lowering.	Allows oil to flow out of lift cylinder to tank, manually operated for emergency lowering.	Lift Cylinder.
V7	Valve, Pothole Extend	Provides control of oil for Pothole Protection Bar.	Left side of manifold block, right of center.
V8	Valve, Pothole Retract	Provides control of oil for Pothole Protection Bar.	Pothole Protection cylinder.

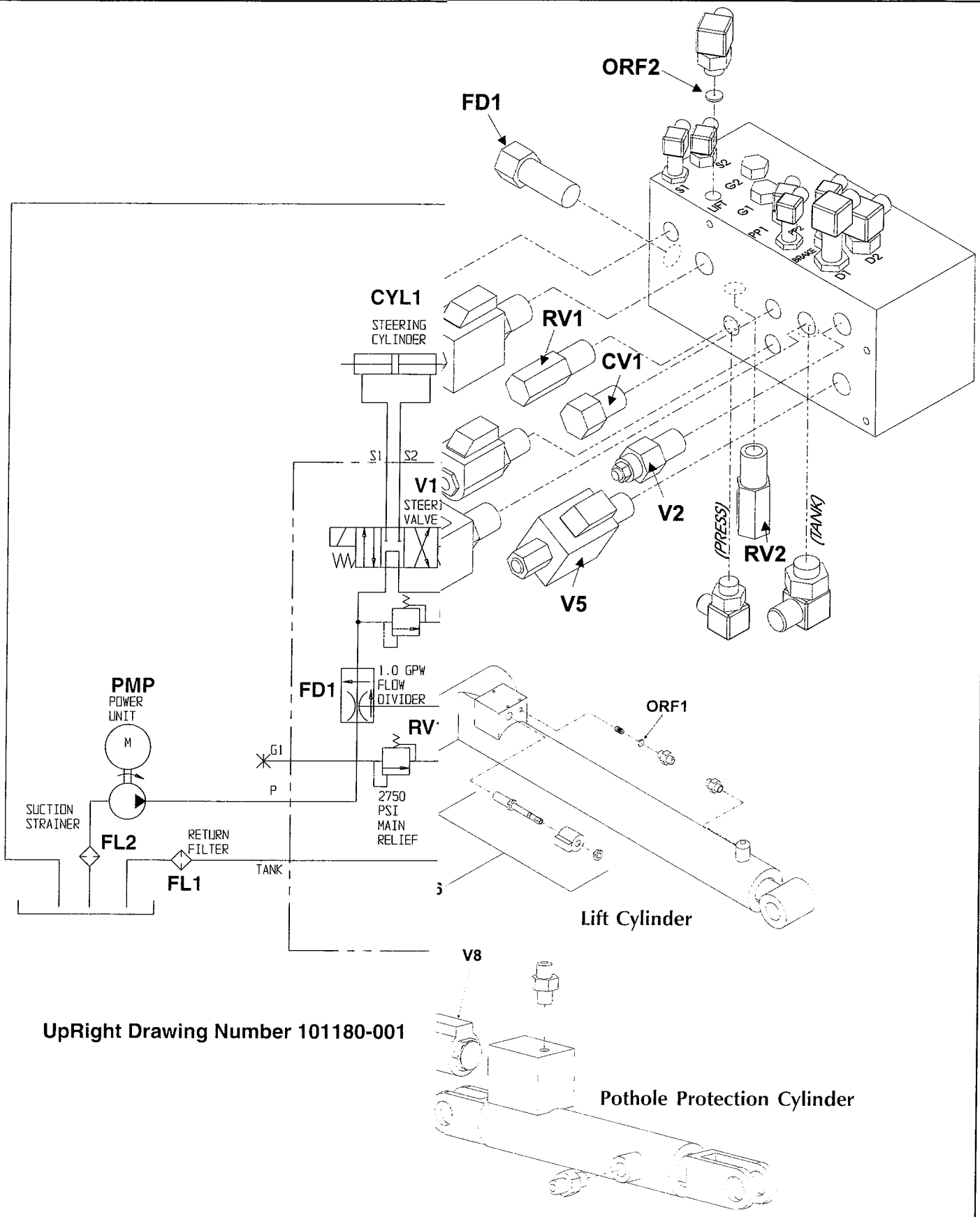

UpRight Drawing Number 101180-001

Figure 5-4: Hydraulic Manifold

NOTES

6.0 Introduction

This section lists and illustrates the replaceable assemblies and parts of the SL20 Work Platform, as manufactured by UpRight, Inc.

Each parts list contains the component parts for that assembly indented to show relationship where applicable.

6.1 Index

Assembly	Page
Final Assembly	
101000-010	6-2
Basic Assembly	
101001-001	6-5
Chassis Assembly	
101002-000	6-6
Linkage Assembly	
101004-001	6-10
Control Module Assembly	
101005-001	6-12
Power Module Assembly	
101003-000	6-14
Control Valve Assembly	
101120-020	6-16
Controller Assembly Toggle	
101155-001	6-18
Platform Assembly	
101007-000	6-20
Hose Kit Installation	
101179-001	6-21
Lower Controls Assembly	
101154-001	6-22
Control Cable Assembly	
101021-000	6-24
Hydraulic Tank Assembly	
101152-000	6-25
Label Kit Installation	
101009-000	6-26
3 Ft. Roll-out Deck Extension - Option	
101008-000	6-27
Gate Interlock Option	
101249-000	6-28
Power To Platform - Option	
101196-000	6-30
Air To Platform - Option	
101197-000	6-31
Horn - Option	
101190-000	6-32
Proportional Controller - Option	
101194-001	6-34
Hour Meter With Battery Low Voltage Indicator - Option	
101195-000	6-36
Hour Meter - Option	
101191-000	6-37
Motion Alarm - Option	
101193-000	6-38

FINAL ASSEMBLY

SL20

101000-010

ITEM	PART	DESCRIPTION	QTY.
1	101001-001	BASIC ASSEMBLY	1
2	101003-000	POWER MODULE ASSEMBLY	1
3	101005-001	CONTROL MODULE ASSEMBLY	1
7	101155-001	CONTROLLER ASSEMBLY	1
10	011254-012	SCREW, 3/8-16 UNC HEX HD CAP X 1 1/2	4
11	011254-006	SCREW, 3/8-16 UNC HEX HD CAP X 3/4	2
13	101180-001	HYDRAULIC SCHEMATIC	REF
14	101181-004	ELECTRICAL SCHEMATIC	REF
15	101179-001	HOSE KIT/INSTALLATION	1
16	101009-000	DECAL KIT / INSTALLATION	1
17	101021-000	CONTROL CABLE ASSEMBLY	1
18	101162-000	WIRE HARNESS, CHASSIS	1
19	101007-000	PLATFORM ASSEMBLY	1
20	029418-099	WIRE, 12 GA RED/BLK	5 FT
21	101028-000	SHIM, 16 GA.	AR
23	101010-000	PIN LINK TO PLATFORM	2
24	065214-000	ROD END	2

ITEM	PART	DESCRIPTION	QTY.
25	064195-065	CABLE ASSEMBLY X 65	1
26	064195-044	CABLE ASSEMBLY X 44	1
27	064195-001	CABLE ASSEMBLY X 12	3
28	062125-011	CABLE ASSEMBLY X 9	1
29	064195-004	CABLE ASSEMBLY X 4	1
30	029461-099	WIRE, 14 GA BLACK	10 FT
31	010154-000	COVER, BATTERY TERMINAL	8
32	029620-002	CONNECTOR, BUTT 16-14GA	1
33	029620-003	CONNECTOR, BUTT 12-10GA INSL.	1
34	029601-015	CONNECTOR, RING 14-16 GA 3/8 DIA	3
35	101107-000	LADDER WELDMENT	2
36	029418-099	WIRE, 12GA RED/BLK	6 FT
37	101028-001	COMPRESSION SHIM, 18GA	2
38	101028-002	COMPRESSION SHIM, 20GA	3
39	029601-021	CONNECTOR, RING 12-10GA 3/8 DIA	3
41	029610-018	CONN, FORK 12-10 GA. #8	1
43	029470-099	WIRE, 12 AWG STRD RED	.5 FT
47	029461-099	WIRE, BLK 14 AWG	.5 FT

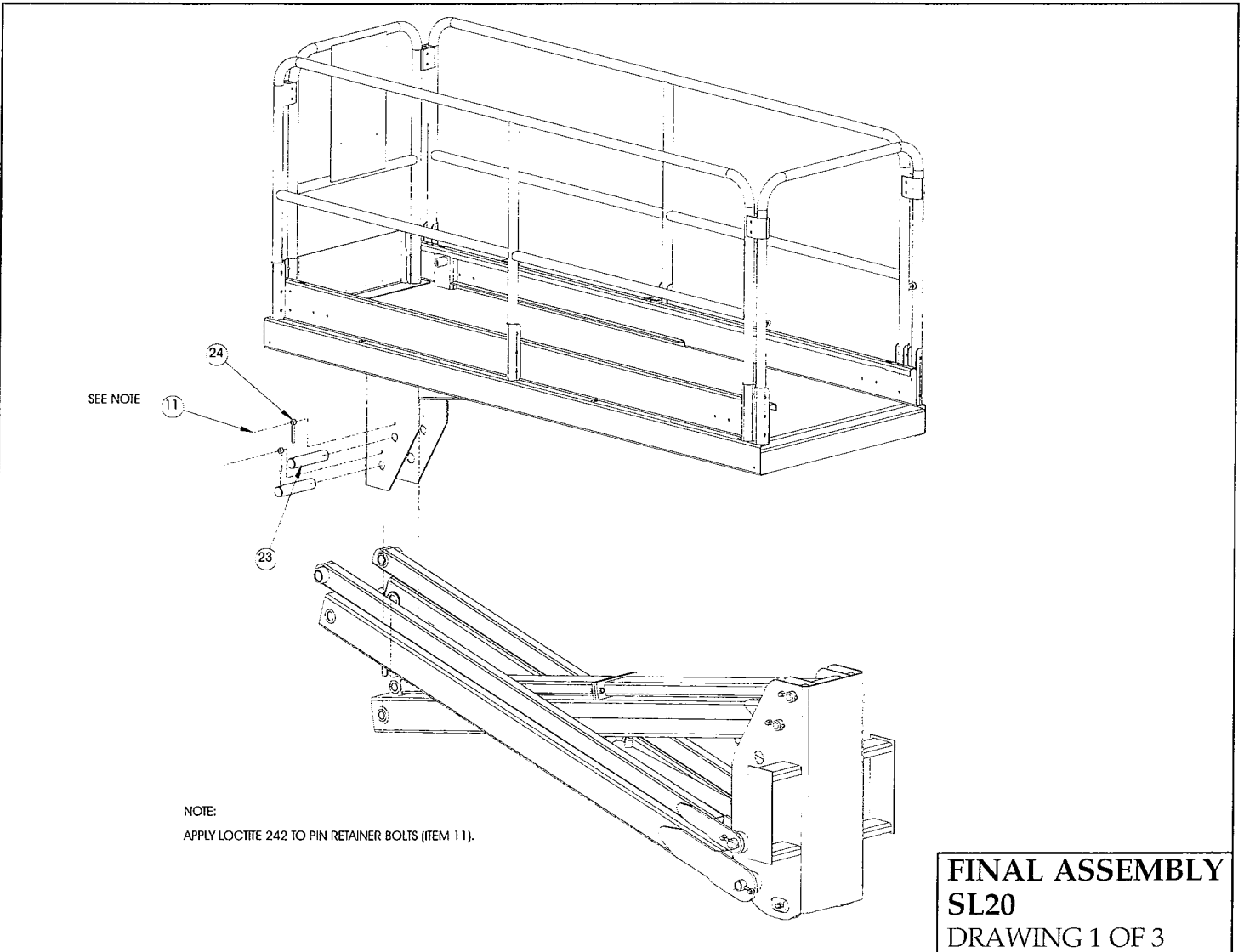

Illustrated Part

NOTES:

1. HYDRAULIC PRESSURE:
SETTING MAIN RELIEF--SET TO 2750 PSI +50 -0
COUNTERBALANCE VALVE--SET TO 800-1000 PSI
STEERING RELIEF--SET TO 1000 PSI
9. SHIM AS REQUIRED TO LEVEL PLATFORM $\pm .75^{\circ}$ (1 1/4")

POTHOLE PROTECTION SYSTEM ADJUSTMENT

1. PLACE MACHINE ON LEVEL SURFACE $\pm 1/4^{\circ}$
2. RAISE MACHINE FOR ACCESS TO LEVEL SENSOR.
3. CENTER LEVEL SENSOR BUBBLE BY TURNING ADJUSTMENT SCREWS ON LEVEL SENSOR.

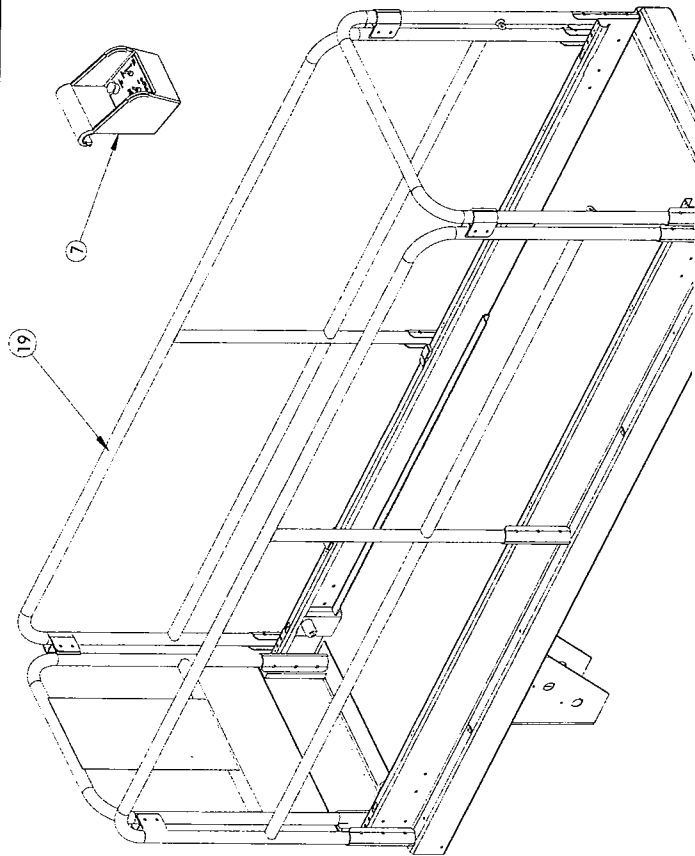

(1)

s Breakdown

FINAL ASSEMBLY
SL20
 DRAWING 3 OF 3
 (Toggle Assembly Shown)

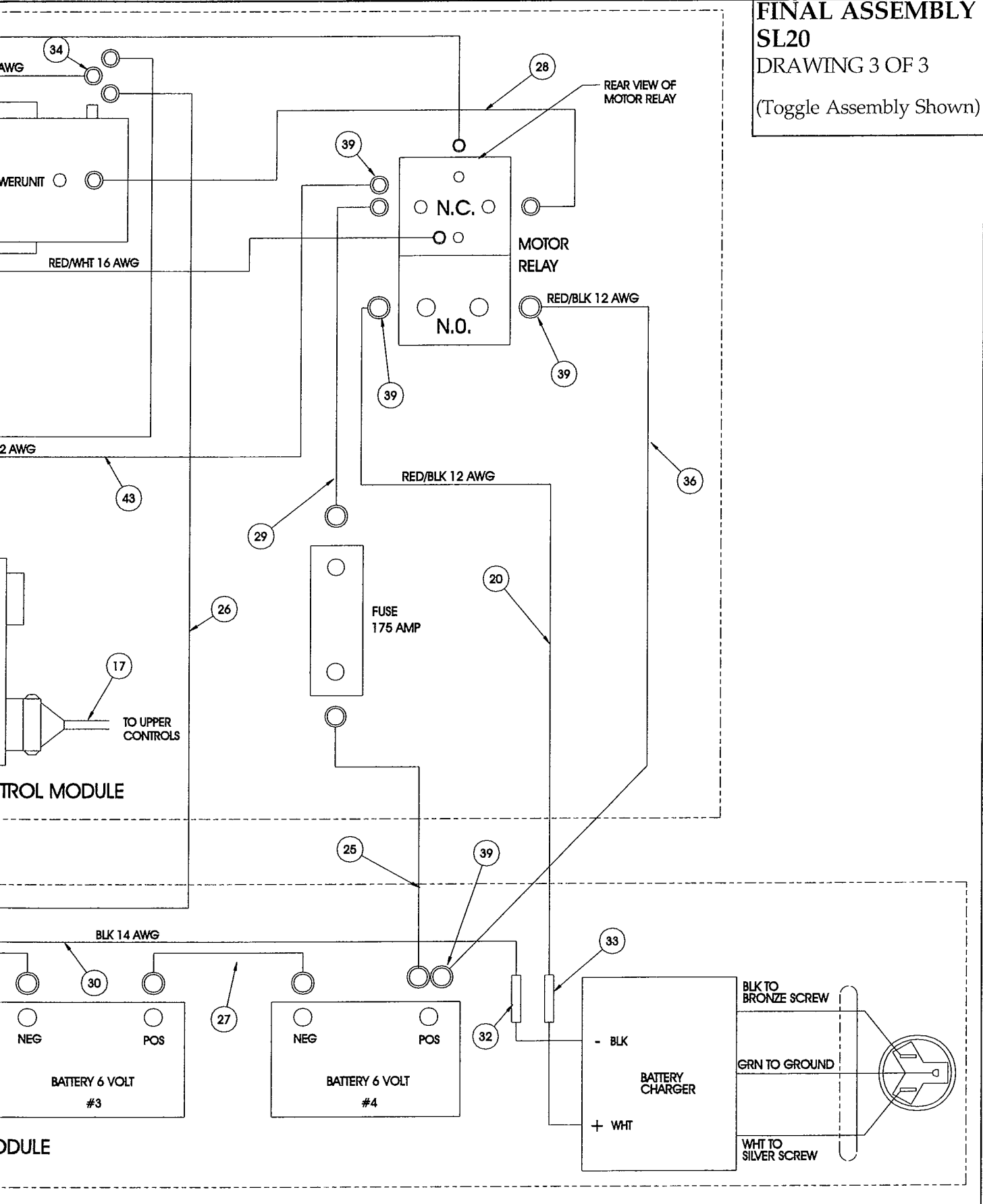

Illustrated Parts Breakdown

BASIC ASSEMBLY

SL20

101001-001

ITEM	PART	DESCRIPTION	QTY.
1	101002-001	CHASSIS ASSEMBLY	1
2	101004-001	LINKAGE ASSEMBLY	1
4	065770-000	BRACKET, CABLE	1
5	101042-000	PIN WELDMENT	2
7	101224-000	SHIM	2
8	011252-004	SCREW, 1/4-20 UNC HEX HD CAP X 1/2	3
9	011238-004	LOCKWASHER, 1/4 DIA SPLIT	3
11	065754-005	CABLE, EMERGENCY DOWN X 12'	1
12	011256-008	SCREW, 1/2-13 UNC HEX HD CAP X 1	2
13	011238-008	LOCKWASHER, 1/2 DIA SPLIT	2
14	013283-002	CABLE MOUNT	3

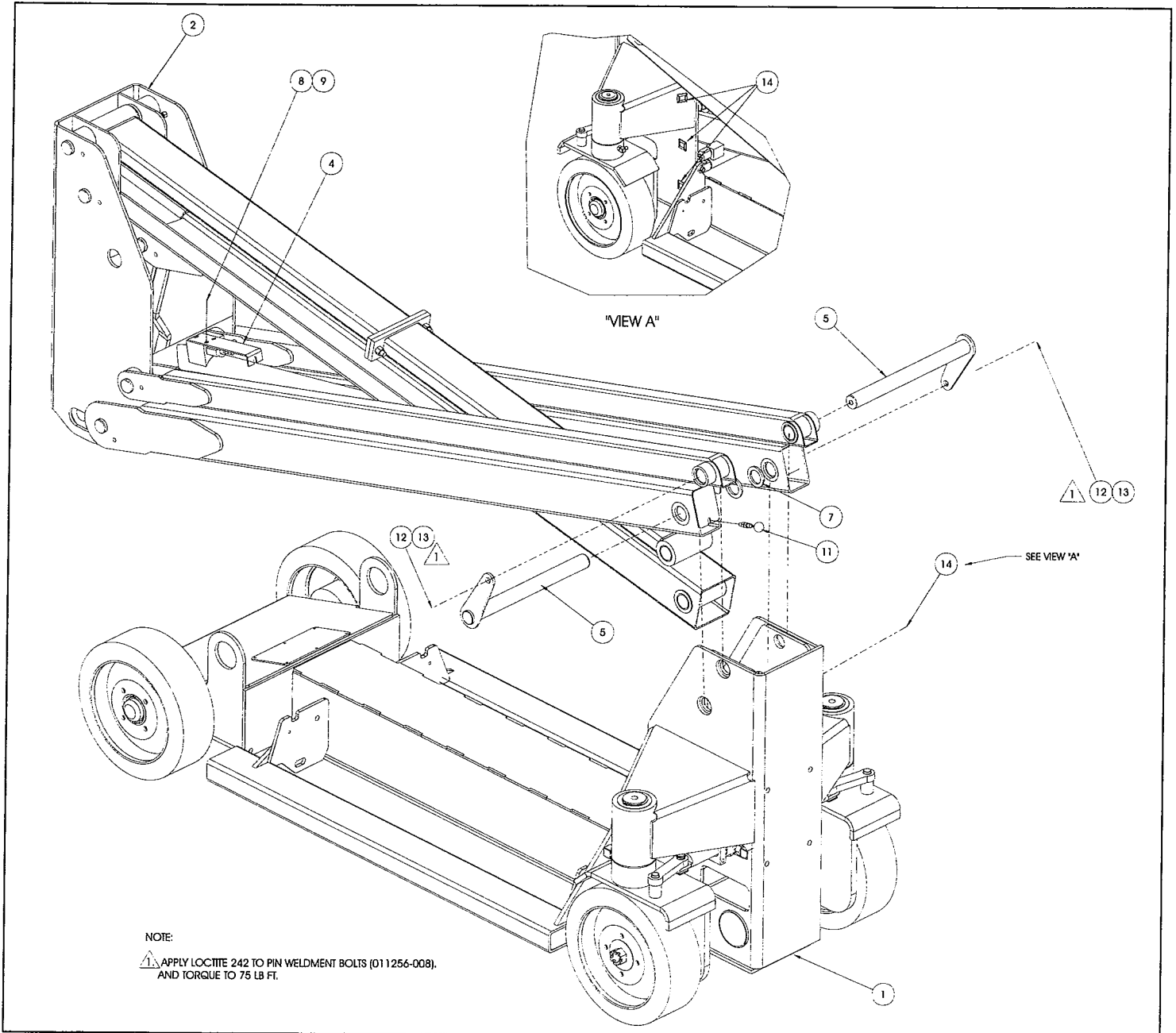

CHASSIS ASSEMBLY

SL20

101002-000

ITEM	PART	DESCRIPTION	QTY.
1	101072-000	CHASSIS WELDMENT	1
2	101065-000	MOTOR MOUNT WELDMENT R.H.	1
3	101066-000	MOTOR MOUNT WELDMENT L.H.	1
4	065371-000	STEERING CYLINDER	1
-	065371-011	STEERING CYLINDER SEAL KIT	-
5	101089-000	STEERING ARM	2
6	101125-000	DRIVE MOTOR	2
-	101125-010	DRIVE MOTORSEAL KIT	-
7	066325-000	HUB, FRONT	2
8	061846-001	RIM ASSEMBLY	4
9	101014-000	POTHOLE CYLINDER	1
-	101014-010	POTHOLE CYLINDER SEAL KIT	-
10	101083-000	POTHOLE TUBE WELDMENT R.H.	1
11	101084-000	POTHOLE TUBE WELDMENT L.H.	1
12	101015-000	BRAKE CYLINDER	2
-	101015-010	BRAKE CYLINDER SEAL KIT	-
13	063109-099	COUNTERWEIGHT	-
14	065800-000	STEERING PIN	2
15	065732-000	STEERING BEARING FLANGE	2
16	101157-000	BRAKE RETAINING WASHER	2
17	011764-038	RETAINING RING	2
18	066183-003	BEARING, 3/4 I.D. X 7/8 O.D. X 1/2 LG	6
19	066773-000	HUB ASSEMBLY	2
20	101216-000	COVER, WEIGHT HOLE	1
21	011776-004	CUP, BEARING	4
22	011274-016	NUT, SLOTTED HEX	4
23	011775-011	CONE, BEARING	4
24	005104-000	SEAL, GREASE	2
25	011239-016	WASHER, 1 DIA FLAT ASTM	2
26	005078-000	DUST CAP	2
27	063973-001	POTHOLE VALVE 20VDC	1
28	011934-001	FITTING, ELBOW	2
29	013315-010	RETAINING RING	2
30	011941-001	FITTING, STRAIGHT	2
31	013919-004	HOSE CLAMP	2

ITEM	PART	DESCRIPTION	QTY.
32	101128-000	SPINDLE THRUST WASHER	2
33	011240-004	WASHER, 1/4-20 STD FLAT	1
34	027931-022	BEARING	1
35	101127-000	SPINDLE BEARING	2
36	011753-012	COTTER PIN, 1/8 X 1 1/2	4
37	011254-032	SCREW, 3/8-16 UNC HEX HD CAP X 4	4
38	011240-006	WASHER, 3/8 DIA STD FLAT	4
39	011248-006	LOCKNUT, 3/8-16 UNC HEX	4
40	011248-008	LOCKNUT, 1/2-13 UNC HEX	16
41	011256-026	SCREW, 1/2-13 UNC HEX HD CAP X 3 1/4	8
42	027931-072	BEARING	2
43	011240-008	WASHER, 1/2 DIA STD FLAT	8
44	018081-008	POTHOLE SPACER(TUBE,.75O.D.X.120WX1 12)	4
45	011254-012	SCREW, 3/8-16 UNC HEX HD CAP X 1 1/2	8
46	014122-003	BOLT, WHEEL	16
48	101051-000	PIN WELDMENT, POTHOLE CYLINDER	2
49	011752-010	PIN, COTTER3/32 X 1 1/4LG	2
50	012030-024	SCREW,1/2-13 UNC SOC HD ALLOY ORIGR 8X3	4
51	011934-001	FITTING, ELBOW	2
52	020032-001	FITTING, TEE	1
53	068885-001	FITTING, SWIVEL ELBOW	4
54	011258-016	SCREW, 3/4-10 UNC HEX HD CAP X 2	4
55	011248-012	LOCKNUT, 3/4-10 UNC HEX	4
56	011709-008	SCREW, 10-24 UNC RD HD MACH X 1	2
57	011248-003	LOCKNUT, 10-24 UNC HEX	2
58	026554-004	RIVET, POP 1/8	2
59	011240-003	WASHER, #10 STD FLAT	2
60	101201-000	PROXIMITY BRACKET	1
61	101151-000	PROXIMITY SWITCH	1
62	026554-003	RIVET, POP 1/4	6
63	068706-000	CLAMP HOSE	1
64	011248-004	LOCKNUT, 1/4-20 UNC HEX	2

Illustrated Parts Breakdown

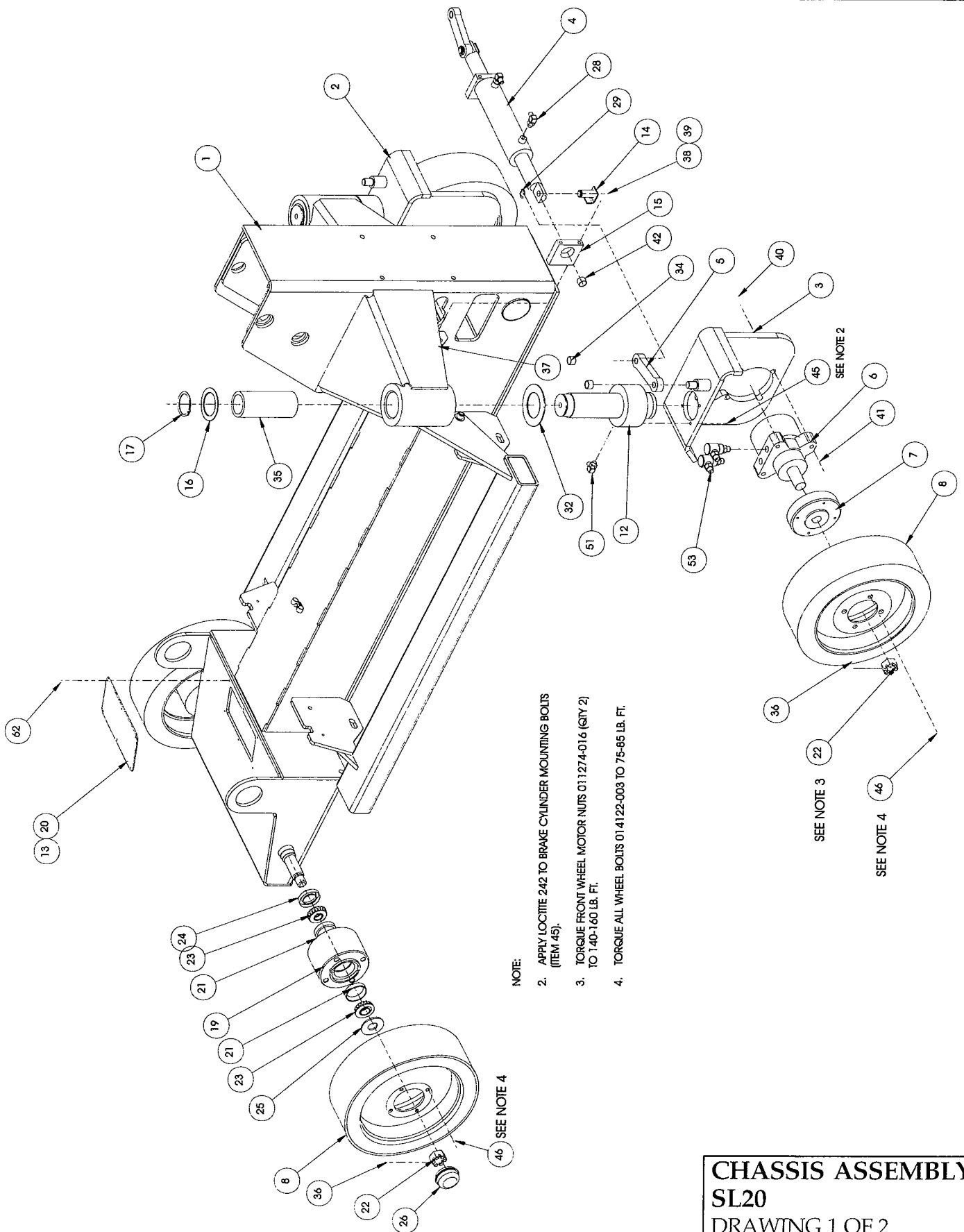

CHASSIS ASSEMBLY
SL20
DRAWING 1 OF 2

Illustrated Parts Breakdown

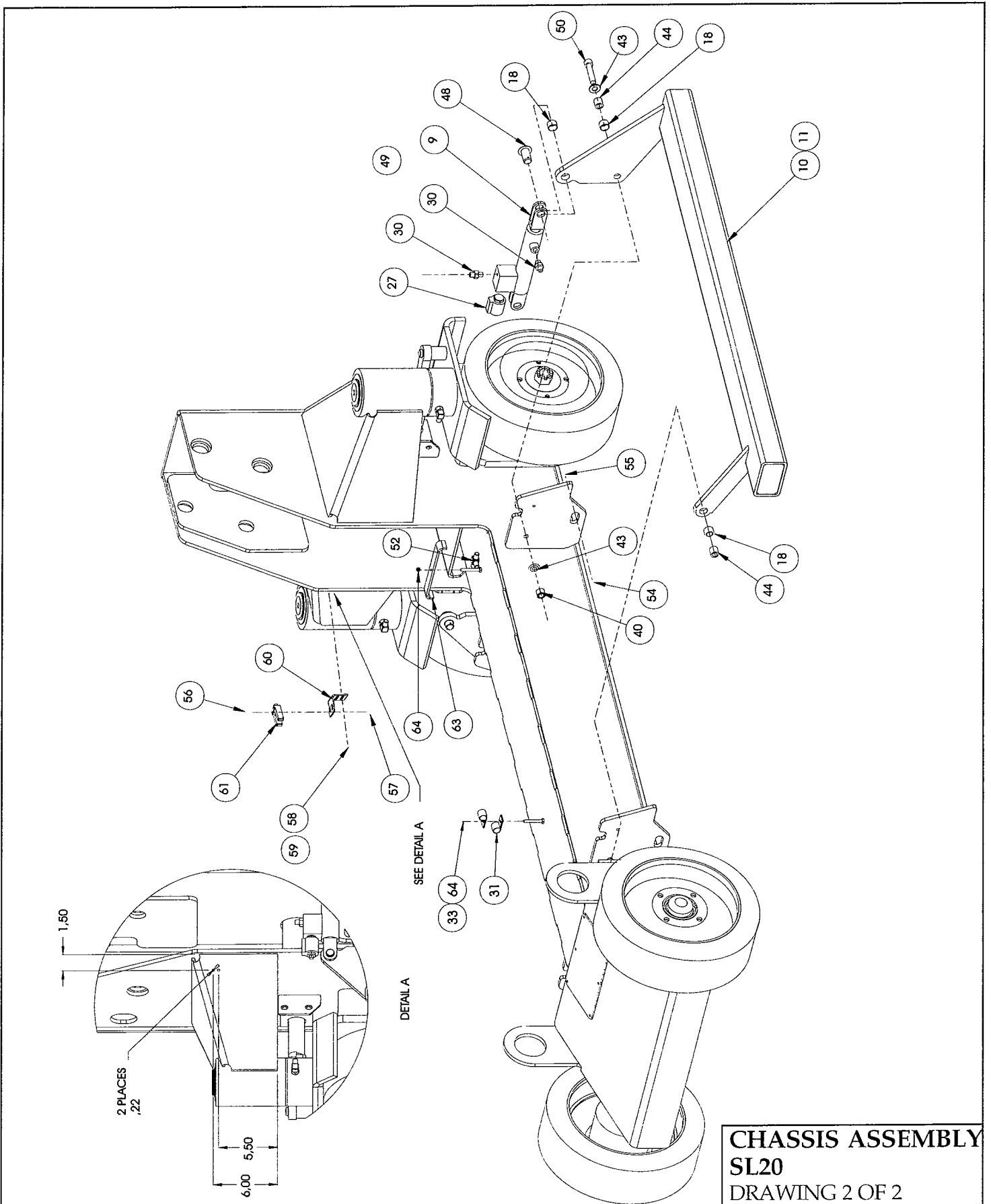

NOTES:

LINKAGE ASSEMBLY

SL20

101004-001

ITEM	PART	DESCRIPTION	QTY.
1	101036-000	PIN	1
2	101037-000	PIN	2
3	101039-000	PIN	1
4	101040-000	PIN	2
5	101030-000	LOWER BOOM WELDMENT L.H.	1
6	101023-000	ADJSTBLE COMPRSSION TUBE WLDMENT	2
7	101035-001	LOWER TENSION LINK WELDMENT L.H.	1
8	101031-000	LOWER BOOM WELDMENT R.H.	1
9	101016-001	BUSHING- 3" LG	7
10	101059-000	UPPER BOOM WELDMENT	1
11	101048-000	RISER WELDMENT	1
12	101053-000	TENSION LINK WELDMENT	1
13	101013-000	LIFT CYLINDER	1
-	101013-010	LIFT CYLINDER SEAL KIT	-
14	101016-000	BUSHING- 2" LG	16
15	065214-000	ROD END	7
16	011254-012	SCREW, 3/8-16 UNC HEX HD CAP X 1 1/2	7
17	011248-006	LOCKNUT, 3/8-16 UNC HEX	7
18	011248-008	LOCKNUT, 1/2-13 UNC HEX	2
19	011256-018	SCREW, 1/2-13 UNC HEX HD CAP X 2 1/4	2
21	011941-005	FITTING, STRAIGHT	2
22	101204-000	PIN	1
23	101035-000	LOWER TENSION LINK WELDMENT R.H.	1
24	013987-010	SPRING	1
25	015919-000	ORIFICE (Ø .0465)	1
26	066179-000	VALVE, LOWERING 20 VDC	1
27	061692-099	EDGE TRIM 3/16	FT 2.6
28	067805-099	EDGE TRIM 1/4-1/2	FT .90

Illustrated Parts Breakdown

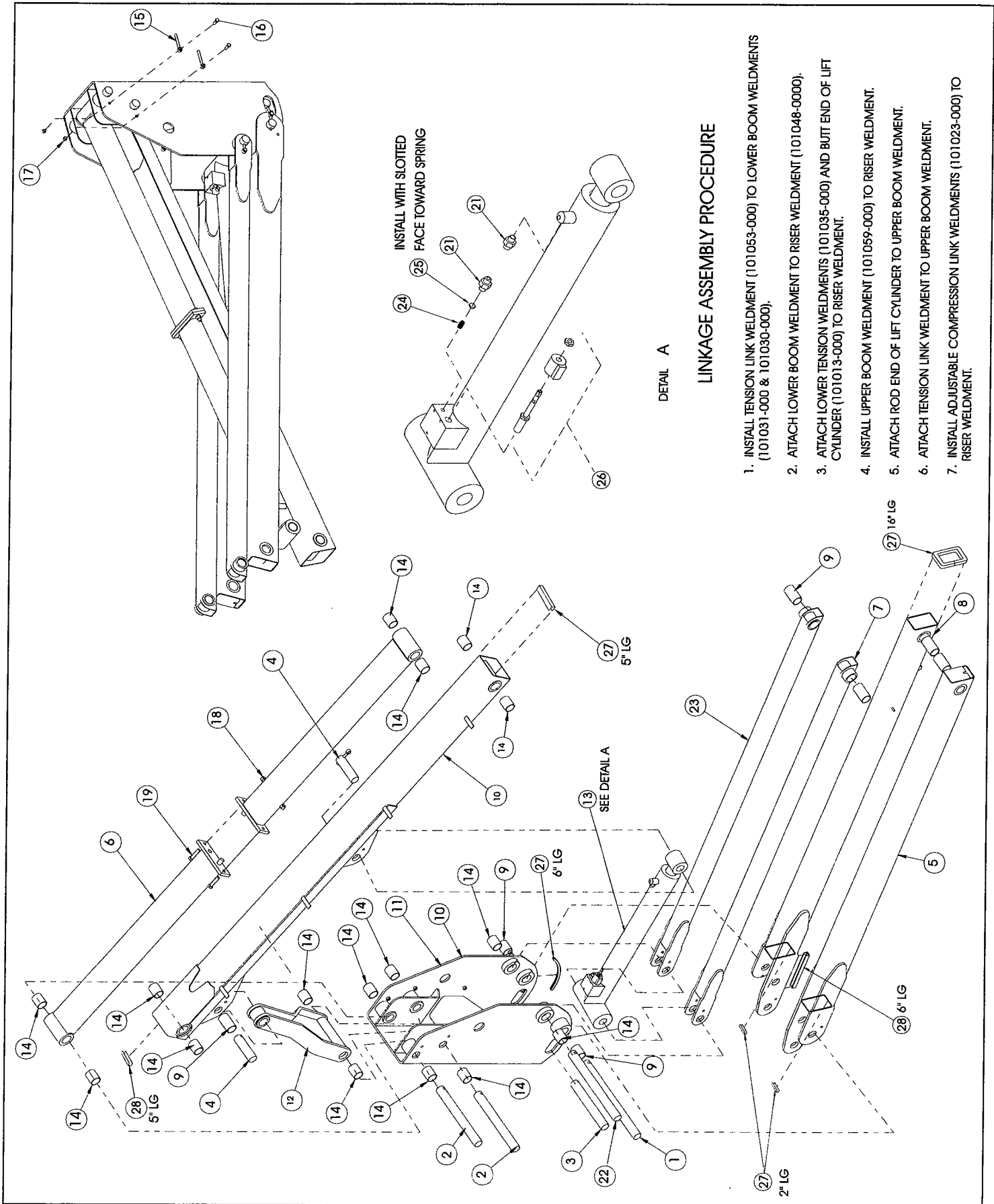

LINKAGE ASSEMBLY PROCEDURE

1. INSTALL TENSION LINK WELDMENT (101053-000) TO LOWER BOOM WELDMENTS (101031-000 & 101030-000).
2. ATTACH LOWER BOOM WELDMENT TO RISER WELDMENT (101048-0000).
3. ATTACH LOWER TENSION WELDMENTS (101035-000) AND BUTT END OF LIFT CYLINDER (101013-000) TO RISER WELDMENT.
4. INSTALL UPPER BOOM WELDMENT (101059-000) TO RISER WELDMENT.
5. ATTACH ROD END OF LIFT CYLINDER TO UPPER BOOM WELDMENT.
6. ATTACH TENSION LINK WELDMENT TO UPPER BOOM WELDMENT.
7. INSTALL ADJUSTABLE COMPRESSION LINK WELDMENTS (101023-000) TO RISER WELDMENT.

CONTROL MODULE ASSEMBLY

SL20

101005-001

ITEM	PART	DESCRIPTION	QTY.
1	101146-000	CONTROL MODULE TRAY	1
2	101141-000	MODULE COVER WELDMENT	1
3	101145-000	CONTROL MODULE TOP	1
4	101230-000	POWER UNIT	1
5	101120-020	CONTROL VALVE	1
6	010122-001	RELAY, 24 VDC SPDT	1
7	005154-001	FILTER	1
8	101152-000	HYDRAULIC TANK ASSEMBLY	1
9	101153-002	BRACKET, VALVE BLOCK	1
10	101154-001	LOWER CONTROLS ASSEMBLY	1
11	005299-000	LATCH, TOGGLE	2
12	025427-002	HANDLE	1
13	101227-000	FITTING, ELBOW 45° 12MJ-8MB	1
14	011934-004	FITTING, ELBOW 90° 6MJ-6MB	1
15	011940-034	FITTING, ELBOW 90° 12MP-6MJ	1
16	011708-004	SCREW, #8-32 UNC RD HD MACH X 1/2	8
17	011248-003	LOCKNUT, #10-24 UNC HEX	6
18	011248-002	LOCKNUT, #8-32 UNC HEX	8
19	011252-040	SCREW, 1/4-20 UNC HEX HD CAP X 4 1/2	3
20	011248-004	LOCKNUT, 1/4-20 UNC HEX	15
21	011240-004	WASHER, 1/4 STD FLAT	4
22	011254-008	SCREW, 3/8-16 UNC HEX HD CAP X 1	2
23	011248-006	LOCKNUT, 3/8-16 UNC HEX	6
24	011709-006	SCREW, #10-24 UNC RD HD MACH X 3/4	4
25	011254-010	SCREW, 3/8-16 UNC HEX HD CAP X 1 1/4	4
26	011240-006	WASHER, 3/8 STD FLAT	4
27	011252-006	SCREW, 1/4-20 UNC HEX HD CAP X 3/4	6
28	011252-008	SCREW, 1/4-20 UNC HEX HD CAP X 1	2
29	026553-004	RIVET, 1/8 X 1/4-3/8 GRIP	4
30	064466-015	CABLE ASSEMBLY	1
31	011829-006	BOLT, 1/4-20 UNC CARRIAGE X 3/4	1
32	101163-001	WIRE HARNESS, VALVE BLOCK	1
33	029945-011	TILT SENSOR	1
34	066516-000	PLUG, 2.09-2.125	1
35	064464-000	CABLE RETAINER	1
39	066516-002	PLUG, 1.75	1

Illustrated Parts Breakdown

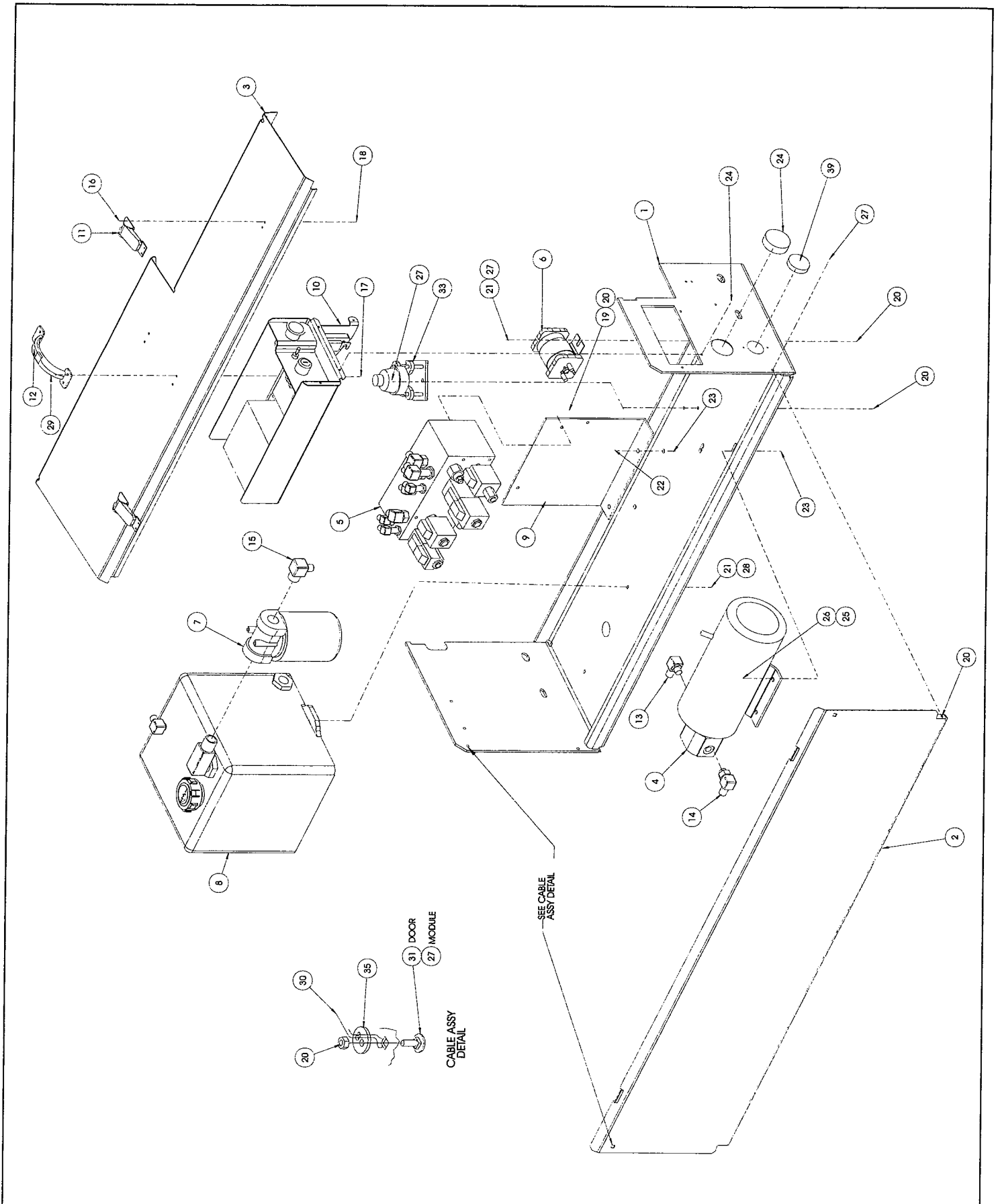

POWER MODULE ASSEMBLY

SL20

101003-000

ITEM	PART	DESCRIPTION	QTY.
1	101215-000	POWER MODULE TRAY WELDMENT	1
2	101141-000	MODULE COVER WELDMENT	1
3	101143-000	POWER MODULE TOP	1
4	015796-000	BATTERY,	4
5	063944-011	CHARGER	1
6	005299-000	LATCH, TOGGLE	2
7	025427-002	HANDLE	1
8	011252-006	SCREW, 1/4-20 UNC HEX HD CAP 3/4	2
9	011248-004	LOCKNUT, 1/4-20 UNC HEX	6
10	011829-006	BOLT, 1/4-20 UNC CARRIAGE X 3/4	1
11	011240-004	WASHER, 1/4 DIA STD FLAT	2
12	026553-004	RIVET, 1/8 1/4-3/8 GRIP	4
13	011708-004	SCREW, #8-32 UNC RD HD MACH X 1/2	8
14	011248-002	LOCK NUT #8-32 UNC HEX	8
15	011238-004	LOCKWASHER, 1/4 DIA SPLIT	4
16	011252-010	SCREW, 1/4-20 UNC HEX HD CAP 1 1/4	4
17	064466-015	CABLE ASSEMBLY	1
18	101214-000	HOLD DOWN, BATTERY	1
19	063082-000	J-BOLT	2
20	064464-000	CABLE RETAINER	1
21	063386-000	CHARGER SPACER	1

Illustrated Parts Breakdown

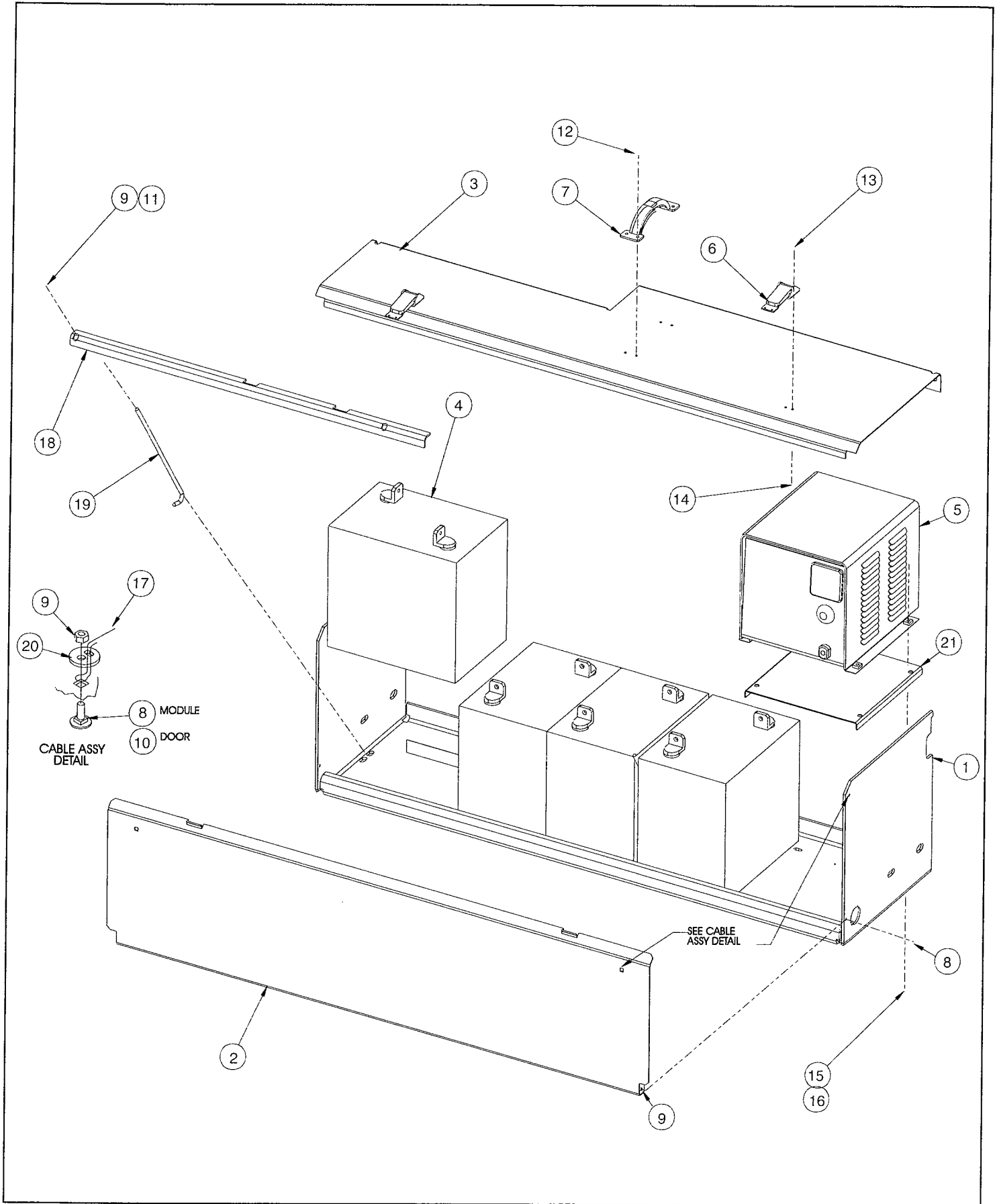

CONTROL VALVE ASSEMBLY

SL20

101120-020

ITEM	PART	DESCRIPTION	QTY.
1	100020-039	CONTROL VALVE BLOCK	1
2	011934-001	FITTING ELBOW 90° 4MB - 4MJ	2
3	011934-004	FITTING ELBOW 90° 6MB - 6MJ	3
4	011941-001	FITTING STRAIGHT 4MB - 4MJ	1
5	015736-001	FITTING ELBOW90°4MB - 4MJ(EXTENDED)	2
6	015736-002	FITTING ELBOW90°6MB - 6MJ(EXTENDED)	1
7	011937-001	FITTING ELBOW90° 4FJX - 4MJ	1
8	011934-007	FITTING ELBOW 90° 8MB-6MJ	1
9	101120-022	RELIEF VALVE, STEERING (1000 PSI)	1
10	101120-023	RELIEF VALVE, MAIN (2800 PSI)	1
11	101120-024	2 POS - 4 WAY SOLENOID W/ COIL (LIFT)	1
12	101120-031	COIL, 10 SERIES 20 VOLT DC	REF
13	101120-025	3 POS - 4 WAY SOLENOID W/COILS (STEERING)	1
14	101120-026	COUNTERBALANCE VALVE	1
15	101120-027	PROPORTIONAL VALVE W/ COIL	1
16	101120-032	COIL, 10 SERIES 24 VOLT DC	REF
17	101120-028	FLOW DIVIDER VALVE (1.0 GPM)	1
18	101120-029	2 POS POPPET VALVE W/ COIL (POTHOLE PROTECTION)	1
19	101120-033	COIL, 8 SERIES 20 VOLT DC	REF
20	063664-009	ORIFICE (Ø .052)HYDROFORCE 7051-052	1
21	020021-004	FITTING PLUG 4MB	2
22	101120-007	CHECK VALVE	1
23	101120-030	3 POS - 4 WAY SOLENOID W/COILS (DRIVE)	1

Illustrated Parts Breakdown

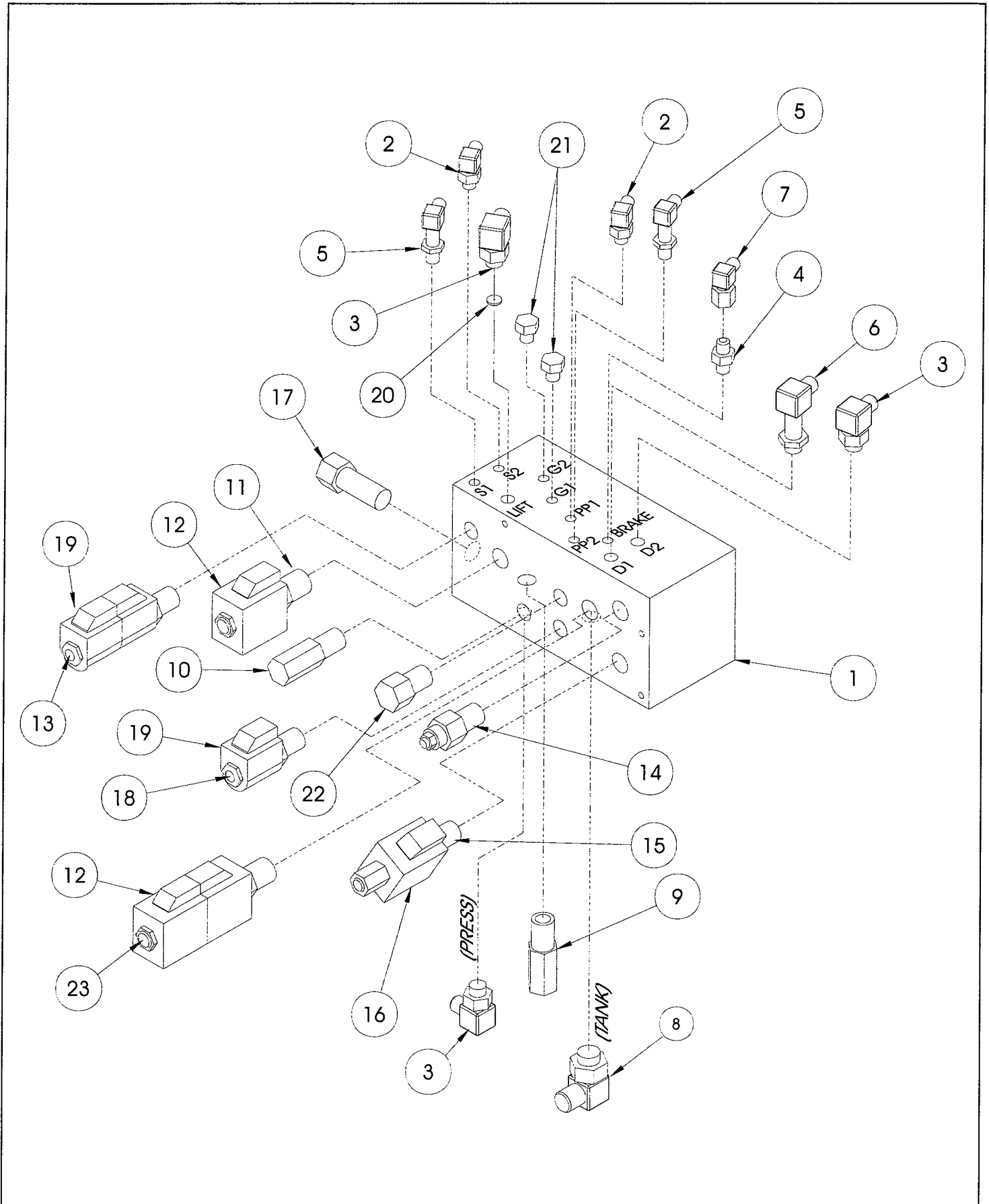

CONTROLLER ASSEMBLY TOGGLE SL20 101155-001

ITEM	PART	DESCRIPTION	QTY.
1	101231-000	COVER, CONTROLLER	1
2	012798-000	SWITCH, TOGGLE	2
3	101114-000	ENCLOSURE, CONTROLLER	1
4	066805-003	SWITCH, SELECTOR	1
5	101232-000	LABEL, CONTROLLER	1
6	066805-011	CONTACT BLOCK N.C.	3
7	066805-006	SWITCH, PUSHBUTTON	1
9	101158-099	O-RING SEAL 3/32	2 FT
10	101231-000	COVER, TOGGLE CONTROLLER	1
11	011709-004	SCREW, #10-24 UNC RD HD MACH X 1/2	4

ITEM	PART	DESCRIPTION	QTY.
12	011238-002	LOCKWASHER, #10 SPLIT	4
13	029453-099	WIRE, ORANGE 16 AWG	14"
15	029620-002	CONN, BUTT 16-14 GA INSL	1
22	029610-012	TERMINAL, RING 16/14 #8	6
23	029610-002	TERMINAL, FORK 16-14 GA #8	6
24	029925-010	STRAIN RELIEF	1
25	029939-003	LOCKUNT	1
29	029496-099	CABLE, 16 AWG 2 COND	4 FT
30	063906-000	SWITCH, FOOT	1

CONTROLLER ASSEMBLY SL20 DRAWING 1 OF 2

TOGGLE CONFIGURATION

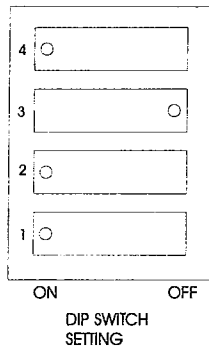

DIP SWITCH LOCATED IN THE
CONTROL RELAY IN THE
LOWER CONTROLS ASSEMBLY

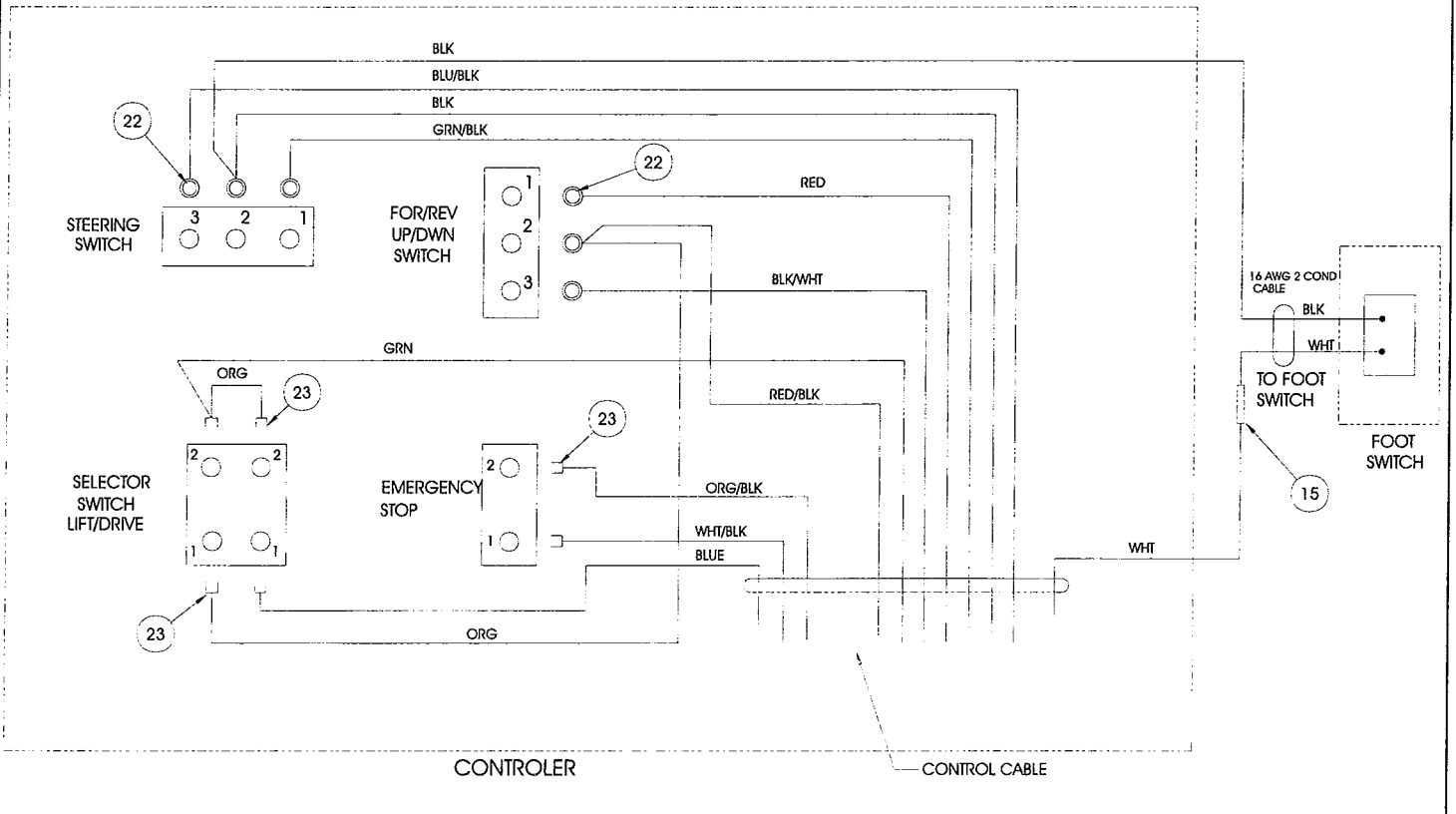

Illustrated Parts Breakdown

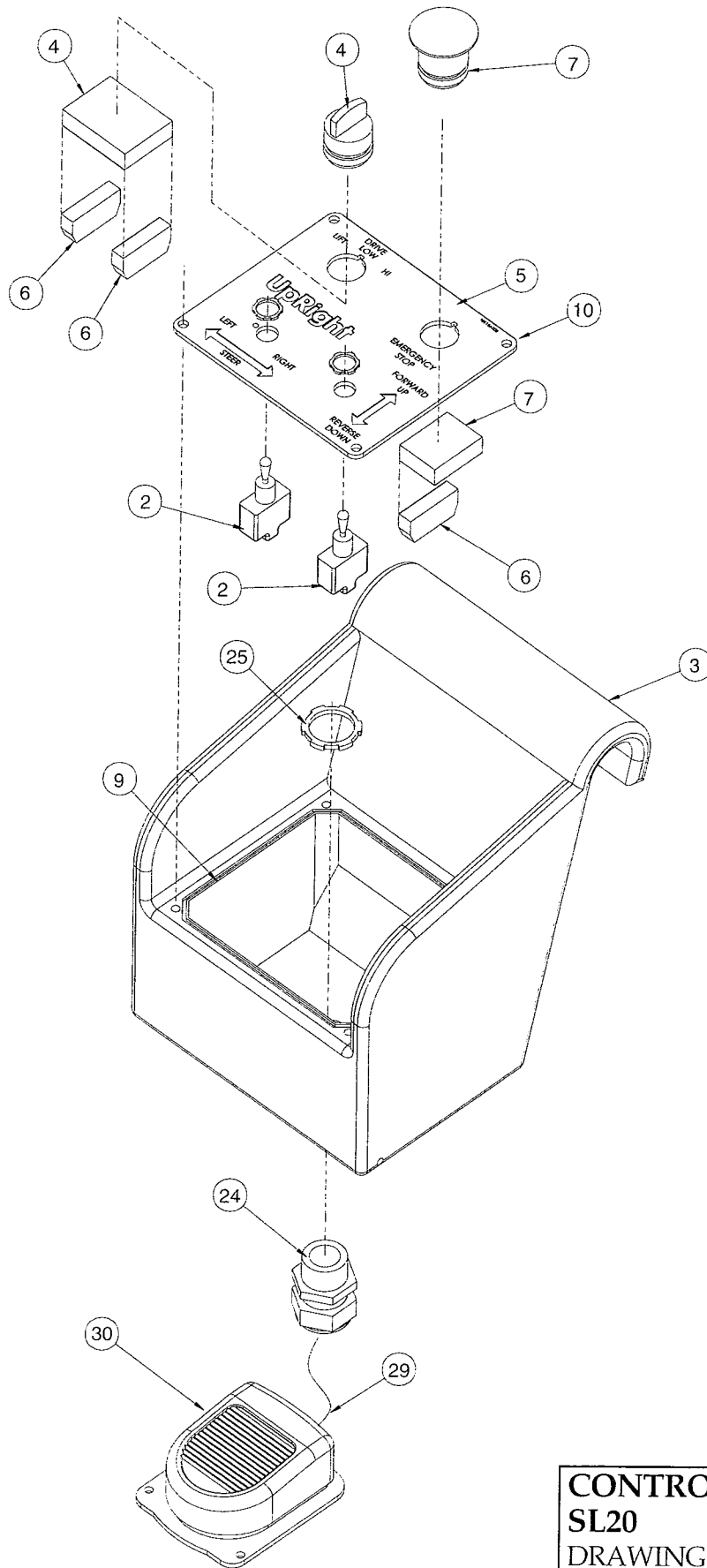

CONTROLLER ASSEMBLY
SL20
DRAWING 2 OF 2

PLATFORM ASSEMBLY

SL20

101007-000

ITEM	PART	DESCRIPTION	QTY.
1	101006-000	PLATFORM WELDMENT	1
2	101101-000	SIDE RAIL WELDMENT	2
3	024611-033	DECK, PLYWOOD	1
4	026554-004	RIVET, 1/4 DIA X .501-.625 GRIP	4
5	067805-099	EDGE TRIM, 1/4 - 1/2	FT.34
6	101164-000	END RAIL WELDMENT	1
7	101168-000	KICKRAIL WELDMENT, BOLT ON	1

ITEM	PART	DESCRIPTION	QTY.
8	101170-000	FRONT-END GUARDRAIL WELDMENT	1
9	101115-000	LATCH, GATE	4
10	011254-018	SCREW, 3/8-16 UNC HEX HD CAP X 2 1/4	20
11	011248-006	LOCKNUT, 3/8-16 UNC HEX	28
12	011252-004	SCREW, 1/4-20 UNC HEX HD CAP X 1/2	6
13	015748-002	REPAIR LINK	1
14	063133-003	CHAIN ASSEMBLY	1
15	011254-008	SCREW, 3/8-16 UNC HEX HD CAP X 1	4

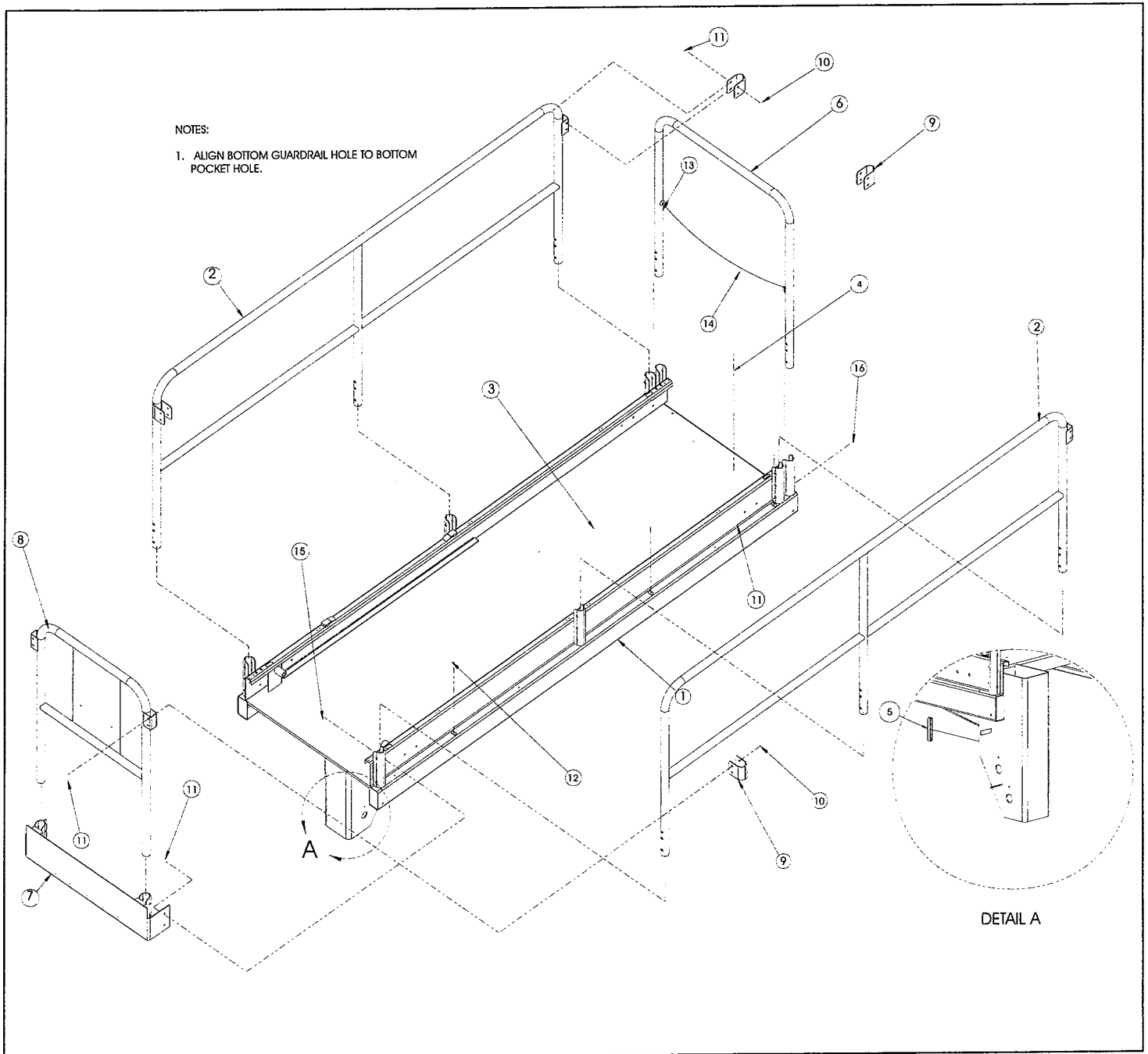

Illustrated Parts Breakdown

HOSE KIT INSTALLATION

SL20

101179-001

ITEM	PART	DESCRIPTION	QTY.
1	060861-107	HOSE ASSEMBLY, 3/8 DIA 6FJX-6FJX X 206	1
2	060861-210	HOSE ASSEMBLY, 3/8 DIA 6FJX-6FJX X 210	1
3	065234-028	HOSE ASSEMBLY, 1/4 DIA 4FJX-4FJX X 28	2
5	065234-021	HOSE ASSEMBLY, 1/4 DIA 4FJX-4FJX X 21	2
6	065234-041	HOSE ASSEMBLY, 1/4 DIA 4FJX-4FJX X 41	1
7	060861-049	HOSE ASSEMBLY, 3/8 DIA 6FJX-6FJX X 28	1

ITEM	PART	DESCRIPTION	QTY.
8	060861-025	HOSE ASSEMBLY, 3/8 DIA 6FJX-6FJX X 50	2
9	065234-046	HOSE ASSEMBLY, 1/4 DIA 4FJX-4FJX X 46	2
10	020032-001	FITTING, TEE 4MJ-4MJ-4MJ	REF
12	060861-022	HOSE ASSEMBLY, 3/8 DIA 6FJX-6FJX X 14	1
13	060861-021	HOSE ASSEMBLY, 3/8 DIA 6FJX-6FJX X 12	1
14	061789-012	HOSE ASSEMBLY, 3/4 DIA 12FJX-12MP X 13	1

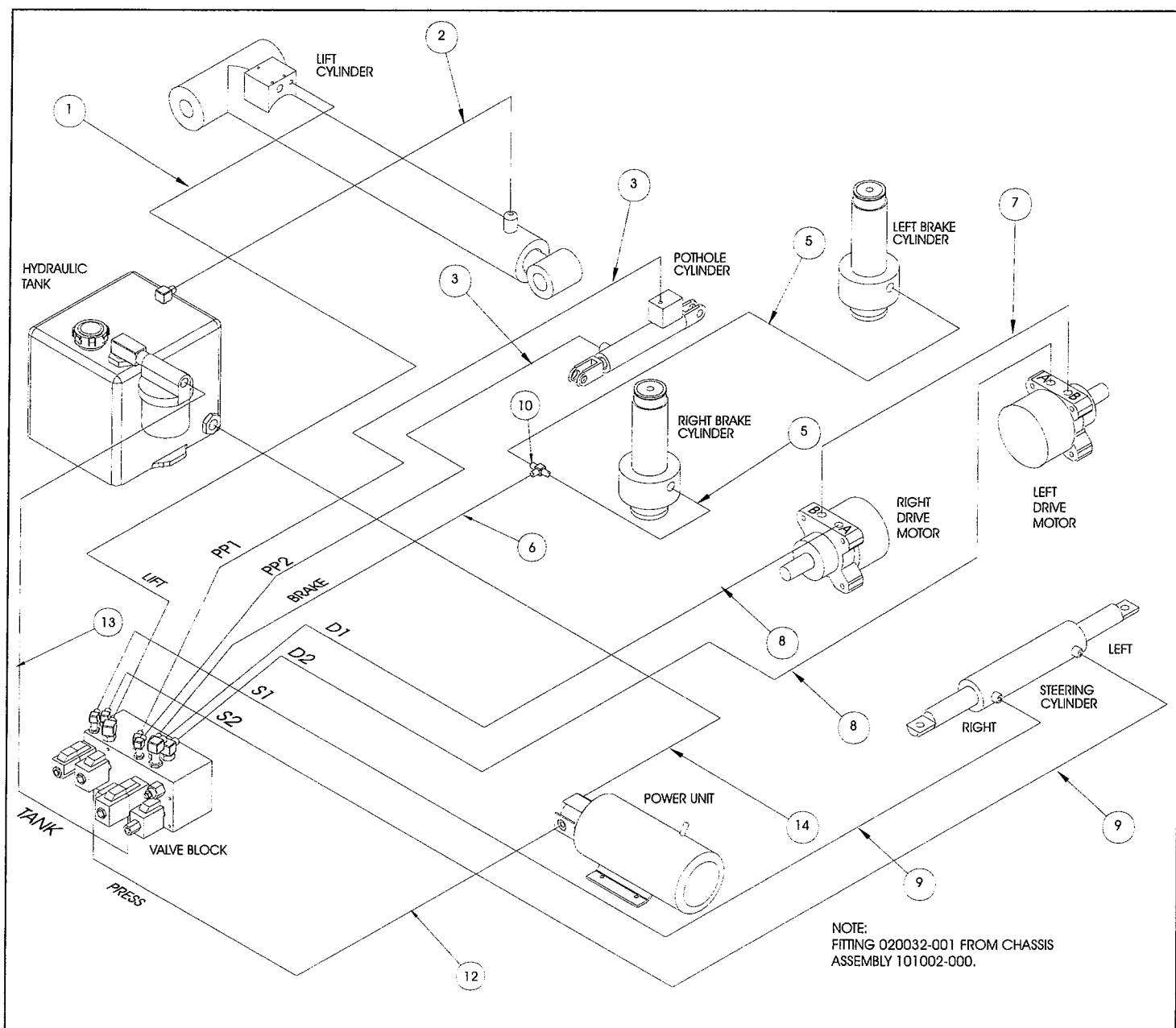

LOWER CONTROLS ASSEMBLY

SL20

101154-001

ITEM	PART	DESCRIPTION	QTY.
1	101147-000	LOWER CONTROLS WELDMENT	1
2	029868-007	CIRCUIT BREAKER	1
3	101221-000	SWITCH, KEY	1
4	012798-000	SWITCH, TOGGLE	1
5	101129-001	CONTROL BOX 24VDC	1
6	066807-001	ALARM	1
7	010148-001	FUSE, 175 AMP	1
8	010149-000	FUSE BLOCK	1

ITEM	PART	DESCRIPTION	QTY.
9	066805-006	SWITCH, PUSH BUTTON	1
10	066805-011	CONTACT BLOCK, N.C.	1
11	011248-003	LOCKNUT, #10-24 UNC HEX	2
12	014996-003	WASHER, #10 DIA FLAT SAE	2
13	066695-008	SCREW, #10-24 UNC FLAT HD	2
14	011252-006	SCREW, 1/4-20 UNC HEX HD CAP X 3/4	2
15	011248-004	LOCKNUT, 1/4-20 UNC HEX	2
16	066805-010	CONTACT BLOCK, N.O.	2
17	101228-000	HARNESS, LOWER CONTROLS	1

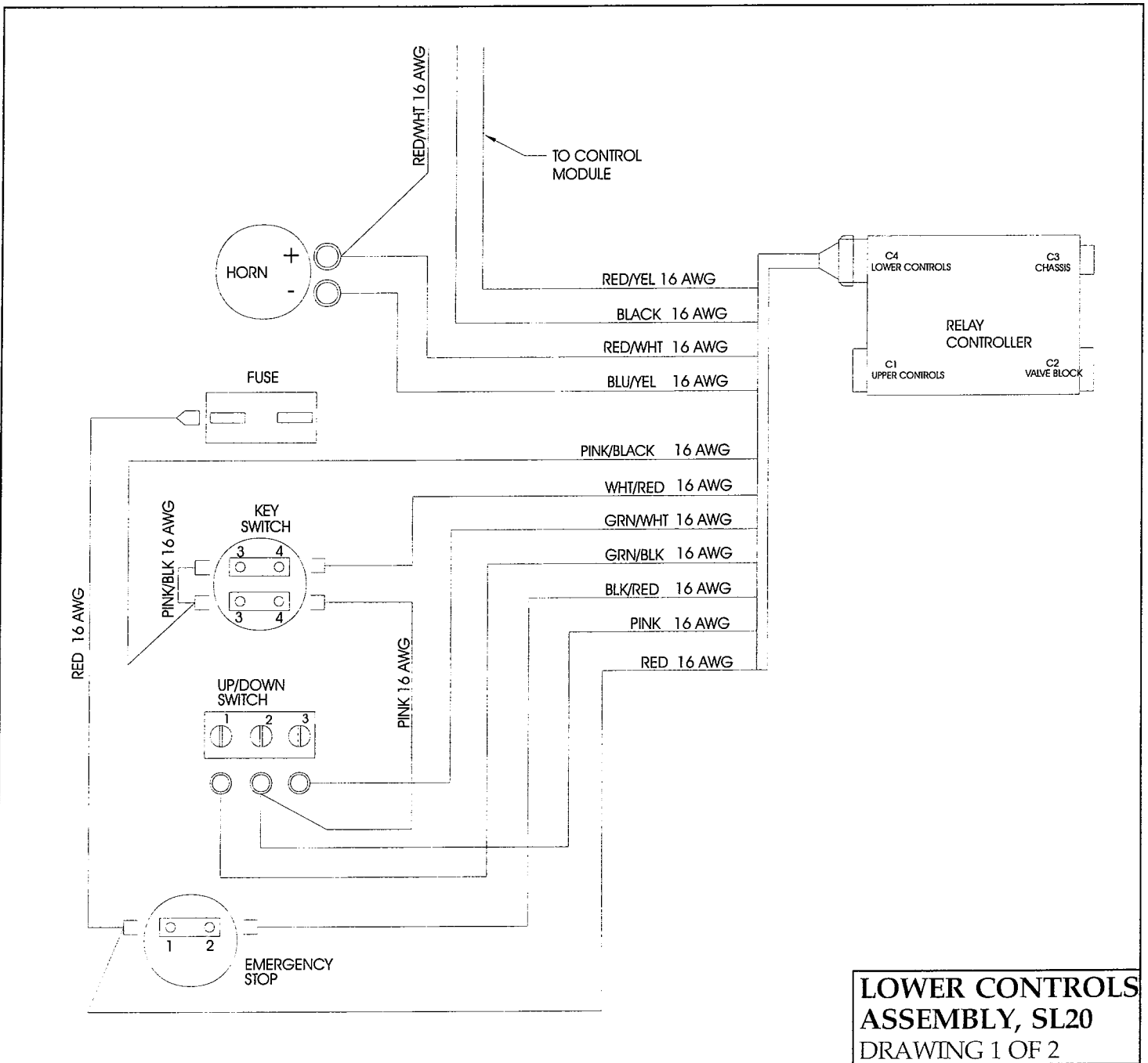

Illustrated Parts Breakdown

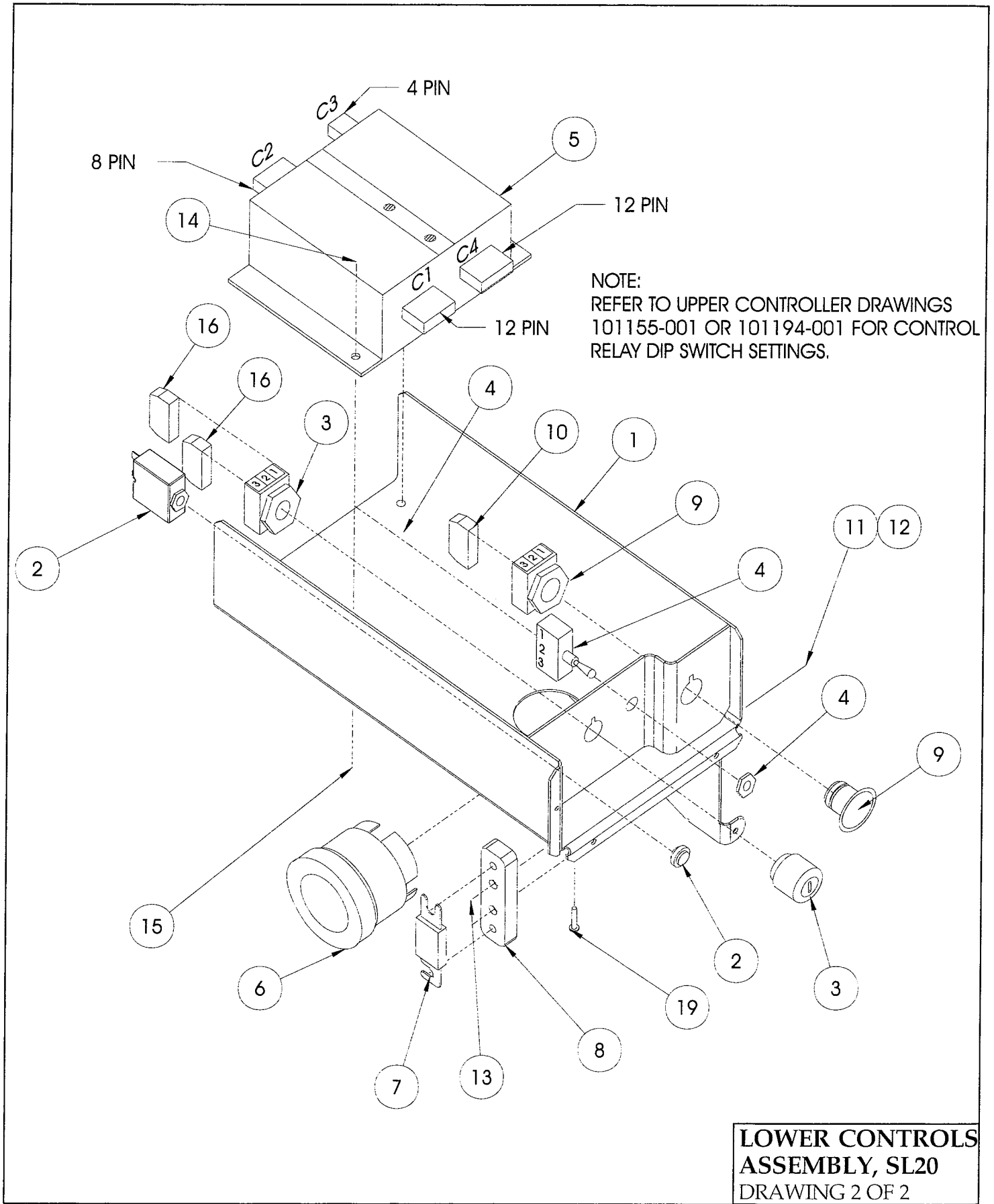

**LOWER CONTROLS
ASSEMBLY, SL20
DRAWING 2 OF 2**

CONTROL CABLE ASSEMBLY

SL20

101021-000

ITEM	PART	DESCRIPTION	QTY.
1	010131-099	CABLE, 16 AWG, 12 COND	37 FT
2	068762-001	SOCKET, PLUG	12
3	068760-000	068760-000 PLUG	1
4	068908-000	BOOT, RECEPTICAL	2
5	068761-001	Locking Wedge	1

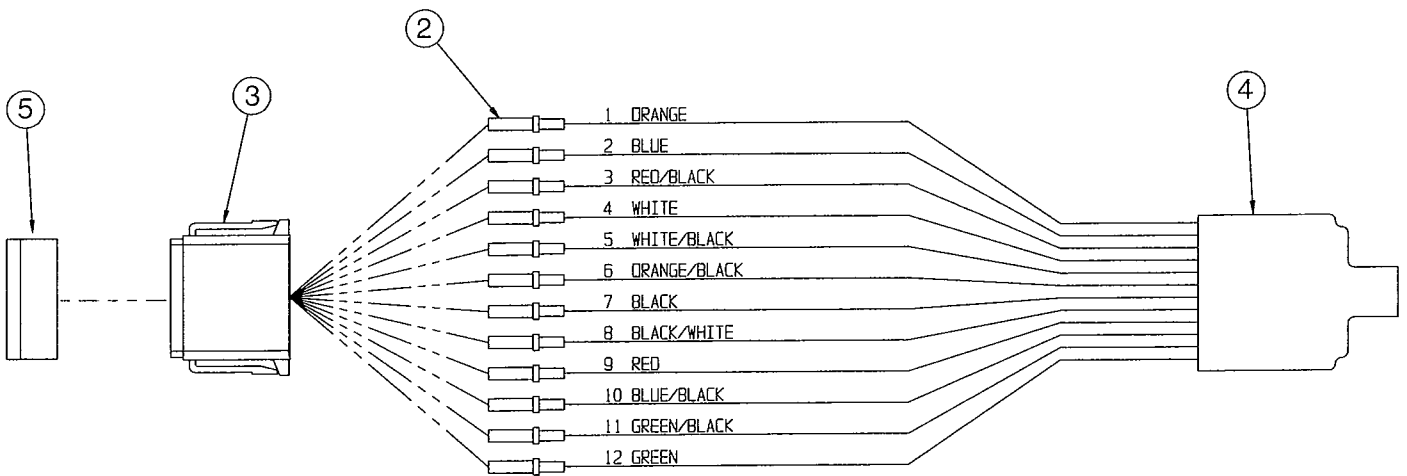

Illustrated Parts Breakdown

HYDRAULIC TANK ASSEMBLY

SL20

101152-000

ITEM	PART	DESCRIPTION	QTY.
1	101056-000	TANK, HYDRAULIC	1
2	021305-006	PLUG, MAGNETIC	1
3	061818-000	STRAINER, SUCTION	1
4	011940-006	FITTING, ELBOW	1
5	011917-012	FITTING, ELBOW	1
6	011923-012	FITTING, REDUCER	1
7	012467-004	NIPPLE 3/4 NPT X 2 LG.	1
8	068982-001	CAP, HYDRAULIC FLUID	1

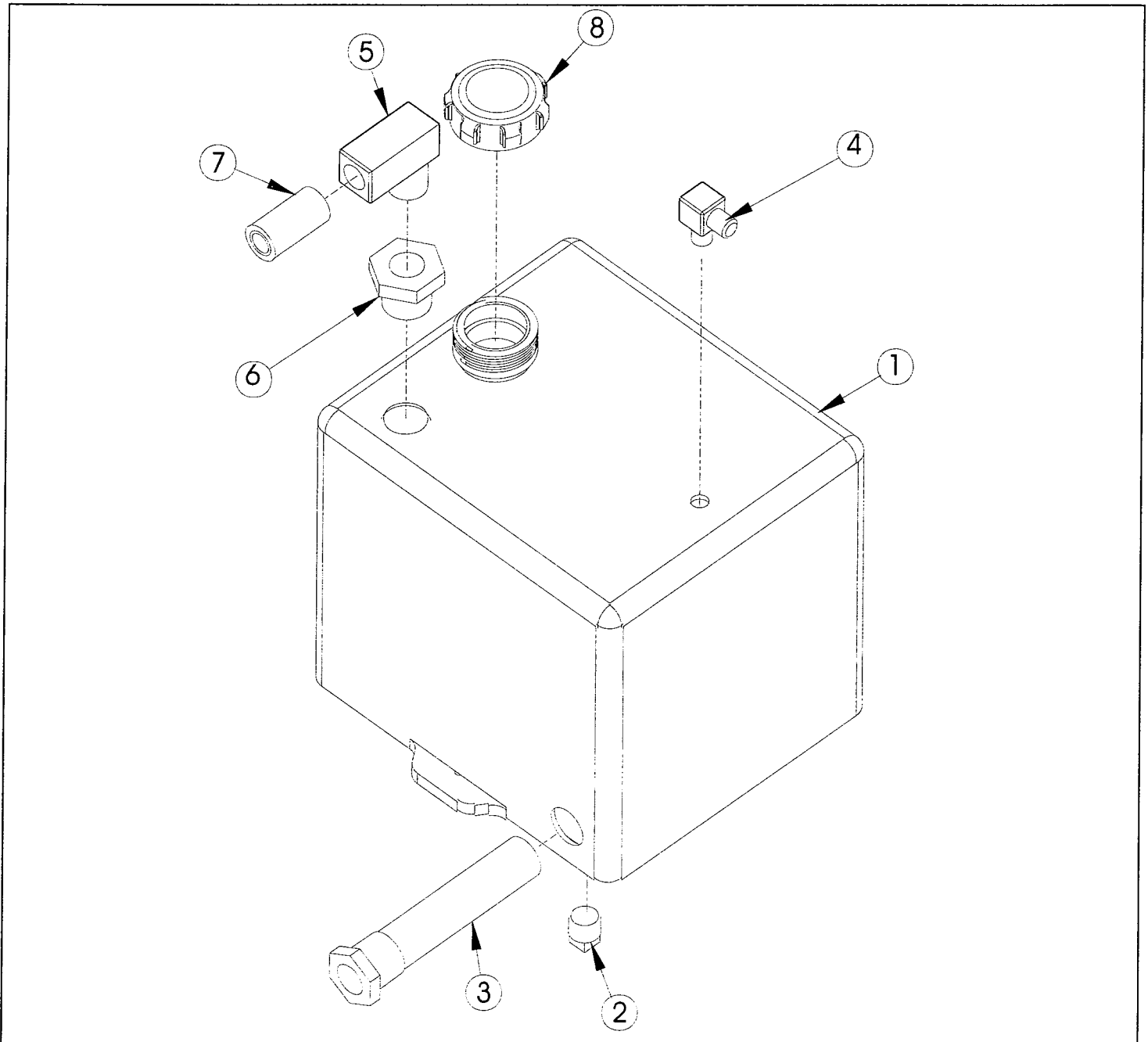

Illustrated Parts Breakdown

LABEL KIT INSTALLATION

SL20

101009-000

ITEM	PART	DESCRIPTION	QTY.
1	005221-000	LABEL, BATTERY FLUID	1
2	066557-014	LABEL, MAX LOAD 750 LBS	2
3	014222-003-099	LABEL, FORK LIFT HERE	2
4	065368-000	TACK	4
5	061205-000	NAME PLATE	1
6	066568-000	LABEL, LOWER PLATFORM	1
7	066552-000	LABEL, DANGER HYDROGEN GAS	1
8	061220-001	LABEL, ANSI REQ.	1
9	010076-001	LABEL, ATTENTION	1
10	027966-007	SAFETY WALK, 3 X 6	4
11	066559-000	LABEL, CONTROLS	1
12	066558-000	LABEL, EMERGENCY LOWERING	1
13	066555-000	LABEL, CAUTION RELIEF VALVE	1
14	062562-001	LABEL, DANGER BATTERIES	1
15	061683-013	LABEL, UP-RIGHT	6
16	066554-000	LABEL, BEFORE OPERATING	1

ITEM	PART	DESCRIPTION	QTY.
17	101222-000	LABEL, PROPORTIONAL CNTRLR OPTIN	1
18	060577-000	ANSI MANUAL	1
19	101198-000	USER MANUAL	1
20	066553-004	LABEL, WARNING PINCH POINT	2
21	101232-000	LABEL, CONTROLLER (TOGGLE)	1
22	064444-000	LABEL, USA	4
23	061684-028	LABEL, SL20	4
24	066550-006	LABEL, DANGER	1
25	066556-001	LABEL, WARNING CRUSHING	4
26	011252-006	SCREW, 1/4-20 UNC HEX HD CAP X 3/4	2
27	011248-004	LOCKNUT, 1/4-20 UNC HEX	2
28	010076-000	MANUAL CASE	1
29	066553-001	LABEL, WARNING PINCH POINT	2
30	065929-099	TAPE, DOUBLE SIDED	2 FT
31	066520-099	TAPE, UHMW	2 FT
32	101203-000	LABEL, FILL LINE	1

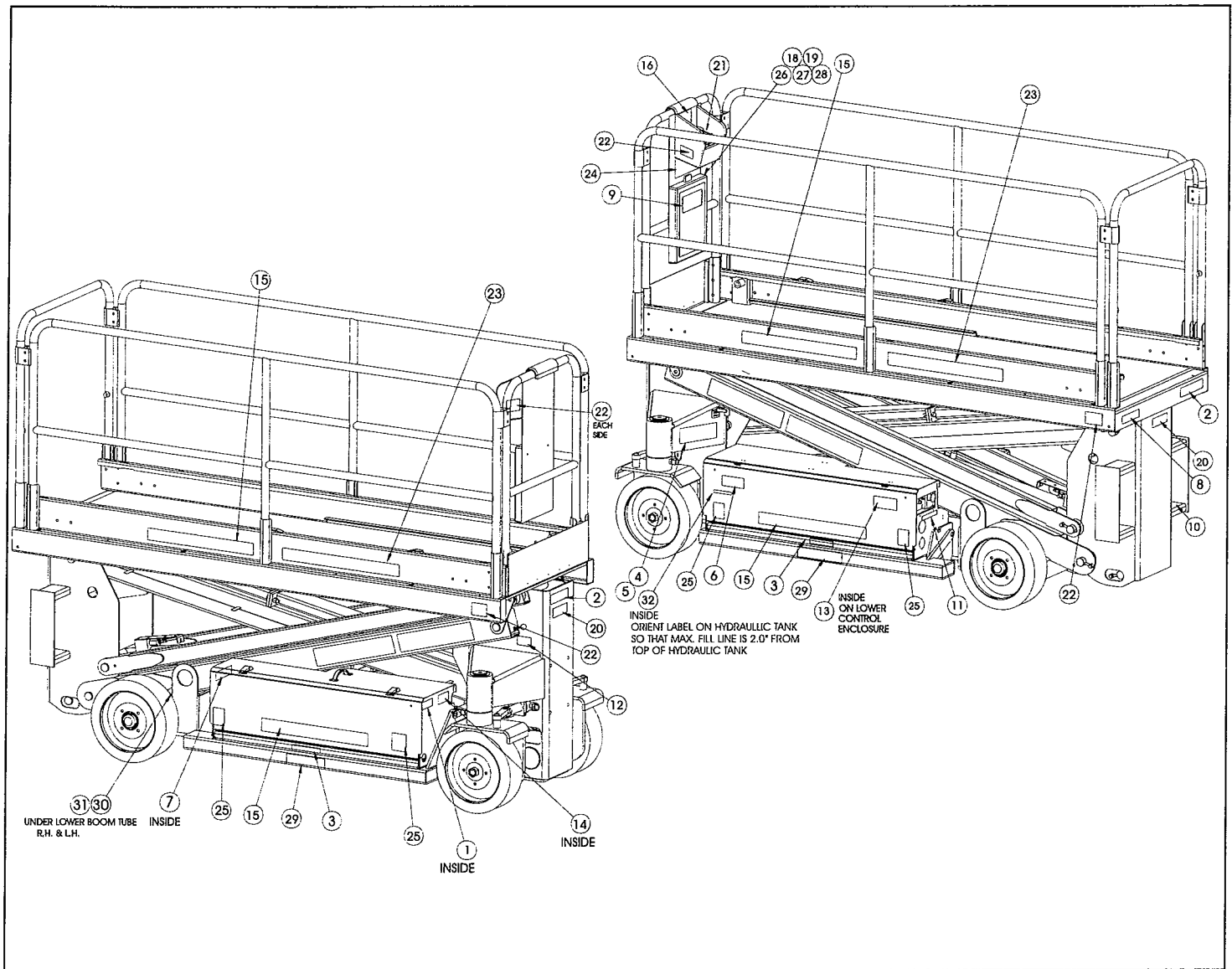

Illustrated Parts Breakdown

3 FT. ROLL-OUT DECK EXTENSION OPTION, SL20 101008-000

ITEM	PART	DESCRIPTION	QTY.
1	101130-000	DECK EXTENTION WELDMENT	1
2	101132-000	MAIN GUARDRAIL WELDMENT	1
3	101007-000	PLATFROM ASSEMBLY	REF
4	066256-000	ROLLER MOUNT WELDMENT	2
5	101106-000	ROLLER	4
6	066198-000	WEAR PAD	1
7	066193-000	STOP	4
8	066170-000	WEAR PAD	4
9	066407-000	BRACKET	2
10	026553-004	RIVET, 3/16 DIA X 3/8 GRIP	2
11	026553-008	RIVET, 3/16 DIA X .50 GRIP	16
12	011254-014	SCREW, 3/8-16 UNC HEX HD CAP X 1 3/4	2

ITEM	PART	DESCRIPTION	QTY.
13	011252-006	SCREW, 1/4-20 UNC HEX HD CAP X 3/4	4
14	066171-003	BOLT, 3/8-16 UNC TAP X 2 1/4	4
15	011240-004	WASHER, 1/4 DIA STD FLAT	4
16	011238-006	WASHER, 3/8 DIA SPLIT LOCK	8
17	011248-004	LOCKNUT, 1/4-20 UNC HEX	4
19	011254-012	SCREW, 3/8-16 UNC HEX HD CAP X 1 1/2	6
20	066410-000	DECK STOP WELDMENT	1
21	003570-001	RETAINING PIN	1
22	015924-020	WASHER, 2" FENDER	1
23	027966-006	SAFETY WALK, 6 X 12	2
24	066557-008	LABEL, MAX LOAD 250 LBS	1
25	027966-005	SAFETY WALK, 6 X 24	4

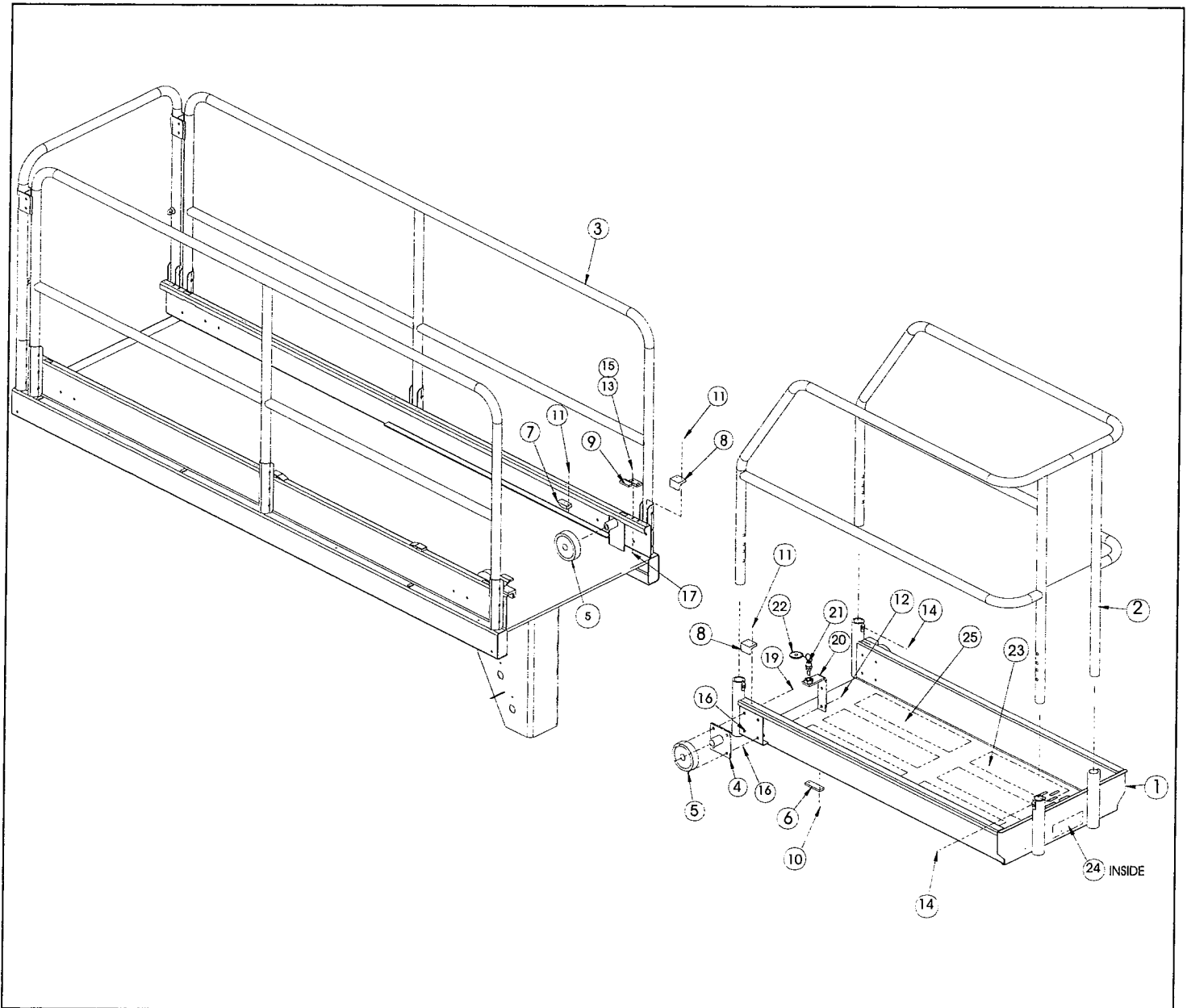

**GATE INTERLOCK
SL20**
101249-001

ITEM	PART	DESCRIPTION	QTY.
1	065373-005	MAGNET, SWITCH	1
2	065373-006	SWITCH	1
3	065519-000	SWITCH PAD	1
4	065785-000	DOOR ANGLE	1
5	026551-005	RIVET, POP, 1/8 X 1/4 GRIP	6
6	029496-099	CABLE, 16 AWG, 2 COND	34 FT
7	063951-002	RELAY 24 V	1
8	014914-001	CONN, MALE PUSH 16-14 X .25	4
9	011715-006	SCREW, #6-32 UNC HEX HD MACH X 3/4	2
10	011250-001	NUT, #6-32 UNC HEX	2
11	029620-002	CONNECTOR, BUTT	2
12	029610-002	CONNECTOR, FORK 16-14 GA. #8	1
13	011240-001	WASHER	2

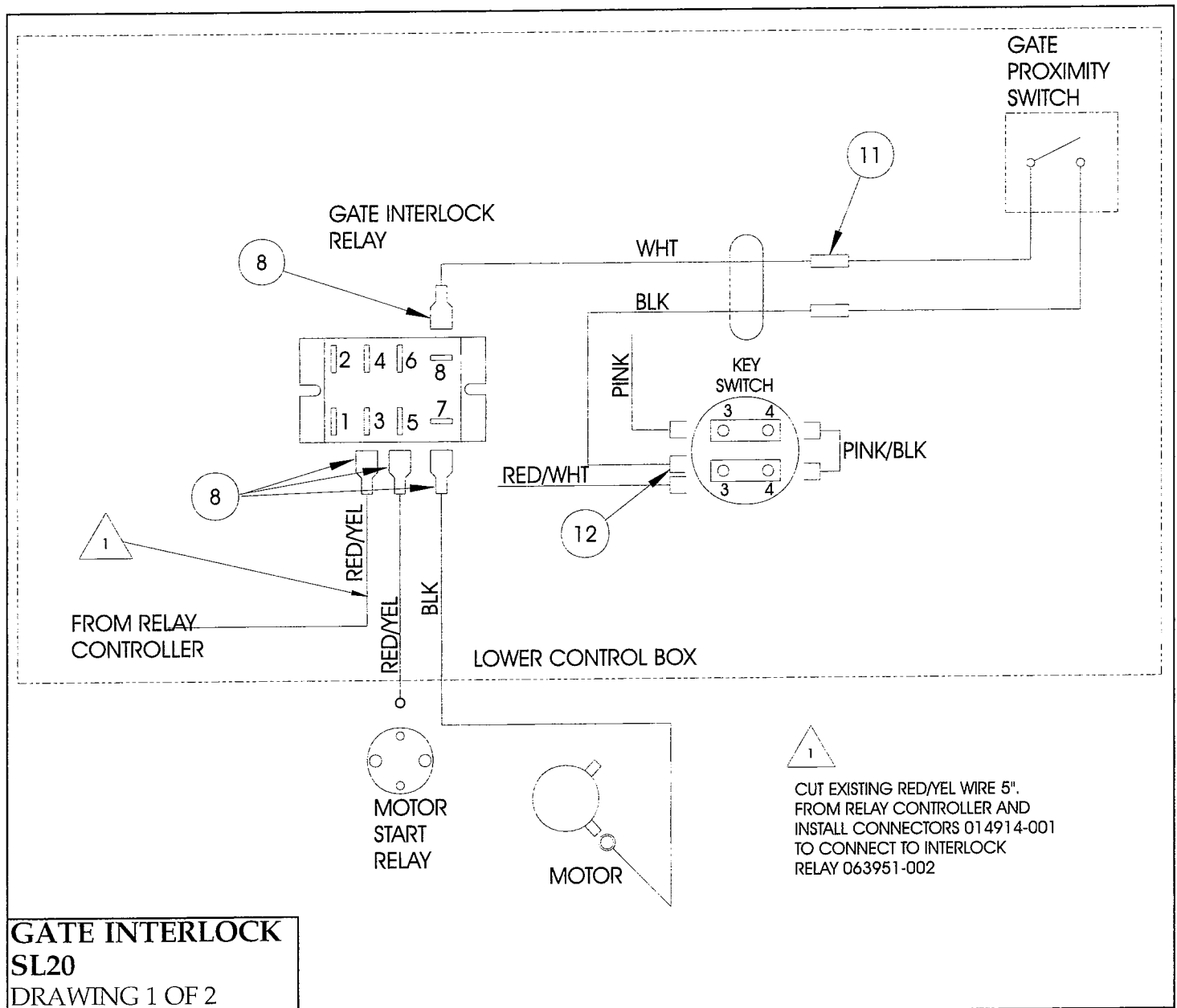

Illustrated Parts Breakdown

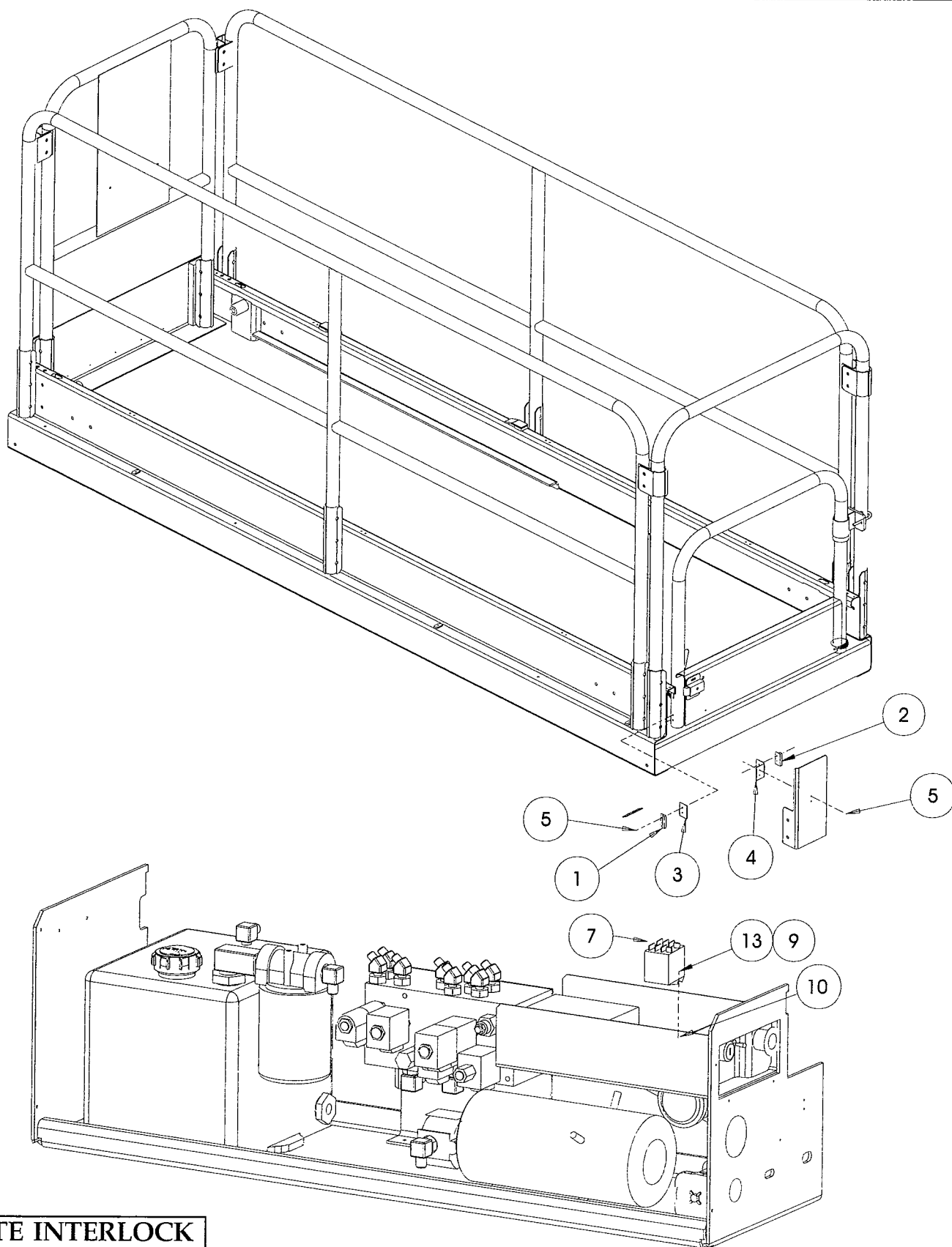

GATE INTERLOCK
SL20
DRAWING 2 OF 2

POWER TO PLATFORM OPTION
SL20
101196-000

ITEM	PART	DESCRIPTION	QTY.
1	101155-000	CONTROLLER ASSEMBLY	REF
2	101005-001	CONTROL MODULE ASSEMBLY	REF
3	101185-000	BRACKET, POWER TO PLATFORM	1
4	008942-001	OUTLET, AC	1
5	029961-002	OUTLET, MALE	1
6	029961-001	BOOT	2
7	011715-004	SCREW, #6-32 UNC RD HD MACH X 1/2	2
8	011715-006	SCREW, #6-32 UNC RD HD MACH X 3/4	2
9	011248-047	LOCKNUT, #6-23 UNC HEX	4
10	029495-099	WIRE, 14 GA 3 COND	37'
11	011252-008	SCREW, 1/4-20 UNC HEX HD CAP X 1	2
12	011248-004	LOCKNUT, 1/4-20 UNC HEX	2
13	011240-004	WASHER, 1/4 DIA STD FLAT	4

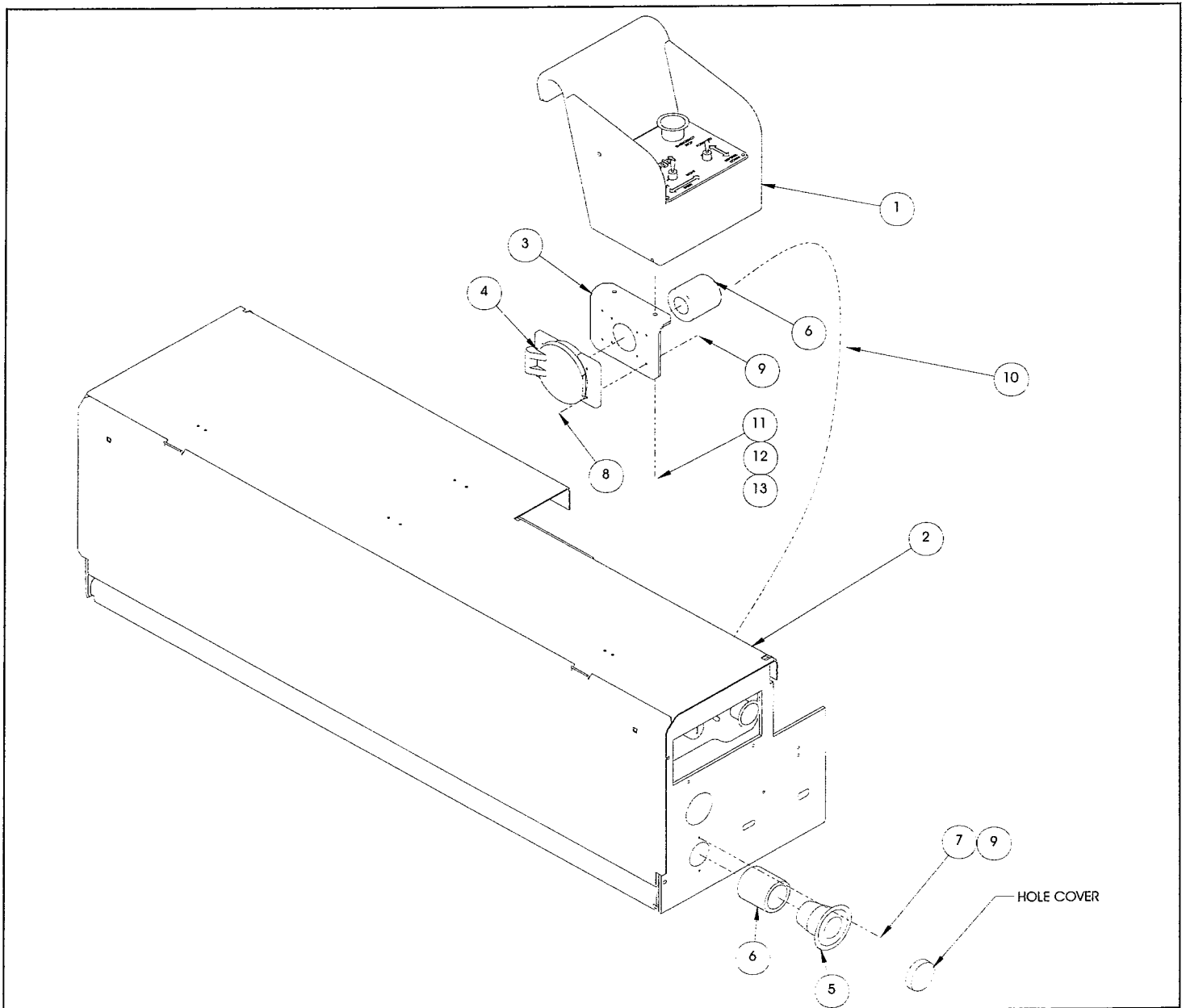

Illustrated Parts Breakdown

AIR TO PLATFORM OPTION

SL20

101197-000

ITEM	PART	DESCRIPTION	QTY.
1	063191-000	BRACKET WELDMENT	2
2	012728-000	COUPLING	1
3	012729-003	COUPLING	1
4	101155-000	TOGGLE CONTROLLER ASSEMBLY	REF
5	101005-001	CONTROL MODULE ASSEMBLY	REF
6	064274-002	HOSE FITTING	2
7	011917-007	FITTING, ELBOW	1
8	011249-003	LOCKNUT, #10-32 UNF HEX	4
9	011826-008	SCREW, #10-32 UNF RND HD MACH X 1	4
10	015770-099	HOSE, 3/8 AIR	50 FT

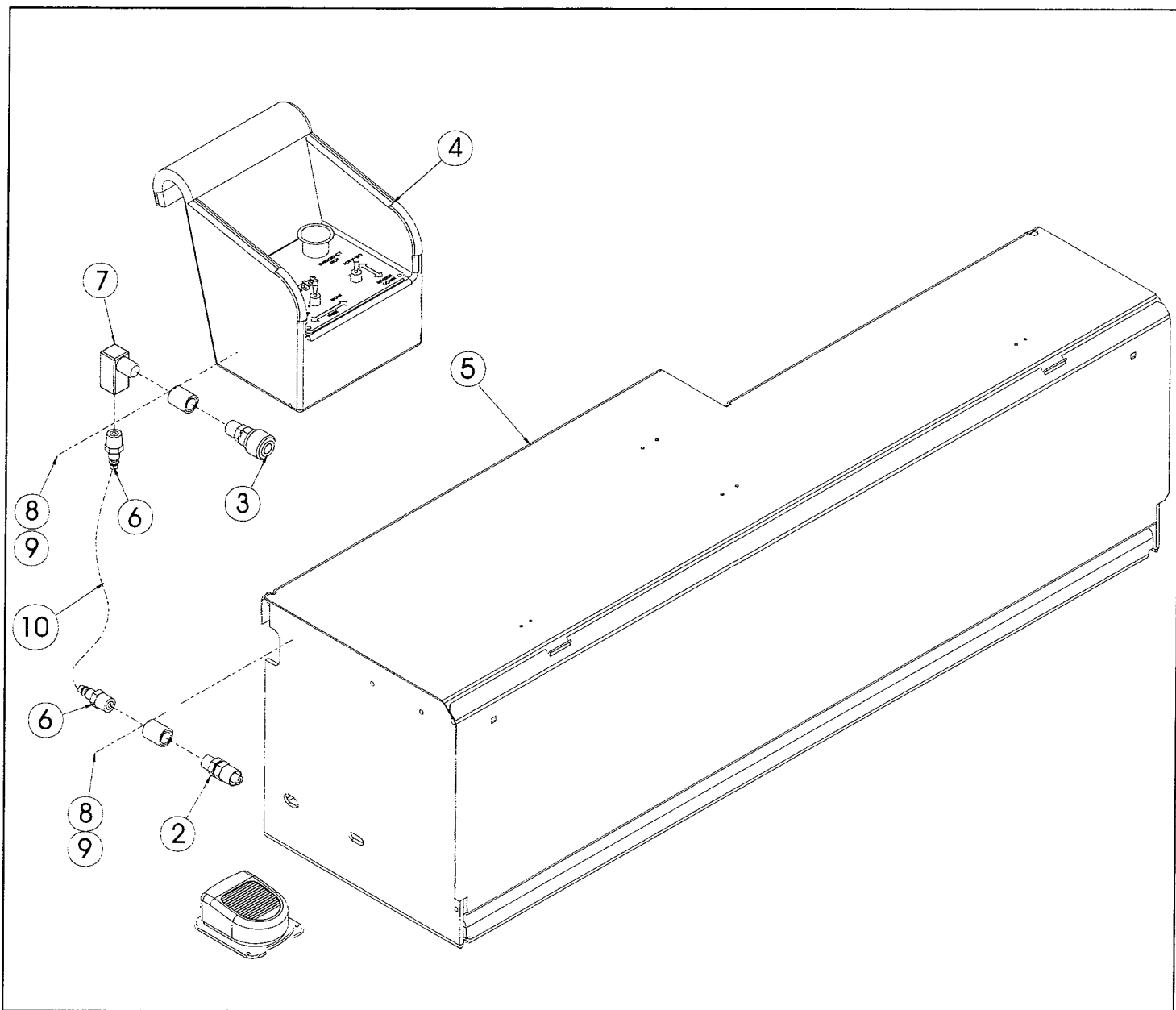

HORN OPTION

SL20

101190-000

ITEM	PART	DESCRIPTION	QTY.
1	101005-001	CONTROL MODULE ASSEMBLY	REF
2	066807-002	HORN, 24 VDC	1
3	063917-000	SWITCH, PUSH BUTTON	1
5	029496-099	WIRE, 2 COND 16GA	43FT
6	029601-013	CONNECTOR, RING TERMINAL	4
7	029453-099	WIRE, 16 AWG ORANGE	2FT
8	029452-099	WIRE, 16 AWG BLACK	1FT

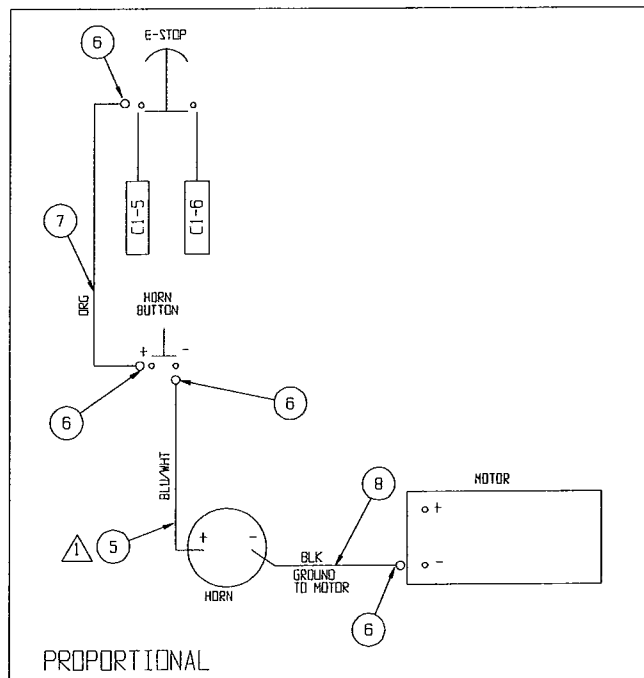

NOTES:
 ⚠️ REQUIRED ON UNITS WITH PROPORTIONAL (JOYSTICK) CONTROLS HAVING 12 CONDUCTOR CONTROL CABLE.

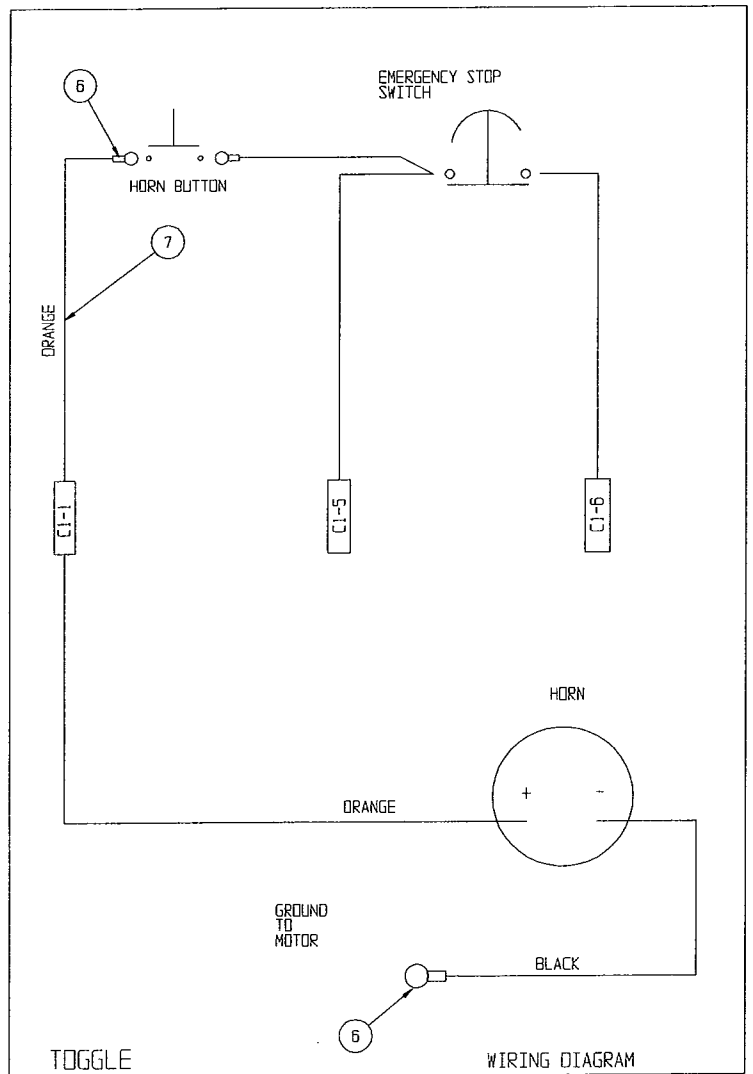

(12V OR 24V)

Illustrated Parts Breakdown

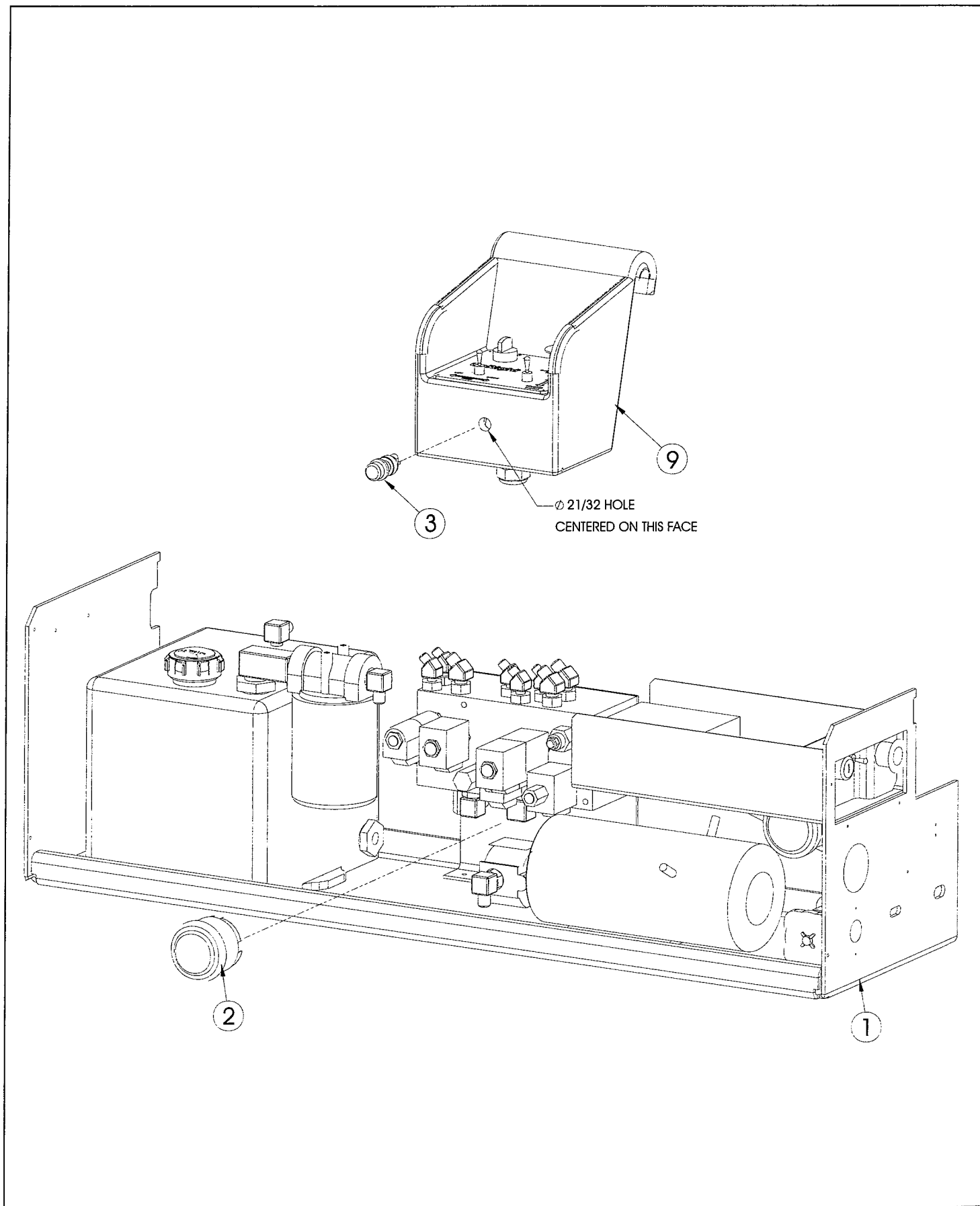

PROPORTIONAL CONTROLLER OPTION, SL20

101194-001

ITEM	PART	DESCRIPTION	QTY.
1	101188-000	BOX, PROPORTIONAL CONTROLLER	1
2	101223-000	COVER, PROPORTIONAL CONTROLLER	1
3	066805-002	SWITCH, SELECTOR	1
4	066805-006	SWITCH, PUSH BUTTON	1
5	066805-011	CONTACT	1
6	066805-012	CONTACT	1
7	101205-000	CONTROLLER PROPORTIONAL 24VDC	1
8	101222-000	LABEL, PROPORTIONAL CONTROL	1
9	101158-099	O-RING 3/32	1
10	029610-002	CONN FORK TERM 16-14 GA. #8	8
11	011709-004	SCREW#10-24 UNC RD HDMACH X 1/2LG	4
12	011238-022	LOCKWASHER, #10 SPLIT	4

ITEM	PART	DESCRIPTION	QTY.
13	066805-010	CONTACT, N.O.	1
16	029925-010	CONN, CABLE	1
17	029939-003	LOCKNUT, 3/4 NUT CONNECTOR	1
18	101181-002	ELECTRICAL SCHEMATIC	REF
19	065746-000	CONTROLLER GUIDE	1
20	011252-006	SCREW, 1/4-20 UNC HEX HD CAP X 3/4	2
21	011248-004	LOCKNUT, 1/4-20 UNC HEX	2
22	063956-003	CONN, 12 PIN	1
23	063956-010	CONN, PIN MALE	9
26	029478-099	WIRE, 16 AWG, RED/BLK	FT2
27	029455-099	WIRE, 16 AWG, BROWN	FT1.5
28	029452-099	WIRE, 16 AWG, BLACK	FT.5

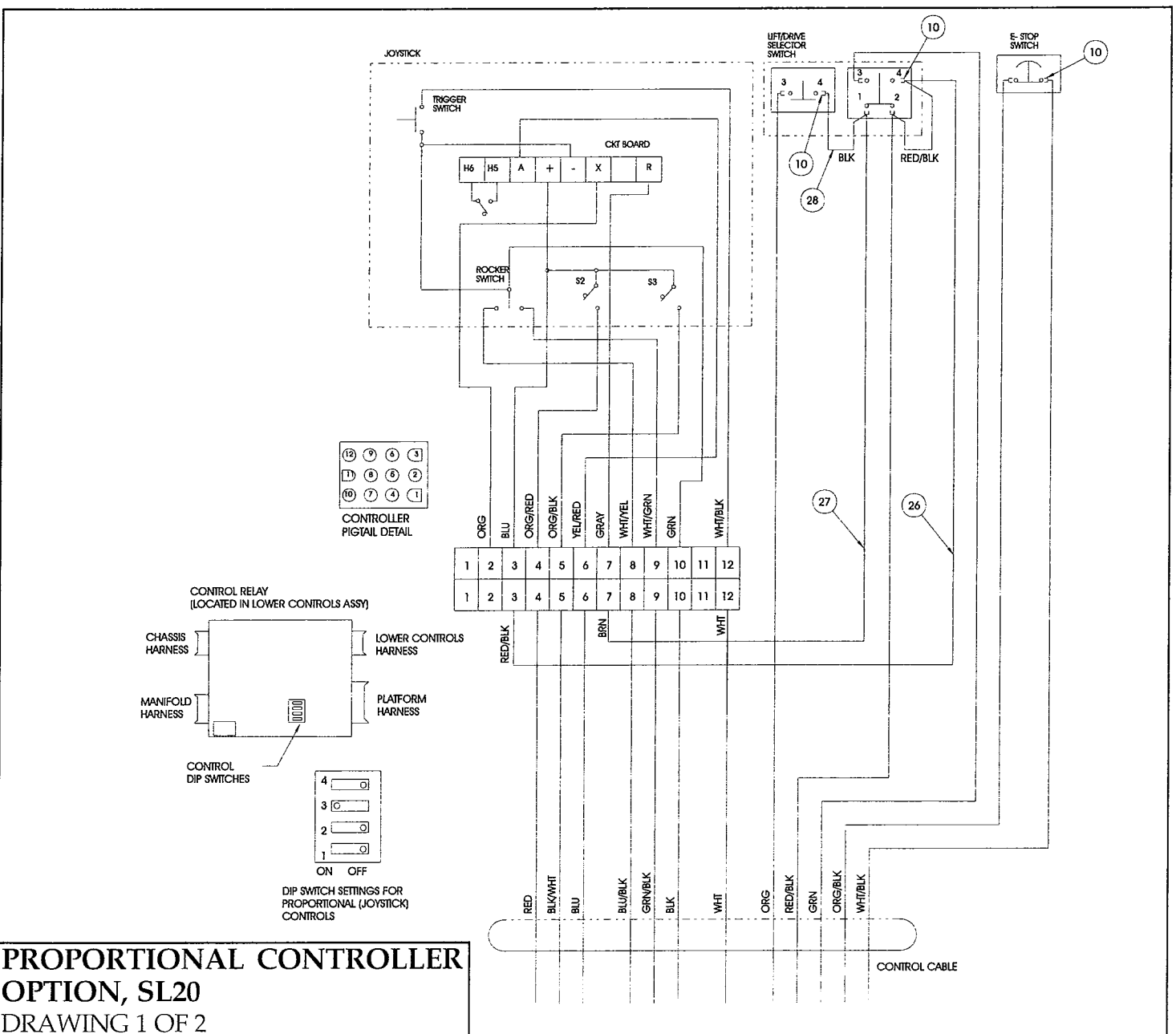

Illustrated Parts Breakdown

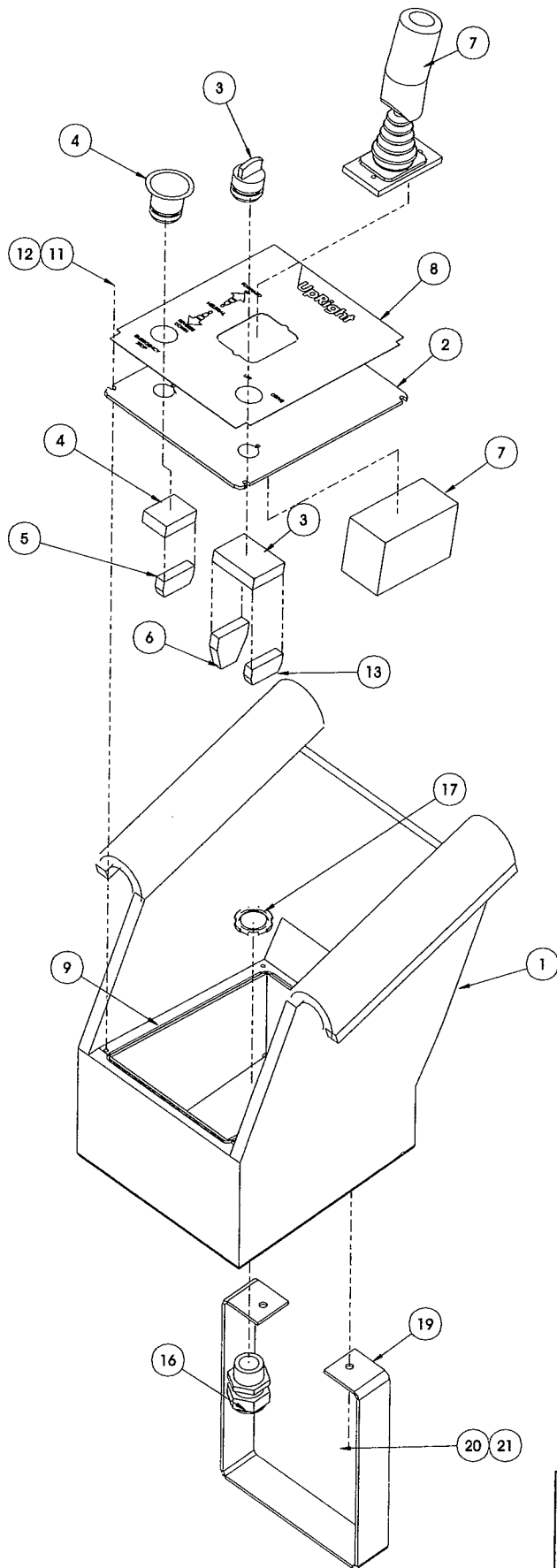

**PROPORTIONAL CONTROLLER
OPTION, SL20**
DRAWING 2 OF 2

Illustrated Parts Breakdown

HR METER WITH BATTERY LOW VOLTAGE INDICATOR OPTION, SL20 101195-000

ITEM	PART	DESCRIPTION	QTY.
1	101005-001	CONTROL MODULE ASSEMBLY	REF
2	029959-000	VOLTAGE/HOURMETER	1
3	029601-013	CONNECTOR, RING TERMINAL	3
4	029610-002	CONNECTOR, FORK TERMINAL	2
5	029454-099	WIRE 16 AWG RED	1'
6	029456-099	WIRE 16 AWG YELLOW	1.33'
7	029931-003	CONNECTOR, PUSH TERMINAL	4
8	029452-099	WIRE 16 AWG BLACK	2'
9	066805-011	CONTACT BLOCK, N.C.	1

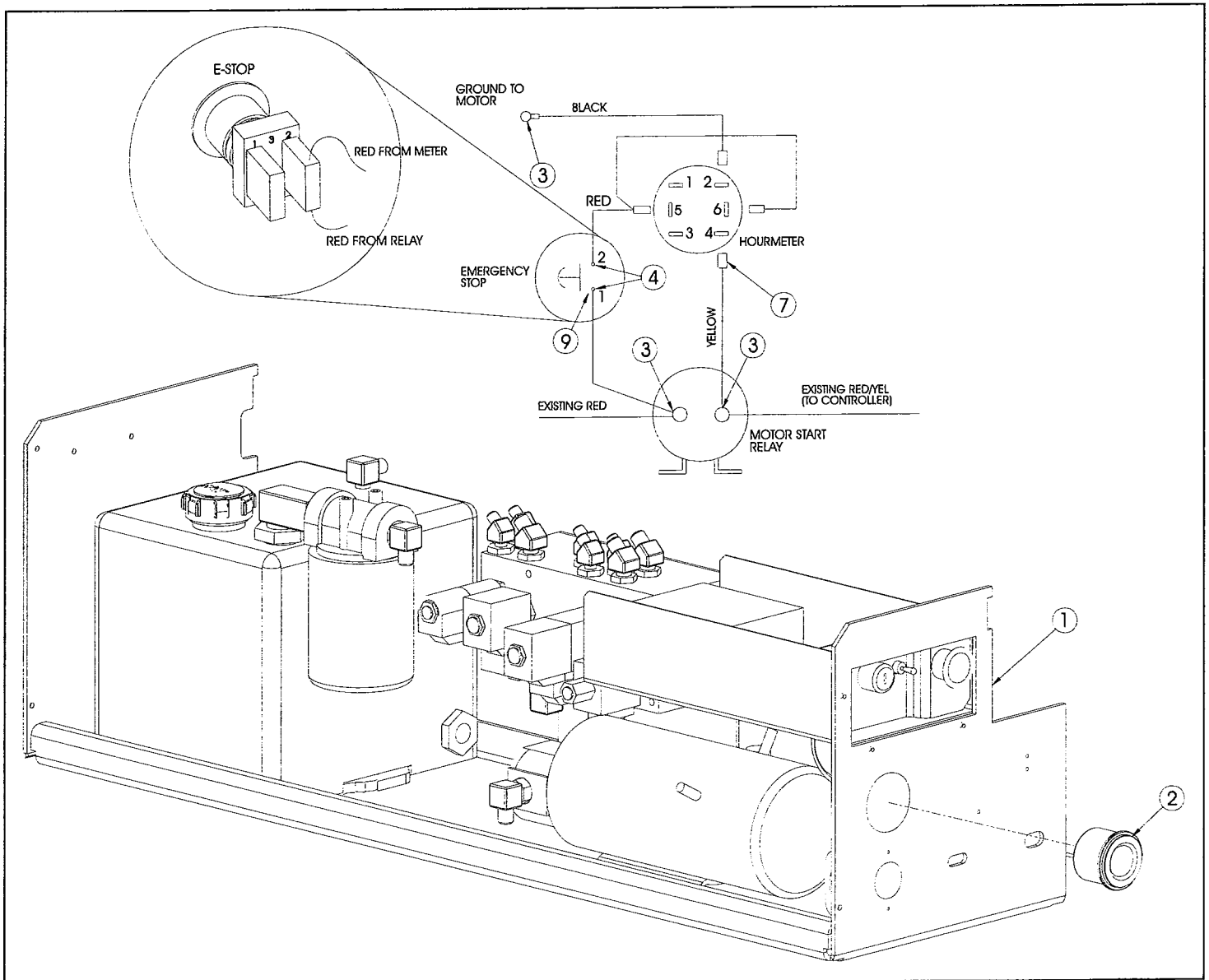

Illustrated Parts Breakdown

Section
6.2

HOUR METER OPTION SL20 101191-000

ITEM	PART	DESCRIPTION	QTY.
1	101005-000	CONTROL MODULE ASSEMBLY	REF
2	015752-000	VOLTAGE/HOURMETER	1
3	029601-013	CONNECTOR, RING TERMINAL	2
5	029454-099	WIRE 16 AWG RED	1'
6	029456-099	WIRE 16 AWG YELLOW	1.33'
7	029931-003	CONNECTOR, PUSH TERMINAL	2

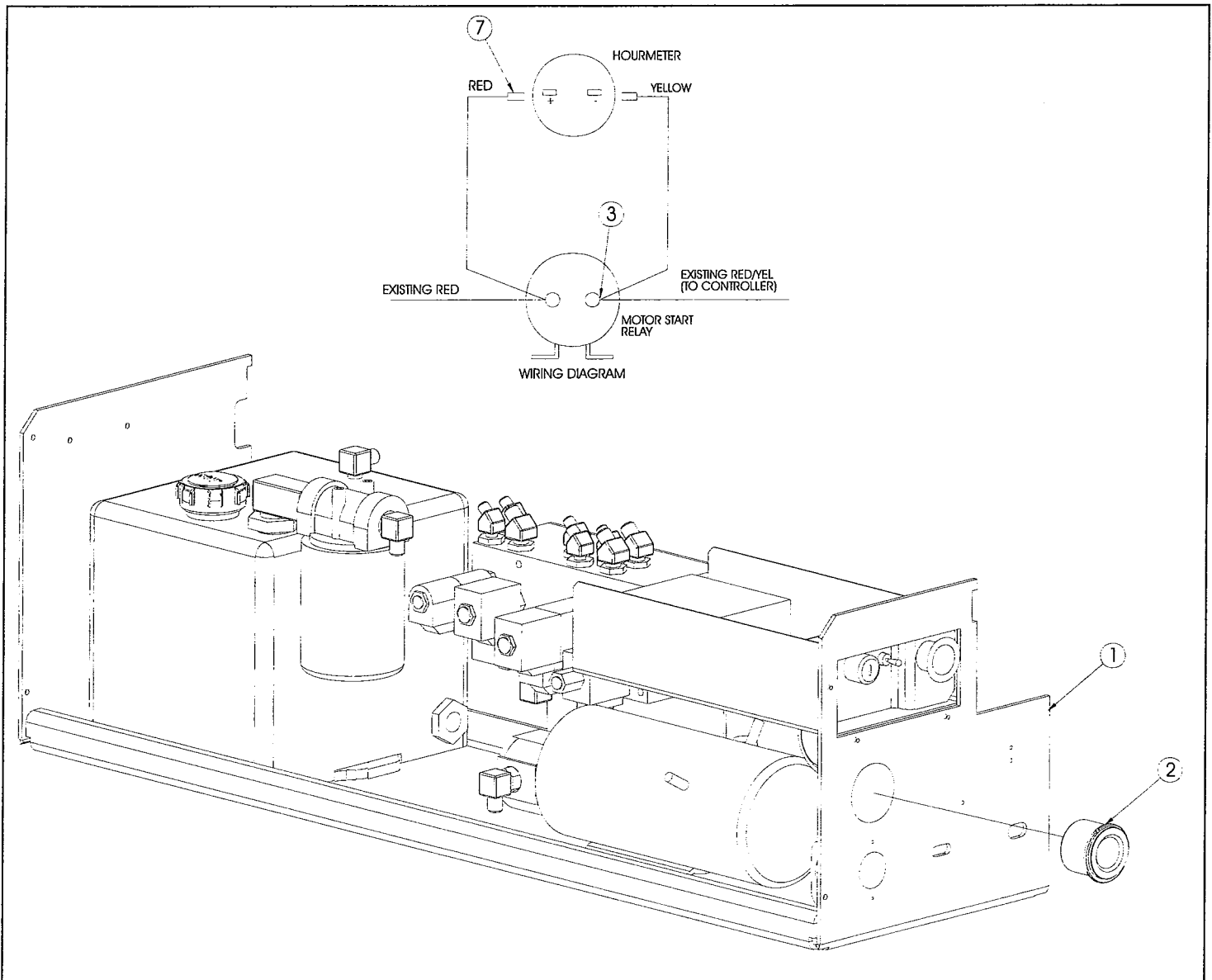
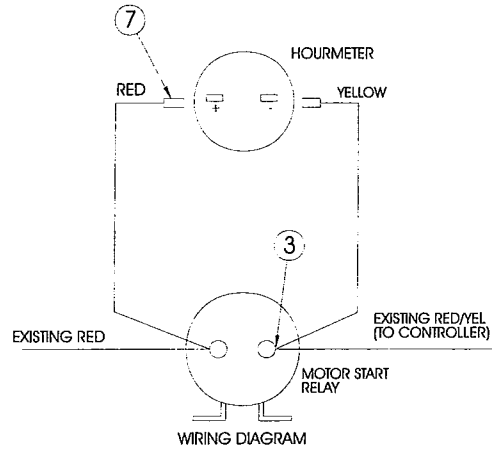

MOTION ALARM OPTION
SL20
101193-000

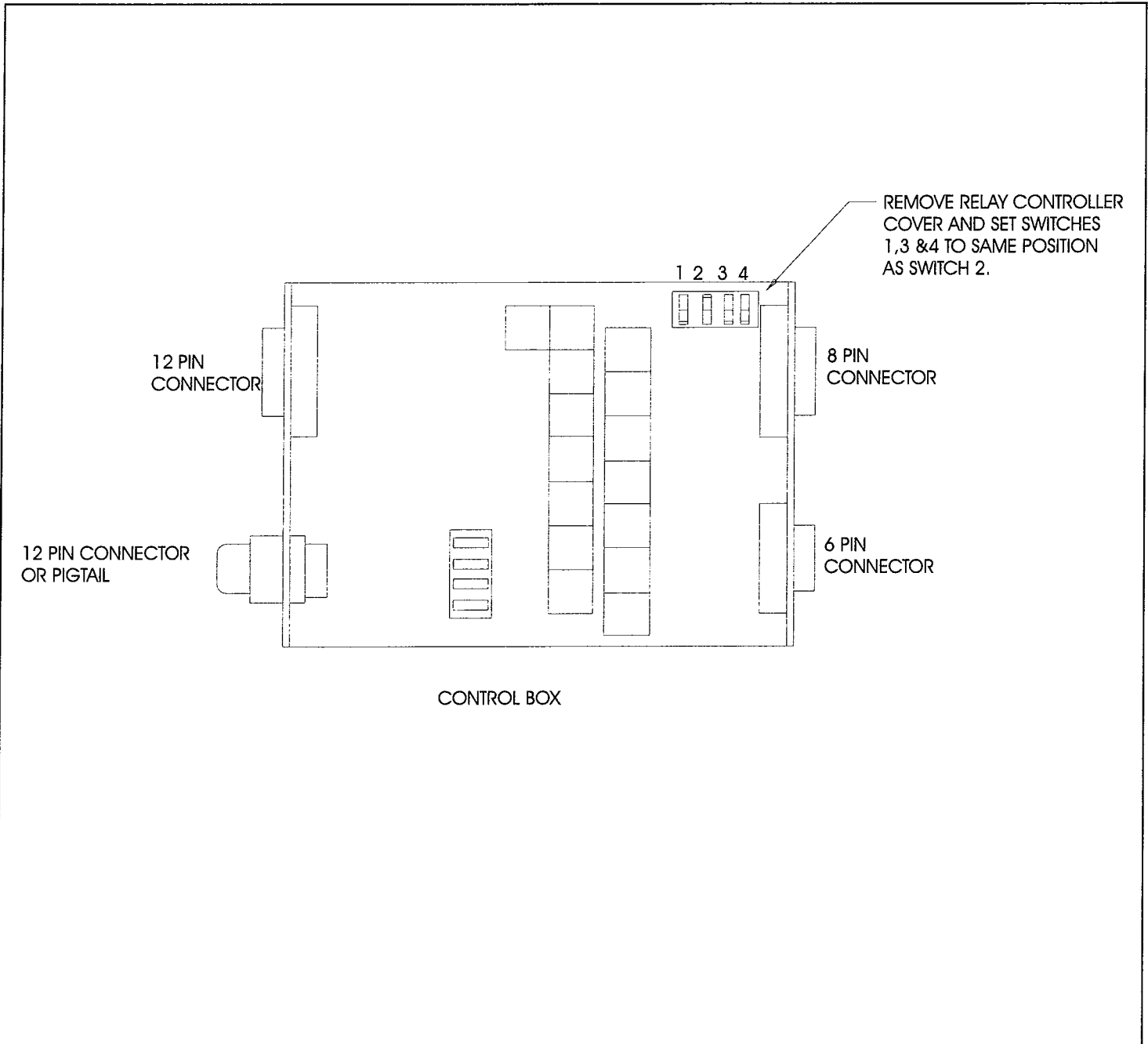

UpRight

Call Toll Free in U.S.A.

1-800-926-LIFT

UpRight, Inc.

1775 Park Street

Selma, California 93662

TEL: 559/896-5150

FAX: 559/896-9012

PARTSFAX: 559/896-9244

P/N 101199-001

1.99 x x