

Service - and - Parts Manual

TM12 UI 12 M-Lift Work Platform

Serial Numbers M30176 - M30642

Publication Number: 107100-000

UpRight

TM 12

Serial Numbers M30176 – M30642

When contacting UpRight for service or parts information, be sure to include the MODEL and SERIAL NUMBERS from the equipment nameplate. Should the nameplate be missing, the SERIAL NUMBER is also stamped on top of the chassis above the front axle pivot.

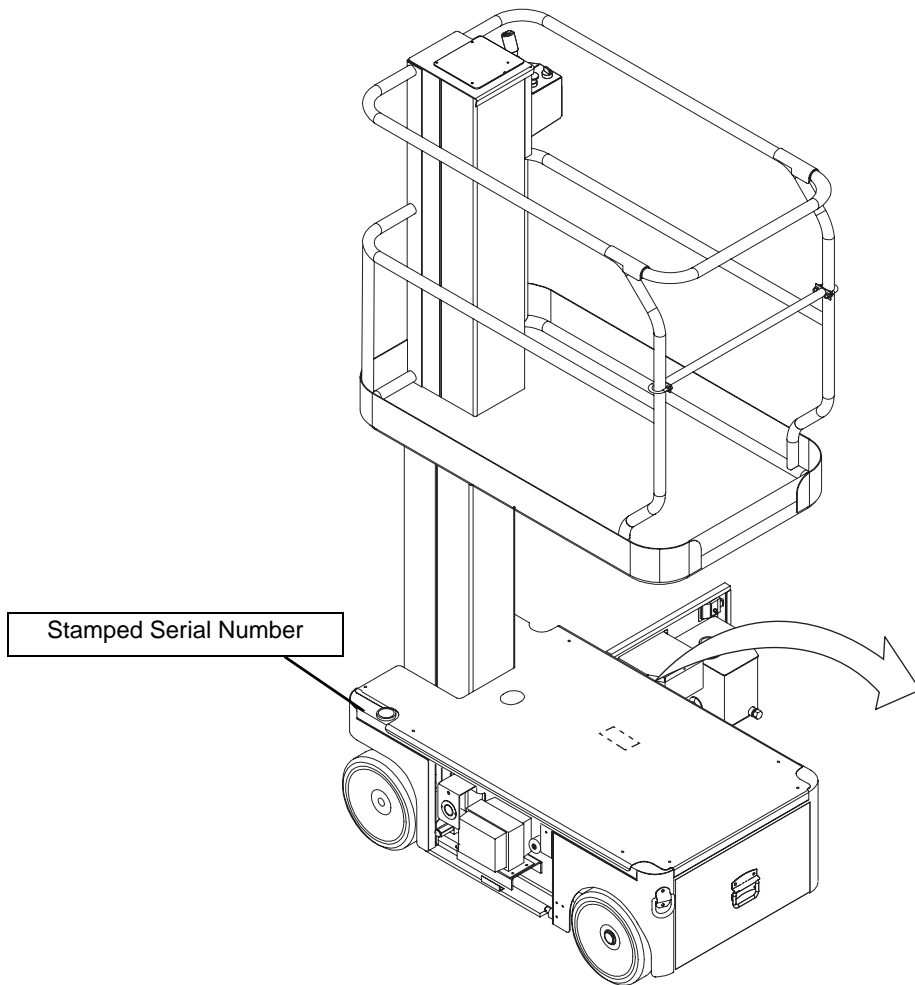

CE	
Model _____	Serial number: _____
Machine weight _____ kg	Mfg. date: _____
Maximum wheel load: _____	
Maximum allowable incline of machine when elevated: _____ deg.	
Occupants and equipment must not exceed the rated maximum load: _____ kg Maximum platform occupants: _____	
Maximum allowable side force on platform: _____ N	
Maximum platform height: _____ m	
Maximum platform reach: _____ m	
Maximum allowable wind speed: _____ m/s=Beaufort scale _____	
Maximum hydraulic system pressure: _____ bar	
Maximum system voltage: _____ Vdc	
This machine is manufactured to comply with Machinery directive 89-392/CEE	
CAUTION: CONSULT OPERATOR'S MANUAL BEFORE USE.	

UpRight USA

2686 S. Maple Avenue
Fresno, California 93725

TEL:(559) 443-6600

FAX:(559) 268-1756

PARTS:1-866-843-3381

EMAIL:info@uidistribution.com

www.uidistribution.com

UpRight

Call Toll Free in U.S.A.

1-866-843-3350

FOREWORD

This manual contains instructions for the maintenance of the machine. Referring to the Operator Manual will aid in understanding the operation and function of the various components and systems of the machine, and help in diagnosing and repair of the machine.

All information contained in this manual is based on the latest product information available at the time of printing. We reserve the right to make changes at any time without notice. No part of this publication may be reproduced, stored in retrieval system, or transmitted, in any form by any means, electronic, mechanical, photocopying, recording, or otherwise, without the prior written permission of the publisher. This includes text, figures and tables.

This manual consists of five (5) parts.

OPERATOR MANUAL

A copy of the Operator Manual that is stored on every UpRight Aerial Work Platform.

SECTION 1 - GENERAL INFORMATION

Contains generic information relevant to all UpRight Aerial Work Platforms.

SECTION 2 - SERVICE AND REPAIR

Detailed information specific to this UpRight Aerial Work Platform.

SECTION 3 - TROUBLESHOOTING

Causes and solutions to typical problems.

SECTION 4 - SCHEMATICS

Electric and Hydraulic schematics.

PARTS MANUAL

IMPORTANT

**UI 12 M-Lifts and TM12 Machines with Serial Number range of
———— M30176 through M30642 ————**

have the possibilities of two different:

- Motor Control Systems
- Wire harnesses
- Hydraulic Valve Blocks
- Upper Control Box
- Lower control Box

Assure that you are looking at the correct drawings before you order parts. These components are broken apart by numbers.



OPERATION MANUAL

TM12 — Ui 12 M-LIFT

Serial Numbers M30176 – M30642

WARNING

All personnel shall carefully read, understand and follow all safety rules, operating instructions, and the Scaffold Industry Association's MANUAL OF RESPONSIBILITIES of ANSI A92.6-1999 before performing maintenance on or operating any *Ui* Aerial Work Platform..

Safety Rules

Electrocution Hazard



NEVER operate the machine within ten (10) feet of power lines.
THIS MACHINE IS NOT INSULATED.

Tip Over Hazard

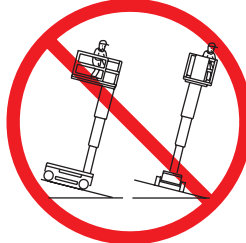

NEVER elevate the platform or drive the machine while elevated unless the machine is on a firm, level surface.

Collision Hazard



NEVER position the platform without first checking for overhead obstructions or other hazards.

Fall Hazard



NEVER climb, stand, or sit on platform guardrails or midrail.

USE OF THE AERIAL WORK PLATFORM: This aerial work platform is intended to lift persons and his tools as well as the material used for the job. It is designed for repair and assembly jobs and assignments at overhead workplaces (ceilings, cranes, roof structures, buildings etc.). All other uses of the aerial work platform are prohibited!

THIS AERIAL WORK PLATFORM IS NOT INSULATED! For this reason it is imperative to keep a safe distance from live parts of electrical equipment!

Exceeding the specified permissible maximum load **is prohibited!** See "Platform Capacity" on page 4 for details.

The use and operation of the aerial work platform as a lifting tool or a crane **is prohibited!**

NEVER exceed the manual force allowed for this machine. See "Manual Force" on page 4 for details.

DISTRIBUTE all platform loads evenly on the platform.

NEVER operate the machine without first surveying the work area for surface hazards such as holes, drop-offs, bumps, curbs, or debris; and avoiding them.

OPERATE machine only on surfaces capable of supporting wheel loads.

NEVER operate the machine when wind speeds exceed this machine's wind rating. See "Beaufort Scale" on page 4 for details.

IN CASE OF EMERGENCY push EMERGENCY STOP switch to deactivate all powered functions.

IF ALARM SOUNDS while platform is elevated, STOP, carefully lower platform. Move machine to a firm, level surface.

Climbing up the railing of the platform, standing on or stepping from the platform onto buildings, steel or prefab concrete structures, etc., **is prohibited!**

Dismantling the entry gate or other railing components **is prohibited!** Always make certain that the entry gate is closed and securely locked!

It is prohibited to keep the entry gate in an open position when the platform is raised!

To extend the height or the range by placing of ladders, scaffolds or similar devices on the platform **is prohibited!**

NEVER perform service on machine while platform is elevated without blocking elevating assembly.

INSPECT the machine thoroughly for cracked welds, loose or missing hardware, hydraulic leaks, loose wire connections, and damaged cables or hoses before using.

VERIFY that all labels are in place and legible before using.

NEVER use a machine that is damaged, not functioning properly, or has damaged or missing labels.

To bypass any safety equipment **is prohibited** and presents a danger for the persons on the aerial work platform and in its working range.

NEVER charge batteries near sparks or open flame. Charging batteries emit explosive hydrogen gas.

Modifications to the aerial work platform **are prohibited** or permissible only at the approval by *Ui*

AFTER USE, secure the work platform from unauthorized use by turning the keyswitch off and removing key.

CONTENTS

Introduction	4
General Description	4
Special Limitations	5
Platform Capacity	5
Manual Force	5
Beaufort Scale	5
Controls and Indicators	6
Pre-Operation Safety Inspection	6
System Function Inspection	7
Operation	8
Travel With Platform Lowered	8
Steering	8
Elevating Platform	8
Travel With Platform Elevated	8
Lowering Platform	8
Emergency Lowering	9
Parking Brake Release	9
After Use Each Day	9
Transporting the Machine	10
By Crane	10
By Forklift	10
By Truck	10
Maintenance	11
Blocking the Elevating Assembly	11
Installation	11
Removal	11
Hydraulic Fluid	11
Check Hydraulic Fluid	11
Battery Maintenance	12
Battery Charging	13
Inspection and Maintenance Schedule	14
Daily Preventative Maintenance Checklist	15
Labels	16
Specifications	17

INTRODUCTION

This manual covers all models of the **Ui 12 M-LIFT** Aerial Work Platform. This manual must be stored on the machine at all times.

Read, understand and follow all safety rules and operating instructions before attempting to operate the machine.

GENERAL DESCRIPTION

1. Platform

! WARNING !

DO NOT use the maintenance platform without guardrails properly assembled and in place

2. Entry Bar

3. Elevating Mast

4. Platform Controls

5. Manual Case

6. Electrical Box

7. Hydraulic Reservoir

8. Level Sensor

9. Battery Tray

10. Emergency Lowering Valve

11. Battery Charger

12. Drive Relief Valve

13. Charger Outlet Plug

Figure 1:

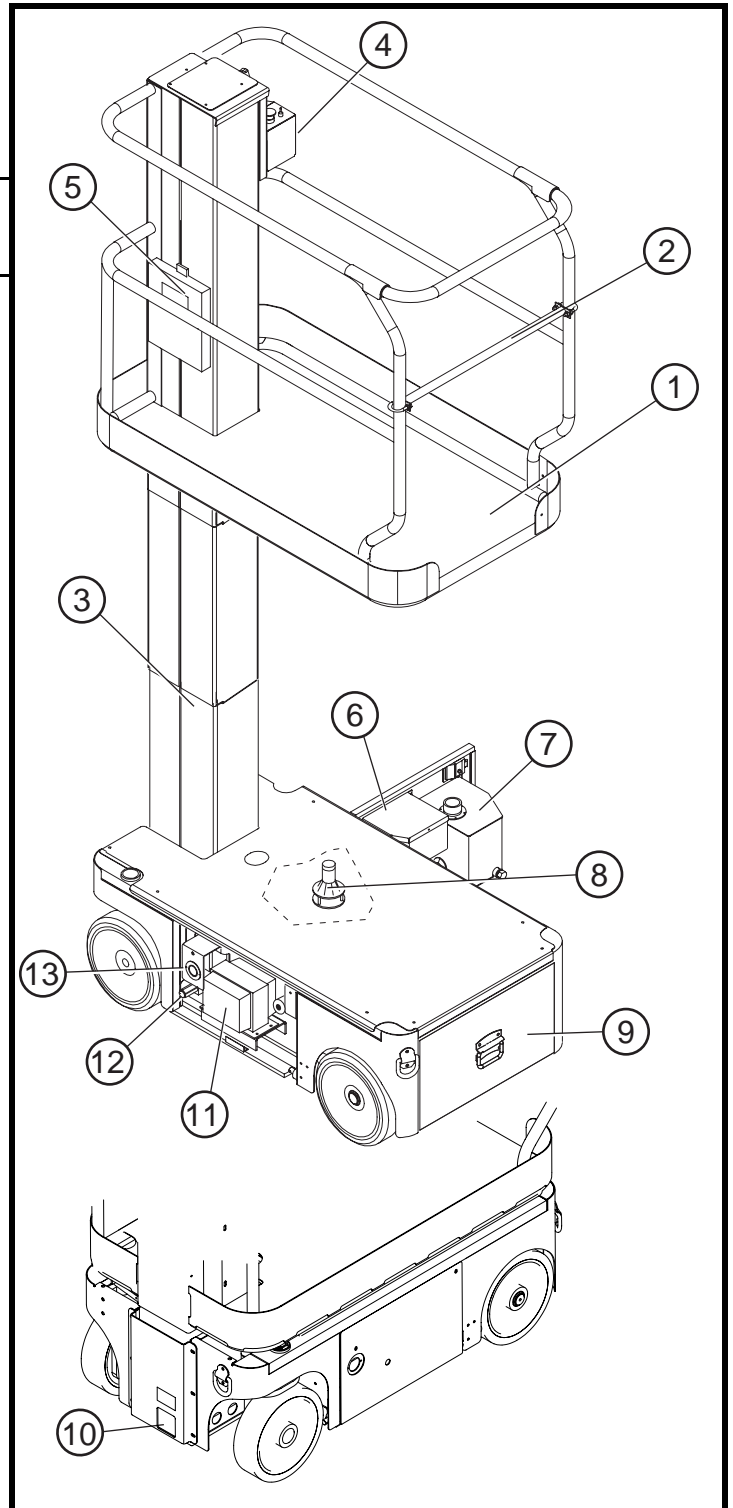

SPECIAL LIMITATIONS

Travel with the platform raised is limited to creep speed range.

Elevating the platform is limited to firm, level surfaces only.

⚠ DANGER ⚠

The elevating function shall ONLY be used when the work platform is level and on a firm surface.

The work platform is NOT intended to be driven over uneven, rough, or soft terrain.

PLATFORM CAPACITY

The maximum platform capacity for the Ui12M-LIFT is 227 kg (500 lbs). Two people may occupy the platform indoors, while only one may occupy the platform outdoors.

⚠ DANGER ⚠

DO NOT exceed the maximum platform capacity or the platform occupancy limits for this machine.

MANUAL FORCE

Manual force is the force applied by the occupants to objects such as walls or other structures outside the work platform.

The maximum allowable manual force is limited to 200 N (45 lbs.) of force per occupant, with a maximum of 400 N (90 lbs.) for two occupants.

⚠ DANGER ⚠

DO NOT exceed the maximum amount of manual force for this machine.

BEAUFORT SCALE

Never operate the machine when wind speeds exceed 25 km/h (15 mph) [Beaufort scale 4].

BEAUFORT RATING	WIND SPEED				GROUND CONDITIONS
	m/s	km/h	ft/s	mph	
3	3,4-5,4	12,25-19,4	11.5-17.75	7.5-12.0	Papers and thin branches move, flags wave.
4	5,4-8,0	19,4-28,8	17.75-26.25	12.0-18	Dust is raised, paper whirls up, and small branches sway.
5	8,0-10,8	28,8-38,9	26.25-35.5	18-24.25	Shrubs with leaves start swaying. Wave crests are apparent in ponds or swamps.
6	10,8-13,9	38,9-50,0	35.5-45.5	24.5-31	Tree branches move. Power lines whistle. It is difficult to open an umbrella.
7	13,9-17,2	50,0-61,9	45.5-56.5	31.-38.5	Whole trees sway. It is difficult to walk against the wind.

⚠ DANGER ⚠

Never operate the machine with a platform load greater than the rated capacity.

CONTROLS AND INDICATORS

The operator shall know the location of each control and indicator and have a thorough knowledge of the function and operation of each before attempting to operate the unit.

Figure 2: Controls and indicators | Serial # M30176 - M30338

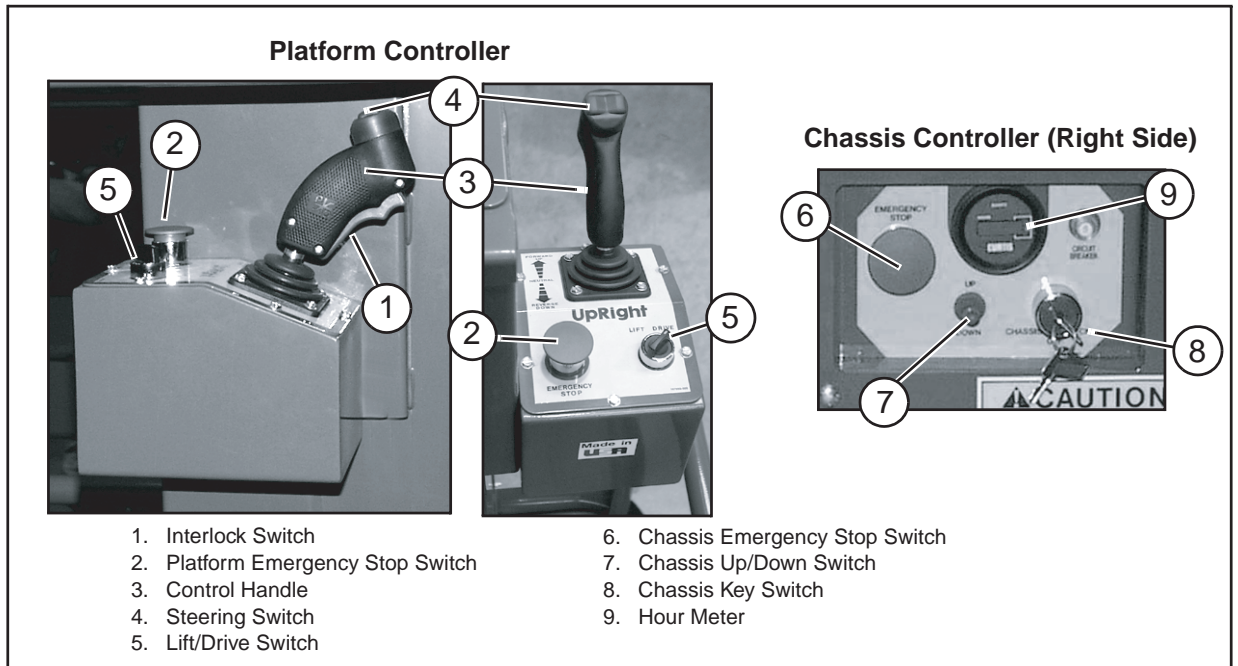
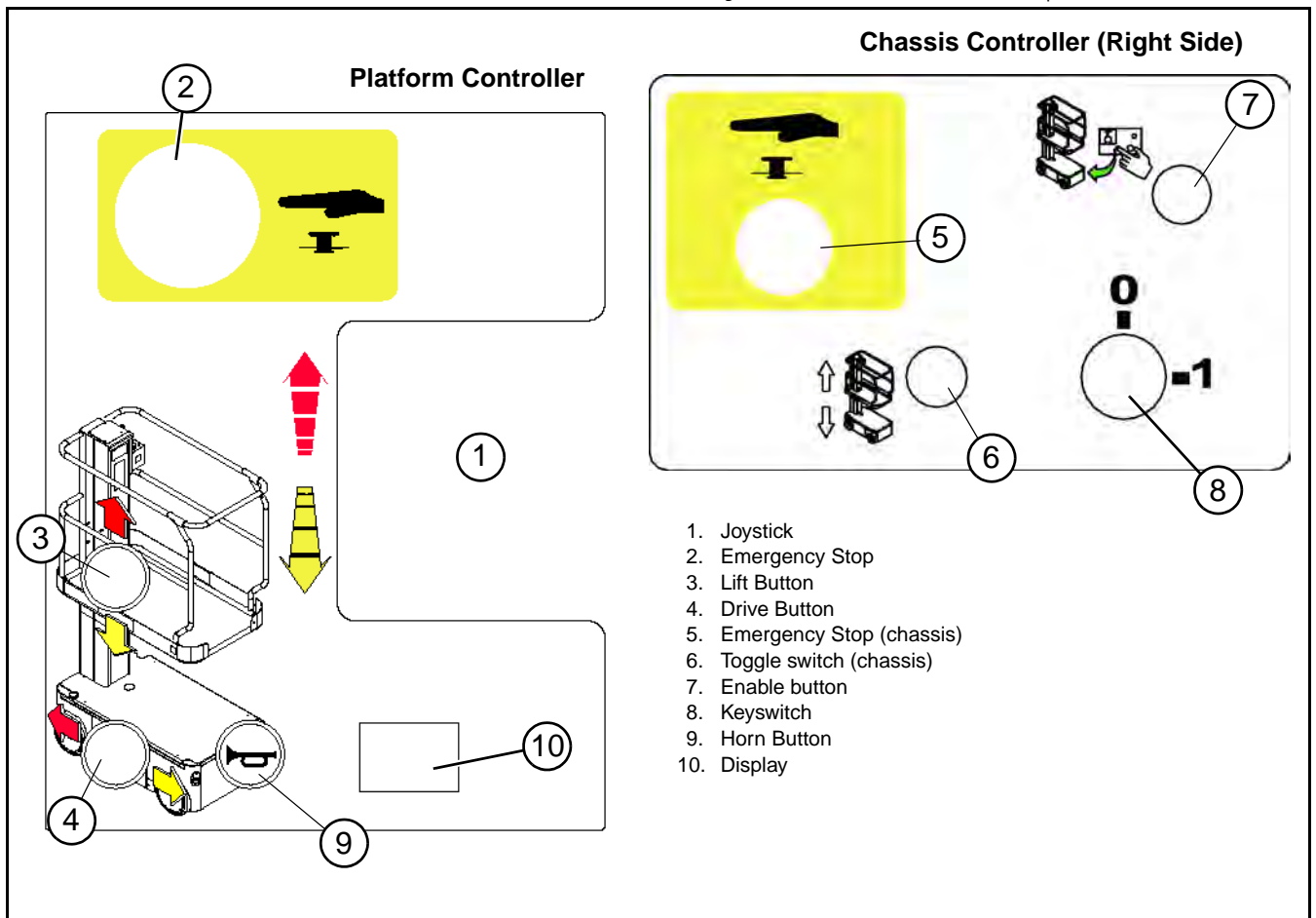

Figure 3: Controls and Indicators ITT | Serial # M30339 - M30642



PRE-OPERATION SAFETY INSPECTION

NOTE: Carefully read, understand and follow all safety rules, operating instructions, labels and National Safety Instructions/Requirements. Perform the following steps each day before use.

1. Open the Chassis Door and inspect for damage, fluid leaks or missing parts.
2. Check the level of the hydraulic fluid with the platform fully lowered. Open the Chassis Door and remove the reservoir cap, fluid should be visible on the dipstick. Add recommended hydraulic fluid if necessary. See "" on page 20.
3. Check that the fluid level in the batteries is correct. See "Battery Maintenance" on page 12.
4. Verify that the batteries are charged.
5. Check that the A.C. extension cord has been disconnected from the chassis outlet.
6. Check that all guardrails are in place and all fasteners are properly tightened.
7. Inspect the machine thoroughly for cracked welds and structural damage, loose or missing hardware, hydraulic leaks, damaged control cable and loose wire connections.
8. Ensure that all safety labels are in place and in good condition before operating.

SYSTEM FUNCTION INSPECTION

Refer to Figure 1 and Figure 3 for the locations of various controls and indicators.

⚠ WARNING ⚠

STAND CLEAR of the work platform while performing the following checks.

Before operating the machine, survey the work area for surface hazards such as holes, drop-offs, bumps and debris.

Check in **ALL** directions, including above the work platform, for obstructions and electrical conductors.

Protect the control console cable from possible damage while performing checks.

1. Move the machine, if necessary, to an unobstructed area to allow for full elevation.
2. Turn the Chassis and Platform Emergency Stop Switches ON by pulling the buttons out.
3. Turn the Chassis Key Switch to ON.
4. Push the Chassis Lift Switch to the UP position and fully elevate the platform.
5. Visually inspect the mast assembly for damage or erratic operation. Check for missing or loose parts.
6. Verify that the depression mechanism supports have rotated into position under the machine.
7. Check Level Sensor operation:
 - a. Open the door.
 - b. Push and hold the sensor off of level.
 - c. Push the Chassis Lift Switch to the UP position.
 - The alarm should sound, and the platform should not lift.
 - d. Close and latch the door.
8. Partially lower the platform by pushing the Chassis Lift Switch to DOWN, and check the operation of the audible lowering alarm.
9. Check the Chassis Emergency Lowering Valve for proper operation (see Figure 5):
 - a. Open the valve by pulling the knob out.
 - b. Once the platform is fully lowered, close the valve by releasing the knob.
10. Push the Chassis Emergency Stop Switch down to the OFF position. All machine functions should be disabled. Pull out the Chassis Emergency Stop Switch to resume.
11. Mount the platform.
12. Check that the route is clear of persons, obstructions, holes and drop-offs, is level and capable of supporting the wheel loads.
13. After mounting platform, lower the bar across the entrance.
14. Select DRIVE mode.
15. While depressing the Interlock Switch, slowly position the Control Lever to FORWARD then REVERSE to check for speed and directional control. The farther you push or pull the Control Lever from center the faster the machine will travel.
16. Push the Steering Switch RIGHT then LEFT to check for steering control.
17. Push the Platform Emergency Stop Switch down to the OFF position. All machine functions should be disabled. Pull out the Platform Emergency Stop Switch to resume.

Figure 4: Level Sensor Location

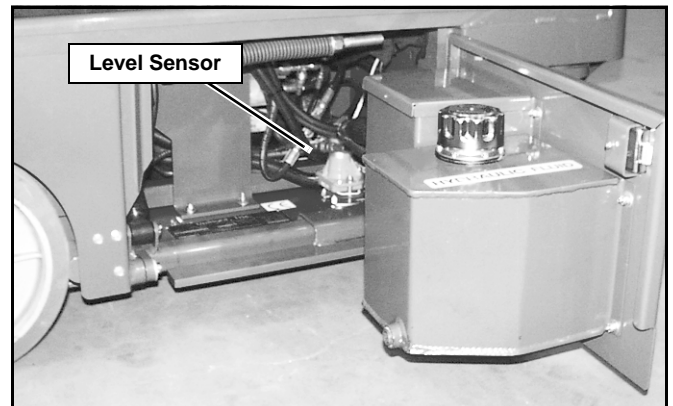

OPERATION

Before operating the machine, ensure that the Pre-Operation Safety Inspection has been completed and that any deficiencies have been corrected. **Never operate a damaged or malfunctioning machine.** The operator must be thoroughly trained on this machine.

TRAVEL WITH PLATFORM LOWERED

1. Check that the route is clear of people, obstructions, holes and drop-offs, is level and is capable of supporting wheel loads.
2. Verify that the Chassis Key Switch is turned to ON and the Chassis Emergency Stop Switch is ON, (pull button out).
3. After mounting the platform, lower the bar across entrance.
4. Check clearances above, below and to the sides of the machine.
5. Pull the Controller Emergency Stop switch up to the ON position.
6. Select DRIVE mode.
7. While depressing the Interlock Switch, slowly push or pull the Control Lever to FORWARD or REVERSE position to travel in the desired direction. The farther you push or pull the Control Lever from center the faster the machine will travel.

STEERING

NOTE: Steering is not self-centering. Wheels must be returned to straight ahead position by operating the Steering Switch.

1. Select DRIVE mode.
2. While depressing the Interlock Switch, push the Steering Switch to RIGHT or LEFT to turn the wheels in the desired direction. Observe the tires while maneuvering the machine to ensure proper direction.

ELEVATING PLATFORM

1. Select LIFT mode.
2. While depressing the Interlock Switch, push Control Lever forward to UP, the farther you push the Control Lever the faster the Platform will elevate.
3. If the machine is not level the Tilt Alarm will sound and the machine will not lift or drive. If the Tilt alarm sounds the platform must be lowered and the machine moved to a level location before attempting to re-elevate the Platform.

TRAVEL WITH PLATFORM ELEVATED

NOTE: The machine will travel at reduced speed when the platform is elevated.

1. Check that the route is clear of persons, obstructions, holes and drop-offs, is level and capable of supporting the wheel loads.
2. Check clearances above, below and to the sides of the platform.
3. Select DRIVE mode.
4. While depressing the Interlock Switch, push Control Lever to FORWARD or REVERSE for desired direction of travel.
5. If the machine is not level the Tilt Alarm will sound and the machine will not lift or drive. If the Tilt alarm sounds the platform must be lowered and the machine moved to a level location before attempting to re-elevate the Platform.

LOWERING PLATFORM

1. Select LIFT mode.
2. While depressing the Interlock Switch, pull back on the Control Lever.

EMERGENCY LOWERING

⚠ WARNING ⚠

If the platform should fail to lower, **NEVER** climb down the elevating assembly.
Stand clear of the elevating assembly while operating the Emergency Lowering Valve Knob.

Ask a person on the ground to open the Emergency Lowering Valve to lower the platform. The Emergency Lowering Valve is located at the front of the chassis.

1. Open the Emergency Lowering Valve by pulling the knob out.
2. To close, release the knob.

NOTE: The platform will not elevate if the Emergency Lowering Valve is open.

Figure 5: Emergency Lowering Valve

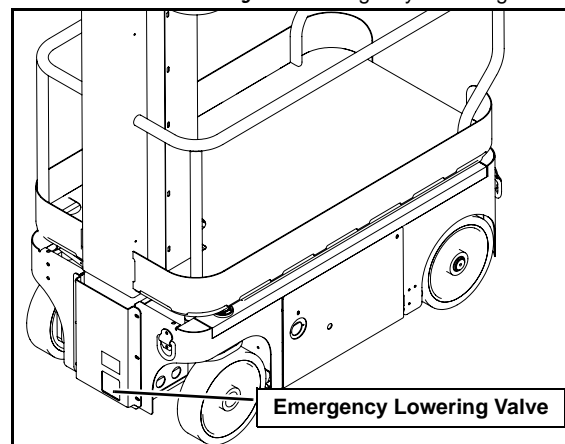

PARKING BRAKE RELEASE

Perform the following procedure only when the machine will not operate under its own power and it is necessary to move the machine, or when winching onto a trailer to transport.

1. Remove the spring compression nut so the spring is loose and the brake bars are away from the tires.
2. The machine will now roll when pushed or pulled.

After moving the machine and before normal operation:

1. Replace the spring compression nut and tighten until the spring measures 22,2-22,9 cm (8¾"-9") in length, verify that the brake bars have fully engaged the tires before the machine is operated.

Figure 6: Parking Brake Release

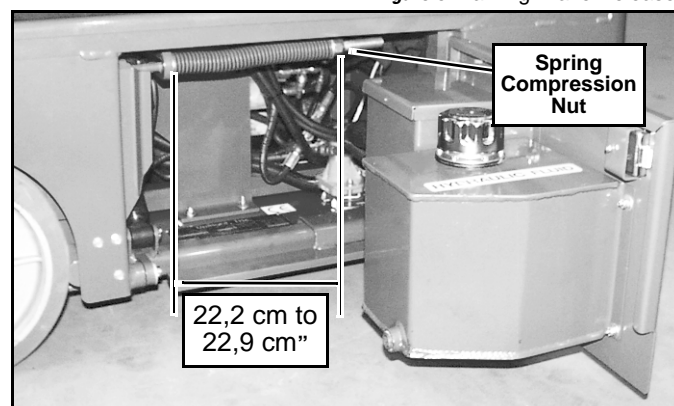

⚠ WARNING ⚠

Never tow faster than 0,3 m/sec. (1 ft./sec.).

Never operate the machine with the parking brakes released. Serious injury or damage could result.

AFTER USE EACH DAY

1. Ensure that the platform is fully lowered.
2. Park the machine on a firm level surface, preferably under cover, secure against vandals, children and unauthorized operation.
3. Turn the Chassis Key Switch to OFF and remove the key to prevent unauthorized operation.

TRANSPORTING THE MACHINE

BY CRANE

Secure the straps to chassis lifting/tie down points only.

BY FORKLIFT

⚠ DANGER ⚠

Forklifting is for transport only.

See specifications for weight of machine and be certain that forklift is of adequate capacity to lift the machine.

Forklift from the side by lifting under the Chassis.

BY TRUCK

1. Maneuver the machine into transport position and chock wheels.
2. Secure the machine to the transport vehicle with chains or straps of adequate load capacity attached to the chassis lifting/tie down points.

CAUTION

Overtightening of the chains or straps attached to the Tie Down lugs may result in damage to the machine.

Figure 7: Transporting the Machine

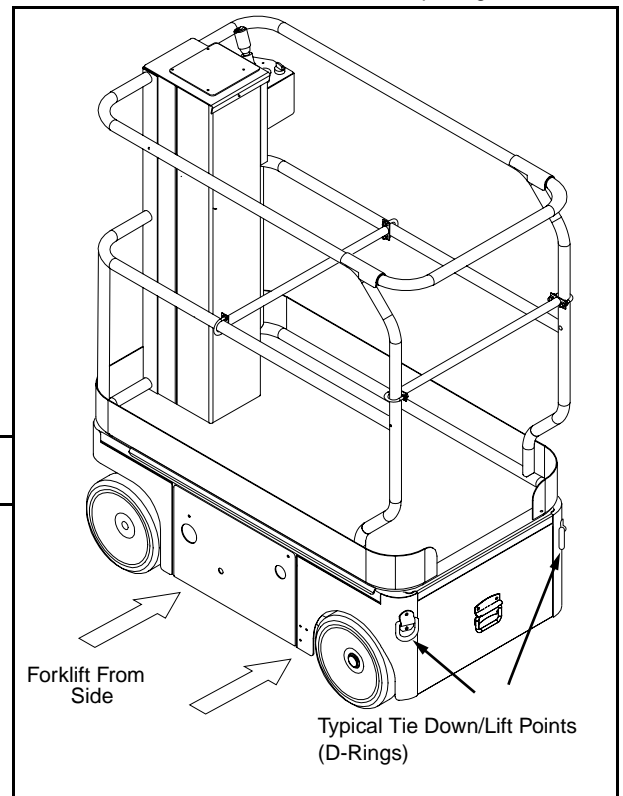

MAINTENANCE

⚠ WARNING ⚠

Never perform service while the platform is elevated without first blocking the elevating assembly.
DO NOT stand in the elevating assembly area while deploying or storing the brace.

BLOCKING THE ELEVATING ASSEMBLY

INSTALLATION

1. Park the machine on firm level ground.
2. Verify that both Emergency Stop Switches are ON.
3. Turn and hold the Chassis Key Switch to CHASSIS.
4. Position the Chassis Lift Switch to UP and elevate the platform approximately 1,2 m (4 ft.).
5. Place a solid wood block, 51mm x 100mm x 45cm (2"x 4"x18") between the second mast section and Chassis just behind the mast assembly.
6. Push the Chassis Lift Switch to the DOWN position and gradually lower the platform until the second mast section is supported by the block.

Figure 8: Supporting the Elevating Assembly

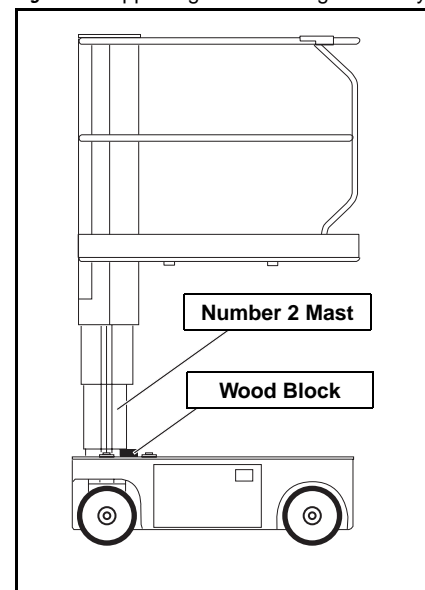

REMOVAL

1. Push the Chassis Lift Switch to the UP position and gradually raise platform until the wood block can be removed.
2. Remove the block.
3. Push the Chassis Lift Switch to the DOWN position and completely lower the platform.

HYDRAULIC FLUID

The hydraulic fluid reservoir is located in the chassis door.

NOTE: Never add fluid if the platform is elevated.

CHECK HYDRAULIC FLUID

1. Make sure that the platform is fully lowered.
2. Open the chassis door.
3. Remove the filler cap from the hydraulic fluid reservoir.
4. Check the fluid level on the dipstick on the filler cap.
5. Add the appropriate fluid to bring the level to the FULL mark. See "" on page 20

Figure 9: Hydraulic Fluid Reservoir and Dipstick



BATTERY MAINTENANCE

⚠ WARNING ⚠

Hazard of explosive gas mixture. Keep sparks, flame, and smoking material away from batteries.

Always wear safety glasses when working near batteries.

Battery fluid is highly corrosive. Thoroughly rinse away any spilled fluid with clean water.

*Always replace batteries with **Ui** batteries or manufacturer approved replacements weighing 26,3 kg (58 lbs.) each.*

- Check the battery fluid level daily, especially if the machine is being used in a warm, dry climate.
- If electrolyte level is lower than 10 mm ($\frac{3}{8}$ in.) above the plates add distilled water only. DO NOT use tap water with high mineral content, as it will shorten battery life.
- Keep the terminals and tops of the batteries clean.
- Refer to the Service Manual to extend battery life and for complete service instructions.

Figure 10: Access to Batteries



BATTERY CHARGING

Charge the batteries at the end of each work shift or sooner if the batteries have been discharged.



Charge the batteries in a well ventilated area.

Do not charge the batteries when the machine is near a source of sparks or flames.

Permanent damage to the batteries will result if the batteries are not immediately recharged after discharging.

Never leave the battery charger operating for more than two days.

Never disconnect the cables from the batteries when the charger is operating.

Keep the charger dry.

Figure 11: Battery Charger

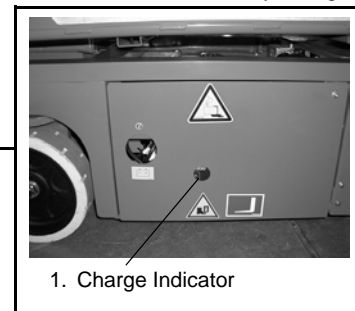

1. Check the battery fluid level (see Battery Maintenance).
2. Connect an extension cord (1,5 mm² [**12 gauge**] minimum conductor diameter; 15 m (**50 ft.**) maximum length) to the charger plug located at the left side of the chassis.

3. The charger turns on automatically after a short delay. Look through the charge indicator cutout to check the state of charge.

- 0 - 50% charge:
 - First Light -*BLINKING*
 - Second and Third Light -*OFF*
- 50% - 75% Charge:
 - First Light -*ON*
 - Second Light -*BLINKING*
 - Third Light -*OFF*
- 75% - 100% Charge:
 - First and Second Light -*ON*
 - Third Light -*BLINKING*
- Charge Complete
 - All Lights -*ON*
- The charger automatically shuts down to low current after charging is complete and all lights turn ON.
- The charger continues at low current (equalizing charge) for 3-4 hours, then charging current shuts off completely.
- Lights remain ON until the AC power supply is disconnected.

Figure 12: Charge Indicator Lights

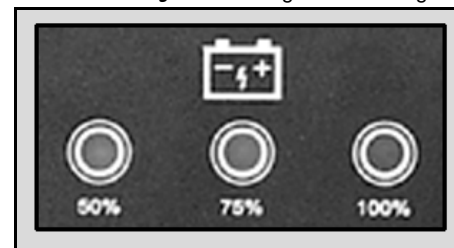

NOTE: The battery charger circuit must be used with a GFI (Ground Fault Interrupt) outlet.
DO NOT operate the machine while the charger is plugged in.

INSPECTION AND MAINTENANCE SCHEDULE

The Complete Inspection consists of periodic visual and operational checks, along with periodic minor adjustments that assure proper performance. Daily inspection will prevent abnormal wear and prolong the life of all systems. The inspection and maintenance schedule should be performed at the specified intervals. Inspection and maintenance shall be performed by personnel who are trained and familiar with mechanical and electrical procedures.

⚠ WARNING ⚠

Before performing preventative maintenance, familiarize yourself with the operation of the machine.

Always block the elevating assembly whenever it is necessary to perform maintenance while the platform is elevated.

The daily preventative maintenance checklist has been designed for machine service and maintenance. Please photocopy the Daily Preventative Maintenance Checklist and use the checklist when inspecting the machine.

DAILY PREVENTATIVE MAINTENANCE CHECKLIST

MAINTENANCE TABLE KEY

Y = Yes/Acceptable

N = No/Not Acceptable

R = Repaired/Acceptable

PREVENTATIVE MAINTENANCE REPORT

Date: _____

Owner: _____

Model No: _____

Serial No: _____

Serviced By: _____

COMPONENT	INSPECTION OR SERVICES	Y	N	R
Battery	Check electrolyte level.			
	Check battery cable condition.			
Chassis	Check hoses for pinch or rubbing points.			
	Check welds for cracks.			
Control Cable	Check the exterior of the cable for pinching, binding or wear.			
Controller	Check switch operation.			
Drive Motors	Check for operation and leaks.			
Elevating Assembly	Inspect for structural cracks.			
Emergency Hydraulic System	Operate the emergency lowering valve and check for serviceability.			

COMPONENT	INSPECTION OR SERVICES	Y	N	R
Entire Unit	Check for and repair collision damage.			
Hydraulic Fluid	Check fluid level.			
Hydraulic Pump	Check for hose fitting leaks.			
Hydraulic System	Check for leaks.			
Labels	Check for peeling, missing, or unreadable labels & replace.			
Platform Deck and Rails	Check welds for cracks.			
Platform Deck and Rails	Check condition of deck.			
Tires	Check for damage.			

LABELS

These labels shall be present and in good condition before operating the machine. Be sure to read, understand and follow these labels when operating the machine.

Figure 13: Safety Label Locations | Serial # M30176 - M30338

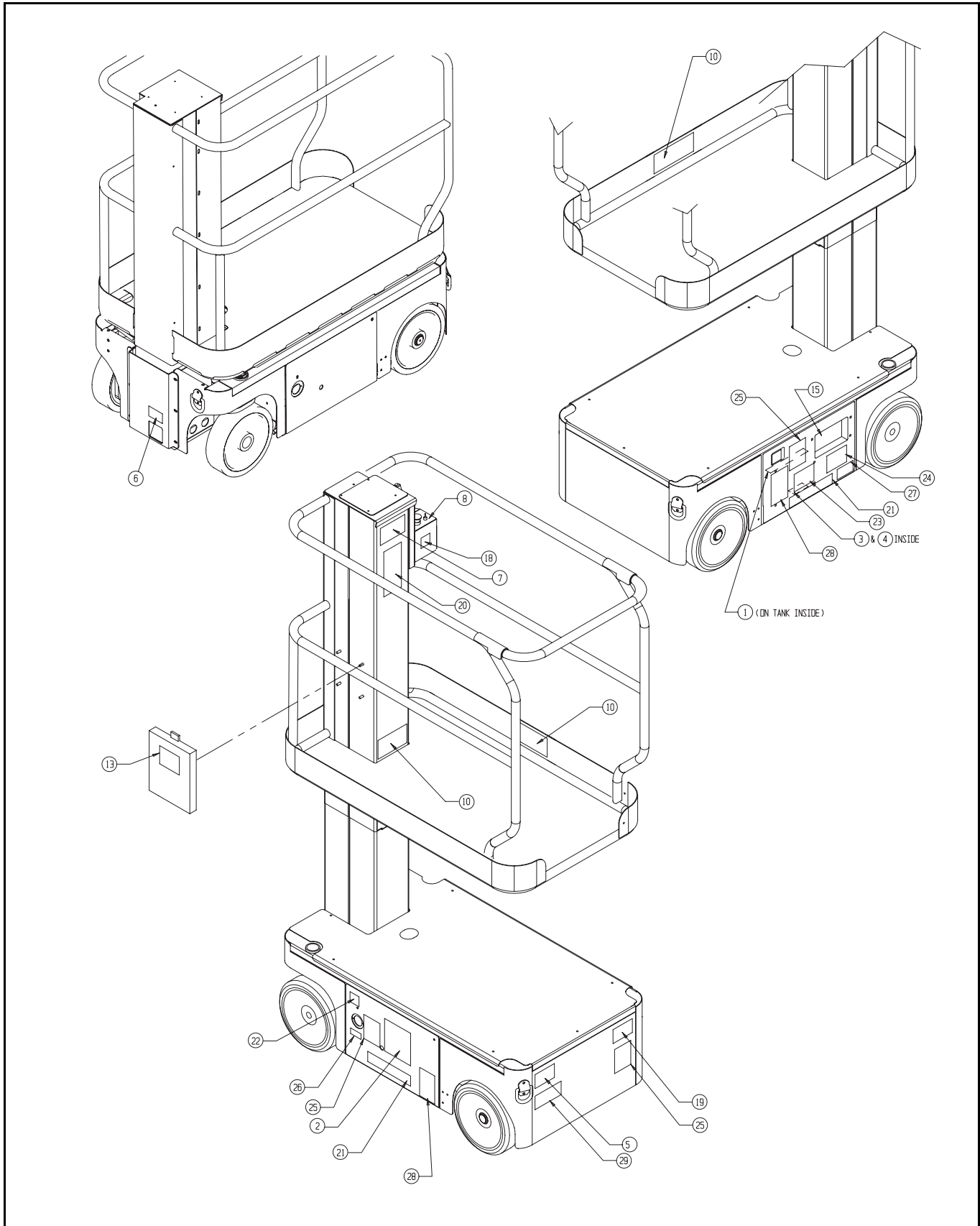

Figure 14: Safety Labels | Serial # M30176 - M30338

1 060197-000

HYDRAULIC FLUID

10 101250-000

WARNING
MAXIMUM DISTRIBUTED PLATFORM LOAD 500 LBS. OR 2 OCCUPANTS
MAXIMUM SIDE LOAD 100 LBS.

23 066555-000

CAUTION
 Limitations, pressure switches, level sensors and relief valves are adjusted at the factory.
 Proper adjustment is required for safe operation.
DO NOT adjust without consulting UpRight.

2 066552-000

WARNING
 Exploding gas is generated when charging batteries.
DO NOT expose to sparks or flames.

13 010076-001

ATTENTION
Safety Rules & Operating Instructions Enclosed

24 066568-000

WARNING
 CRUSHING HAZARD
 KEEP CLEAR OF PLATFORM
 LOWER PLATFORM COMPLETELY BEFORE SERVICING MACHINE

3 061205-005

UpRight
 Model _____ Serial number: _____
 GVW _____ lbs. Mfg. date: _____
 Occupants and equipment must not exceed the rated workload _____ lbs. Rated number of occupants: _____
 Maximum platform height: _____ ft.
 Nominal System Voltage: _____ vdc
 Maximum wheel and/or outrigger load: _____ lbs.
 This machine is manufactured to comply with ANSI A92.6-1999.
CAUTION: CONSULT OPERATOR'S MANUAL BEFORE USE. THIS PLATFORM IS NOT ELECTRICALLY INSULATED.
 061205-005

15 065568-001

EMERGENCY STOP
 UP
 DOWN
 CHASSIS OFF
 DECK OFF
 CIRCUIT BREAKER

25 066556-000

CAUTION
 Collision hazard.
 Impact from descending platform may cause injury. Stand clear.
 66556-000

5 005221-000

BATTERY
 MAINTAIN BATTERY FLUID AT RECOMMENDED LEVEL

19 062562-001

DANGER
 TIP-OVER HAZARD
 BATTERIES ACT AS COUNTERWEIGHT
 EACH REPLACEMENT BATTERY SHALL WEIGH 60 LBS OR MORE

26 066522-000

BATTERY CHARGER

6 005223-005

EMERGENCY DOWN VALVE
 PULL KNOB TO LOWER PLATFORM

7 066554-000

CAUTION
 BEFORE operating this equipment, read, understand and then follow all safety information in instruction manual.

20 066550-001

DANGER
 Failure to read, understand, and obey the following safety rules will cause death or serious injury.
TIP-OVER HAZARDS
 • DO NOT operate on uneven, sloped or soft ground.
 • DO NOT drive into holes or over drive shafts.
ELECTROCUTION HAZARD
 • DO NOT operate within ten feet of power lines. THIS MACHINE IS NOT INSULATED.
 • Look up, down and around for electrical wires.
FALL HAZARD
 • DO NOT climb on platform.
 • Make sure guardrails are fastened securely.
 • Secure gates or chain across entrance.
 • DO NOT use ladders or scaffolding on platform.
 • DO NOT climb down rear.

27 101252-000

MAXIMUM WHEEL LOAD 675 LBS.

8 107050-000

FORWARD UP
NEUTRAL
DOWN REVERSE
UpRight
 LIFT DRIVE
EMERGENCY STOP

21 014222-003-99

MEETS OR EXCEEDS THE REQUIREMENTS OF ANSI A92.6-1999

28 066556-001

WARNING
 CRUSHING HAZARD
 Keep all body parts away.

29 107051-000

BATTERY DISCONNECT LOCATED INSIDE
 USE DISCONNECT BEFORE SERVICING WORK PLATFORM OR BATTERIES

22 061220-002

FORK-LIFT HERE FOR TRANSPORTING ONLY

Figure 15: Safety Label Locations - European ITT | Serial # M30339 - M30642

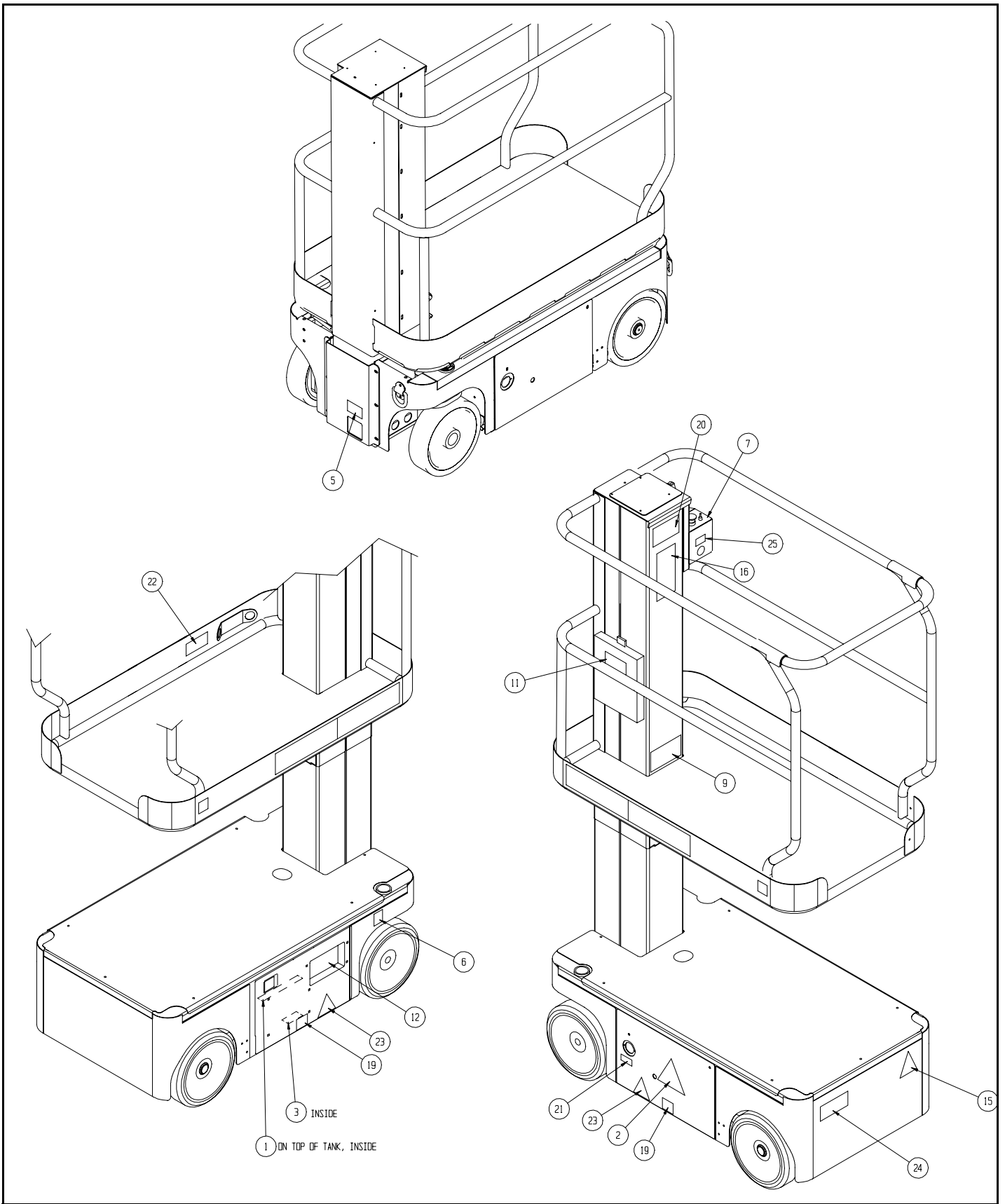



Figure 16: Safety Labels - European ITT | Serial # M30339 - M30642

HYDRAULIC FLUID

1 060197-001



2 101210-000

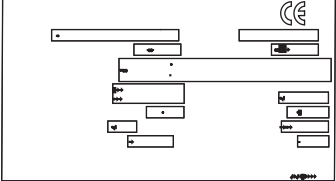

3 505049-000

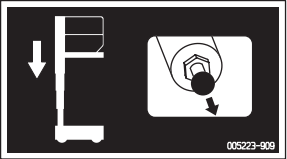

5 005223-909

11 010076-901



12 505079-000

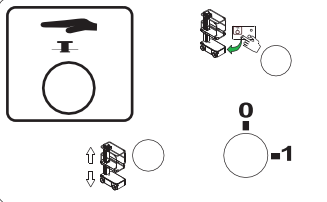

15 062562-951

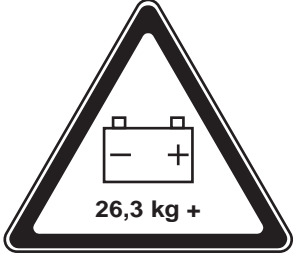

20 100102-900

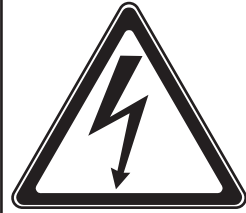

21 066522-900

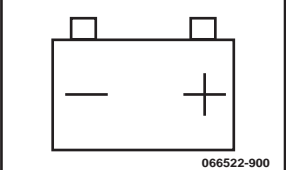

22 068635-001

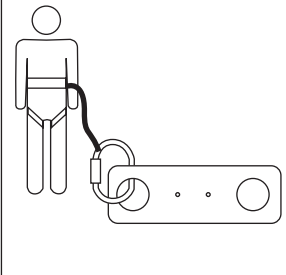

UpRight TM12

6 505077-000

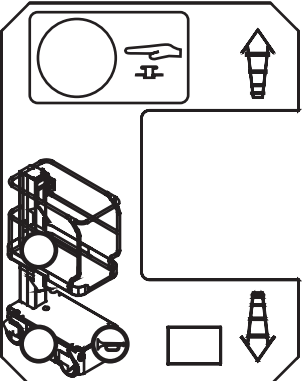

7 505078-000

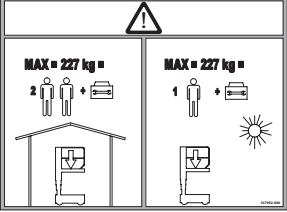

9 107052-000

16 505076-000

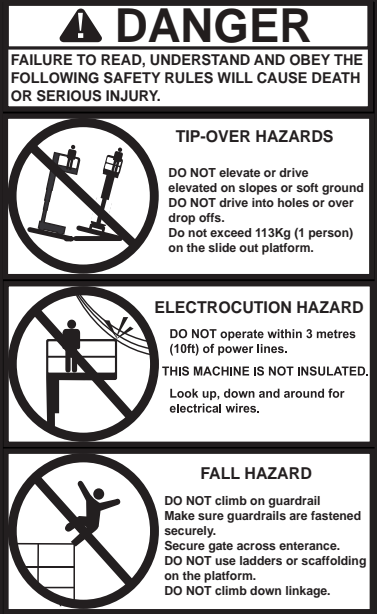

19 014222-903

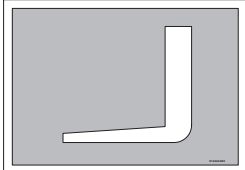

23 501453-000



24 503723-000

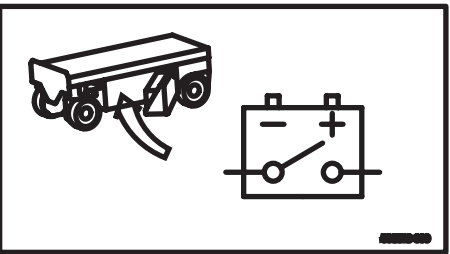

25 107053-000

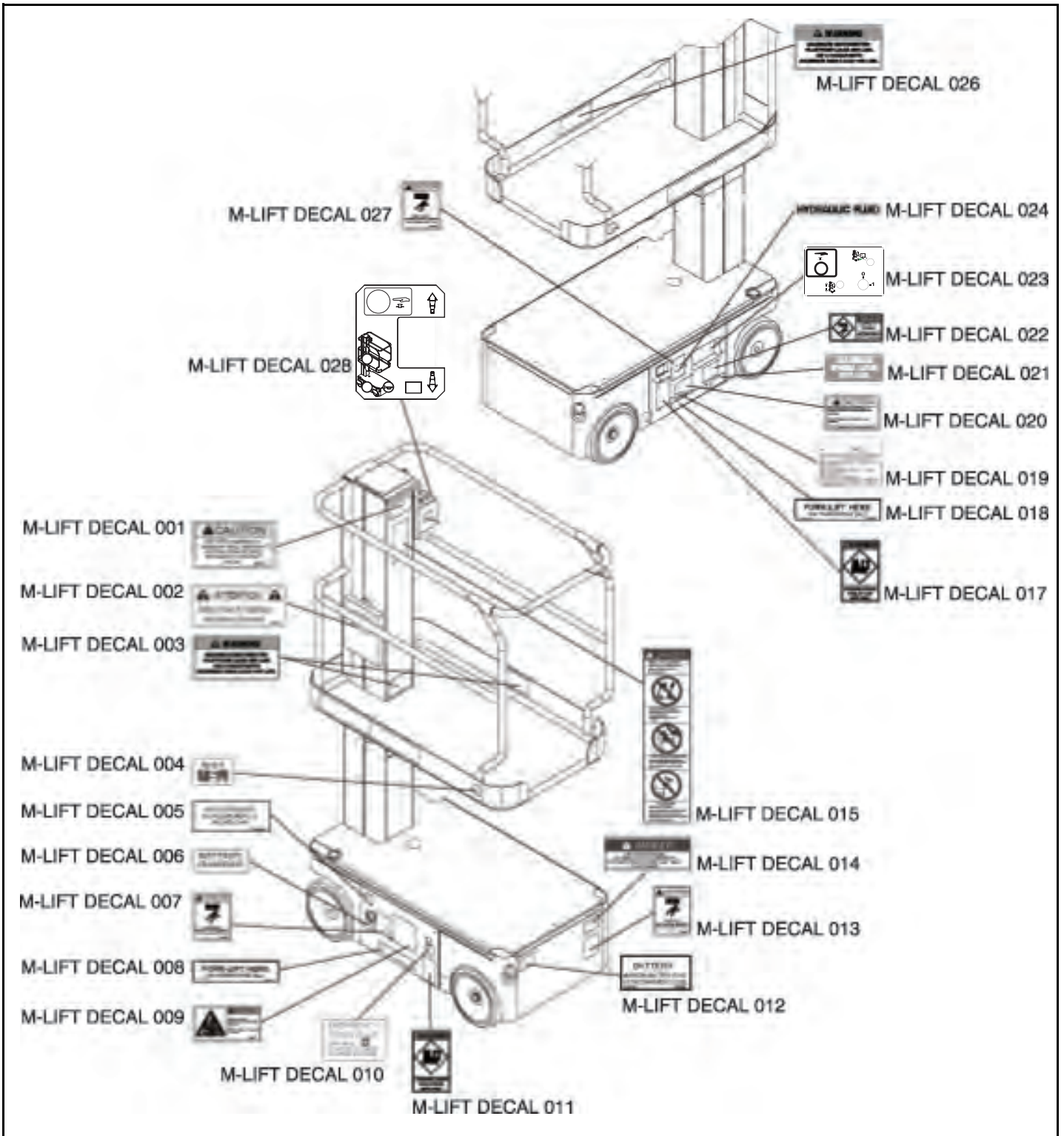

Figure 17: Safety Labels Locations - Domestic ITT | Serial # M30339 - M30642



SPECIFICATIONS

ITEM	Ui12M
Platform Size	73,7 cm x 1,04 m (29 in. x 41 in.)
Maximum Platform Capacity	227 kg (500 lbs.)
Maximum Number of Occupants	2 People indoors/1 person outdoors
Height	
Working Height	5,83 m (19 ft.)
Maximum Platform Height	3,83 m (12.5 ft.)
Minimum Platform Height	48,3 cm (19 in.)
Dimensions	
Weight	776 kg (1710 lbs.)
Overall Width	76 cm (30 in.)
Overall Height	165 cm (65 in.)
Overall Length	1,36 m (53.5 in.)
Drive Speed	
Platform Lowered	3,65 km/h (2.27 mph)
Platform Raised	0,87 km/h (0.54 mph)
Energy Source	24V battery pack Four 220 ampere hour, 6 Volt batteries, min. wt. 26,3 kg (58 lbs.) each 4 HP DC electric motor
System Voltage	24 VDC
Battery Charger	18 AMP, 115 / 230V, 50/60Hz
Battery Duty Cycle	25% for 8 Hours
Hydraulic Reservoir Capacity	7,2 L (1.9 gal)
Maximum Hydraulic System Pressure	165 bar (2400 psi)
Hydraulic Fluid	
Normal above 32° F [0° C]	ISO #46
Low Temp. below 32° F [0° C]	ISO #32
below 0° F [-17° C]	ISO #15
Lift System	One Single Stage Lift Cylinder
Drive Control	Proportional
Control System	Proportional Control Handle with Interlock, Selector Switch, Red Mushroom Emergency Stop Switches
Horizontal Drive	Dual Front Wheel
Tires	30,5 cm (12 in.) diameter solid rubber, Non-marking
Parking Brakes	Dual, Spring Applied, Hydraulic Release
Turning Radius	37 cm (14.5 in.) Inside
Maximum Gradeability	14° (25%)
Wheel Base	97,8 cm (38.5 in.)
Guardrails	1,10 m (43 in.)
Toeboard	152 mm (6 in.)
Noise Level	

*Specifications are subject to change without notice. Hot weather or heavy use may affect performance.

Refer to the Service Manual for complete parts and service information.

This machine meets or exceeds ANSI A92.6 1999 directive requirements.

NOTES:

GENERAL INFORMATION

This section contains generic instructions for the repair and maintenance of UpRight Aerial Work Platforms. Referring to the Operator Manual will aid in understanding the operation and function of the various components and systems of the machine, and help in diagnosing and repair of the machine.

TABLE OF CONTENTS

1-1	Hazard Indicators	1-2
1-2	Workshop Procedures	1-2
1-3	Torque Specifications	1-3
1-4	Date Code Identification on Hoses	1-5
1-5	Special Tools	1-5
1-6	UpRight Connectors	1-6
1-7	Hydraulic Manifold Repair	1-8
1-8	Cylinder Repair	1-9
1-9	Electric Motors	1-10
1-10	Battery Maintenance	1-12
1-11	Floor Loading	1-16
1-12	Hydraulic Fluid	1-17
1-13	Long Term Storage	1-18

LIST OF FIGURES

Figure 1-1:	UpRight Connector Kits	1-6
Figure 1-2:	UpRight Male Connector	1-6
Figure 1-3:	UpRight Female Connector	1-6
Figure 1-4:	Locking Finger, UpRight Connector	1-7
Figure 1-5:	Heavy Duty UpRight Connector	1-7
Figure 1-6:	Electric Motor Service	1-10
Figure 1-7:	Electric Motor Brushes	1-11
Figure 1-8:	Contact Area	1-16
Figure 1-9:	Occupied Surface Area	1-16

LIST OF TABLES

Table 1-1:	Torque Specifications for Hydraulic Components	1-3
Table 1-2:	Torque Specifications for SAE Fasteners	1-3
Table 1-3:	Torque Specifications for Metric Fasteners, U.S. Customary Units	1-4
Table 1-4:	Torque Specifications for Metric Fasteners, SI Units	1-4
Table 1-5:	Specific Gravity and Battery Voltage	1-13
Table 1-6:	Battery Charging, UpRight Electric and BiEnergy Machines	1-14
Table 1-7:	Battery Charger Troubleshooting	1-15

1-1 HAZARD INDICATORS

⚠ DANGER ⚠

Indicates an imminently hazardous situation which, if not avoided, will result in death or serious injury.

⚠ WARNING ⚠

Indicates a potentially hazardous situation which, if not avoided, could result in death or serious injury.

⚠ CAUTION ⚠

Indicates a potentially hazardous situation which, if not avoided, may result in minor or moderate injury.

CAUTION

Indicates a potentially hazardous situation which, if not avoided, may result in damage to the machine.

1-2 WORKSHOP PROCEDURES

Detailed descriptions of standard workshop procedures, safety principles and service operations are not included. Please note that this manual does contain warnings and cautions against some specific service methods which could cause personal injury, or could damage a machine or make it unsafe. Please understand that these warnings cannot cover all conceivable ways in which service, whether or not recommended by UpRight, Inc., might be done, or of the possible hazardous consequences of each conceivable way, nor could UpRight Inc. investigate all such ways. Anyone using service procedures or tools, whether or not recommended by UpRight Inc., must satisfy themselves thoroughly that neither personal safety nor machine safety will be jeopardized.

⚠ WARNING ⚠

Be sure to read, understand and follow all safety rules, operating instructions, and the Scaffold Industry Association's MANUAL OF RESPONSIBILITIES of ANSI A92.6-1999 before performing maintenance on or operating any UpRight Aerial Work Platform.

⚠ WARNING ⚠

Never perform service on the machine in the elevating assembly area while platform is elevated without first blocking the elevating assembly.

DO NOT stand in elevating assembly area while deploying or storing brace.

Refer to the Operator Manual for elevating assembly blocking instructions.

1-3 TORQUE SPECIFICATIONS

HYDRAULIC COMPONENTS

NOTE: Always lubricate threads with clean hydraulic fluid prior to installation

Use the following values to torque hydraulic components used on UpRight Aerial Work Platforms.

Table 1-1: Torque Specifications for Hydraulic Components

Type: SAE Port Series	Cartridge Poppet		Fittings		Hoses	
	Ft/Lbs	Nm	Ft/Lbs	Nm	In/Lbs	Nm
#4	N/A	N/A	N/A	N/A	135-145	15-16
#6	N/A	N/A	10-20	14-27	215-245	24-28
#8	25-30	34-41	25-30	34-41	430-470	49-53
#10	35-40	47-54	35-40	47-54	680-750	77-85
#12	85-90	115-122	85-90	115-122	950-1050	107-119
#16	130-140	176-190	130-140	176-190	1300-1368	147-155

FASTENERS

This standard applies to the preloading of fasteners measured by installation torque.

NOTE: For other preloading methods or fasteners consult UpRight Engineering Department.

This general standard applies to all SAE and Metric fasteners unless otherwise specified.

THREAD CONDITION

- For lubricated or zinc plated fasteners use $K = .15$
- For dry unplated fasteners use $K = .20$

TORQUE TABLES

Table 1-2: Torque Specifications for SAE Fasteners

	Nominal Thread Size	SAE J429 Grade 5			SAE J429 Grade 8		
		Clamp Load	Tightening Torque		Clamp Load	Tightening Torque	
			K=,15	K=,20		K=,15	K=,20
		lbs.	in-lbs.	in-lbs.	lbs.	in-lbs.	in-lbs.
Unified Coarse Thread Series	1/4 -20	2,000	75	100	2850	107	143
	5/16 - 18	3,350	157	210	4700	220	305
		lbs.	ft-lbs.	ft-lbs.	lbs.	ft-lbs.	ft-lbs.
	3/8-16	4,950	23	31	6950	32.5	44
	7/16-14	6,800	37	50	9600	53	70
	1/2-13	9,050	57	75	12800	80	107
	9/16-12	11,600	82	109	16400	115	154
	5/8-11	14,500	113	151	20300	159	211
	3/4-10	21,300	200	266	30100	282	376
	7/8-9	29,435	321	430	41550	454	606
1-8	38,600	483	640	54540	680	900	
	Nominal Thread Size	Clamp Load	Tightening Torque		Clamp Load	Tightening Torque	
			K=,15	K=,20		K=,15	K=,20
		lbs.	in-lbs.	in-lbs.	lbs.	in-lbs.	in-lbs.
Unified Fine Thread Series	1/4 -28	2,300	85	115	3250	120	163
	5/16-24	3,700	173	230	5200	245	325
		lbs.	ft-lbs.	ft-lbs.	lbs.	ft-lbs.	ft-lbs.
	3/8-24	5,600	26	35	7900	37	50
	7/16-20	7,550	42	55	10700	59	78
	1/2-20	10,200	64	85	14400	90	120
	9/16-18	13,000	92	122	18300	129	172
	5/8-18	16,300	128	170	23000	180	240
	3/4-16	23,800	223	298	33600	315	420
	7/8-14	32,480	355	473	45855	500	668
1-12	42,270	528	704	59670	745	995	

Table 1-3: Torque Specifications for Metric Fasteners, U.S. Customary Units



Nominal Thread Size	 Grade 8.8			 Grade 10.9			 Grade 12.9		
	Clamp Load	Tightening Torque		Clamp Load	Tightening Torque		Clamp Load	Tightening Torque	
		K =,15	K =,20		K =,15	K =,20		K =,15	K =,20
mm	lbs.	in-lbs.	in-lbs.	lbs.	in-lbs.	in-lbs.	lbs.	in-lbs.	in-lbs.
3	-	-	-	-	-	-	823	14.6	19.5
3.5	-	-	-	-	-	-	1,109	22.9	30.5
4	-	-	-	-	-	-	1,436	33.9	45.2
5	1,389	41.0	54.7	1,987	58.7	78.2	2,322	68.6	91.2
6	1,966	69.7	92.9	2,813	100.0	132.8	3,287	116.8	155.8
7	2,826	116.8	155.8	4,044	167.3	223.0	4,727	195.6	260.2
		ft-lbs.	ft-lbs.		ft-lbs.	ft-lbs.		ft-lbs.	ft-lbs.
8	3,579	14.1	18.8	5,122	20.1	26.9	5,986	23.6	31.4
10	11,742	27.9	37.2	8,117	39.9	53.3	9,486	46.7	62.3
12	8,244	48.7	64.9	11,797	69.7	92.2	13,787	81.1	108.4
14	11,246	77.4	103.3	16,093	110.6	147.5	18,808	129.1	172.6
16	15,883	125.4	166.7	21,971	173.3	230.9	25,677	202.1	269.2
18	19,424	171.9	229.4	26,869	238.2	317.2	31,401	278.1	371.0
20	2,304	243.4	325.3	34,286	337.8	449.9	40,070	394.6	525.9
22	30,653	331.9	442.5	42,403	458.8	612.2	49,556	536.2	715.4
24	35,711	420.4	562.0	49,400	583.4	778.1	57,733	682.2	909.4
27	46,435	617.3	84.8	64,235	853.4	1138.1	75,069	997.2	1329.8
30	56,753	837.9	1117.4	78,509	1159.4	1545.2	91,751	1354.9	1807.0
33	70,208	1140.3	1520.1	97,121	1576.9	2102.8	113,503	1843.9	2457.5
36	82,651	1464.1	1952.3	114,334	2025.3	2700.9	133,620	2367.6	3156.0

Table 1-4: Torque Specifications for Metric Fasteners, SI Units

Nominal Thread Size	 Grade 8.8			 Grade 10.9			 Grade 12.9		
	Clamp Load	Tightening Torque		Clamp Load	Tightening Torque		Clamp Load	Tightening Torque	
		K =,15	K =,20		K =,15	K =,20		K =,15	K =,20
mm	N	N-m	N-m	N	N-m	N-m	N	N-m	N-m
3	-	-	-	-	-	-	3660	1.65	2.2
3.5	-	-	-	-	-	-	4932	2.59	3.45
4	-	-	-	-	-	-	6387	3.83	5.11
5	6177	4.63	6.18	8840	6.63	8.84	10330	7.75	10.3
6	8743	7.87	10.5	12512	11.3	15	14623	13.2	17.6
7	12570	13.2	17.6	17990	18.9	25.2	21025	22.1	29.4
8	15921	19.1	25.5	22784	27.3	36.5	26626	32	42.6
10	52230	37.8	50.5	36105	54.1	72.2	42195	63.3	84.4
12	36670	66	88	52475	94.5	125	61328	110	147
14	50025	105	140	71587	150	200	83663	175	234
16	70650	170	226	97732	235	313	114218	274	365
18	86400	233	311	119520	323	430	139680	377	503
20	10250	330	441	152513	458	610	178238	535	713
22	136350	450	600	188618	622	830	220433	727	970
24	158850	570	762	219743	791	1055	256808	925	1233
27	206550	837	115	285728	1157	1543	333923	1352	1803
30	252450	1136	1515	349223	1572	2095	408128	1837	2450
33	312300	1546	2061	432015	2138	2851	504885	2500	3332
36	367650	1985	2647	508582	2746	3662	594368	3210	4279

1-4 DATE CODE IDENTIFICATION ON HOSES

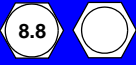
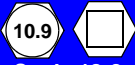
GATES uses an eight digit code: Plant, Month, Day, Year.
i.e.: XX 01 07 01 - means Plant XX January 07 2001.

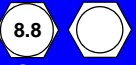
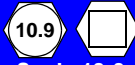
PARKER uses a 4 digit code indicating Quarter and Year.
i.e.: 2Q01 - means Second Quarter of 2001.

DAYCO stamps month, day and year on each hose.

1-5 SPECIAL TOOLS

The following is a list of special tools which may be required to perform certain maintenance procedures on the machine.

- 0-69 bar (**0-1000 psi**) Hydraulic Pressure Gauge with Adapter Fittings
- 0-207 bar (**0-3000 psi**) Hydraulic Pressure Gauge with Adapter Fittings
- 0-414 bar (**0-6000 psi**) Hydraulic Pressure Gauge with Adapter Fittings
- Small UpRight Connector Field Kit (UpRight P/N 030899-000)
- Large UpRight Connector Field Kit (UpRight P/N 030898-000)
- Inclinometer (UpRight P/N 010199-000-00)
- MOS90 Calibrator (UpRight P/N 057128-000)
- Optimizer with adapter (UpRight P/N 100329-000)
- Flow Meter Kit (UpRight P/N 067040-000)
- Quadrageauge with fitting (UpRight P/N 063971-000)
- 0-25 kg (**0-50 Lbs.**) Chain Tension Scale (UpRight P/N 107078-000)

UPRIGHT LIFT TOOL LIST

- Gland Nut Wrench (UpRight P/N 062521-000)
- Strap Wrench (UpRight P/N 062482-000)
- Tierod Tensioner (2 required) (UpRight P/N 062738-000)
- Tensioner Bracket (2 required) (UpRight P/N 062739-000)

1-6 UPRIGHT CONNECTORS

UpRight connectors are designed so that connector parts, contacts or electrical cables may be replaced without replacing the entire connector.

Figure 1-1: UpRight Connector Kits

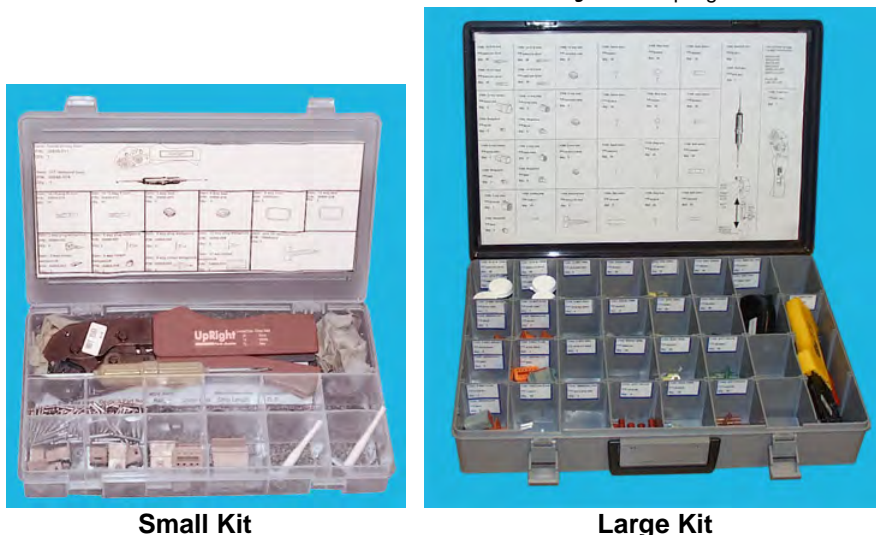

Small Kit

Large Kit

MALE CONNECTOR (PLUG)

1. Disconnect the male connector (plug) from the female connector (receptacle).
2. Using the flat end of the Removal Tool (or flat blade screwdriver), pry the Locking Wedge from the Male Connector. Care should be taken that the Sealing Gasket is not damaged during this procedure.
3. Check all parts for damage. Replace all parts which are damaged or worn.
4. Replace or re-crimp the wires and contacts. Refer to "Crimping" procedure.

Figure 1-2: UpRight Male Connector

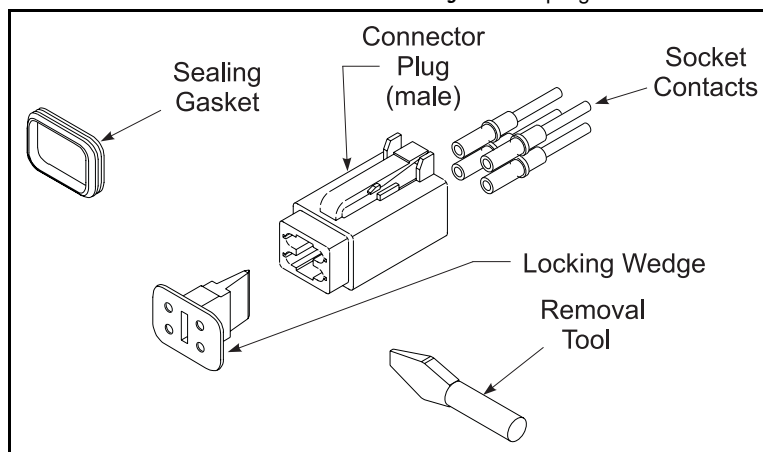

FEMALE CONNECTOR (RECEPTACLE)

1. Disconnect the male connector (plug) from the female connector (receptacle).
2. Using the notched end of the Removal Tool (or a wire hook), pull the Locking Wedge from the Female Connector.
3. Check all parts for damage. Replace all parts which are damaged or worn.
4. Replace or re-crimp the wires and contacts. Refer to "Crimping" procedure.

Figure 1-3: UpRight Female Connector

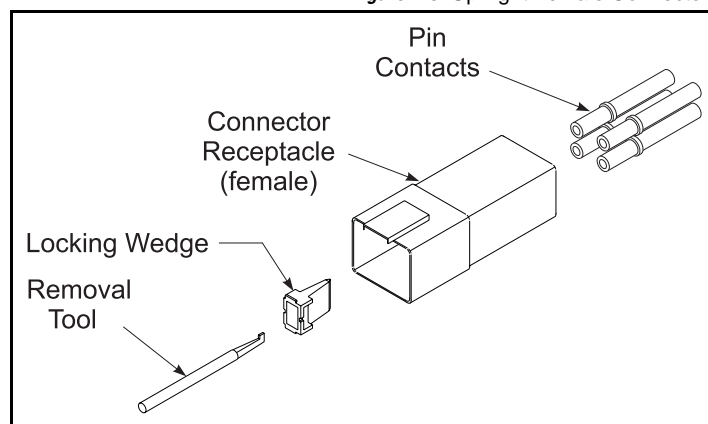

RELEASING LOCKING FINGERS

1. The Locking Fingers can be released following the removal of the Locking Wedge of either the male or female connector.
2. Use the removal tool (or flat bladed screwdriver) to push the Locking Fingers aside. This will release the grip on the contact.
3. Pull the wire and contact out of the connector.

Figure 1-4: Locking Finger, UpRight Connector

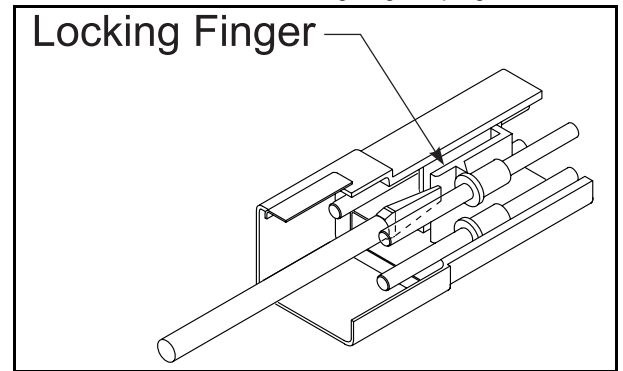

CRIMPING

1. Strip 6 mm ($\frac{1}{4}$ in.) from the wire.

NOTE: Complete crimping instructions are included in each Field Kit.

2. Insert the contact into the crimping tool.
3. Insert the stripped wire into the contact. Copper strands should be visible in the bleed hole of the contact and no copper strands should be loose (outside) of the contact barrel.
4. Completely close the handles of the crimping tool. Release the handles of the crimping tool and remove the crimped contact.
5. Inspect the crimped contact to ensure that all strands are secure in the crimp barrel.

REMOVING CONTACT FROM HEAVY DUTY PLUG

Figure 1-5: Heavy Duty UpRight Connector

1. Slip the removal tool along the wire to be replaced.
2. Push the removal tool into the connector until the contact is released.
3. Pull the wire and contact out of the plug.

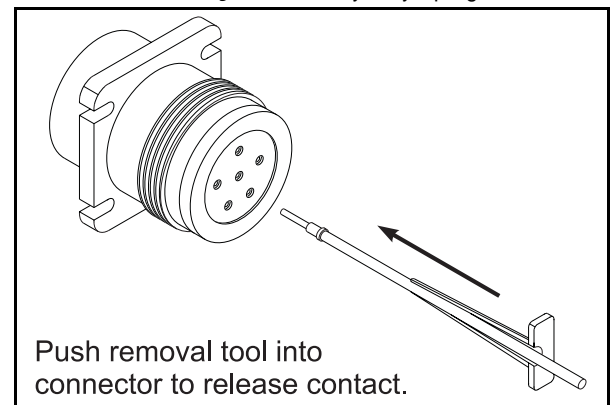

1-7 HYDRAULIC MANIFOLD REPAIR

REMOVAL

Refer to the *Service and Repair* section for model specific information.

1. Disconnect the battery.
2. Tag and disconnect the solenoid valve leads.
3. Tag, disconnect, and plug hydraulic hoses.
4. Remove the bolts that hold the manifold to the mounting bracket.
5. Remove the manifold block.

DISASSEMBLY

NOTE: Mark all components as they are removed so as not to confuse their location during assembly.

1. Remove coils from solenoid valves.
2. Remove valves.
3. Remove fittings, plugs, springs, balls, and orifices.

CLEANING AND INSPECTION

1. Wash the manifold in cleaning solvent to remove built-up contaminants, then blow out all passages with clean compressed air.
2. Inspect the manifold for cracks, thread damage and scoring where O-rings seal against internal and external surfaces.
3. Wash and dry each component and check for thread damage, torn or cracked O-rings, and proper operation.
4. Replace parts and O-rings found unserviceable.

ASSEMBLY

Refer to the *Service and Repair* section for assembly drawings, and the *Parts Manual* for illustrated parts breakdowns.

NOTE: Lubricate all O-rings before installation to prevent damage to O-rings. Seat all balls in manifold block by lightly tapping on the ball with a brass drift punch.

1. Install fittings, plugs, springs, balls, and orifices. Use one drop of Loctite #242 on each screw-in orifice.
2. Install valves.

INSTALLATION

Refer to the *Service and Repair* section for model specific information.

1. Attach manifold assembly to mounting plate with bolts.
2. Connect solenoid leads (as previously tagged).
3. Connect hydraulic hoses. Be certain to tighten hoses to manifold.
4. Reconnect the battery.
5. Operate each hydraulic function and check for proper operation and leaks.
6. Adjust valve pressures according to the *Service and Repair* section.

1-8 CYLINDER REPAIR

⚠ WARNING ⚠

Cylinders may be very heavy. Support heavy cylinders before removing pins which secure the cylinder to the machine.

REMOVAL

NOTE: Refer to the *Service and Repair* section for the location of cylinders, and the *Parts Manual* for a list of parts which secure the cylinders.

1. Mark and disconnect hoses and IMMEDIATELY cap the openings to prevent contamination.
2. Remove the cylinder from the machine as described in the *Service and Repair* section.

DISASSEMBLY

1. Remove the head from the cylinder body.
2. Carefully slide the rod assembly out of the cylinder.
3. Remove the seal kit components (wipers, rod seals, o-rings and backup rings) from the head and piston.
4. Inspect parts for scratches, pits or polishing. Check seal grooves and sealing surfaces. Scratches or pits deep enough to catch the fingernail are unacceptable; replace the cylinder. Polishing is a sign of uneven loading. When this occurs, the surface should be checked for roundness. Cylinders not round within 0,18 mm (.007 in.) should be replaced.

ASSEMBLY

Refer to the *Service and Repair* section for seal-kit assembly drawings, and the *Parts Manual* for illustrated parts breakdowns.

NOTE:

- To avoid cutting the seals, do not use sharp edged tools during seal replacement. After installing seals allow at least one hour for the seals to elastically restore to their original shape before assembling the cylinder.
- Torque all hardware to torques according to Table 1-1, "Torque Specifications for Hydraulic Components," on Page 1-3 unless otherwise specified.

1. Lubricate all components with clean hydraulic fluid.
2. Install new seal kit components.
3. Lubricate the rod wiper and seal with hydraulic fluid and slide the head onto the rod.
4. Lubricate the seals on the piston and head.
5. Carefully slide the rod assembly into the cylinder.
6. Secure the head into the cylinder.

INSTALLATION

1. Installation is reverse of removal.
2. Carefully remove the elevating assembly support.
3. Slowly cycle the cylinder several times to remove air from the hydraulic system.
4. Check for proper cylinder operation. Check hydraulic connections for leaks.

1-9 ELECTRIC MOTORS

TROUBLESHOOTING

1. Read the nameplate to become familiar with the motor, especially the rated voltage.
2. Try to turn the shaft by hand. Keep motor leads separated while doing this. If the shaft turns freely go to Step 3. If the shaft won't turn, proceed to Step A.
 - A. The shaft could be tight for a number of reasons, this check is to determine if the tightness is of a temporary nature only.
 - a. Obtain power to produce the nameplate voltage. **Do not Make a Permanent Connection.**
 - b. First touch the motor leads quickly to the power supply just long enough to observe if the shaft turns.
 - c. If it does turn, then hold the motor leads on the power supply for a longer time. If the motor sounds normal, go to Step 3..
 - d. If the motor sounds noisy, it should be taken apart as described in the disassembly section.
3. If the motor turned freely, connect an ammeter in the circuit as shown in Figure 1-6A. With rated voltage applied and the shaft running free, the ammeter should read less than 20% of the nameplate full load current. If the motor meets the above conditions, then it can be assumed that the original problem is external to the motor.

Figure 1-6: Electric Motor Service

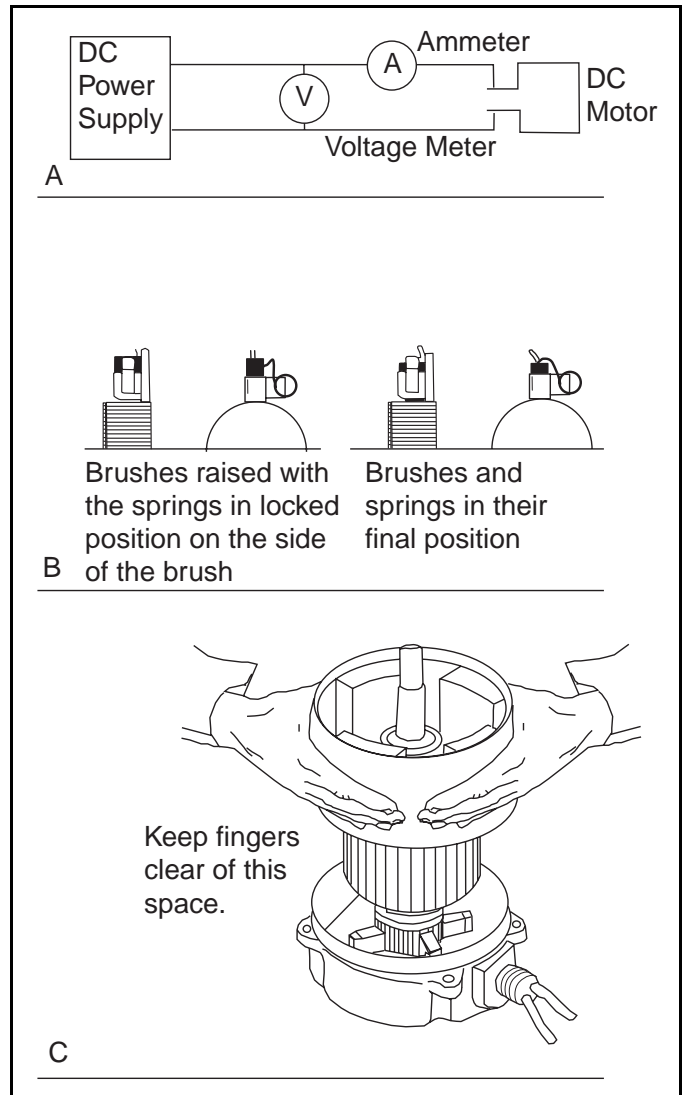

DISASSEMBLY

1. Remove the through bolts.
2. Remove the pulley end cover.
3. Pull the armature out of the assembly in one swift motion.
4. Remove the commutator end cover.

NOTE: Do not place the stator ring in any mechanical holding device during the disassembly or assembly operation. Permanent distortion or other damage will result.

INSPECTION

Once the motor has been disassembled, go through the following check-list steps to determine where the problem lies.

1. Bearings should spin smoothly and easily and have ample lubrication and be free of corrosion.
2. The armature should be checked for grounds and shorted turns. Re-finish the commutator surface if it is pitted or excessively worn. (This procedure should be performed by a qualified electric motor shop.)
3. Brushes should be checked for wear and to ensure that they are free in the brush holders.

NOTE: Observe how the brushes are assembled in the brush holders, and the position of the brush lead. New brushes must be installed in the same manner. Brushes should be removed as follows:

- a. Remove the brush spring clip from its mounting on the brush assembly.
 - b. Lift the brush assembly from the brush holder.
 - c. Disconnect the brush assembly lead.
 - d. Install the new brush assembly by reversing the above procedure.
4. Inspect the wire harness and all connections for signs of damage due to overheating.
 5. Check the stator to see if it is securely mounted.

REASSEMBLY

1. Install new brushes and be sure they are free in the holder. Install the brush with the lead wires positioned as when received. Raise all brushes to the locked position. (See Figure 1-7 and **Inspection** Step 3.).
2. Place the commutator cover on a work bench with the brush assembly facing upward.
3. Place the bearing spring into the bearing bore.
4. Take a complete armature assembly, including bearings, and insert the commutator end bearing into the bearing bore.

NOTE: Do not re-use bearings which have been removed from the armature shaft. Keep the assembly in a vertical position. Use extreme care not to damage the armature with bearing pullers. New bearings should be installed by pressing the inner race of the bearing onto proper position on the armature shaft.

5. Set the brushes into their final position as shown in Figure 1-7.
6. Place the complete stator down over the vertical armature, and into position on the commutator cover.
7. The stator assembly must be placed in a definite relationship with the commutator covers in order to obtain a neutral brush setting. There is a match-mark on both items. These two marks must line up exactly. Rotate until they do.
8. Assemble the pulley end cover in the proper relationship. Insert the mounting bolts and tighten alternately to ensure a good mechanical alignment.
9. Spin the shaft by hand to see if it is free. Be sure motor leads (if used) are not touching together. If the leads are touching, a generator action will give the effect of friction in the motor. A no-load test can now be performed. At the rated voltage, observe the no-load current. It should be less than 20% of the name-plate full load current. Anything higher indicates:
 - Brushes are not on neutral setting (check match-marks for exact alignment).
 - Faulty armature.

Figure 1-7: Electric Motor Brushes

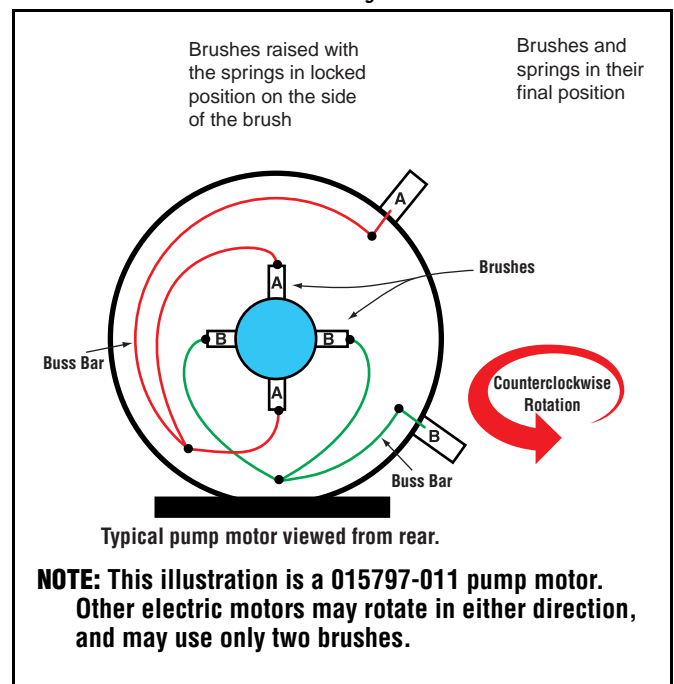

1-10 BATTERY MAINTENANCE

CAUTION

If battery water level is not maintained, batteries will not fully charge, creating a low discharge rate.

⚠ WARNING ⚠

Hazard of explosive gas mixture. Keep sparks, flame and smoking materials away from batteries.

Always wear safety glasses when working with batteries.

Battery fluid is highly corrosive. Thoroughly rinse away any spilled fluid with clean water.

Always replace batteries with UpRight batteries or manufacturer approved replacements.

Before disconnecting the battery negative (-) lead, make sure all switches are OFF. If ON, a spark will occur at the ground terminal which could cause an explosion if hydrogen gas or fuel vapors are present.

- Check battery fluid level daily.
- If electrolyte level is lower than 10 mm (**3/8 in.**) above plates, add distilled water only. DO NOT use tap water with high mineral content. It will shorten battery life. DO NOT overfill. Battery acid expands during charging and can overflow.
- Keep terminals and tops of batteries clean.
- The battery and cables should be inspected regularly for signs of cracks in the case, electrolyte leakage and corrosion of the terminals. Inspect the cables for worn spots or breaks in the insulation and for broken cable terminals.
- Clean batteries whenever there are signs of corrosion at the terminals, or when electrolyte has overflowed during charging. Use a baking soda solution to clean batteries, taking care not to get the solution inside the cells. Rinse thoroughly with clean water.
- Clean battery and cable contact surfaces to a bright metal finish whenever a cable is removed.

BATTERY CHECK

Electric UpRight Aerial Work Platforms use deep cycle batteries. If poor service life is experienced, batteries should be checked for bad cells. Fully charge batteries for 14 hours minimum, ensuring that the charger has completed its cycle (see 'Battery Charging' on page 1-14).

Deep cycle batteries do not have their full potential until they have been through 50 charge/discharge cycles. Normal 5-day weeks, charging batteries every day, equals 50 cycles in ten weeks.

If bad cells are found in any battery in a battery pack more than two years old, all batteries in the pack should be replaced for balance.

BATTERY CELL EQUALIZATION

The specific gravity of the electrolyte in the battery cells should be equalized monthly. To do this, charge batteries as outlined in 'Battery Charging' on page 1-14. After this initial charge, recheck the electrolyte level in all cells and add distilled water as necessary. Then, turn on the charger for an additional eight hours.

SPECIFIC GRAVITY

Check the specific gravity of all cells with a hydrometer. The temperature corrected specific gravity of a fully charged battery should be 1.260. If any corrected readings are below 1.230, the batteries containing such cells should be replaced.

Do not check the specific gravity in a cell to which water has just been added. If there is not enough electrolyte in a fully charged cell to obtain a sample for the hydrometer, add water and complete a discharge/charge cycle before checking.

Table 1-5: Specific Gravity and Battery Voltage

	SPECIFIC GRAVITY		VOLTS DC			
	Each Cell	Per Cell	6V Battery	12V Battery	24V Battery Pack	48V Battery Pack
Fully Charged	1.270	2.10	6.30	12.60	25.20	50.40
Fully Discharged	1.130	1.75	5.25	10.50	21	42

LOAD TESTING BATTERY PACKS

1. Fully charge the battery pack.
2. With the battery pack at rest and under full load, perform steps 3 and 4.
 - a. To put the battery pack under full load,
 - Activate the steering switch to turn the wheels fully in either direction.
 - Continue to hold the steering switch while performing steps 3 and 4.
3. Measure the potential across each battery.
4. Measure the potential across the entire battery pack.
5. Compare the measured results

Any battery that measures 10% lower voltage than the others has a bad cell and should be replaced.

BATTERY CHARGING

CAUTION

Permanent damage will result if the battery is not immediately recharged after discharging.

WARNING

Charge batteries only in a well ventilated area.

DO NOT charge batteries when sparks or open flames are present.

Never leave the connected charger unattended for more than two days.

Never disconnect the cables from the battery when the charger is operating.

Keep the charger dry.







- Charge batteries at the end of each work shift or sooner if the batteries have been discharged.
- Discharging a deep cycle battery to less than 1.75 Volts per cell can cause permanent damage.

NOTE: Do not operate the machine when the battery charger is plugged in.

When night temperatures fall below 65°F (18°C), batteries charged in unheated areas should be charged as soon after use as possible. Under such conditions a four hour charge cycle once a week in the early afternoon will improve the state of charge and battery life.

1. Check the battery fluid level. If electrolyte level is lower than 10 mm (3/8 in.) above plates, add distilled water only.
2. Check the charger to determine the AC charging current. If equipped, set the AC voltage selector switch to match the AC power source.
3. Connect an extension cord that meets or exceeds the charger AC current onto the charger plug.
4. Connect the other end of the extension cord to a grounded AC outlet of proper current, voltage and frequency rating.
5. The charger turns on automatically after a short delay. Table 1-6 illustrates charging indicators.

Table 1-6: Battery Charging, UpRight Electric and BiEnergy Machines

Charger Display	AC Charging Current		Charging Indicator	Charger Shutdown											
	068574-000	8 Amp - 115 VAC	Ammeter • Charging current is displayed on ammeter. • Current drops off as batteries charge.	• Charger shuts off automatically. • Ammeter shows "0" current.											
	069112-000	4 Amp - 230 VAC				063944-001	7 Amp - 115 VAC	Green Light • ON during charging cycle. • Blinking at charge completion.	• Charger automatically shuts down to 1 amp trickle charge. • Green Light continues to blink.	063948-003	4 Amp - 230 VAC		069199-000 & 069199-001	8 Amp - 115 VAC 4 Amp - 230 VAC	Three Lights • 0 - 50% charge: First Light -Blinking- Second and Third Light -OFF- • 50% - 75% Charge: First Light -ON- Second Light -Blinking- Third Light -OFF- • 75% - 100% Charge: First and Second Light -ON- Third Light - Blinking- • Charge Complete All Lights -ON-
	063944-001	7 Amp - 115 VAC	Green Light • ON during charging cycle. • Blinking at charge completion.	• Charger automatically shuts down to 1 amp trickle charge. • Green Light continues to blink.											
	063948-003	4 Amp - 230 VAC				069199-000 & 069199-001	8 Amp - 115 VAC 4 Amp - 230 VAC	Three Lights • 0 - 50% charge: First Light -Blinking- Second and Third Light -OFF- • 50% - 75% Charge: First Light -ON- Second Light -Blinking- Third Light -OFF- • 75% - 100% Charge: First and Second Light -ON- Third Light - Blinking- • Charge Complete All Lights -ON-	• Charger automatically shuts down to low current after charging is complete and all Lights turn ON. • Charger continues at low current (equalizing charge) for 3-4 hours, then charging current shuts off completely. • Lights remain ON until the AC power supply is disconnected.	Dual Voltage					
	069199-000 & 069199-001	8 Amp - 115 VAC 4 Amp - 230 VAC	Three Lights • 0 - 50% charge: First Light -Blinking- Second and Third Light -OFF- • 50% - 75% Charge: First Light -ON- Second Light -Blinking- Third Light -OFF- • 75% - 100% Charge: First and Second Light -ON- Third Light - Blinking- • Charge Complete All Lights -ON-	• Charger automatically shuts down to low current after charging is complete and all Lights turn ON. • Charger continues at low current (equalizing charge) for 3-4 hours, then charging current shuts off completely. • Lights remain ON until the AC power supply is disconnected.											
	Dual Voltage														

BATTERY CHARGER TROUBLESHOOTING

CAUTION

Ensure that battery chargers with voltage selector switches are set on the correct AC line voltage before placing chargers in service to avoid charger failure.

Connect battery leads in correct polarity to avoid charger damage.

WARNING



Remove all power before working on electrical parts to avoid shock.

Shock hazard can exist if AC plugs are wired incorrectly.

The battery charger troubleshooting procedure is outlined in Table 1-7. The table shows various conditions for each charger type with the problem to be investigated. Follow the table from the top down when troubleshooting. If the problem is not resolved after going through the entire table, the charger should be replaced.

NOTE: The majority of chargers returned to UpRight as “failed” test good. Please follow the troubleshooting procedures carefully.

Table 1-7: Battery Charger Troubleshooting

				
Problem	068574-000 (115V) 069112-000 (110/230V)	063944-001 (115V) 063948-003 (110/230V)	069199-000 & 069199-001 (115/230V auto)	Solution
Battery voltage is below 18 Volts (too low to allow the charger to turn on).	<ul style="list-style-type: none"> • Ammeter does not move. • No hum from charger. 	<ul style="list-style-type: none"> • No green Light. • No hum from charger. 	<ul style="list-style-type: none"> • Not Applicable. • Charger turns on even with very low battery voltage. 	Charge batteries to at least 24 Volts with an external charger, then disconnect the external charger and plug in the internal charger.
The charger has been plugged into an AC outlet with different voltage than the AC switch setting on the charger.	<ul style="list-style-type: none"> • Ammeter does not move. • No hum from charger. 	<ul style="list-style-type: none"> • No green Light. • No hum from charger. 	<ul style="list-style-type: none"> • Not Applicable. • Charger automatically adjusts to the incoming AC current. 	063944-001 ONLY <ul style="list-style-type: none"> • Check the fuse inside the switch box - replace if bad. • If the fuse is good, the charger has failed. All Others <ul style="list-style-type: none"> • Check the AC main circuit breaker and reset if necessary. • Set the voltage selector switch to the proper voltage.
Fuse visible on front of charger has failed.	<ul style="list-style-type: none"> • Ammeter does not move. • No hum from charger. 	<ul style="list-style-type: none"> • Not Applicable. 	<ul style="list-style-type: none"> • Not Applicable. 	Check for DC output short circuit and replace the fuse.
AC power problem.	<ul style="list-style-type: none"> • Ammeter does not move. • No hum from charger. 	<ul style="list-style-type: none"> • No green Light. • No hum from charger. 	<ul style="list-style-type: none"> • No Lights ON. • No Lights blinking. 	<ul style="list-style-type: none"> • AC outlet is bad. • Extension cord is bad • Plug is bad or wired wrong. • AC wire is broken. Check and repair as necessary.
DC connection to batteries.	<ul style="list-style-type: none"> • Ammeter does not move. • No hum from charger. 	<ul style="list-style-type: none"> • No green Light. • No hum from charger. 	<ul style="list-style-type: none"> • All three Lights blink once. 	Connection to battery; <ul style="list-style-type: none"> • missing. • corroded. • wrong polarity. • DC wire broken. Check and repair as necessary, and check Fuse.
One or more batteries is bad.	<ul style="list-style-type: none"> • Ammeter never shuts off, even after 14 hours of charging. 	<ul style="list-style-type: none"> • Green Light ON but never starts blinking, even after 14 hours of charging. 	<ul style="list-style-type: none"> • Lights one and two are ON or blinking, but all three Lights ON never occurs, even after 14 hours of charging. 	<ul style="list-style-type: none"> • Check water level. • Check for shorted cells. • Replace bad batteries.
AC input voltage too high.	<ul style="list-style-type: none"> • Not Applicable. 	<ul style="list-style-type: none"> • Not Applicable. 	<ul style="list-style-type: none"> • All three Lights blink two times. 	Check and correct AC source.
Overheated charger.	<ul style="list-style-type: none"> • Not Applicable. 	<ul style="list-style-type: none"> • Not Applicable. 	<ul style="list-style-type: none"> • All three Lights blink three times. 	Move the machine to a cooler area. Allow the machine to cool before connecting to AC source.
High current in DC charging output.	<ul style="list-style-type: none"> • Not Applicable. 	<ul style="list-style-type: none"> • Not Applicable. 	<ul style="list-style-type: none"> • All three Lights blink four times. 	<ul style="list-style-type: none"> • Check for shorted DC output wires. • Check for bad batteries.

1-11 FLOOR LOADING

Floor Loading is defined as pressure imposed onto load-bearing surfaces, and can be measured as **Localized Pressure** or **Occupied Pressure**. To calculate Floor Loading, find the Total Weight of the machine.

TOTAL WEIGHT = MACHINE WEIGHT + MAXIMUM PLATFORM CAPACITY.

Refer to the machine specifications or contact UpRight or your UpRight dealer.

LOCALIZED PRESSURE

KG/CM² (PSI)

Localized Pressure is measured in *kilograms per square centimeter (pounds per square inch)*. It is the pressure exerted onto a small area (contact area). Each tire and/or outrigger imposes Localized Pressure which can cause damage to the load-bearing surface.

NOTE: The formulas shown here are for vertical lift machines. Applying these formulas to machines with extending platforms will yield average pressures for machines in stowed position. Extending a platform causes increased localized pressure in the direction of extension, and decreased localized pressure at the opposite end.

MEASURE THE CONTACT AREA

Measure the contact area of the contacting surface (tire or outrigger).

The tire contact area can be determined by placing the loaded tire on a clean surface. The tire will leave an imprint from which an area can be determined.

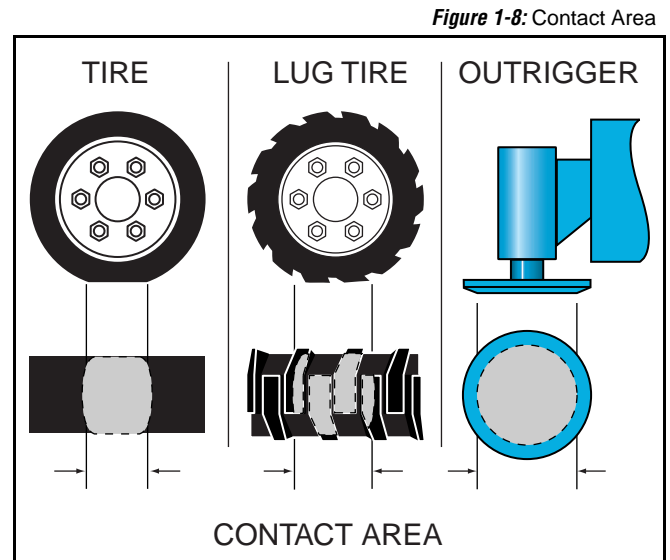

Figure 1-8: Contact Area

CALCULATE THE LOCALIZED PRESSURE

Find the pressure exerted at each contacting surface.

NOTE: The wheel load can usually be found on a label on the machine, or on the serial plate.

If you know the wheel load, use this formula:

LOCALIZED PRESSURE = WHEEL LOAD ÷ CONTACT AREA

If you do not know the wheel load, use this formula:

LOCALIZED PRESSURE = (TOTAL WEIGHT ÷ 4) ÷ CONTACT AREA

OCCUPIED PRESSURE

BAR (PSF)

Occupied Pressure is measured in *bar (pounds per square foot)*. It is the total pressure imposed onto the work surface over the area of the machine (occupied surface area). This is especially important when the work surface is supported by beams. The Occupied Pressure *must not exceed* the maximum load that the surface can support.

OCCUPIED PRESSURE = TOTAL WEIGHT ÷ (LENGTH X WIDTH)

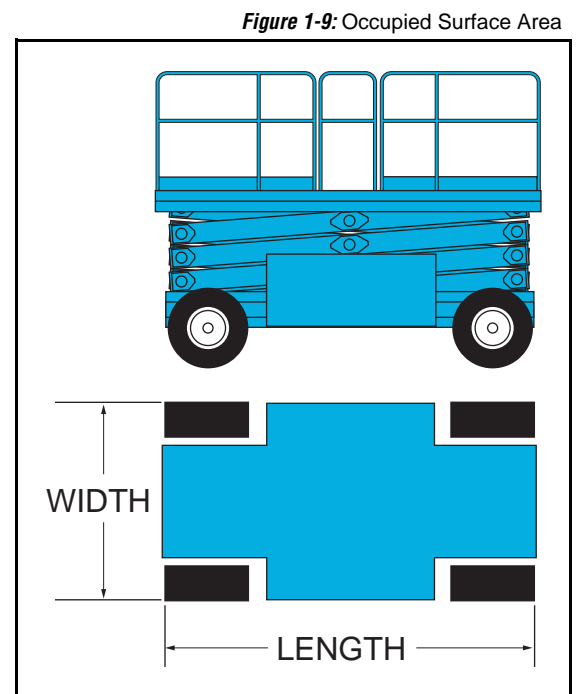

Figure 1-9: Occupied Surface Area

1-12 HYDRAULIC FLUID

FLUID LEVEL

With the platform fully lowered, check the hydraulic fluid level. If the fluid is NOT in operating range, add hydraulic fluid until the fluid level is in operating range.

- DO NOT fill above operating range.
- DO NOT add fluid when the platform is elevated.

RECOMMENDED HYDRAULIC FLUID

CAUTION

Unless recommended by UpRight, do not mix hydraulic fluids of different brands or types. The required additives and fluid viscosities may vary.

If the use of hydraulic fluids other than listed below is desired please contact UpRight Product Support.

MOBILFLUID 424

- Viscosity Grade: ISO 46 High V.I. (similar to SAE 10W-30).
- Viscosity index: 152.
- Operating Range: -10° C to +96° C (+15° F to +205° F) Reservoir Temperature.
- Ambient Conditions*: Above -10° C (+15° F).

MOBIL DTE 13 M

- Viscosity Grade: ISO 32 High V.I. (similar to SAE 5W-20).
- Viscosity index: 140.
- Operating Range: -18° C to +80° C (-4° F to +176° F) Reservoir Temperature.
- Ambient Conditions*: -18° C to +30° C (-4° F to +86° F).

MOBIL DTE 11 M

- Viscosity Grade: ISO 15.
- Viscosity index: 140.
- Operating Range: -35° C to +45° C (-30° F to +115° F) Reservoir Temperature.
- Ambient Conditions*: -35° C to +20° C (-30° F to +70° F).

MOBIL EAL ENVIROSYN 46 H

For use where a *biodegradable non-toxic hydraulic fluid is required.*

- Viscosity Grade: ISO 46 High V.I. (similar to SAE 10W-20).
- Viscosity Index: 153.
- Operating Range: -14° C to +90° C (+6° F to +195° F) Reservoir Temperature.
- Ambient Conditions*: -14° C to +41° C (+6° F to +105° F).
- Synthetic Ester Base.

The anti-wear quality of hydraulic fluid must meet or exceed API Service Classification GL-3. The chemical stability of the hydraulic fluid must be sufficient for mobile hydraulic system service.

*Ambient Conditions are for reference only and may vary by model. Refer to operating temperature for final determination of correct fluid.

1-13 LONG TERM STORAGE

NOTE: Do not drain the hydraulic system prior to long term storage.

If the machine is to be placed in long term storage, follow these recommended preservation procedures.

PRESERVATION

1. Clean painted surfaces. If paint is damaged, repaint.
2. Fill the hydraulic reservoir to operating level.

IMPORTANT: Do not fill the hydraulic reservoir while the platform is elevated.

3. Coat exposed portions of cylinder rods with a preservative such as multipurpose grease and wrap with a barrier material.
4. Coat all exposed unpainted metal surfaces with preservative.
5. **Internal Combustion Models:** Service the engine according to the manufacturers recommendations.
6. **Electric And BiEnergy Models:** Remove the batteries and place them in alternative service.

SERVICE AND REPAIR

This section contains instructions for the maintenance of the Work Platform. Refer to the General Information section for information relevant to all UpRight work platforms. Referring to the Operator Manual will aid in understanding the operation and function of the various components and systems of the work platform, and help in diagnosing and repair of the machine.

⚠ WARNING ⚠

Be sure to read, understand and follow all information in the Operation Section of this manual before attempting to operate or perform service on any Work Platform.

⚠ DANGER ⚠

*Never perform service on the work platform in the elevating assembly area while platform is elevated without first blocking the elevating assembly.
DO NOT stand in elevating assembly area while deploying or storing brace.*

IMPORTANT

**UI 12 M-Lifts and TM12 Machines with Serial Number range of
———— M30176 through M30642 ————**

have the possibilities of two different:

- Motor Control Systems
- Wire harnesses
- Hydraulic Valve Blocks
- Upper Control Box
- Lower control Box

Assure that you are looking at the correct drawings before you order parts. These components are broken apart by numbers.

TABLE OF CONTENTS

2-1 Supporting Elevating Assembly 2-3
Installation 2-3
Removal 2-3

2-2 Preventative Maintenance 2-4

2-3 Preventative Maintenance Check List 2-5

2-4 Parts Location 2-6

2-5 General Lubrication 2-8

2-6 Batteries 2-9
Battery Replacement 2-9
Battery Maintenance 2-9

2-7 Hydraulics	2-10
Hydraulic Oil Tank And Filter	2-10
Hydraulic Pump	2-11
Cylinder valve Assembly	2-12
Main Hydraulic Manifold	2-13
Setting Hydraulic Manifold Pressures	2-15
2-8 Cylinders	2-17
Depression Cylinder	2-17
Brake Cylinder	2-18
Steering Cylinder	2-19
Lift Cylinder	2-20
2-9 Drive Motors	2-21
Removal	2-21
Installation	2-21
2-10 Elevating Assembly	2-22
Lift Chain Lubrication	2-23
Elevating Assembly Wear Inspection	2-23
Chain Tension Inspection	2-24
Chain Elongation Inspection	2-24
Removal of Elevating Assembly	2-25
Installation of Elevating Assembly	2-25
2-11 Tilt Sensor	2-26
2-12 Controls	2-27
Platform Controls	2-27
Chassis Controls	2-29
2-13 Motor Controller and I/O Board Dip Switch Settings Serial # M30176 — M30338	2-30
Controller	2-30
I/O (Circuit) Board	2-30

LIST OF FIGURES

Figure 2-1: Supporting Elevating Assembly	2-3
Figure 2-2: Parts Location Serial # M30176 — M30338	2-6
Figure 2-3: Parts Location - ITT Serial # M30179 — M30642	2-7
Figure 2-4: Lubrication Points	2-8
Figure 2-5: Battery Cables	2-9
Figure 2-6: Hydraulic Oil Tank and Filter	2-10
Figure 2-7: Hydraulic Pump	2-11
Figure 2-8: Cylinder Valve	2-12
Figure 2-9: Hydraulic Manifold Serial # M30176 — M30338	2-13
Figure 2-10: Hydraulic Manifold Serial # M30339 — M30642	2-14
Figure 2-11: Hydraulic Manifold relief Serial # M30176 — M30338	2-15
Figure 2-12: Hydraulic Manifold Relief Serial # M30339 — M30642	2-15
Figure 2-13: Depression Cylinder Remove & Replace	2-17
Figure 2-14: Brake Cylinder, Remove & Replace	2-18
Figure 2-15: Steering Cylinder Remove & Replace	2-19
Figure 2-16: Brake and Steering Cylinder Seal Kit	2-19
Figure 2-17: Lift Cylinder Seal Kit	2-20
Figure 2-18: Drive Motor Assembly	2-21
Figure 2-19: Elevating Assembly	2-22
Figure 2-20: Chain Elongation Inspection	2-24
Figure 2-21: Tilt Sensor	2-26
Figure 2-22: Upper Controls Serial # M30176 — M30338	2-27
Figure 2-23: Upper Controls Serial # M30339 — M30642	2-28
Figure 2-24: Chassis Controls Serial # M30176 — M30338	2-29
Figure 2-25: Chassis Controls Serial # M30339 — M30642	2-29
Figure 2-26: Controller	2-30
Figure 2-27: I/O Board	2-30

2-1 SUPPORTING ELEVATING ASSEMBLY

⚠ WARNING ⚠

Never perform service on the work platform in the elevating assembly area while platform is elevated without first blocking the elevating assembly.

DO NOT stand in elevating assembly area while deploying or storing brace.

INSTALLATION

1. Park the Work Platform on firm level ground.
2. Verify Platform Emergency Stop Switch is **ON**.
3. Turn Chassis Key Switch to **CHASSIS**.
4. Position Chassis Lift/Lower Switch to **UP** and elevate Platform approximately 1.2m (**4 feet**).
5. Place a wood block, 5cm x 10cm x 46cm (**2 in. x 4 in. x 18 in.**) long between the #2 Mast and Chassis just behind the Mast Assembly.
6. Push Chassis Lift Switch to **DOWN** position and gradually lower Platform until the #2 Mast is supported by the block.

REMOVAL

1. Push Chassis Lift Switch to **UP** position and gradually raise Platform until wood block can be removed.
2. Remove block.
3. Push Chassis Lift Switch to **DOWN** position and completely lower Platform

Figure 2-1: Supporting Elevating Assembly

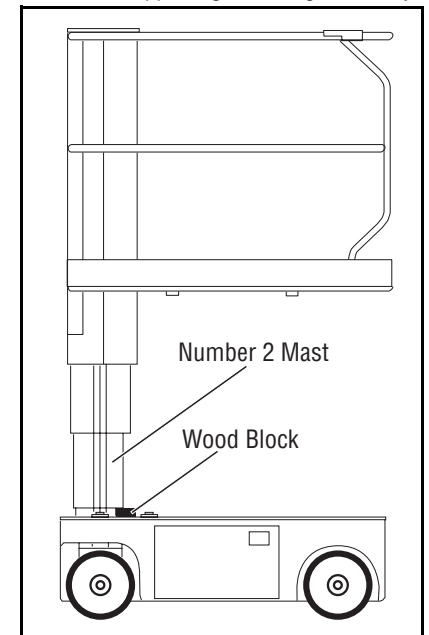

2-2 PREVENTATIVE MAINTENANCE

The complete inspection consists of periodic visual and operational checks, along with periodic minor adjustments to assure proper performance. Daily inspection will prevent abnormal wear and prolong the life of all systems. The inspection and maintenance schedule is to be performed at regular intervals. Inspection and maintenance shall be performed by personnel who are trained and familiar with mechanical and electrical procedures.

! WARNING !

Before performing preventative maintenance, familiarize yourself with the operation of the machine.

Always block the elevating assembly whenever it is necessary to enter the scissor assembly to perform maintenance while the platform is elevated.

The preventative maintenance table has been designed for machine service and maintenance repair. Please photocopy the following page and use the table as a checklist when inspecting the machine for service.

2-3 PREVENTATIVE MAINTENANCE CHECK LIST

PREVENTATIVE MAINTENANCE KEY

Interval

- Daily=each shift or every day
- 50h/30d=every 50 hours or 30 days
- 250h/6m=every 250 hours or 6 months
- 1000h/2y=every 1000 hours or 2 years
- Y=Yes/Acceptable
- N=No/Not Acceptable
- R=Repaired/Acceptable

PREVENTATIVE MAINTENANCE REPORT

Date: _____

Owner: _____

Model No: _____

Serial No: _____

Serviced By: _____

Service Interval: _____

COMPONENT	INSPECTION OR SERVICES	INTERVAL	Y	N	R
Battery System	Check electrolyte level	Daily			
	Check battery cable condition	Daily			
	Charge batteries	Daily			
	Check charger condition & operation	Daily			
	Check specific gravity	6m			
	Clean exterior	6m			
	Clean terminals	6m			
Hydraulic Oil*	Check oil level	Daily			
	Change Filter	6m			
	Drain and replace oil	2y			
Hydraulic System	Check for leaks	Daily			
	Check hose connections	30d			
	Check hoses for exterior wear	30d			
Drive Motors	Check for operation and leaks	Daily			
Emergency Down	Check procedure for Emergency Down	Daily			
Hydraulic Pump	Check for fitting leaks	Daily			
	Wipe clean	30d			
	Check for leaks at mating surfaces	30d			
	Check mounting bolts for proper torque	6m			
Controller	Check condition & operation	Daily			
Platform Deck & Rails	Check fasteners for proper torque	Daily			
	Check welds for cracks	Daily			
	Check condition of deck	Daily			
	Check entry way closure	Daily			

COMPONENT	INSPECTION OR SERVICES	INTERVAL	Y	N	R
Elevating Assembly	Inspect for external damage, dents, loose rivets or cracks	Daily			
	Check chains and sheaves for wear	6m			
	Lubricate lift chains	6m			
	Check chain tension	1yr			
	Remove and inspect chains	5yr			
	Chassis	Check cables for pinch or rubbing points	Daily		
Check welds for cracks		Daily			
Check component mounting for proper torque		6m			
Lift Cylinder	Check for leaks	Daily			
	Check for proper torque	6m			
Entire Unit	Perform pre-operation inspection	Daily			
	Check for and repair collision damage	Daily			
	Lubricate	30d			
	Check fasteners for proper torque	6m			
Labels	Check for corrosion; remove and repaint	6m			
	Check for peeling, missing, or unreadable labels & replace	Daily			
Wheels	Check for loose components	Daily			
Steering System	Oil pivot pins	30d			
	Oil king pins	30d			
	Check steering cylinder for leaks	30d			
	Check hardware & fittings for proper torque	6m			

* NOTE: Use ISO #46 during summer and ISO #32 during winter.

2-4 PARTS LOCATION

Figure 2-2: Parts Location | Serial # M30176 — M30338

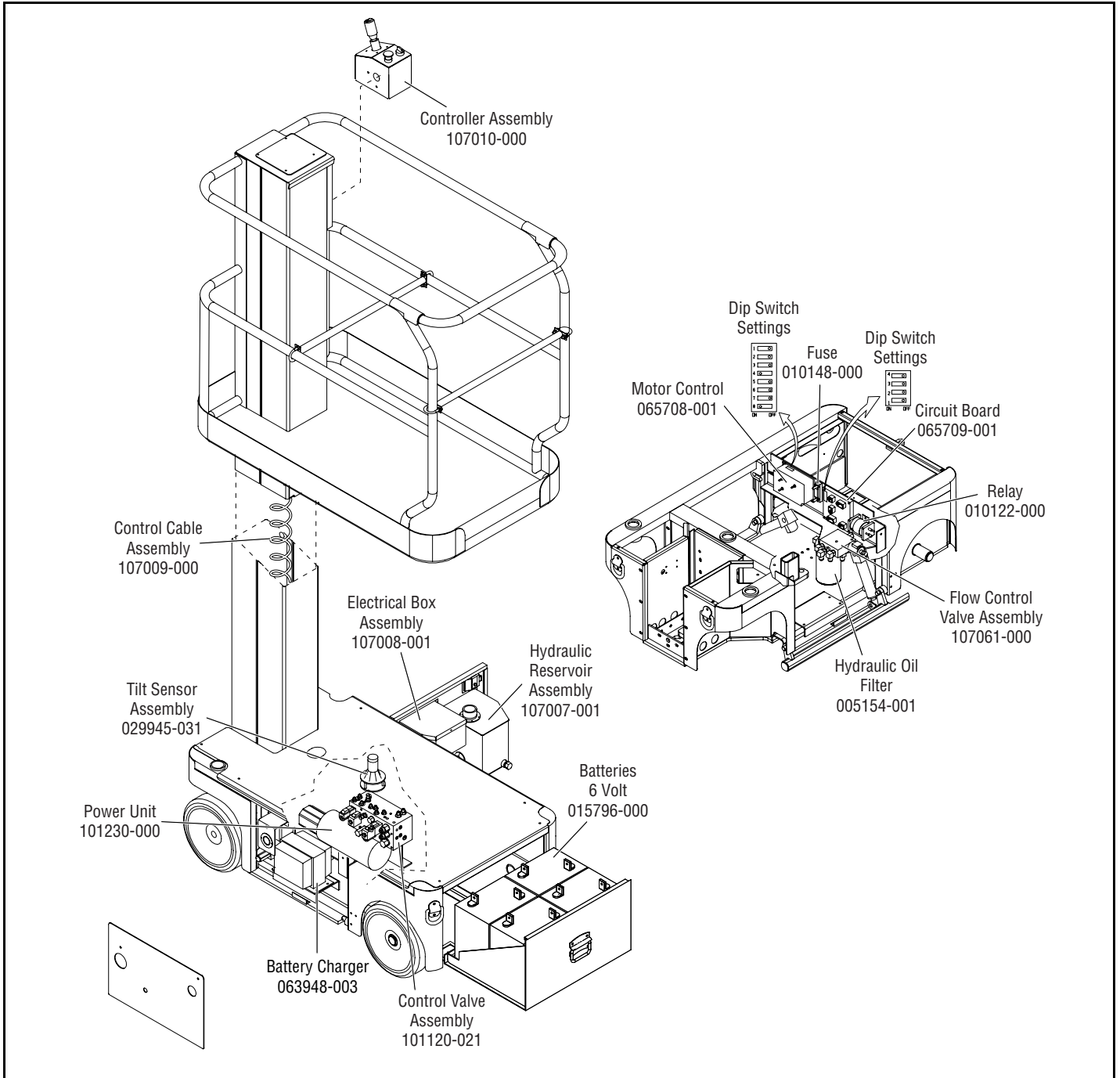
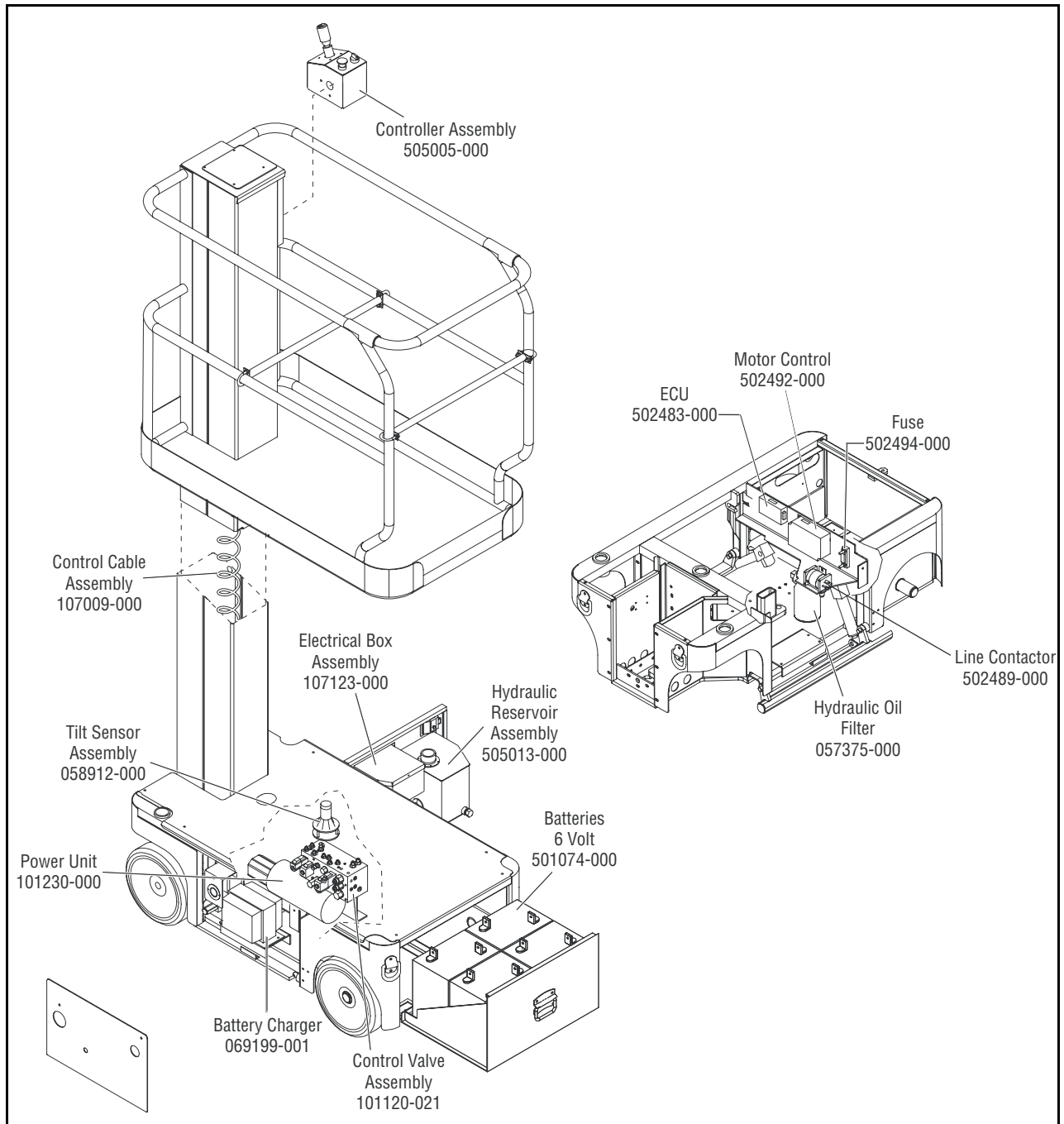

Figure 2-3: Parts Location - ITT | Serial # M30179 — M30642



2-5 GENERAL LUBRICATION

- Apply grease to each grease fitting.
- Apply one or two drops of motor oil to each bearing.

Figure 2-4: Lubrication Points

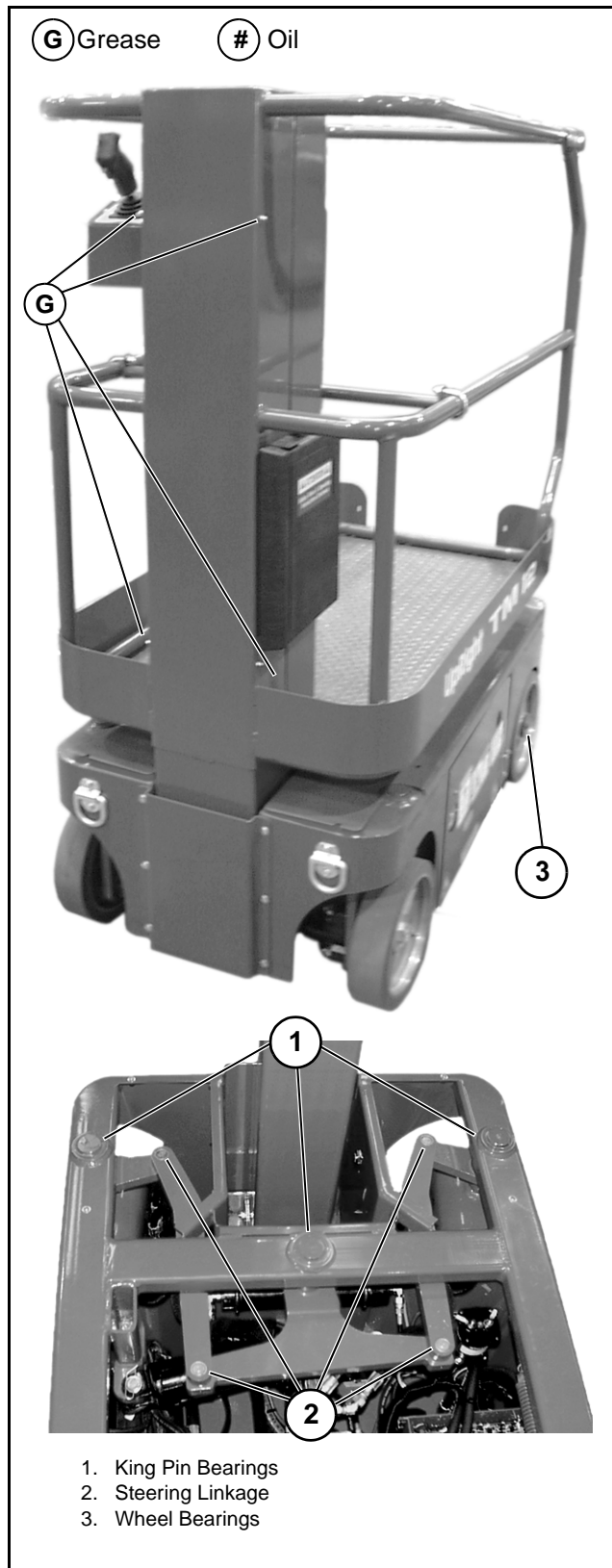

2-6 BATTERIES

Electrical Energy for the motor is supplied by four 6 volt batteries wired in series for 24 volts DC. Proper care and maintenance of the batteries and motor will ensure maximum performance from the work platform.

CAUTION

If battery water level is not maintained, batteries will not fully charge, creating a low discharge rate.

WARNING

Hazard of explosive gas mixture. Keep sparks, flame and smoking materials away from batteries.

Always wear safety glasses when working with batteries.

Battery fluid is highly corrosive. Thoroughly rinse away any spilled fluid with clean water.

Always replace batteries with UpRight batteries or manufacturer approved replacements.

Before disconnecting the battery negative (-) lead, make sure all switches are OFF. If ON, a spark will occur at the ground terminal which could cause an explosion if hydrogen gas or fuel vapors are present.

BATTERY REPLACEMENT

The batteries are located in a slide-out tray in the rear of the machine. There are four 6 volt batteries wired in series for 24 volts DC. Battery cables must be installed as shown in the Battery Cable Installation Diagram.

BATTERY MAINTENANCE

Refer to *Section 1: General Information* for complete battery maintenance instructions.

Refer to the *Operation Manual* included in this Service Manual for specific maintenance and charging instructions.

Figure 2-5: Battery Cables

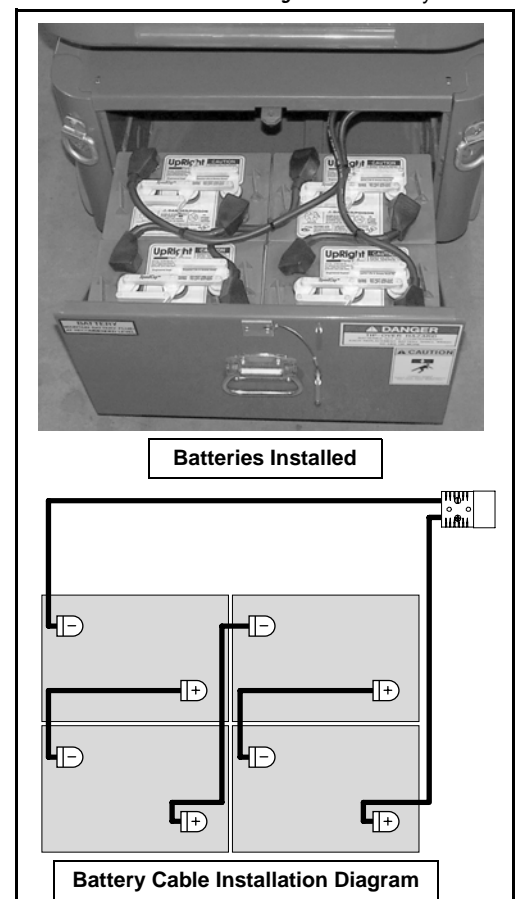

2-7 HYDRAULICS

HYDRAULIC OIL TANK AND FILTER

FLUID LEVEL

With Platform fully lowered, oil should be visible on the dipstick, if not, fill the tank until oil registers on the dipstick. **DO NOT** fill above the lower line on the dipstick or when the Platform is elevated.

OIL AND FILTER REPLACEMENT

1. Operate the work platform for 10-15 minutes to bring the hydraulic oil up to normal operating temperature.
2. Provide a suitable container to catch the drained oil. Hydraulic tank has a 7,2 liter (1.9 US gal.) capacity.
3. Open module door.
4. Remove the magnetic drain plug and allow all oil to drain.
5. Check the magnetic plug for metal fragments.
6. Clean and re-install the drain plug.
7. Un-thread the suction screen from the tank.
8. Wash the suction screen in cleaning solvent and then blow out with clean compressed air.
9. Apply a thin film of clean hydraulic oil (ISO #46) to the threads and re-install the suction screen.
10. Un-thread the filter from the filter head.
11. Apply a thin film of clean hydraulic oil (ISO #46) to the gasket of the replacement filter.
12. Thread the replacement filter onto the filter head until the gasket makes contact, then rotate the filter $\frac{3}{4}$ of a turn further.
13. Fill the hydraulic reservoir with hydraulic oil until the oil comes up just past the end of the dipstick. Hydraulic tank has a 7,2 liter (1.9 US gallon) capacity.

Figure 2-6: Hydraulic Oil Tank and Filter

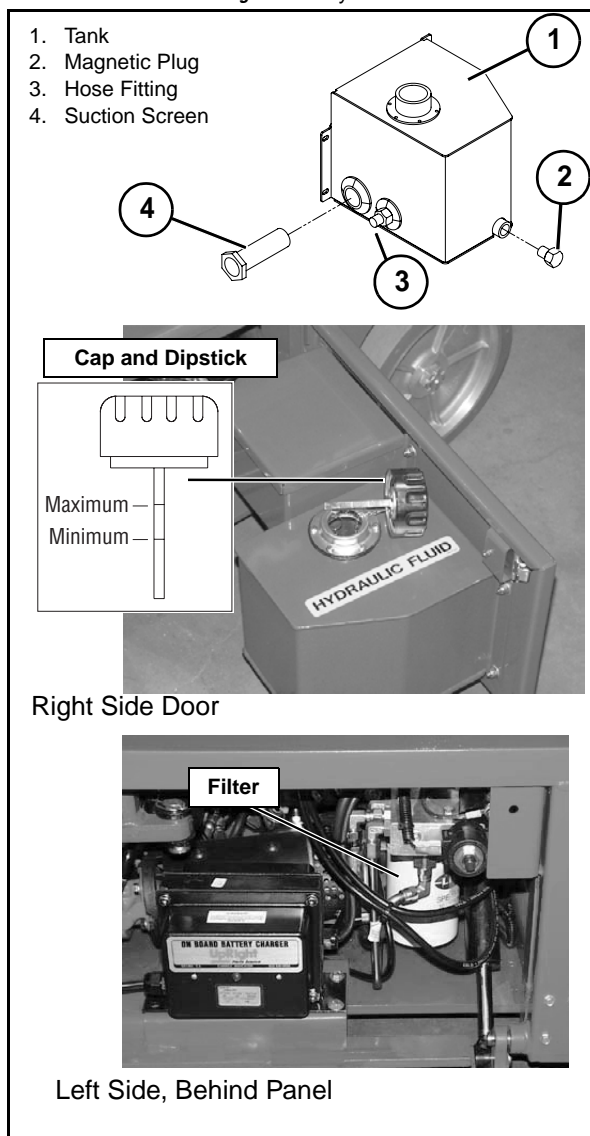

CAUTION

The hydraulic oil may be of sufficient temperature to cause burns. Wear safety gloves and safety glasses when handling hot oil.

HYDRAULIC PUMP

The Hydraulic Pump is located in the Power Module, and is mounted on the rear of the motor.

REMOVAL

NOTE: If the hydraulic tank has not been drained, suitable means for plugging the hoses should be provided to prevent excessive fluid loss.

1. Mark, disconnect and plug the hose assemblies.
2. Loosen the capscrews and remove the pump assembly from the motor.

INSTALLATION

1. Lubricate the pump shaft with general purpose grease and attach the pump to the motor with the capscrews.
2. Using a crisscross pattern, torque each capscrew a little at a time until all capscrews are torqued to 27N-m (**20 ft-lbs**).
3. Unplug and reconnect the hydraulic hoses.
4. Check the oil level in the hydraulic tank before operating the work platform.

Figure 2-7: Hydraulic Pump

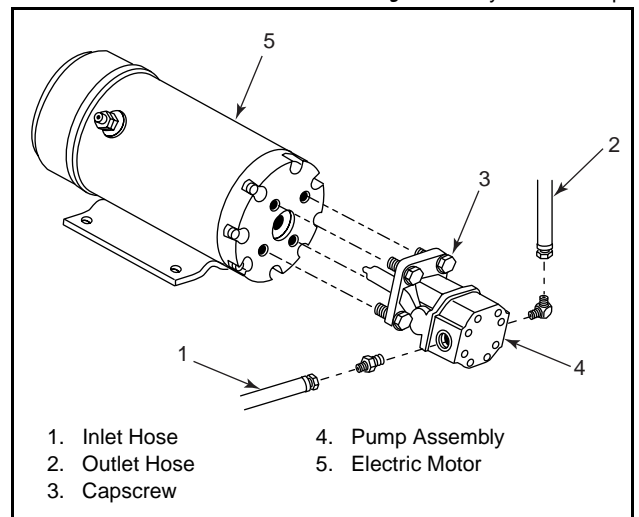

CYLINDER VALVE ASSEMBLY

Figure 2-8: Cylinder Valve

EMERGENCY DOWN VALVE

The Emergency Down Valve located at the front of the machine. The valve is a 24 Volt DC solenoid mounted on the base of the cylinder.

FLOW CONTROL VALVE ASSEMBLY

The Cylinder Valve Block is located behind the panel on the left side of the machine, toward the rear.

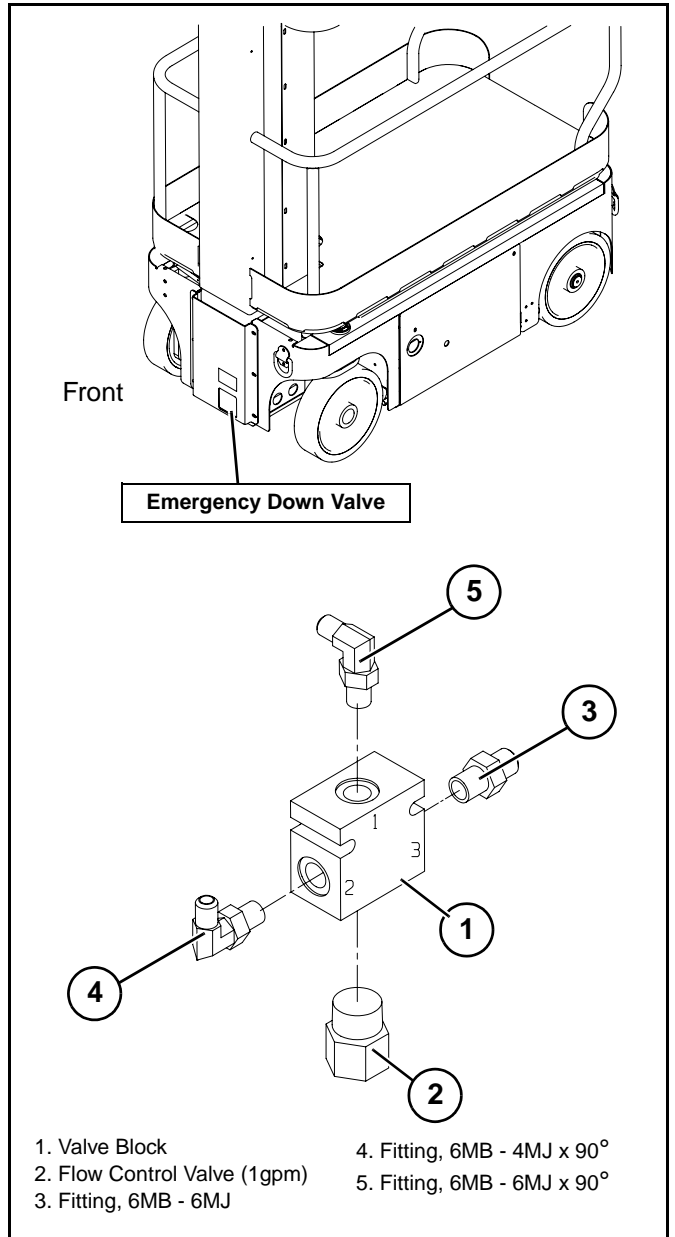

MAIN HYDRAULIC MANIFOLD

Though it is not necessary to remove the manifold to perform all maintenance procedures, a determination should be made prior to beginning as to whether or not the manifold should be removed before maintenance procedures begin.

Figure 2-9: Hydraulic Manifold | Serial # M30176 — M30338

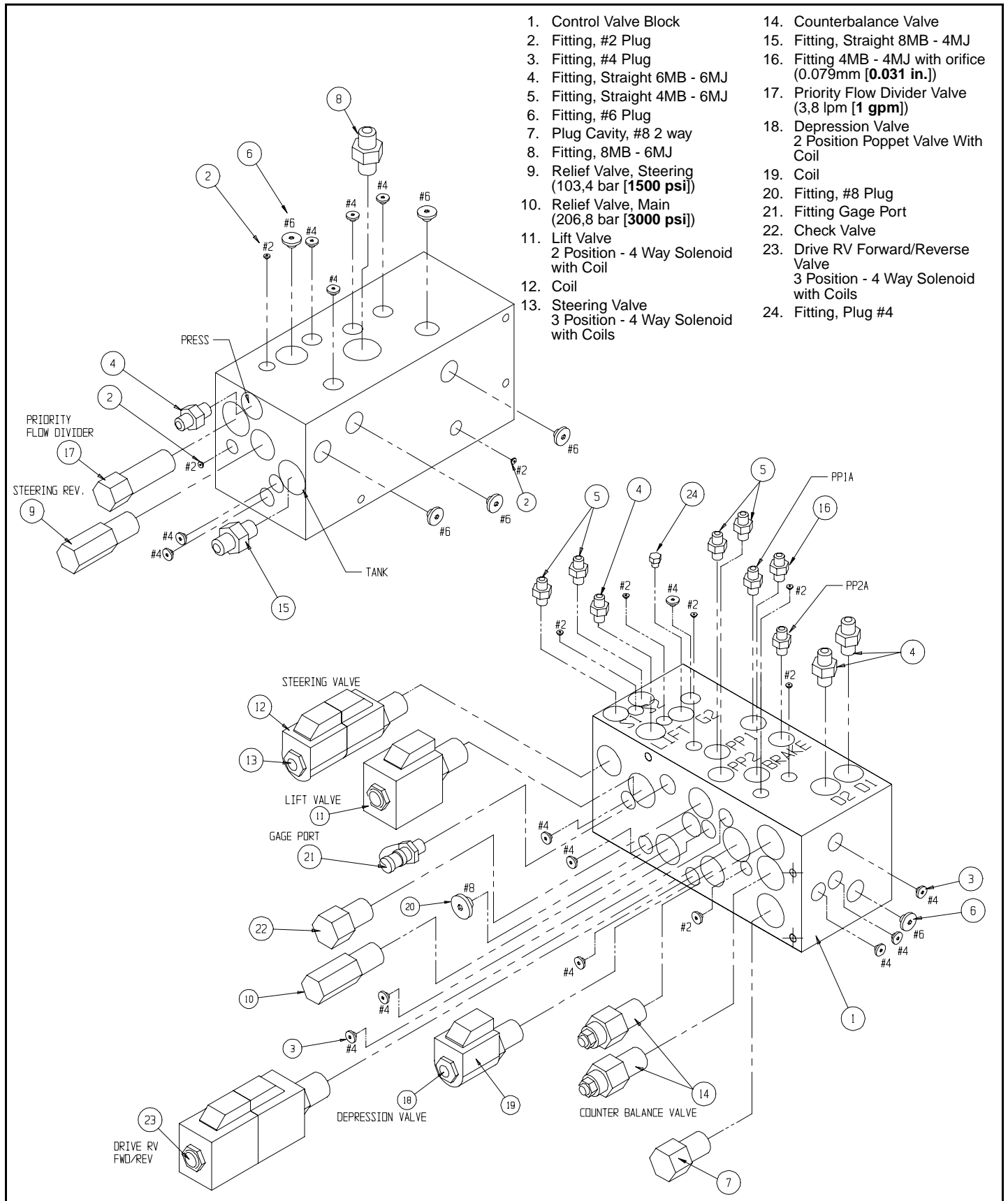
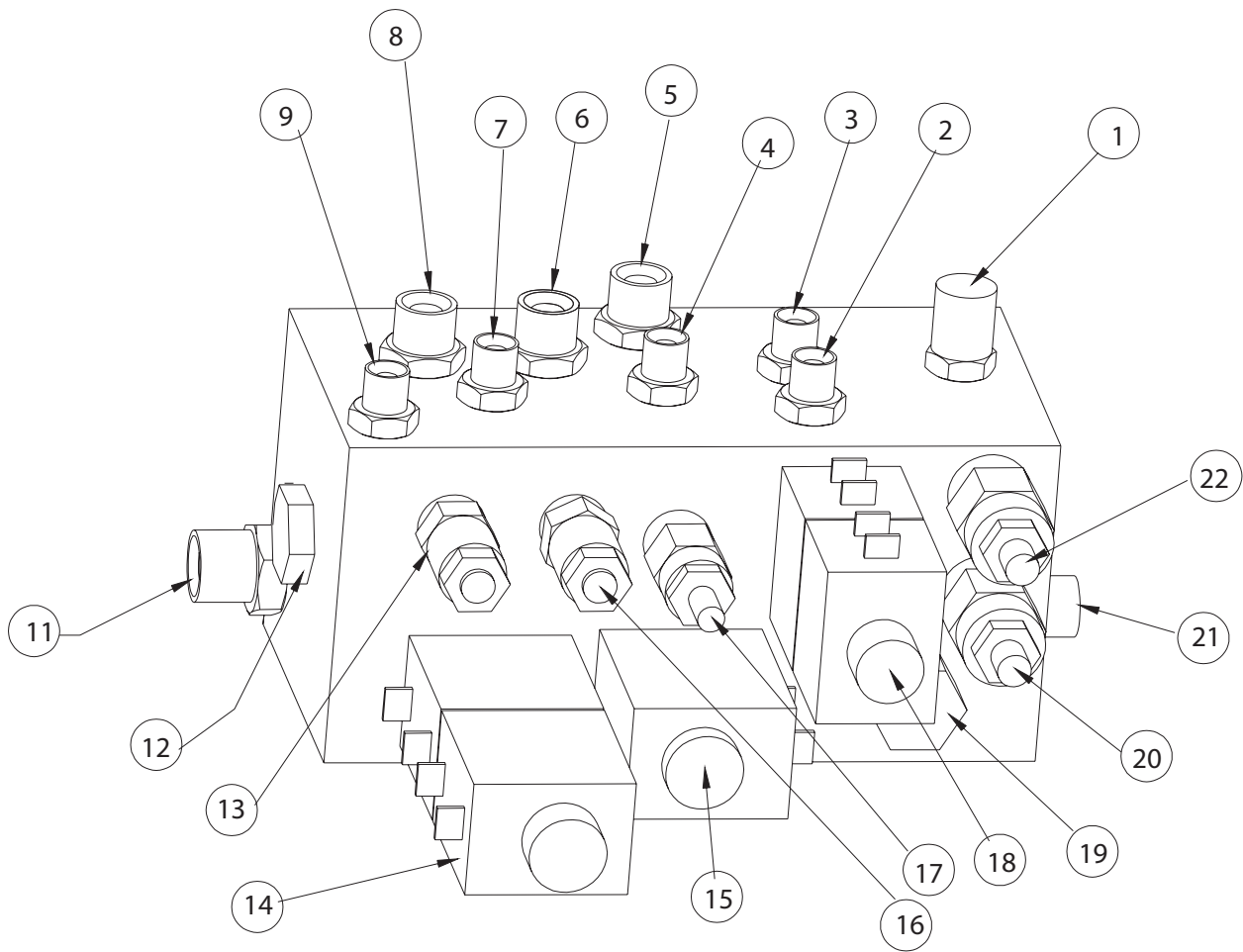

Figure 2-10: Hydraulic Manifold | Serial # M30339 — M30642



- | | |
|---|-------------------------------------|
| 1. TEST PORT (1/4") | 12. CHECK VALVE (POTHOLE) |
| 2. FITTING (1/4" - 1/4" MALE/MALE) | 13. CROSS LINE RELIEF VALVE (DRIVE) |
| 3. FITTING (1/4" - 1/4" MALE/MALE) | 14. SOLENOID VALVE (DRIVE) |
| 4. FITTING (1/4" - 1/4" MALE/MALE) | 15. SOLENOID VALVE (DRIVE/LIFT) |
| 5. FITTING (3/8" - 3/8" MALE/MALE) | 16. CROSS LINE RELIEF VALVE (DRIVE) |
| 6. FITTING (3/8" - 3/8" MALE/MALE) | 17. PRESSURE RELIEF (MAIN LIFT) |
| 7. FITTING (1/4" - 1/4" MALE/MALE WITH 1mm OROFICE) | 18. SOLENOID VALVE (STEERING) |
| 8. FITTING (3/8" - 3/8" MALE/MALE) | 19. FLOW RESTRICTOR (STEERING) |
| 9. FITTING (1/4" - 1/4" MALE/MALE) | 20. RELIEF VALVE (STEERING) |
| 10. - | 21. FITTING (3/8" - 3/8" MALE/MALE) |
| 11. FITTING (1/2" - 1/2" MALE/MALE) | 22. RELIEF VALVE (MAIN) |

SETTING HYDRAULIC MANIFOLD PRESSURES

⚠ WARNING ⚠

The hydraulic oil may be of sufficient temperature to cause burns. Wear safety gloves and safety glasses when handling hot oil.

The oil in the hydraulic system is under very high pressure which can easily cause severe cuts. **Obtain medical assistance immediately if cut by hydraulic oil.**

NOTE: Check the hydraulic pressures whenever the pump, manifold or relief valves have been serviced or replaced

MAIN RELIEF VALVE

1. Operate the hydraulic system 10 to 15 minutes to warm the oil.
2. Remove the cap or loosen the locknut on the Main Relief Valve.
3. Install a 0-207 bar (**0-3000 psi**) pressure gauge to the gauge port.
4. Turn the Chassis Keyswitch to CHASSIS and elevate the machine fully.
5. While holding the Chassis Lift Switch to the UP position, adjust the Main Relief Valve until the pressure gauge reads 165 bar (**2400 psi**).
6. Release the Chassis Lift Switch.
7. Replace the cap, or tighten the locknut on the Lift Relief Valve, and torque to 8N-m (**6 ft-lbs**).
8. Lower the platform.

Figure 2-11: Hydraulic Manifold relief | Serial # M30176 — M30338

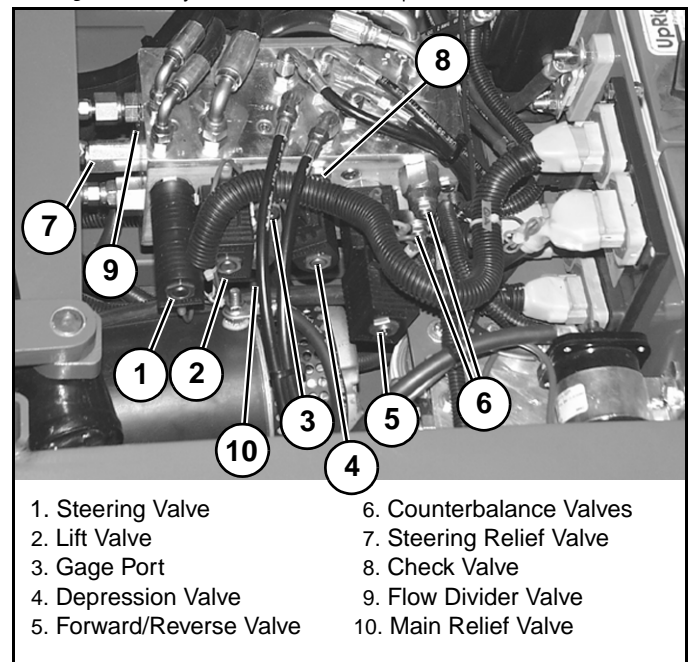
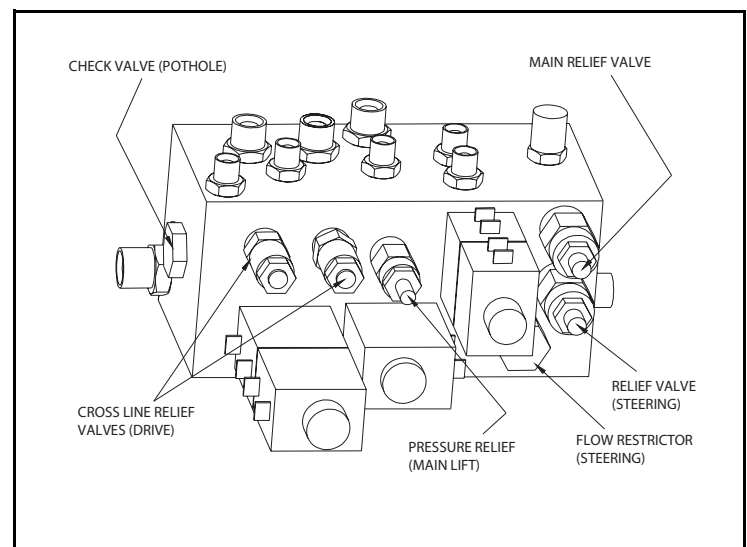

Figure 2-12: Hydraulic Manifold Relief | Serial # M30339 — M30642



COUNTERBALANCE VALVES

1. Operate the work platform for 10-15 minutes to bring the hydraulic oil up to normal operating temperature.
2. Remove the gauge port cap and install the pressure gauge assembly.
3. Lift work platform and block front wheels off ground.
4. Loosen the locknuts on Counterbalance Valves.
5. With the Chassis Key Switch on **DECK** and the Drive/Lift Switch in **DRIVE**, depress the Interlock Lever and slowly pull the Control Lever to **REVERSE** to drive the wheels.
6. Adjust the Forward Counterbalance Valve by turning the adjustment screw until the pressure gauge indicates 83 bar (**1200 psi**).
7. Slowly push the Control Lever to **FORWARD** to drive the wheels.
8. Adjust the Reverse Counterbalance Valve by turning the adjustment screw until the pressure gauge indicates 83 bar (**1200 psi**).
9. Check the settings by slowly moving the Control Lever **FORWARD**, then **REVERSE**, checking the gauge to ensure pressures are properly set. Re-adjust as needed.
10. Tighten locknuts on valves to 8N-m (**6 ft-lbs**). Remove blocks and lower work platform to ground.
11. Reconnect the red Control Cable wire to terminal #9.
12. Remove the gauge from the gauge port and re-install cap.
13. Check for proper operation of the drive system and brake.

STEERING RELIEF VALVES

1. Operate the work platform for 10-15 minutes to bring the hydraulic oil up to normal operating temperature.
2. Install gauge in the gauge port.
3. Loosen locknut or remove cover on the Steering Relief Valve and turn adjusting screw counter-clockwise two full turns.
4. While one person holds the Steering Switch to steer right or left, slowly turn the Steering Relief Valve adjusting screw clockwise to increase the pressure until the gauge reads 69 bar (**1000 psi**).
5. Tighten locknut or replace Steering Relief Valve cover and torque to 8N-m (**6 ft-lbs**).
6. Remove gauge and replace cap.

2-8 CYLINDERS

DEPRESSION CYLINDER

Figure 2-13: Depression Cylinder Remove & Replace

REMOVAL

1. Mark and disconnect the hose assemblies from the cylinder fittings and immediately cap the openings to prevent foreign material from entering.
2. Place a support under the depression guard.
3. Remove the cotter pins from the pivot pins.
4. Remove the pivot pins while supporting the cylinder.
5. Remove the cylinder.

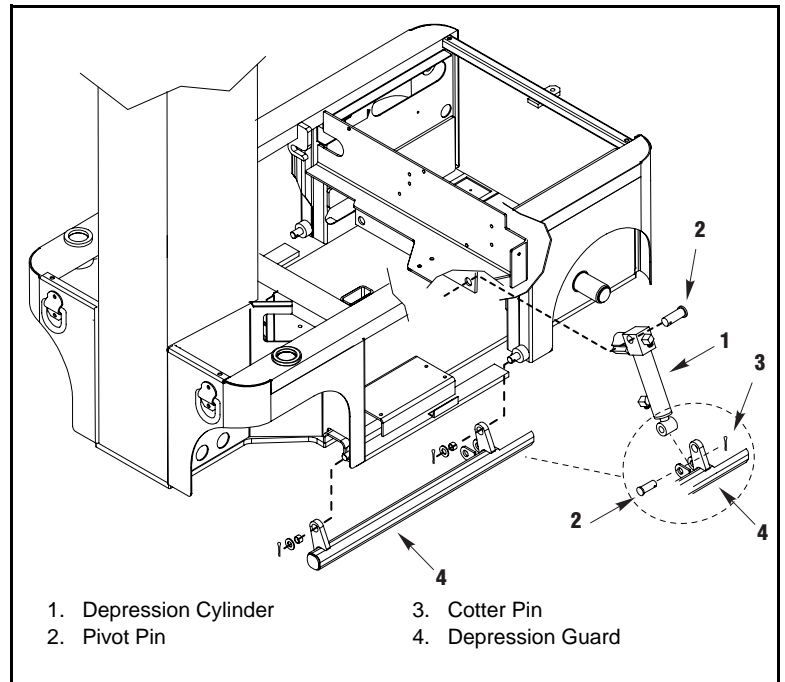

REPAIR

Refer to Cylinder Repair in Section 1 - General Information.

INSTALLATION

Installation is reverse of removal.

BRAKE CYLINDER

The brake cylinder is located inside the right rear chassis wall above the wheel.

Figure 2-14: Brake Cylinder, Remove & Replace

REMOVAL

1. Block the wheels to prevent the work platform from rolling when the brake is removed.
2. Use a 1000Kg (**one ton**) capacity jack to raise the rear of the machine. Position blocks under the machine to prevent the work platform from falling if the jack fails.
3. Block the front wheels to prevent the machine from rolling.
4. Remove the spring compression nut and flat washer from the tension bar.
5. Remove the retaining ring and right rear wheel.
6. Remove the cotter pin and pivot pin from the rear cylinder mount.
7. Remove the cotter pin from the tension bar pivot allowing the cylinder to be lowered.
8. Disconnect the hose assemblies and cap the openings to prevent foreign material from entering.
9. Remove the cylinder from the chassis.

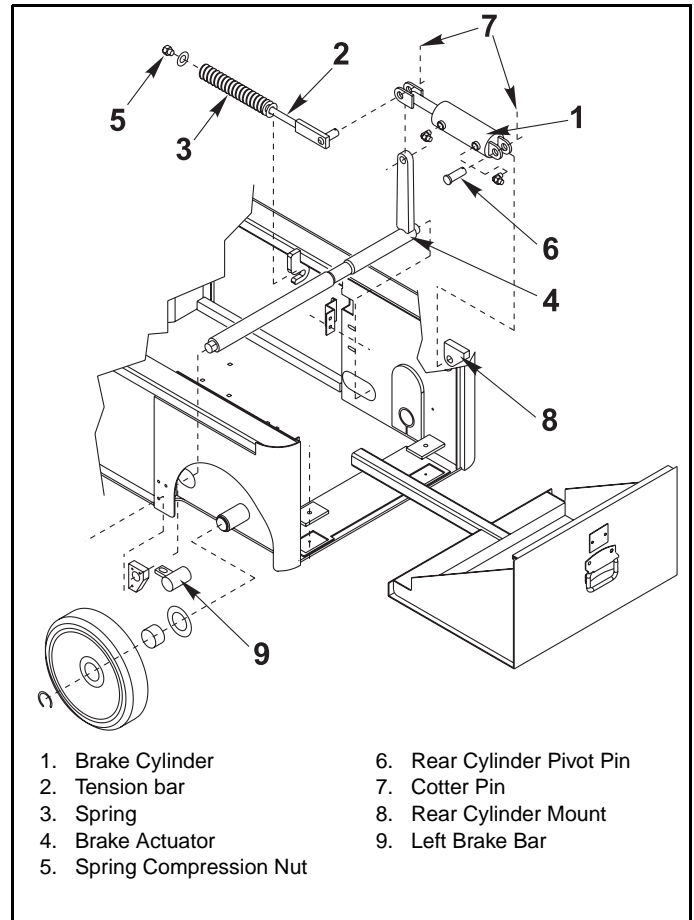

REPAIR

Refer to Cylinder Repair in Section 1 - General Information.

INSTALLATION

1. Connect the hose assemblies.
2. Install the tension bar pivot through the cylinder clevis and brake actuator and secure with a new cotter pin.
3. Install the pivot pin through the cylinder mounting tabs and rear cylinder mount and secure with a new cotter pin.
4. Install the wheel and retaining ring.
5. Install the flat washer and spring compression nut on the tension bar. Tighten the nut until at least flush with the tension bar shaft or until the brake bar has full engagement with the tire.
6. Lower the machine and operate the drive circuit and check that the brake bars retract and clear the tires when driving and fully engage the tires when stopped. Check for leaks

STEERING CYLINDER

REMOVAL

1. Mark and disconnect the hose assemblies from the cylinder fittings and immediately cap the openings to prevent foreign material from entering.
2. Remove the cotter pins from the pivot pins.
3. Remove the pivot pins while supporting the cylinder. Remove the cylinder.

REPAIR

Refer to Cylinder Repair in Section 1 - General Information.

INSTALLATION

1. Position the cylinder assembly in the chassis and insert pivot pins and secure with new cotter pins.
2. Connect the hose assemblies to the fittings.
3. Operate the steering circuit several times throughout its entire range of travel to expel trapped air and check for leaks.

Figure 2-15: Steering Cylinder Remove & Replace

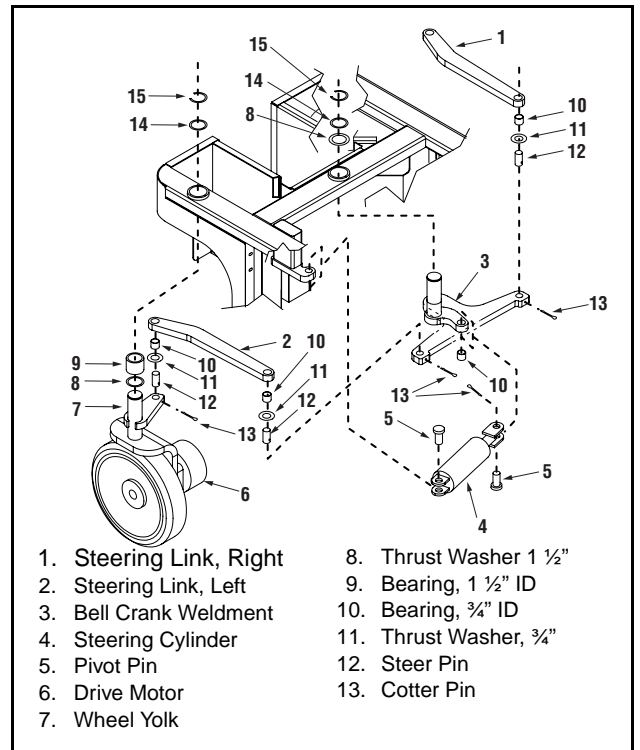
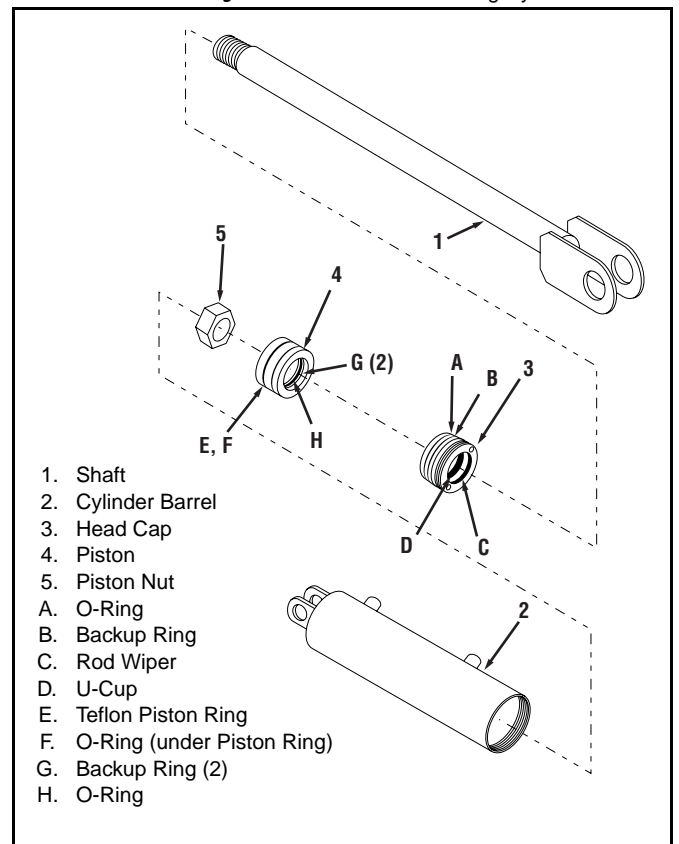

Figure 2-16: Brake and Steering Cylinder Seal Kit



LIFT CYLINDER

REMOVAL

Refer to Figure 2-19: "Elevating Assembly," on page 2-22 for details.

1. Fully lower platform.
2. Provide a suitable container to catch the hydraulic fluid, then disconnect the hydraulic hose. Immediately plug hoses to prevent foreign material from entering.
3. Remove the adapter from the base of the cylinder, inside the chassis.
4. Remove the Emergency Lowering Valve Knob from the valve at the base of the cylinder, then remove the Emergency Lowering Valve out the access hole in the bottom of the chassis.
5. Remove the snap ring at the bottom of the cylinder under the chassis.
6. Detach the 6.35mm (0.25 in.) vent line tubing from the top of the hydraulic tank, and cut any plastic ties that secure the tubing. Plug the end of the tubing to prevent contamination.
7. Remove the platform mast cover.
8. Remove the capscrew and locknut securing the cylinder rod to the upper cylinder mount.
9. Attach a suitable hoisting device and sling to the cylinder. Carefully lift the cylinder approximately 0.5 m (18 in.) until you can see the vent line tubing attached near the top of the cylinder barrel. Detach the tubing by depressing the green ring on the fitting at the same time you pull firmly on the tube. Plug the end of the tube and the fitting to prevent contamination.
10. Raise the cylinder the rest of the way through the top of the mast.

Figure 2-17: Lift Cylinder Seal Kit

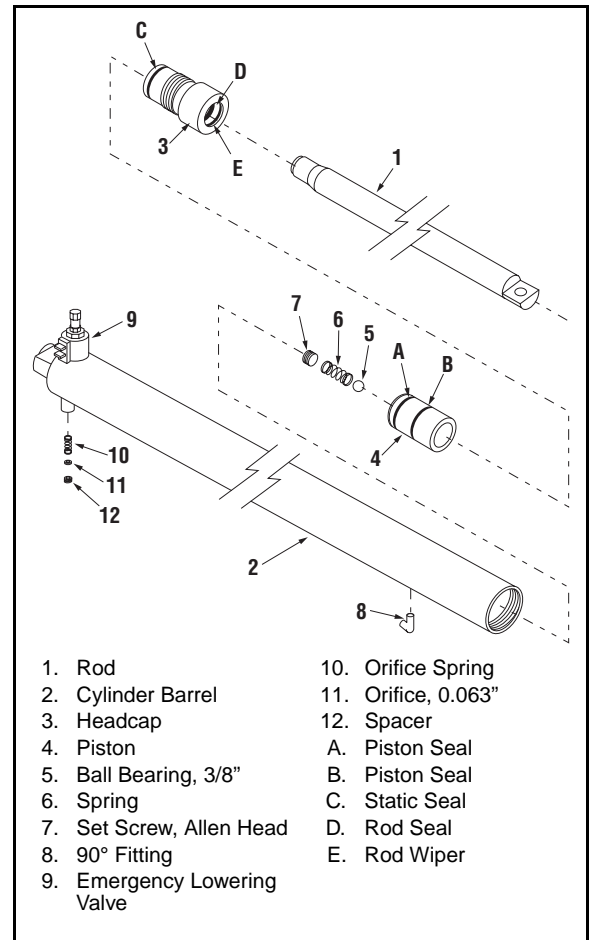

REPAIR

Refer to Cylinder Repair in Section 1 - General Information.

INSTALLATION

1. Attach a suitable hoisting device and sling to the cylinder. Carefully lower the cylinder through the top of the mast until you can reattach the vent line tubing. Simply push the tubing into the fitting until it goes no further. Pull firmly to ensure that it is installed correctly.
2. Lower the cylinder the rest of the way, and secure the cylinder to the chassis with the snap ring.
3. Install capscrew, washers and locknut securing cylinder rod to the upper cylinder mount.
4. Install platform mast cover.
5. Install the Emergency Lowering Valve, Knob and adapter to the base of the lift cylinder.
6. Remove the plug from the hydraulic hose and attach it to the adapter.
7. Attach the vent line to the hydraulic tank.
8. Test with weight at rated Platform load to check system operation. Check for leaks

2-9 DRIVE MOTORS

REMOVAL

1. Use a 1000Kg (**one ton**) capacity jack to raise the front of the machine. Position blocks under the machine to prevent the work platform from falling if the jack fails.
2. Block the rear wheels to prevent the machine from rolling.
3. Remove the cotter pin, nut, and washer.
4. Remove the wheel.

NOTE: Before disconnecting hoses, thoroughly clean off all outside dirt around fittings. (After disconnecting hoses and before removing from vehicle, IMMEDIATELY plug port holes.)

5. Tag, disconnect and plug the hose assemblies to prevent foreign material from entering.
6. Support the drive motor/wheel yoke assembly and remove the retaining ring at the top of the wheel yoke pivot. Remove the drive motor/wheel assembly from the machine.
7. Remove the locknuts, flat washers, capscrews and drive motor from the wheel yoke.

INSTALLATION

1. Position the drive motor in the wheel yoke and secure with capscrews, flat washers and locknuts.
2. Install the drive motor/wheel yoke assembly into the pivot bearing along with the lower thrust washer, thrust bushing, and retaining ring.
3. Align the steer pin with the hole in the steering link.
4. Remove the plugs from the hose assemblies and connect to the drive motor.
5. Install the shaft key, wheel, washer and slotted nut. Torque the locknut to 102 N-m (**75 ft-lbs**). Install a new cotter pin. **DO NOT** back-off the nut to install cotter pin.
6. Remove blocks, lower the jack and remove. Operate the drive system and check for leaks.

Figure 2-18: Drive Motor Assembly

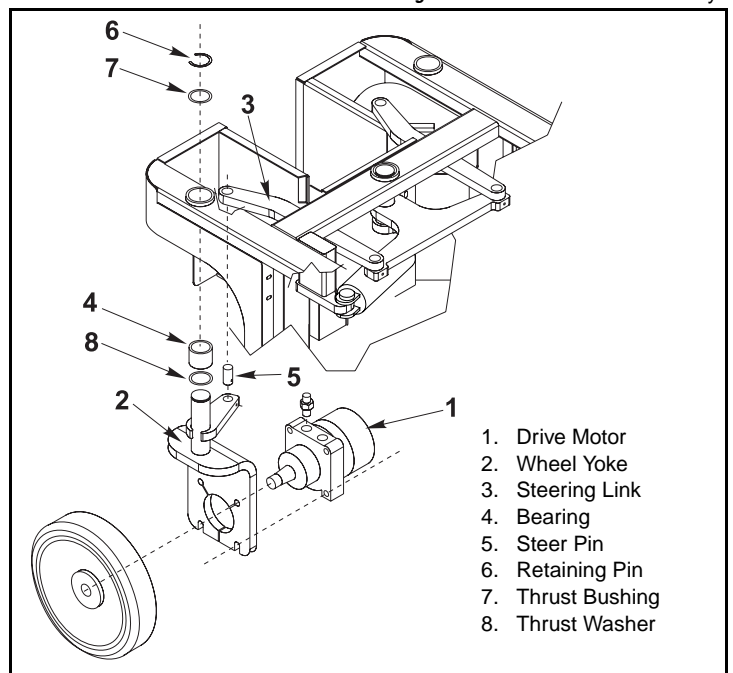

2-10 ELEVATING ASSEMBLY

Maintenance of the elevating assembly consists of four separate tasks and maintenance intervals:

- Chain Lubrication 6 months
- Elevating Assembly Wear Inspection 6 months
- Chain Tension Inspection 1 year
- Chain Elongation Inspection 5 years

All of the tasks except the Elongation Inspection can be done without removing the chains from the assembly.

Figure 2-19: Elevating Assembly

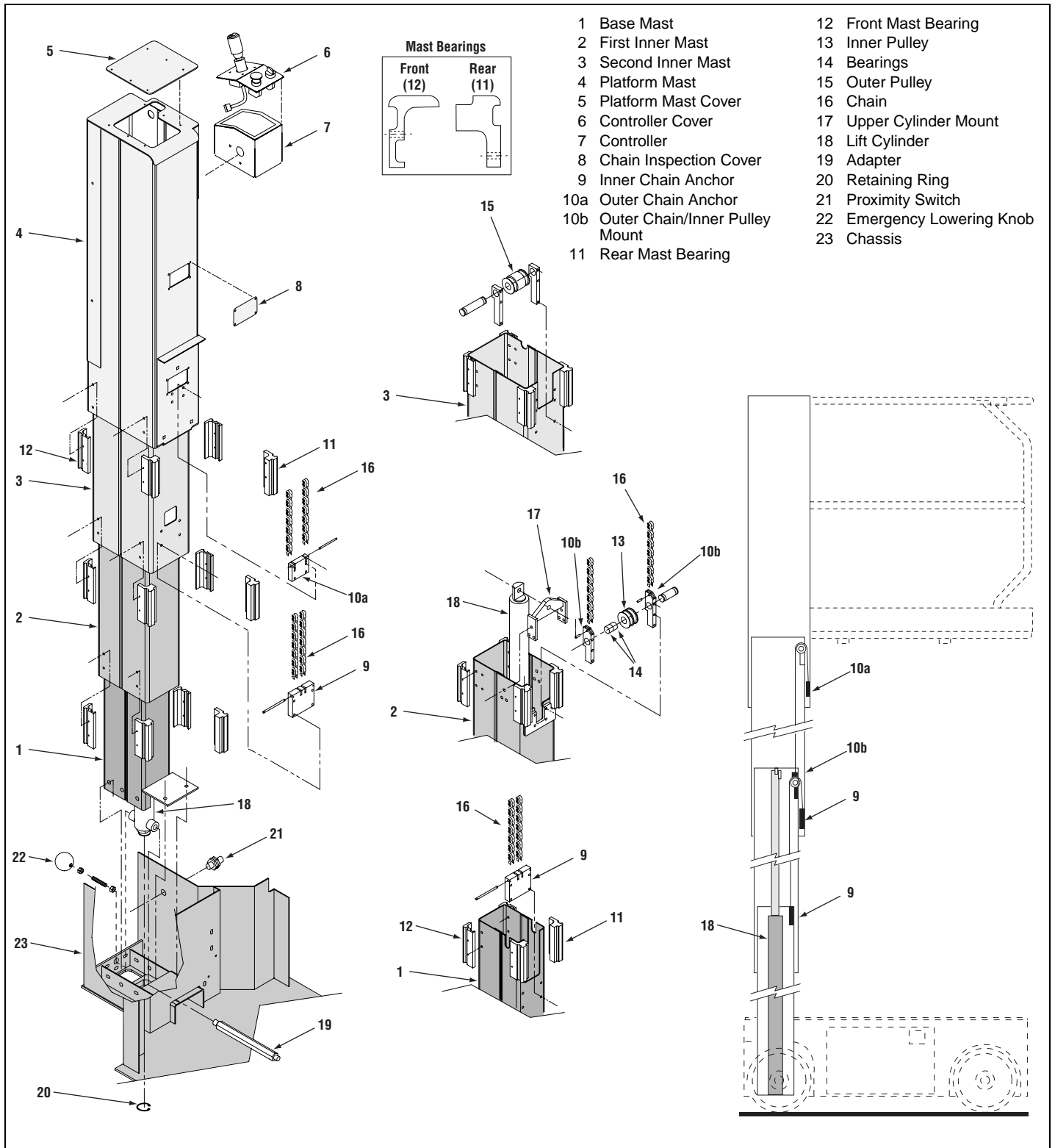

LIFT CHAIN LUBRICATION

Refer to Figure 2-19: “Elevating Assembly,” on page 2-22.

With platform in the stowed position;

- remove the *platform mast cover* (5).
- apply enough aerosol chain lubricant to the exposed portion of all four chains to allow the lubricant to run down the chains.
- replace the cover.
- remove the chain inspection cover (8).
- raise platform approximately 10cm (4 in.), until the inner set of chains are visible through the chain inspection hole.
- apply enough aerosol chain lubricant to the exposed chain to allow the lubricant to run down the chain.
- replace chain inspection cover.

ELEVATING ASSEMBLY WEAR INSPECTION

Refer to Figure 2-19: “Elevating Assembly,” on page 2-22.

At the same time as the chain lubrication task, inspect all elevating assembly components for wear.

With the platform in the stowed position;

- inspect the system through the *platform mast cover* (5) to look for worn *pulleys* (13 & 15) or damaged components.
- Inspect the *chain anchors* (10a & 10b) and visible portions of lift chain as you lubricate it.
- Look for cracks in the chain links, kinks in any portion of chain, and excessive corrosion.

From the lower controls, raise the platform and block the elevating assembly (see Figure 2-1: “Supporting Elevating Assembly,” on page 2-3).

- Inspect the *inner chain anchors* (9) and the ends of the chains for damage or worn parts. If damage is present, replace the components.

IMPORTANT: There are two pairs of two chains each, for a total of four chains. If only one chain of either pair is damaged, both chains in the pair must be replaced.

CHAIN TENSION INSPECTION

Refer to Figure 2-19: "Elevating Assembly," on page 2-22.

The lifting chains are self-adjusting and should always be close to the same tension. This tension should be checked annually to ensure that there are no problems with this system. To do this task a spring scale will be needed with 20kg (**44 lb.**) capacity.

1. Place 227kg (**500 lbs.**) in the platform including the weight of the person testing the chain tension.
2. Remove the *chain inspection cover* (8) and raise the platform approximately 10cm (**4 in.**) until the outer inspection hole lines up with the inner inspection hole.
3. Attach the spring scale to one of the outer chains and pull until the chain makes contact with the inner surface of the mast section. Note the scale reading.
4. Repeat step 3 on the other outer chain.
5. Compare the scale readings. The readings for each chain in the outer set should be within 20% of each other.
6. Repeat steps 3 - 5 for the inner set of chains. The readings for each chain in the inner set should be within 20% of each other.

IMPORTANT: If the readings are not within 20%, then a problem exists that is causing unequal chain tension. Investigate the problem and repair or replace the worn components.

CHAIN ELONGATION INSPECTION

At five-year intervals, the chains should be removed from the mast and the entire length of the chain inspected for excessive wear and elongation. Follow the procedure below to disassemble the elevating assembly. With the lift chains removed, hang them vertically from something capable of holding 100kg (**220 lbs.**). Inspect the chains thoroughly, looking for cracks in the chain links, kinks in any portion of chain, and excessive corrosion. Complete the following elongation test:

1. Attach approximately 25kg (**55 lbs.**) to the lower end of each chain.
2. Measure the distance between 50 pins. This distance should be 63.5cm - 65.5cm (**25 in. - 25¾ in.**).
3. Remove the weight and measure the same on the other three chains.

If the chains have elongated beyond the indicated range, replace the lift chain sets. Before reinstalling the lift chains, take this opportunity to thoroughly clean and lubricate the entire chain. Reassemble the elevating assembly as described below.

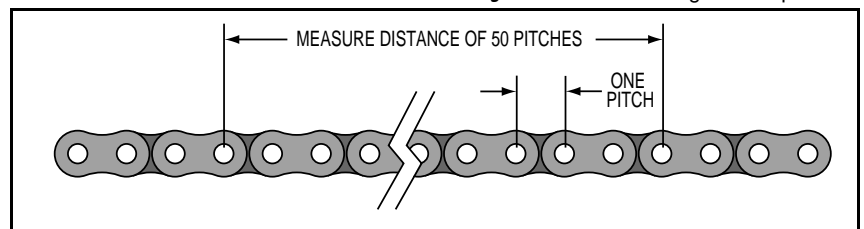

REMOVAL OF ELEVATING ASSEMBLY

Refer to Figure 2-19: "Elevating Assembly," on page 2-22.

1. Disconnect the batteries using the battery disconnect in front of the batteries in the battery tray.
2. Remove the *platform mast cover* (5), and the *controller cover plate* (6).
3. Detach the control cable inside the *controller* (7), remove the cable clamp in the top of the *platform mast* (4), and feed the cable into the *second inner mast* section (3).
4. Using a suitable hoisting device, carefully raise the *platform mast* (4) until you can access the *outer chain anchor* (10a).
5. Disconnect the *outer chain anchor* from the *platform mast*, but leave the anchor attached to the chains.
6. Remove the lower mast bearings from the *platform mast*. The front two mast bearings may be removed by drilling out the lower pop rivets that retain the bearings.
7. Raise the *platform mast* straight up and off of the remaining mast sections.
8. Lay the chain that was detached from the *platform mast* over the top of the *upper cylinder mount* (17), and place it down inside the *second inner mast* section.
9. Repeat steps 4 - 7 on the *second inner mast* section (3). The lower mast bearings are removed by unscrewing the two screws on each bearing.
10. The upper chain set may now be removed by detaching the *upper chain/inner pulley mounts* from the *first inner mast* section (2). Carefully set the chain set aside on a clean surface.
11. Remove the single bolt that attaches the *cylinder* to the *upper cylinder mount* (17).
12. Using a suitable hoisting device, carefully raise the *first inner mast* section (2) up several inches.
13. Lay the remaining chain set over the top of the *cylinder*, and place it down inside the inner mast section.
14. Remove the lower mast bearings from the *first inner mast* section.
15. Raise the *first inner mast* section straight up and off of the remaining *base mast* section.
16. The inner chain set may now be removed.
17. If it is necessary to remove the *base mast* section, remove the nine bolts that secure it to the *chassis*. It may be required to remove the *lift cylinder* to provide easier access to the bolts (see "Lift Cylinder" on page 2-20).

INSTALLATION OF ELEVATING ASSEMBLY

Refer to Figure 2-19: "Elevating Assembly," on page 2-22.

Installation of the elevating assembly is the reverse of removal.

- Torque the nine bolts that retain the *base mast* section to 68N-m (**50 ft-lbs**).
- For all of the cap screws that attach the chain anchors to the mast sections, apply Loctite #242 to the screw threads and torque to 12N-m (**107 in-lbs**).
- For all of the screws that attach the mast bearings, apply Loctite Retainer #405 to the screw threads. *Do not torque, simply tighten securely.*
- Check elevating assembly for proper operation.

2-11 TILT SENSOR

⚠ WARNING ⚠

Never perform service on the work platform in the elevating assembly area while platform is elevated without first blocking the elevating assembly.

DO NOT stand in elevating assembly area while deploying or storing brace.

The Tilt Sensor has three wires; red-power (24v in), black-ground, white-output (24v out). To verify the sensor is working properly, there is one red LED under the sensor. If the LED is on, the sensor is off level.

ADJUSTMENT

1. Place machine on firm level surface $\pm 1/4^\circ$.
2. Use the Inclinator (p/n 010119-000) to ensure front and rear of Chassis is level $\pm 1/4^\circ$.
3. Adjust the three leveling screws until the bubble is centered in the circle on the attached bubble level.

TEST

1. Raise the platform approximately 2m (7 ft.).
2. Support the elevating assembly (see "Supporting Elevating Assembly" on page 2-3).
3. Push the level sensor to the side.

The red LED should turn on, and the tilt alarm should sound.

Figure 2-21: Tilt Sensor

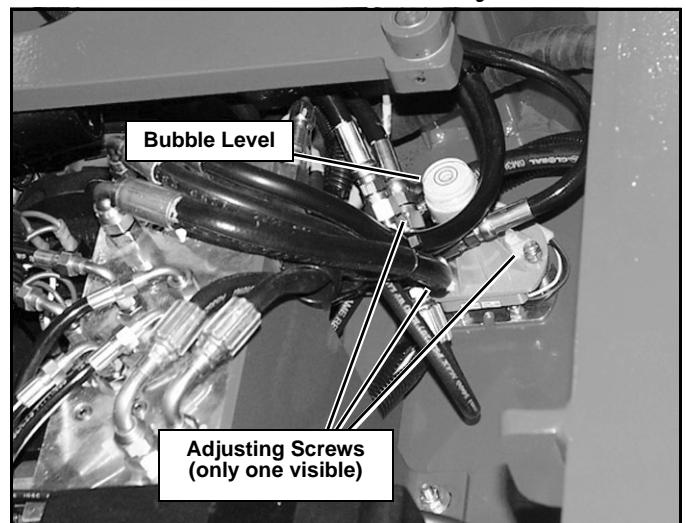

2-12 CONTROLS

PLATFORM CONTROLS

The Proportional Controller can be disassembled to replace defective switches. See the Parts Manual for replacement part numbers.

Figure 2-22: Upper Controls | Serial # M30176 — M30338

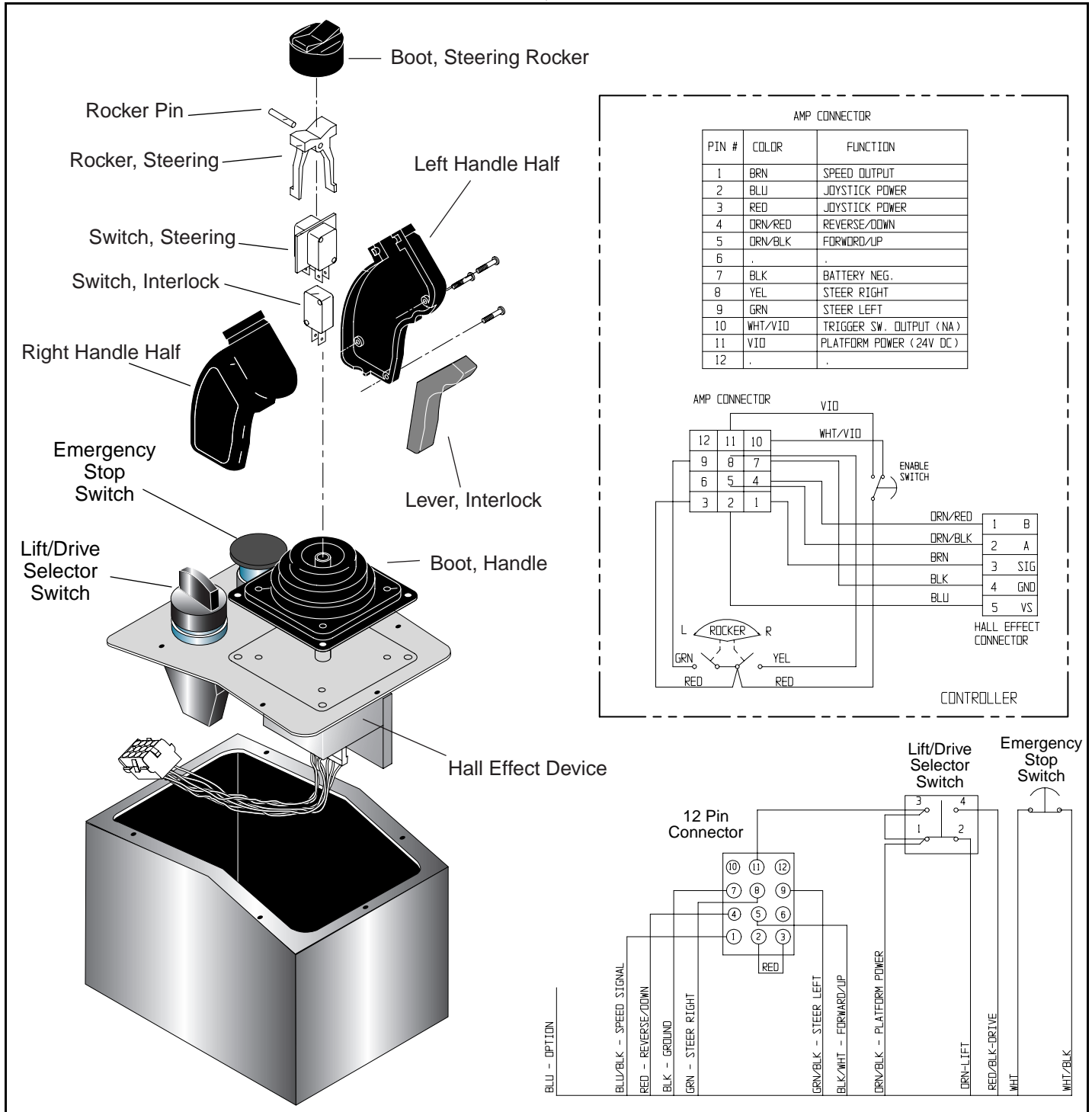
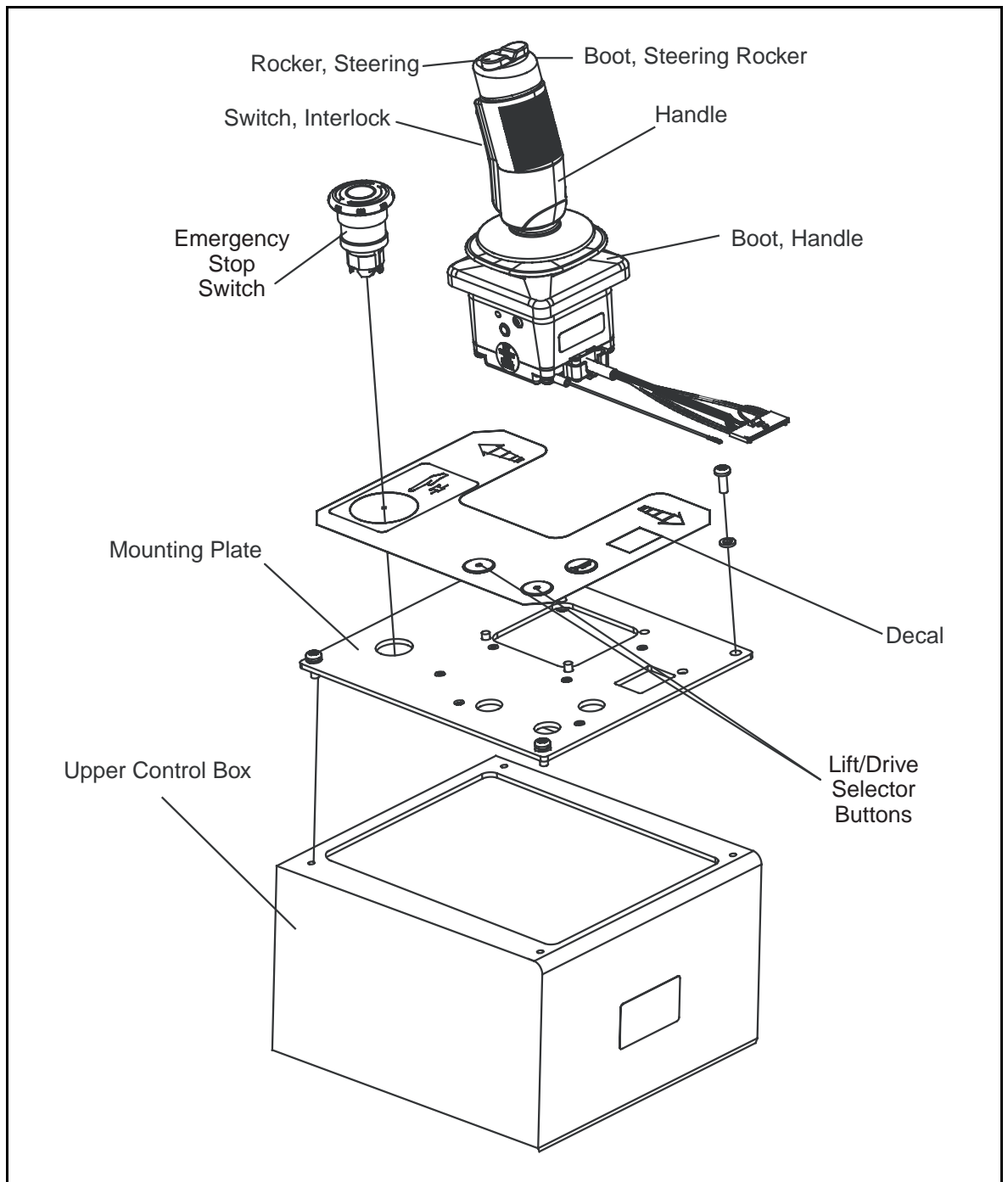

Figure 2-23: Upper Controls | Serial # M30339 — M30642



CHASSIS CONTROLS

The chassis control assembly is mounted on the inside of the chassis door, to the left of the Hydraulic tank. It is secured to the door with Four carriage bolts (1/4-20UNC x 3/4).

Figure 2-24: Chassis Controls | Serial # M30176 — M30338

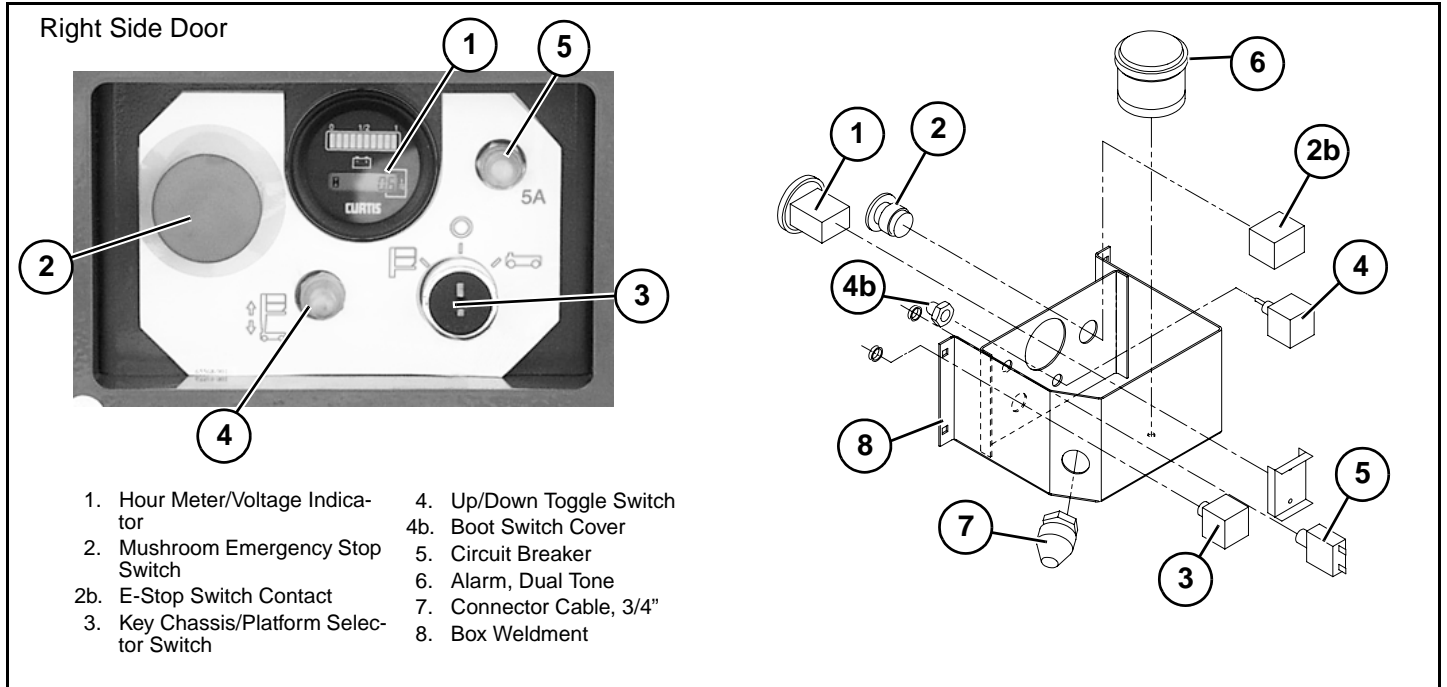
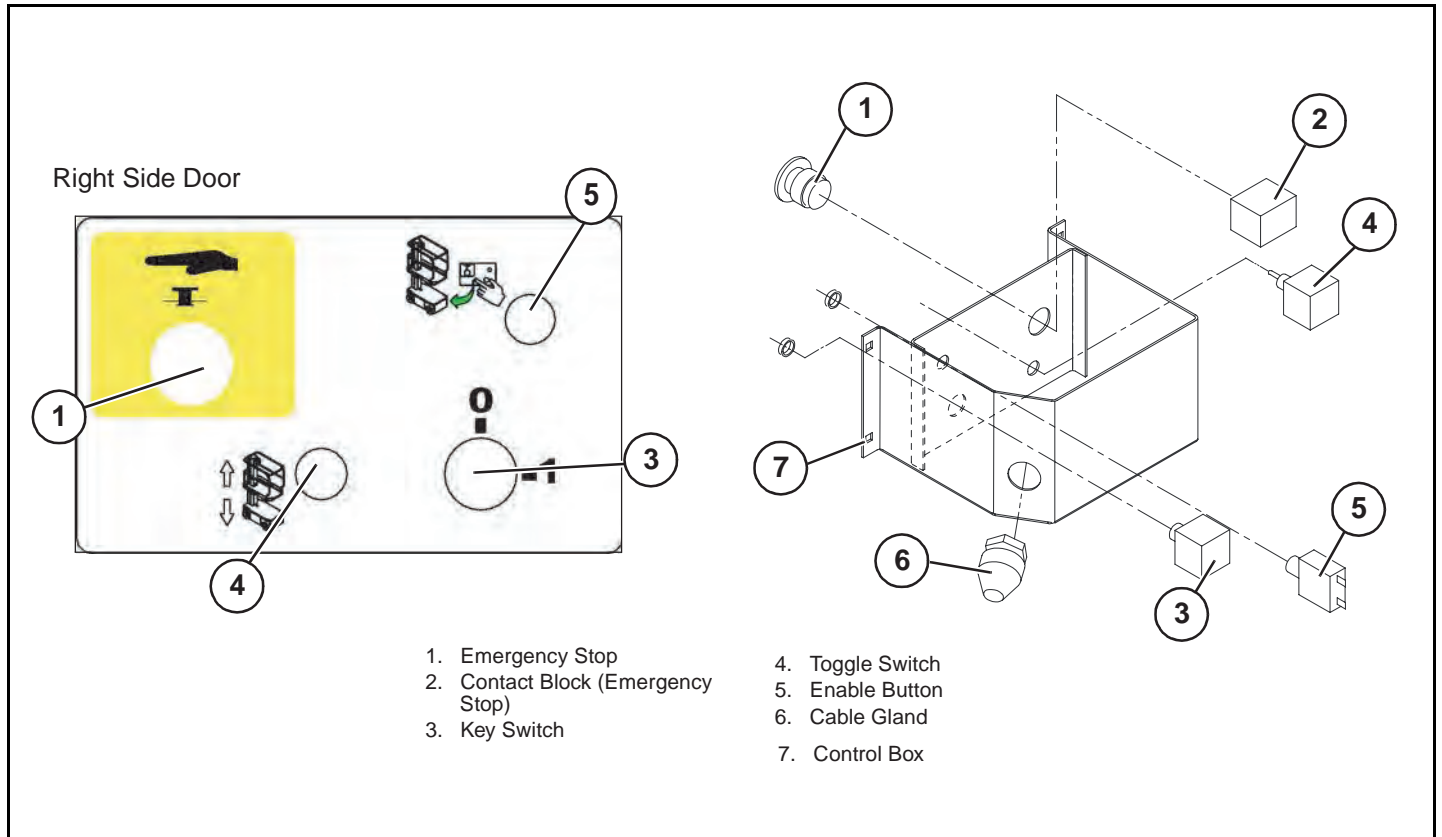

Figure 2-25: Chassis Controls | Serial # M30339 — M30642



2-13 MOTOR CONTROLLER AND I/O BOARD DIP SWITCH SETTINGS | SERIAL # M30176 — M30338

NOTE: - Before dip switch settings will take effect, power must be disconnected or Emergency Stop switches must be depressed.
 - Refer to Section 4 for diagnostics.

CONTROLLER

	1	2	3	4	5	6	7	8
TM12	off	off	off	on	off	off	off	on
MX15/19	off	on	off	on	off	on	off	on
X/20N	on	off	off	on	off	off	off	on
X20W	on	on	off	on	off	off	off	on
X26/31	on	on	off	on	off	off	off	on
SL20	on	off	off	on	off	off	off	on

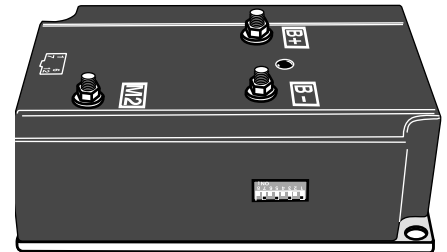
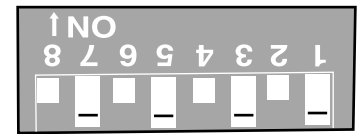

Figure 2-26: Controller

The above table shows the default dip switch settings on the controller box when the machine leaves the factory. The following adjustments may be made to these settings:

Switches 3 & 4 determine the elevated “creep” speed. If the machine does not operate at the specified speed at the default settings, use the following table to adjust the dip switch settings

Switches 5 & 6 determine the deceleration time. Switch 5 is for the deceleration rate while the platform is lowered. Switch 6 is for the elevated rate.



	3	4
1 (slowest)	off	off
2	on	off
3 (default)	off	on
4 (fastest)	on	on

Decel	5	6
.24 sec.	off	off
1.27 sec.	on	on

I/O (CIRCUIT) BOARD

	1	2	3	4
TM12	off	off	off	off
MX15/19	off	off	off	off
X/20N	off	off	off	off
X20W	off	off	off	off
X26/31	off	off	off	off
SL20	off	off	off	off

Figure 2-27: I/O Board

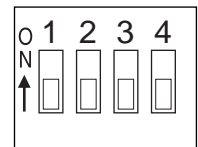

The above table shows the default dip switch settings on the I/O board when the machine leaves the factory. Switches three and four work together to determine the optional alarm settings.

1	2	3	4	Result
on				Two Speed Mode (not used)
off				Proportional Control
	on			not used
	off			Depression Mechanism extends when platform is raised
		off	off	Down alarm only
		on	off	Down and Reverse alarm
		off	on	Drive and Down alarm
		on	on	All Motion alarm

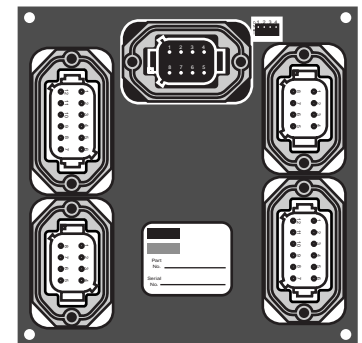

TROUBLESHOOTING

This section contains troubleshooting Truth Tables.

Careful inspection and accurate analysis of the symptoms listed in the Troubleshooting Guide will localize the trouble more quickly than any other method. This manual cannot cover all possible problems that may occur. If a specific problem is not covered in this manual, call our toll free number for service assistance.

Referring to the Operator Manual and the Schematics section will aid in understanding the operation and function of the various components and systems of the Work Platform and help in diagnosing and repair of the machine.

⚠ WARNING ⚠

When troubleshooting, ensure that the work platform is resting on a firm, level surface.

When performing any service which requires the platform to be raised, the Elevating Assembly must be blocked.

Disconnect the battery when replacing or testing the continuity of any electrical component.

TABLE OF CONTENTS

3-1 Technical Support	2-3
3-2 General Procedure	2-3
3-3 Troubleshooting Procedures	2-3
Adjustment Procedures	2-3
Checking Pump Pressures	2-3
3-4 Motor Controller Dip Switch Settings	2-4
Default Dip Switch Settings	2-4
Adjusted Dip Switch Settings	2-4
3-5 I/O Board Dip Switch Settings	2-5
Default Settings	2-5
Optional Settings	2-5
3-6 LED Fault Codes	2-6
3-7 LEDs at I/O Board	2-7
3-8 I/O Board Inputs and Outputs	2-8
3-9 Fault Codes Introduction	2-11
FAULT CODES INTRODUCTION	2-11
3-10 FAULT CODES	2-12
3-11 Electric	2-13
3-12 Hydraulic	2-14

LIST OF FIGURES

Figure 3-1: Hydraulic Test Port 2-3
Figure 3-2: Controller 2-4
Figure 3-3: I/O Board 2-5
Figure 3-4: Motor Controller 2-6
Figure 3-5: I/O Board 2-7

LIST OF TABLES

Table 3-1: LED Fault Codes 2-6
Table 3-2: Connector J1 2-8
Table 3-3: Connector J2 2-9
Table 3-4: Connector J3 2-9
Table 3-5: Connector J4 2-10
Table 3-6: Connector J5 2-10
Table 3-7: Electrical Troubleshooting Table 2-13
Table 3-8: Hydraulic Troubleshooting Table 2-14

3-1 TECHNICAL SUPPORT

Technical Support is available by telephone or FAX.

**UPRIGHT
USA** Tel: 1-559-443-6600
FAX: 1-559-268-1756

**UPRIGHT
EUROPE** Tel: +353-1-620-9300
FAX: +353-1-620-9301

3-2 GENERAL PROCEDURE

Thoroughly study hydraulic and electronic schematics in **the Schematics section**. Check for loose connections and short circuits. Check/repair/replace each component in the Truth Table which is listed under each machine function which does not operate properly.

Determine whether the problem is mechanical (interference), electrical or hydraulic. Some functions require power at more than one solenoid.

Use the charts on the following pages to help determine the cause of a fault in your UpRight work platform

NOTE: Spike protection diodes at components have been left out of the charts to eliminate confusion.

3-3 TROUBLESHOOTING PROCEDURES

1. *Verify your problem.* Do a full function test from both platform controls and chassis controls and note all functions that are not operating correctly.
2. *Narrow the possible causes of the malfunction.* Use the troubleshooting guide to determine which components are common to all circuits that are not functioning correctly. To aid in troubleshooting, the letters following the component on the table are the same as the component's designation on the schematics.
3. *Identify the problem component.* Test components that are common to all circuits that are not functioning correctly. Remember to check wires and terminals between suspect components. Be sure to check connections to battery negative.
4. *Repair or replace component found to be faulty.*
5. *Verify that repair is complete.* Do a full function test from both the platform and chassis controls to verify that all functions are operating correctly and that the machine is performing according to specifications.

ADJUSTMENT PROCEDURES

Hydraulic settings must be checked whenever a component is repaired or replaced.

Remove counterbalance valves and "bench test" them if they are suspect.

Connect a pressure gauge of appropriate range to the test port located on the hydraulic manifold.

NOTE: Correct pressure settings are listed in the hydraulic schematic.

CHECKING PUMP PRESSURES

Remove hose from pump port and connect pressure tester.

Figure 3-1: Hydraulic Test Port

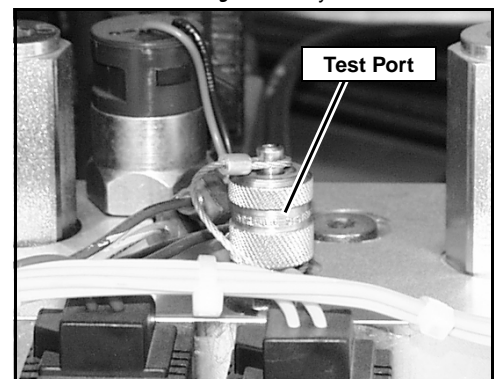

3-4 MOTOR CONTROLLER DIP SWITCH SETTINGS

SERIAL # M30176 - M30338

Figure 3-2: Controller

DEFAULT DIP SWITCH SETTINGS

The table shows the default dip switch settings on the controller box when the machine leaves the factory.

	1	2	3	4	5	6	7	8
MX15/19	OFF	ON	OFF	ON	OFF	ON	OFF	ON
SL20	ON	OFF	OFF	ON	OFF	ON	OFF	ON
TM12	OFF	OFF	OFF	ON	OFF	ON	OFF	ON
X20N	ON	OFF	OFF	ON	OFF	ON	OFF	ON
X20W	ON	OFF	OFF	ON	OFF	ON	OFF	ON
X26/32	ON	ON	OFF	ON	OFF	OFF	OFF	ON

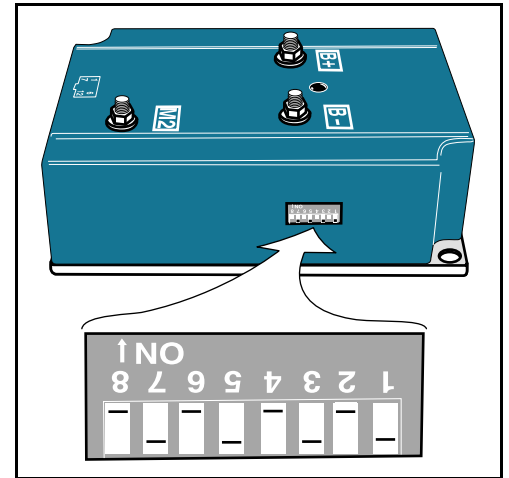

ADJUSTED DIP SWITCH SETTINGS

The following adjustments may be made to the dip switch settings.

CREEP SPEED

Switches 3 & 4 determine the elevated “creep” speed. If the machine does not operate at the specified speed at the default settings, use the following table to adjust the dip switch settings.

	3	4
1 (slowest)	OFF	OFF
2	ON	OFF
3 (default)	OFF	ON
4 (fastest)	ON	ON

DECELERATION TIME

Switches 5 & 6 determine the deceleration time. Switch 5 is for the deceleration rate while the platform is lowered. Switch 6 is for the elevated rate.

DECEL	5	6
0.24 sec.	OFF	OFF
1.27 sec.	ON	ON

3-5 I/O BOARD DIP SWITCH SETTINGS

SERIAL # M30176 - M30338

Figure 3-3: I/O Board

DEFAULT SETTINGS

The table shows the default dip switch settings on the I/O board when the machine leaves the factory.

	1	2	3	4
MX15/19	OFF	OFF	OFF	OFF
SL20	OFF	OFF	OFF	OFF
TM12	OFF	OFF	OFF	OFF
X20N	OFF	OFF	OFF	OFF
X20W	OFF	OFF	OFF	OFF
X26/32	OFF	OFF	OFF	OFF

OPTIONAL SETTINGS

Switches 3 & 4 work together to determine the optional alarm settings.

1	2	3	4	RESULT
ON				Two Speed Mode (not used)
OFF				Proportional Control
	ON			not used
	OFF			Depression Mechanism extends when platform is raised
		OFF	OFF	Down alarm only
		ON	OFF	Down and Reverse alarm
		OFF	ON	Drive and Down alarm
		ON	ON	All Motion alarm

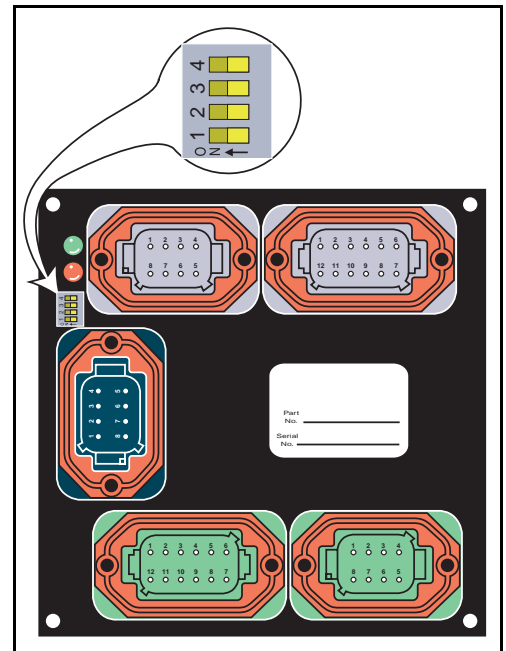

3-6 LED FAULT CODES

SERIAL # M30176 - M30338

Batteries must be fully charged before troubleshooting.

Check/Repair all connections before replacing any components

Figure 3-4: Motor Controller

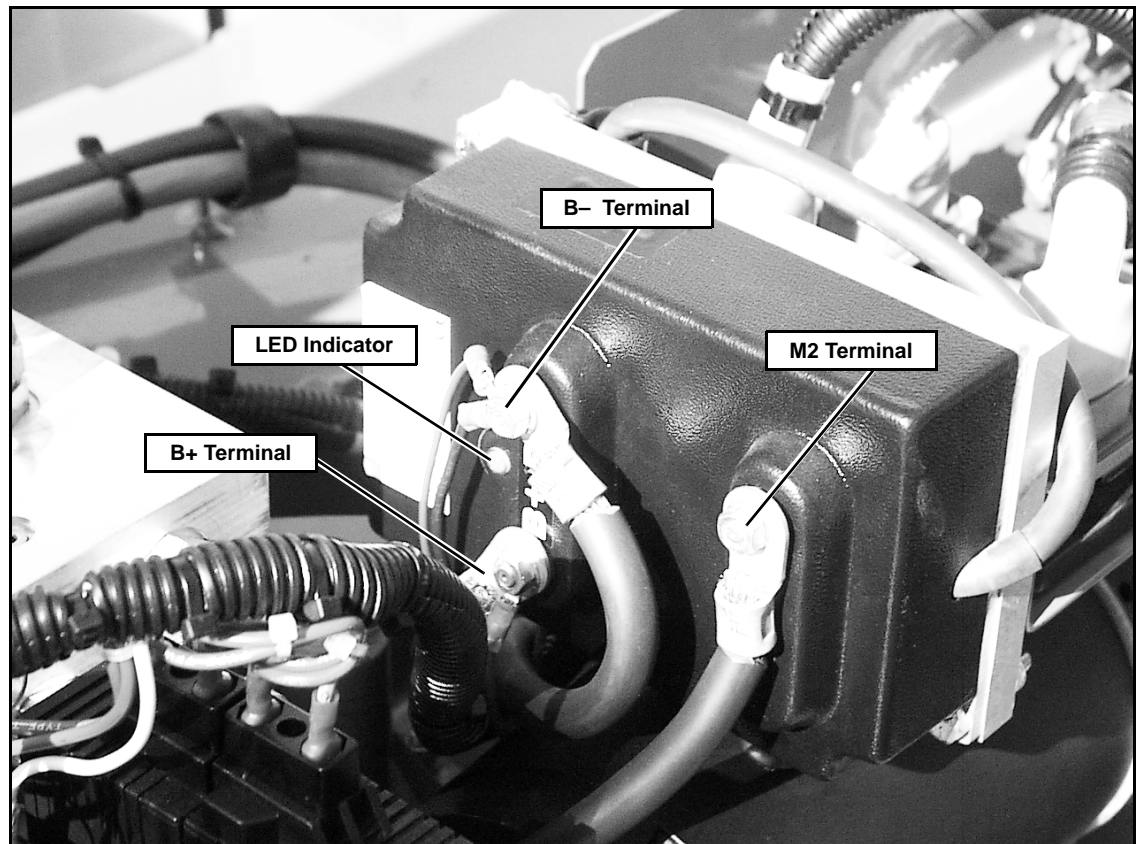

NOTE: Before dip switch settings will take effect, power must be disconnected or Emergency Stop switches must be depressed.

Table 3-1: LED Fault Codes

Flash Code	Meaning	Status	Corrective Action
LED on	Power to the controller and the controller is operational.	System is functional	None.
LED off	No power to the controller, or internal fault in the controller.	Battery cables not connected properly; Failed controller	Check battery cable connections. Replace the controller.
2 Flash	Procedural fault.	Lift, drive, or steer switch is engaged at start-up; Drive/Lift switch rotated while operating	Cycle the Control Handle through neutral to clear fault.
3 Flash	Controller senses B- at the M2 terminal.	Short circuit at the motor; M2 cable in contact with B- cable; Short circuit within controller	Check cable routing and connections. Test terminals for source of B- . Replace the controller
4 Flash	Controller senses B+ at the M2 terminal before engaging the Motor Start relay.	B+ cable routed incorrectly; M2 cable making contact with B+ cable; Motor Start relay contacts welded closed.	Check cable routing and connections. Test terminals for source of B+. Replace the Motor Start relay.
5 Flash	Controller senses open circuit at M2 after engaging the Motor Start terminal.	Cables loose or not connected; Faulty Motor Start relay	Check the cable routing and connections. Check the signal from Motor Controller to relay. Check/replace the Motor Start relay.
6 Flash	Faulty signal from Control Handle or I/O board.	Faulty Control Handle; Wiring error	If Platform Controls are affected, check/replace the Control Handle. If Chassis Controls are affected, check/replace the I/O board.
7 Flash	Battery voltage below 12V or above 45V.	Dead batteries; Bad cable connections	Check batteries and cable connections.
8 Flash	Thermal cut-off.	Controller is overheated due to overuse or other failure	Allow system to cool. Locate and repair other source of overheat.

3-7 LEDs AT I/O BOARD

SERIAL # M30176 - M30338

GREEN LED ON

The Green LED indicates that power is present at the board.

RED LED ON

The Red LED indicates a short in the system. To locate the problem;

1. Push both E-Stop switches to the OFF position.
2. Turn the Keyswitch to the OFF position, then to either Platform or Chassis.
3. Pull both E-Stop switches to the ON position.
 - The Green LED should be ON.
 - The Red LED should be OFF.
4. Perform all machine functions until the Red LED is ON. Determine which function activated the Red LED and check all components that are active for that function.

Figure 3-5: I/O Board

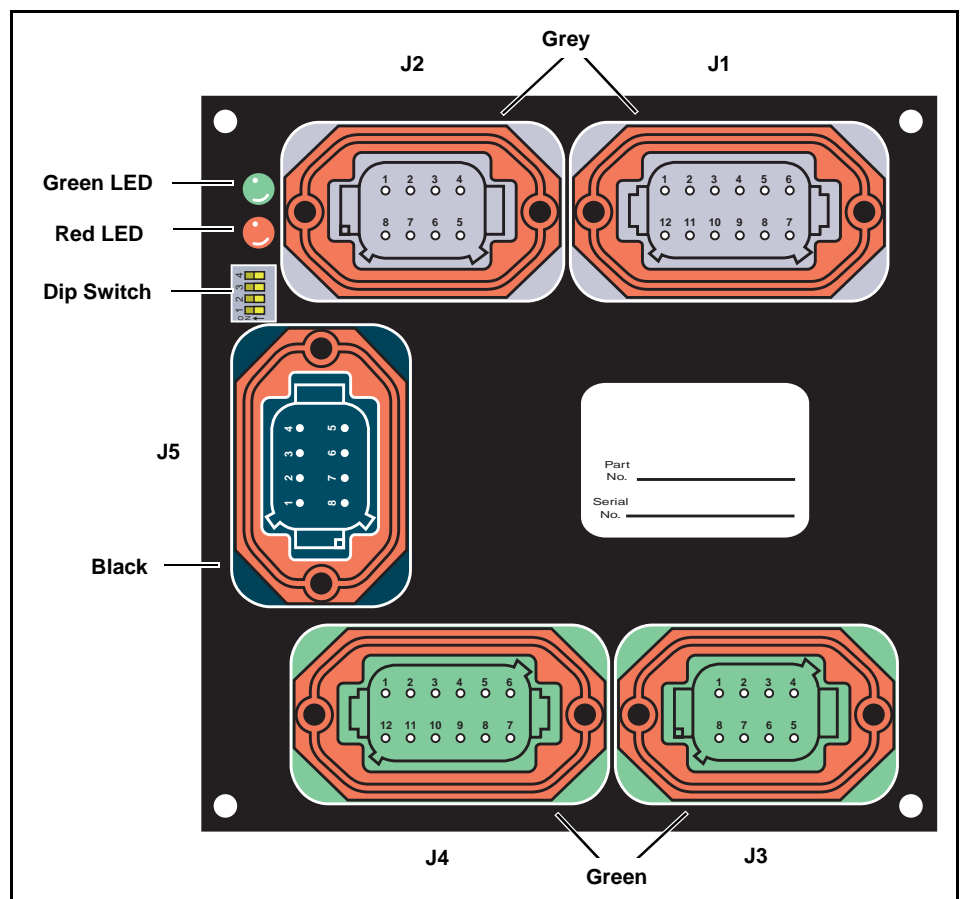

3-8 I/O BOARD INPUTS AND OUTPUTS

SERIAL # M30176 - M30338

Refer to Figure Figure 3-5: "I/O Board," on page 3-7.

PERFORM TESTS WITH FULLY CHARGED BATTERIES

Battery state of charge will affect readings.

BV = BATTERY VOLTAGE

Readings within a few volts of current battery state of charge will be called BV.

0V

0V is generally 0 up to 1 volt.

VOLTAGE READINGS FOR ELECTRONICS ARE RARELY EXACT

Many factors can affect readings, such as state of charge, voltage drops through switches (mechanical or electrical), and wires.

Be sure that both the Platform and Chassis Emergency Stop Switches are pulled out to the ON position.

All voltages are measured between the component and the B- terminal on the Motor Controller.

NOTE: For the I/O board to be powered up (Green LED illuminated), both E-Stops must be closed and either Platform Controls or Chassis Controls selected by the Keyswitch.

Table 3-2: Connector J1

PIN	PIN DESCRIPTION	CONDITION	VOLTAGE	CONTINUOUS TO PIN
J1-1	Lift input from Lift/Drive selector switch	Lift selected	BV	—
		Lift not selected	0V	
J1-2	Not Used	—	—	—
J1-3	Drive input from Lift/Drive selector switch	Drive selected	BV	—
		Drive not selected	0V	
J1-4	Lower E-Stop activation (output from I/O board when lower E-Stop is closed)	Lower E-Stop closed	BV	J4-9
		Lower E-Stop open	0V	
J1-5	Upper E-Stop activation (output to I/O board when upper E-Stop is closed)	Upper E-Stop closed	BV	J4-2
		Upper E-Stop open	0V	
J1-6	Power to Platform Controls when selected by Keyswitch	Platform Controls selected	BV	J4-10
		Platform Controls not selected	0V	
J1-7	Not Used	—	—	—
J1-8	Controller direction "A" (up/forward)	Control Handle pushed forward	20-22V	—
J1-9	Controller direction "B" (down/reverse)	Control Handle pushed forward	20-22V	—
J1-10	Speed signal from Control Handle	Signal starts high and drops proportionally as Control Handle is moved in either direction	4.3V dropping to 0.2V	—
J1-11	Steer Left input from Steering switch	Steer Left selected	23V	—
		Steer Left not selected	0V	
J1-12	Steer Right input from Steering switch	Steer Right selected	23V	—
		Steer Right not selected	0V	

Table 3-3: Connector J2

PIN	PIN DESCRIPTION	CONDITION	VOLTAGE	CONTINUOUS TO PIN
J2-1	Depression mechanism activation (extend)	Lift Up requested	0V	—
		Lift Up not requested	BV	
J2-2	Not Used	—	—	—
J2-3	24 Volt supply for solenoids	Upper & Lower E-Stops closed	BV	J4-5 & J3-3
		Upper or Lower E-Stop open	0V	
J2-4	Forward solenoid activation	Forward requested	0V	—
		Forward not requested	BV	
J2-5	Reverse solenoid activation	Reverse requested	0V	—
		Reverse not requested	BV	
J2-6	Up solenoid activation	Up requested	0V	—
		Up not requested	BV	
J2-7	Steer Left solenoid activation	Steer Left requested	0V	—
		Steer Left not requested	BV	
J2-8	Steer Right solenoid activation	Steer Right requested	0V	—
		Steer Right not requested	BV	

Table 3-4: Connector J3

PIN	PIN DESCRIPTION	CONDITION	VOLTAGE	CONTINUOUS TO PIN
J3-1	Alarm activation	Alarm sounding (out of level unit lowering, etc.)	†	—
† If the alarm is sounding because the unit is out of level, BV will drop to 0V as long as the alarm is sounding. If the alarm is sounding because the unit is lowering, there will be alternating high and low voltages (the voltages will vary).				
J3-2	Tilt Sensor output signal	Unit within Level Sensor angle	BV	—
		Unit outside Level Sensor angle	0V	
J3-3	24 Volt supply for Alarm, Tilt Sensor and solenoids,	Upper & Lower E-Stops closed	BV	J2-3 & J4-5
		Upper or Lower E-Stop open	0V	
J3-4	Input from platform down Proximity Switch	Above Proximity switch	0V	—
		Below Proximity switch	BV	
J3-5	Down solenoid activation	Down requested	0V	—
		Down not requested	BV	
J3-6	Depression mechanism activation (retract)	Drive requested	0V	—
		Drive not requested	BV	
J3-7	Not Used	—	—	—
J3-8	Battery negative supply for Tilt sensor and Proximity switch	—	B-	J4-11

Table 3-5: Connector J4

PIN	PIN DESCRIPTION	CONDITION	VOLTAGE	CONTINUOUS TO PIN
J4-1	Motor Start relay and Hourmeter activation	Drive, Lift or Steer requested	0V	—
		Drive, Lift or Steer not requested	BV	
J4-2	24 Volt supply to Keyswitch	Upper & Lower E-Stops closed	BV	—
		Upper or Lower E-Stop open	0V	
J4-3	Chassis Controls selected from Keyswitch	Chassis Controls selected	BV	—
		Chassis Controls not selected	0V	
J4-4	24 Volt supply to chassis Up/Down switch	—	‡	—
‡ Keyswitch must be held to Chassis Controls position to measure BV				
J4-5	24 Volt supply to Keyswitch	Upper & Lower E-Stops closed	BV	J2-3 & J3-3
		Upper or Lower E-Stop open	0V	
J4-6	Not Used	—	—	—
J4-7	Up signal from Chassis Controls	Up requested from Chassis Controls	BV	—
		Up not requested from Chassis Controls	0V	
J4-8	Down signal from Chassis Controls	Down requested from Chassis Controls	BV	—
		Down not requested from Chassis Controls	0V	
J4-9	Lower E-Stop activation (input to I/O board when E-Stop is closed)	Lower E-Stop closed	BV	J1-4
		Lower E-Stop open	0V	
J4-10	Power output to Platform Controls	Platform selected at Keyswitch	BV	J1-6
		Platform not selected at Keyswitch	0V	
J4-11	Battery negative supply to I/O Board	—	B-	—
J4-12	24 Volt supply to Hourmeter and Line Contactor coil	Upper & Lower E-Stops closed and Platform Controls or Chassis Controls selected	BV	—

Table 3-6: Connector J5

PIN	PIN DESCRIPTION	CONDITION	VOLTAGE	CONTINUOUS TO PIN
J5-1	24 Volt supply to EMC motor controller	Upper & Lower E-Stops closed and Platform Controls or Chassis Controls selected	BV	—
J5-2	Drive signal to EMC motor controller	Forward/Reverse requested	15V	—
		Forward/Reverse not requested	0V	
J5-3	Steer signal to EMC motor controller	Steer Right/Steer Left requested	15V	—
		Steer Right/Steer Left not requested	0V	
J5-4	Up signal to EMC motor controller	Up requested	15V	—
		Up not requested	0V	
J5-5	Speed Reduction signal to EMC motor controller	Below Proximity switch	15V - 17V	—
		Above Proximity switch	0V	
J5-6	Line Contactor activation signal	Drive, Lift or Steer requested	0V	—
		Drive, Lift or Steer not requested	BV	
J5-7	Direction enable	Forward/Reverse requested	0V	—
		Forward/Reverse not requested	4.0V - 4.3V	
J5-8	Speed signal to EMC motor controller	Signal starts high and drops proportionally as Control Handle is moved in either direction	4.3V dropping to 0.2V	—

3-9 FAULT CODES INTRODUCTION

SERIAL # M30176 - M30338

FAULT CODES INTRODUCTION

The TM12 is equipped with a fault detection system, if you have a faulty component, bad electrical connection or start up error a fault code will be displayed on the read out located on the upper control box.

FOR FAULT CODES 01 - 39

THE FOLLOWING PROCEDURE SHOULD BE FOLLOWED.

- Ensure that no selector buttons are depressed.
- Ensure that the deadman switch on the joystick is not held.
- Ensure that the joystick is in neutral.
- Ensure that the steer rocker is not activated.
- Ensure that analog rocker is in neutral.

Then re-cycle power, do this by pushing and releasing the emergency stop button. If the fault code is still displayed you may have a faulty upper or lower control box, consult the error code list to identify the problem component and replace if necessary.

FOR FAULT CODES 54 - 68

THE FOLLOWING PROCEDURE SHOULD BE FOLLOWED.

1. Check the fault code list to identify the problem component.
2. Ensure that the wiring harness is connected, secure, in good condition and fully intact.
3. Ensure that the problem component is receiving electrical signal, consult the schematics in section 6 of this manual to identify the ECU output and harness test points.
4. If no ECU output is present replace the ECU.
5. If ECU output is present but no signal is reaching the component replace the wiring harness.
6. If signal is reaching the component but the component is not functioning replace the component (refer to section 7 of this manual for part number information).

3-10 FAULT CODES

SERIAL # M30339 - M30642

- 01 – SYSTEM INITIALIZATION ERROR**
- 02 – SYSTEM COMMUNICATION ERROR**
- 22 – PLATFORM LEFT TURN SWITCH ON AT POWER-UP**
- 23 – PLATFORM RIGHT TURN SWITCH ON AT POWER-UP**
- 25 – PLATFORM HI-DRIVE SWITCH ON AT POWER-UP**
- 27 – PLATFORM LO-DRIVE SWITCH ON AT POWER-UP**
- 28 – PLATFORM LIFT SWITCH ON AT POWER-UP**
- 29 – PLATFORM JOYSTICK ENABLE SWITCH ON AT POWER-UP**
- 31 – PLATFORM JOYSTICK NOT IN NEUTRAL AT POWER-UP**
- 32 – LOWER CONTROL UP/DOWN TOGGLE ON AT POWER-UP**
- 39 – LOWER CONTROL ENABLE SWITCH ON AT POWER-UP**
- 54 – POTHOLE RETRACT COIL FAULT**
- 55 – LIFT UP COIL FAULT**
- 56 – LIFT DOWN COIL FAULT**
- 59 – STEER RIGHT COIL FAULT**
- 61 – STEER LEFT COIL FAULT**
- 66 – FORWARD COIL FAULT**
- 67 – REVERSE COIL FAULT**
- 68 – LOW BATTERY FAULT**

3-11 ELECTRIC**ALL MACHINES****Table 3-7:** Electrical Troubleshooting Table

Component	Function	Lower Controls	Upper Controls	Drive Forward	Drive Reverse	High Speed/Creep	Raise Platform	Lower Platform	Steer Left	Steer Right	Depression Mechanism Extend	Depression Mechanism Retract	Brakes	Tilt Alarm	Down Alarm	Battery Charge
Alarm--ALM																
Batteries--BAT		X	X	X	X	X	X	X	X	X	X	X	X	X	X	
Battery Charger--CHG																X
5 AMP Circuit Breaker--F1		X	X	X	X	X	X	X	X	X	X	X	X	X	X	
175 AMP Fuse--F2		X	X	X	X	X	X	X	X	X	X	X	X			
Hour Meter/Low Voltage indicator--HM																
I/O Board--I/O		X	X	X	X	X	X	X	X	X	X	X	X	X	X	
Motor Control--MC		X	X	X	X	X	X	X	X	X	X	X	X			
Motor--MOT				X	X	X	X	X	X	X	X	X	X			
Motor Relay--R1				X	X	X	X	X	X	X	X	X	X			
Chassis Emergency Stop Switch--S1		X	X	X	X	X	X	X	X	X	X	X	X	X	X	
Chassis Lift Switch--S2							X	X								
Chassis Key Switch--S3		X	X	X	X	X	X	X	X	X	X	X	X	X	X	
Lift/Drive Selector Switch--S4			X	X	X		X	X								
Platform Down Switch--S5						X										
Platform Emergency Stop Switch--S6		X	X	X	X	X	X	X	X	X	X	X	X	X	X	
Interlock Switch--S7			X	X	X	X	X	X	X							
PQ Control Handle--S8			X	X	X		X	X								
Height Limit Switch--S9							X									
Platform Steering Switch--S10									X	X						
Tilt Sensor--SNSR		X	X	X	X	X	X	X	X	X	X	X	X	X	X	
Steering Solenoid (right)--SOL1A										X						
Steering Solenoid (left)--SOL1B									X							
Platform Lift Solenoid--SOL2A							X									
Down Solenoid--SOL2B								X								
Depression Mechanism Extension Solenoid--SOL3A											X					
Depression Mechanism Retraction Solenoid--SOL3B												X				
Reverse Solenoid--SOL4A					X											
Forward Solenoid--SOL4B				X												

3-12 HYDRAULIC**ALL MACHINES****Table 3-8:** Hydraulic Troubleshooting Table

Component	Function	Lift Platform	Lower Platform	Steer Right	Steer Left	Drive Forward	Drive Reverse	Creep	Depression Mechanism Extend	Depression Mechanism Retract	Brakes
Check Valve--CV									X	X	
Steering Cylinder--CYL2				X	X						
Lift Cylinder--CYL1		X									
Depression Mechanism Cylinder--CYL3									X	X	
Brake Cylinder--CYL5											X
Priority Flow Divider--DVDR		X		X	X	X	X	X	X	X	X
Suction Strainer--FL1		X		X	X	X	X	X	X	X	
Return Filter--FL2		X		X	X	X	X	X	X	X	
Drive Motors (2)--MOT						X	X				
Pump--PMP		X		X	X	X	X	X	X	X	
Main Relief Valve--RV3		X				X	X	X	X	X	X
Steering Relief Valve--RV1				X	X						
Lift Relief Valve--RV2		X									
Orofile--OR		X	X								
Tank--TNK											
Steering Right/Left Valve--V1				X	X						
Lift Valve--V2A		X									
Down/Emergency Lowering Valve--V2B			X								
Depression Mechanism Retract Valve--V3B										X	
Depression Mechanism Extend Valve--V3A									X		
Forward/Reverse Valve--V4						X	X				
Counterbalance Valve--V5						X	X	X			X

SCHEMATICS

This section contains electrical and hydraulic power schematics and associated information for maintenance purposes.

The diagrams are to be used in conjunction with the *Troubleshooting Truth Tables* in **Section 3**. They allow understanding of the makeup and functions of the systems for checking, tracing, and faultfinding during troubleshooting analysis.

The components that comprise the electrical and hydraulic systems are given a reference designation and are explained as to function and location in the following tables.

TABLE OF CONTENTS

4-1	Electric Schematic Serial # M30176-M30338	4-2
4-2	Hydraulic Schematic Serial # M30176-M30338	4-4
4-3	Schematic (J1 Harness) Serial # M30339-M30642	4-6
4-4	Cable Assembly (J1 Harness) Serial # M30339-M30642	4-7
4-5	Electric Schematic Serial # M30339-M30642	4-8
4-6	Hydraulic Schematic Serial # M30339-M30642	4-9

4-1 ELECTRIC SCHEMATIC | SERIAL # M30176-M30338

Legend: 107016-001 Electric Schematic

DESIGNATION	NAME	FUNCTION	LOCATION
ALM	Alarm	Provides warning sound	Chassis Controls
BAT	Batteries	Provides power to work platform	Battery Tray
CHG	Battery Charger	Charges battery	Chassis
F1	5 AMP Circuit Breaker	Electrical overload protection	Chassis Controls
F2	175 AMP Fuse	Overload protection for electric motor	Chassis
HM	Hour Meter	Indicates hours of use and low battery voltage.	Chassis
I/O	I/O Board	Connection point for machine function wiring	Chassis
MC	Motor Control	Controls the speed of electric motor	Chassis
MOT	Motor	Provides power to hydraulic pump	Chassis
R1	Motor Relay	Controls the speed of the electric motor	Chassis
S1	Chassis Emergency Stop Switch	Shuts down all machine functions	Chassis Controls
S2	Chassis Lift Switch	Elevates platform	Chassis Controls
S3	Chassis Key Switch	Allows some machine functions to be initiated from ground level	Chassis Controls
S4	Proximity Switch	Provides high speed cutout	Chassis
S5	Lift/Drive Selector Switch	Activates lift or drive functions	Platform Controls
S6	Platform Emergency Stop Switch	Shuts down all machine functions	Platform Controls
S7	Interlock Switch	Safety mechanism for PQ Control Handle	Platform Controls
S8	PQ Control Handle	Proportionally controls the drive and lift functions	Platform Controls
S9	Platform Steering Switch (2)	Control left and right steering solenoids	Platform Controls
SNSR	Tilt Sensor	Activates tilt alarm	Chassis
SOL1	Steering Solenoid (right)	Shifts steering valve to the left	Hydraulic Manifold
SOL2	Steering Solenoid (left)	Shifts steering valve to the right	Hydraulic Manifold
SOL3	Platform Lift Solenoid	Raises platform	Hydraulic Manifold
SOL4	Reverse Solenoid	Shifts forward/reverse valve to reverse	Hydraulic Manifold
SOL5	Forward Solenoid	Shifts forward/reverse valve to forward	Hydraulic Manifold
SOL6	Depression Mechanism Extension Solenoid	Extends depression mechanism bars	Hydraulic Manifold
SOL7	Down Solenoid	Lowers platform	Lift Cylinder
SOL8 & SOL9	Depression Mechanism Retraction Solenoid	Retracts depression mechanism bars	Depression Mechanism cylinder

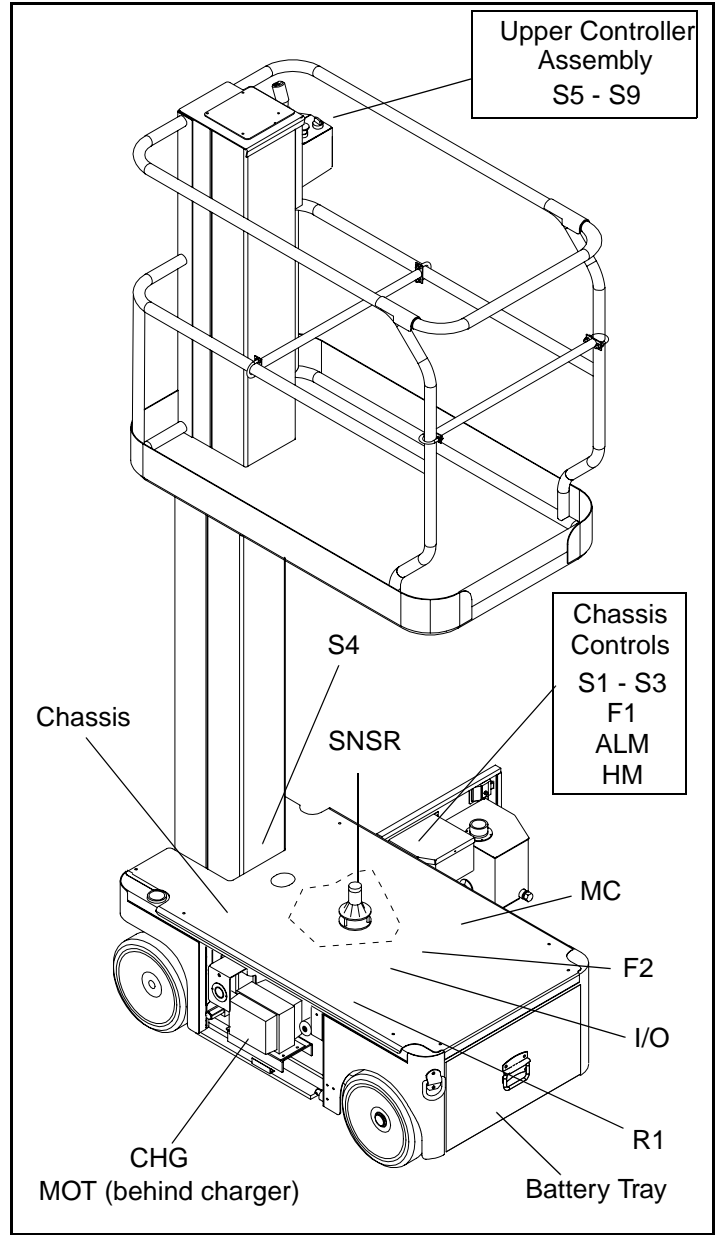

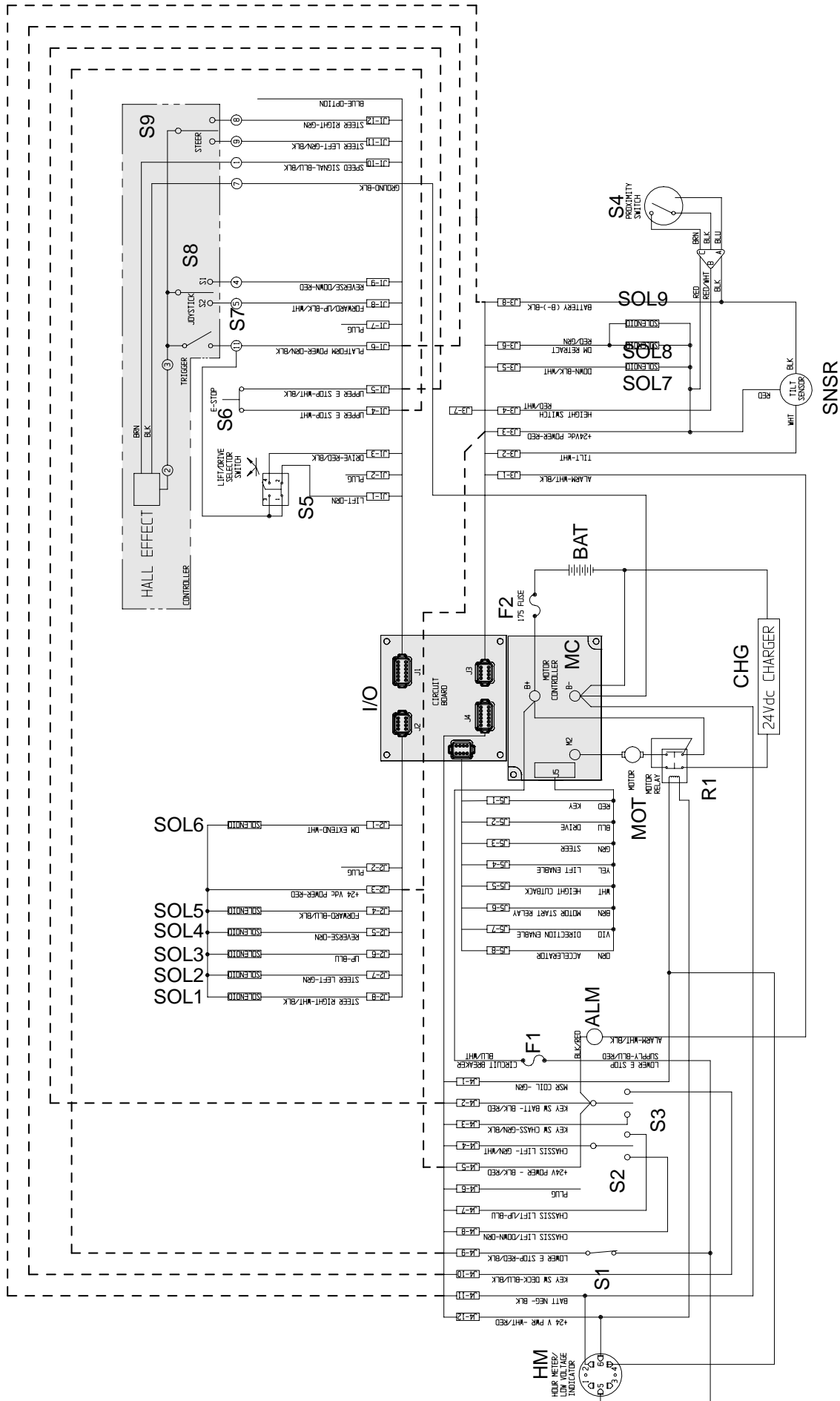

4-2 HYDRAULIC SCHEMATIC | SERIAL # M30176-M30338

Legend: 107015-001 Hydraulic Schematic Legend

DESIGNATION	NAME	FUNCTION	LOCATION
CV	Check Valve	Allows Depression Mechanism to retract in drive mode	Hydraulic Manifold
CYL1	Steering Cylinder	Provides force to turn front wheels	Mid-chassis
CYL2	Lift Cylinder	Provides force to lift platform	Mounted inside Mast Assembly
CYL3	Depression Mechanism Cylinders (2)	Extends or retracts DM bar	Mid-chassis
CYL4	Brake Cylinder	Stops machine from moving while parked	Battery Compartment
FC	Flow Control	Control Elevation Rate	Flow Control Valve
FD	Priority Flow Divider	Provides priority oil flow to steering	Hydraulic Manifold
FL1	Suction Strainer	Traps particles in hydraulic tank	Inside hydraulic tank at outlet
FL2	Return Filter	Filters oil returning to tank	Left side, rear of Charger
MOT	Drive Motors (2)	Provides tractive effort to move platform	Front Motor Mounts
ORF	Down Orifice	Control descent rate	Lift Cylinder
PMP	Pump	Provides hydraulic pressure for all functions	On Electric motor, left side, behind charger
RV1	Main Relief Valve	Provides pressure protection to pump.	Hydraulic Manifold
RV2	Steering Relief Valve	Provides pressure protection to pump and steering components when steering	Hydraulic Manifold
TNK	Tank	Holds hydraulic oil	Right Side Door
V1	Steering Right/Left Valve	Provides directional control for steering	Hydraulic Manifold
V2	Lift Valve	Provides oil control for drive or lift functions	Hydraulic Manifold
V3	Down/Emergency Lowering Valve	Allows oil to return to tank; manually operated for emergency lowering	Lift Cylinder
V4	Depression mechanism Retract Valve	Provides oil control for DM bar	DM Cylinder
V5	Depression Mechanism Extend Valve	Provides oil control for DM bar	Hydraulic Manifold
V6	Forward/Reverse Valve	Provides oil control for drive or lift functions	Hydraulic Manifold
V7	Counterbalance Valve	Prevents machine from running away on slopes; cushions stops	Hydraulic Manifold

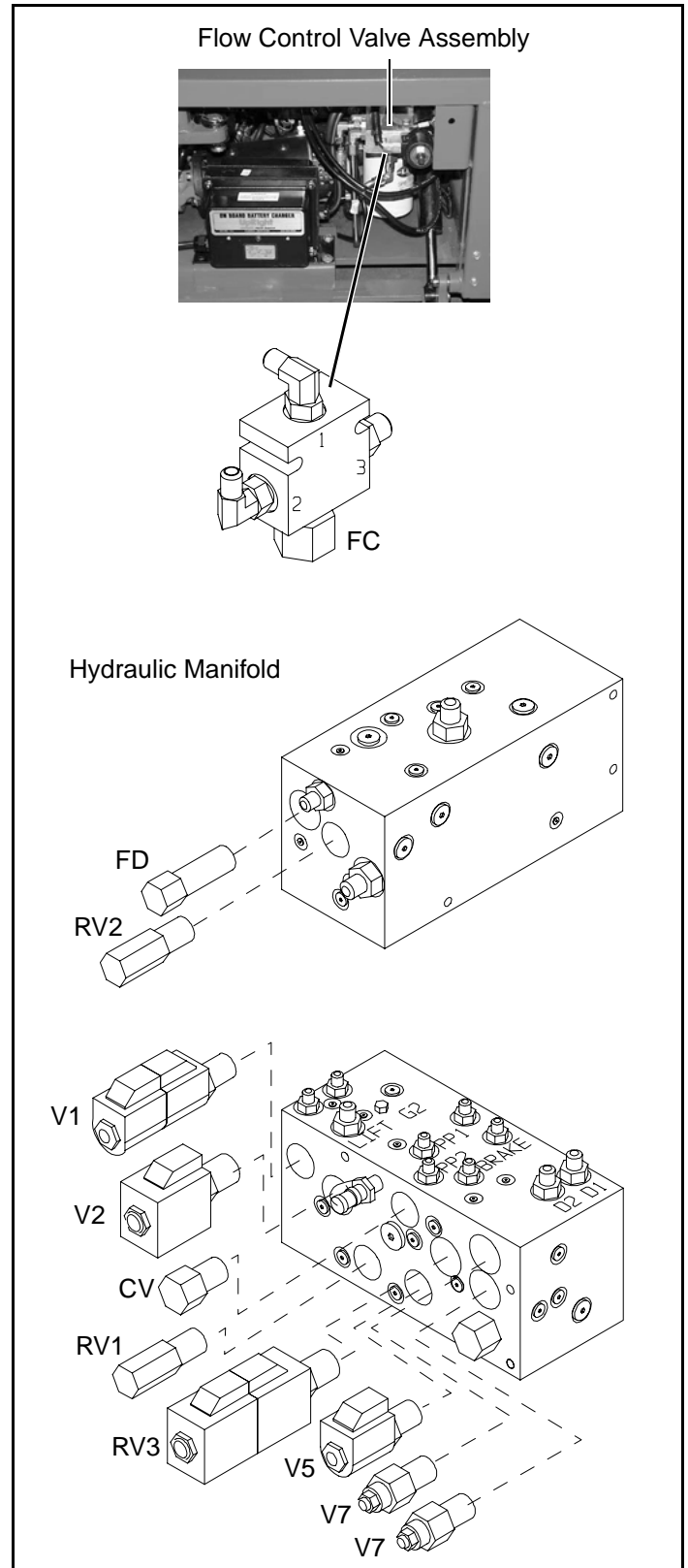

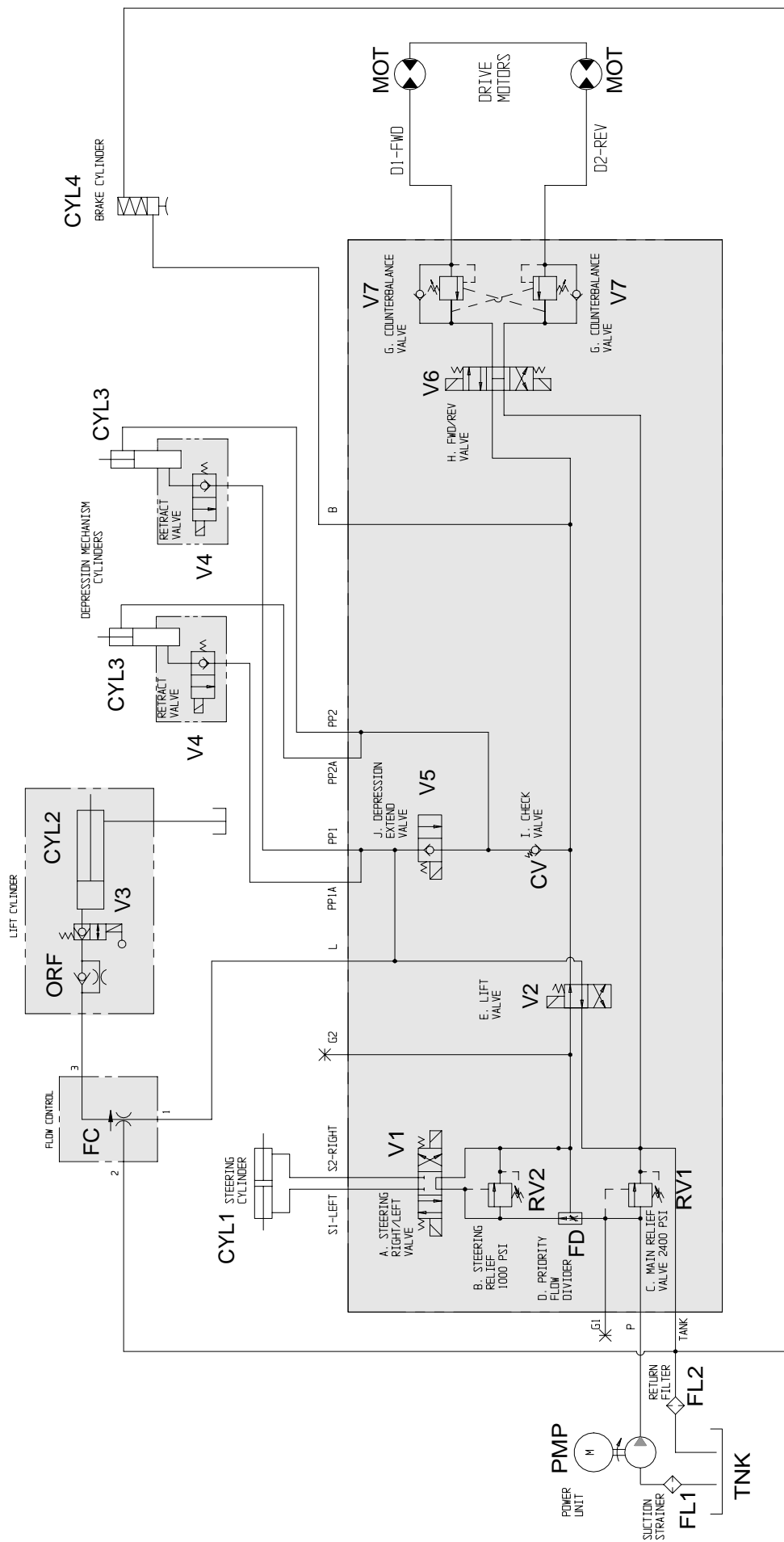

4-3 SCHEMATIC (J1 HARNESS) | SERIAL # M30339-M30642

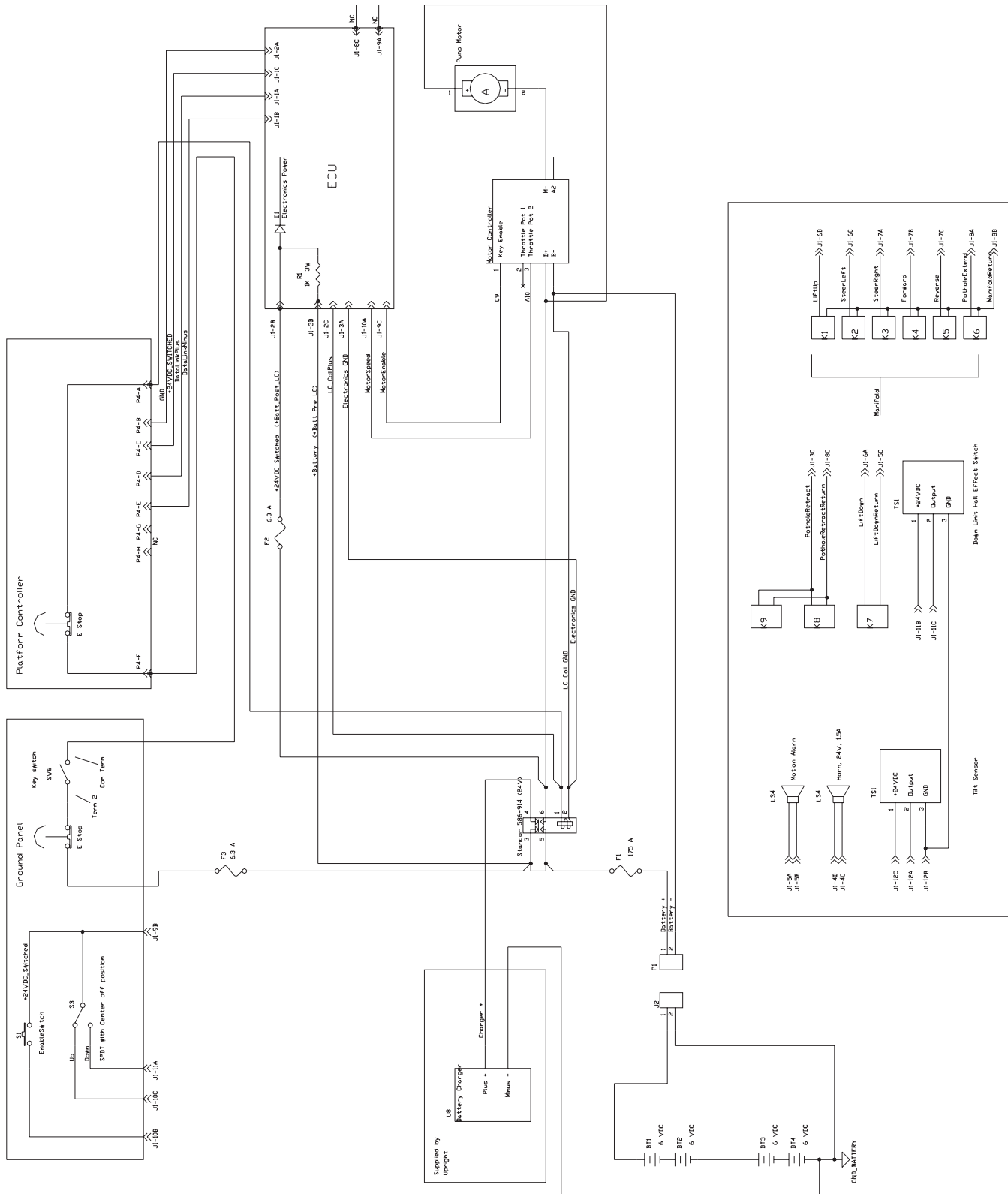

4-4 CABLE ASSEMBLY (J1 HARNESS) | SERIAL # M30339-M30642

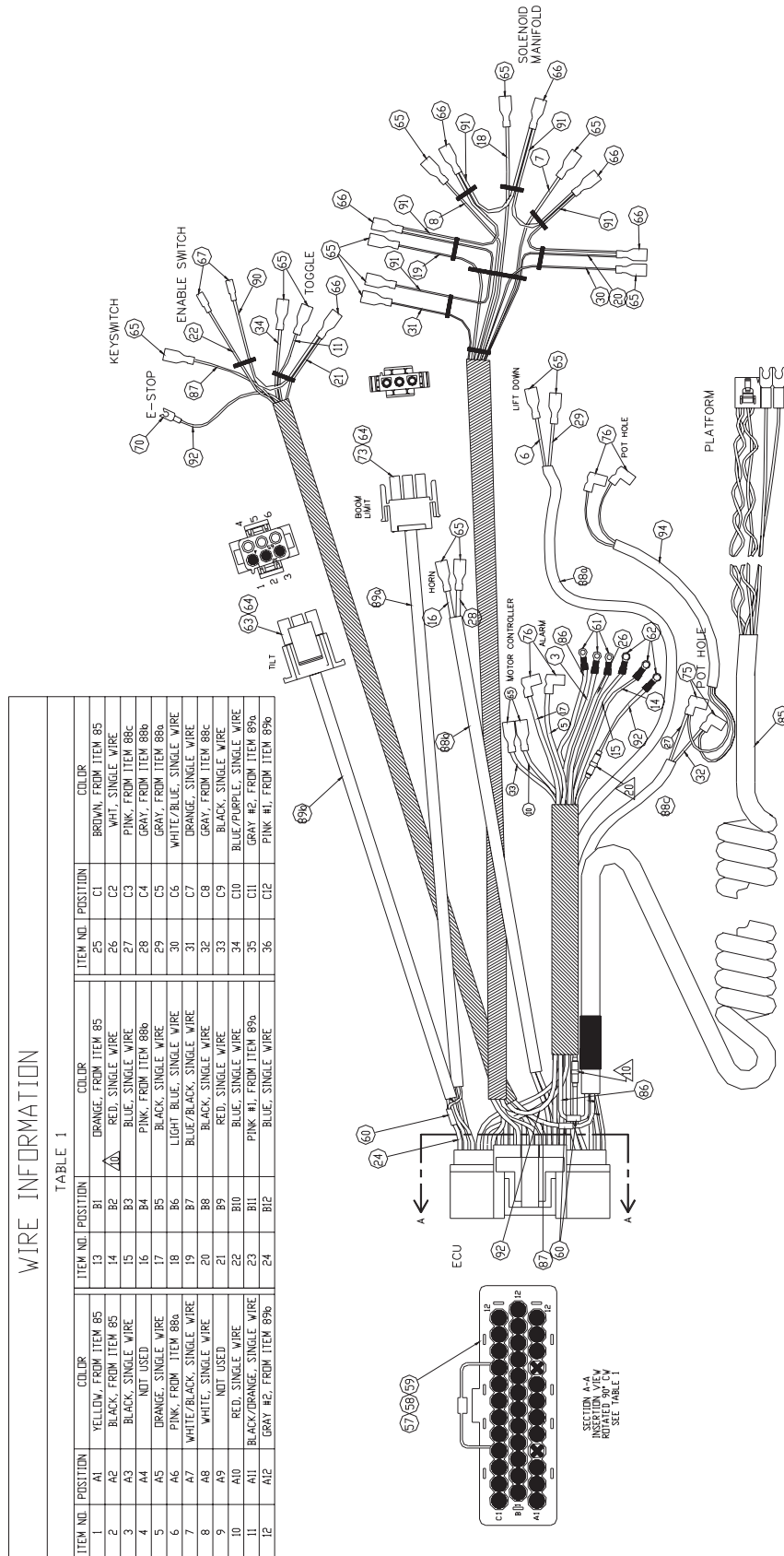

WIRE INFORMATION

TABLE 1

ITEM NO.	POSITION	COLOR	ITEM NO.	POSITION	COLOR
1	A1	YELLOW, FROM ITEM 65	25	C1	BROWN, FROM ITEM 85
2	A2	BLACK, FROM ITEM 85	26	C2	WHT. SINGLE WIRE
3	A3	BLACK, SINGLE WIRE	27	C3	PINK, FROM ITEM 88c
4	A4	NOT USED	28	C4	GRAY, FROM ITEM 88b
5	A5	DRANGE, SINGLE WIRE	29	C5	GRAY, FROM ITEM 88a
6	A6	PINK, FROM ITEM 88a	30	C6	WHITE/BLUE, SINGLE WIRE
7	A7	WHITE/BLACK, SINGLE WIRE	31	C7	DRANGE, SINGLE WIRE
8	A8	WHITE, SINGLE WIRE	32	C8	GRAY, FROM ITEM 88c
9	A9	NOT USED	33	C9	BLACK, SINGLE WIRE
10	A10	RED, SINGLE WIRE	34	C10	BLUE/PURPLE, SINGLE WIRE
11	A11	BLACK/DRANGE, SINGLE WIRE	35	C11	GRAY #2, FROM ITEM 89a
12	A12	GRAY #2, FROM ITEM 89b	36	C12	PINK #1, FROM ITEM 89b

4-5 ELECTRIC SCHEMATIC | SERIAL # M30339-M30642

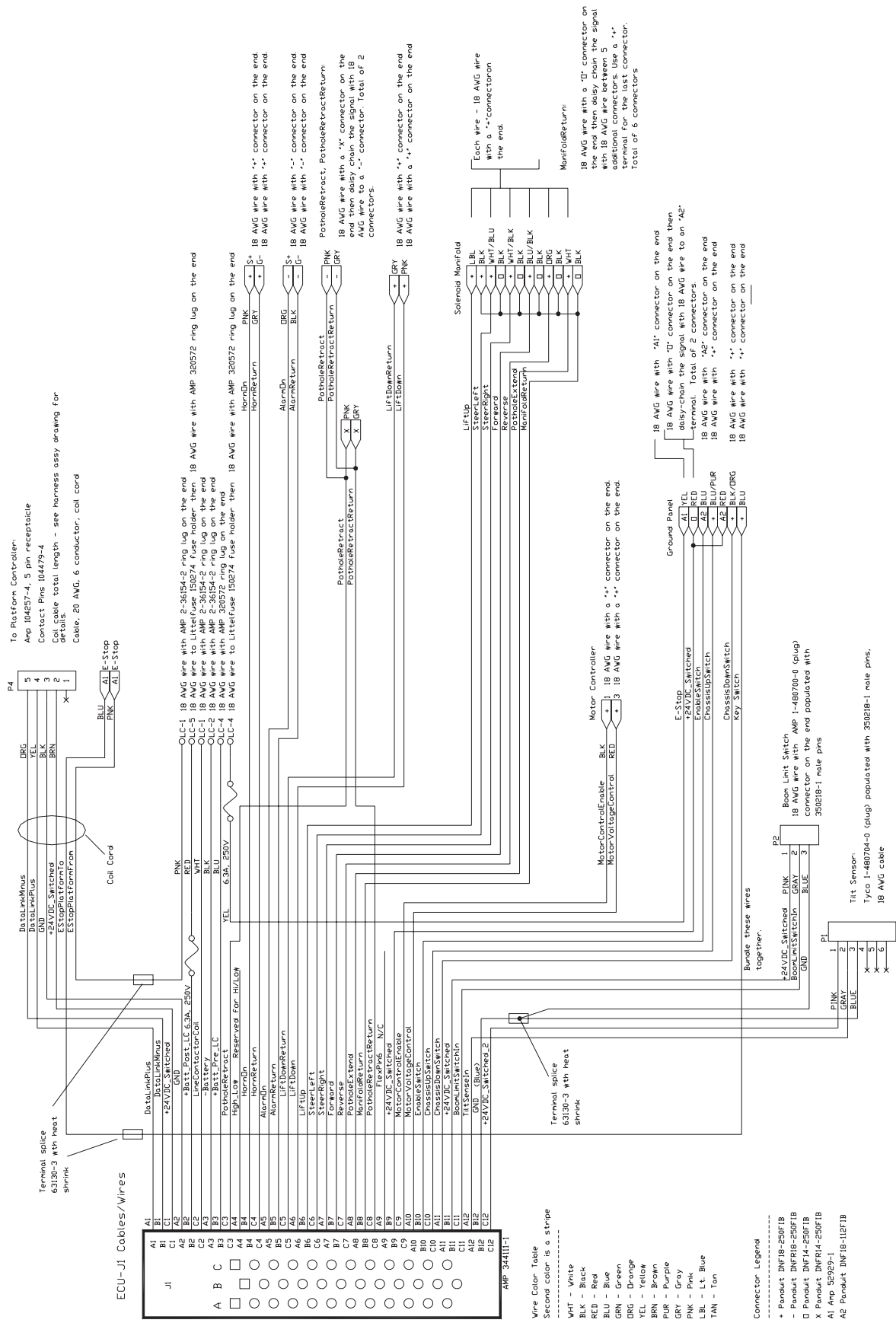

4-6 HYDRAULIC SCHEMATIC | SERIAL # M30339-M30642

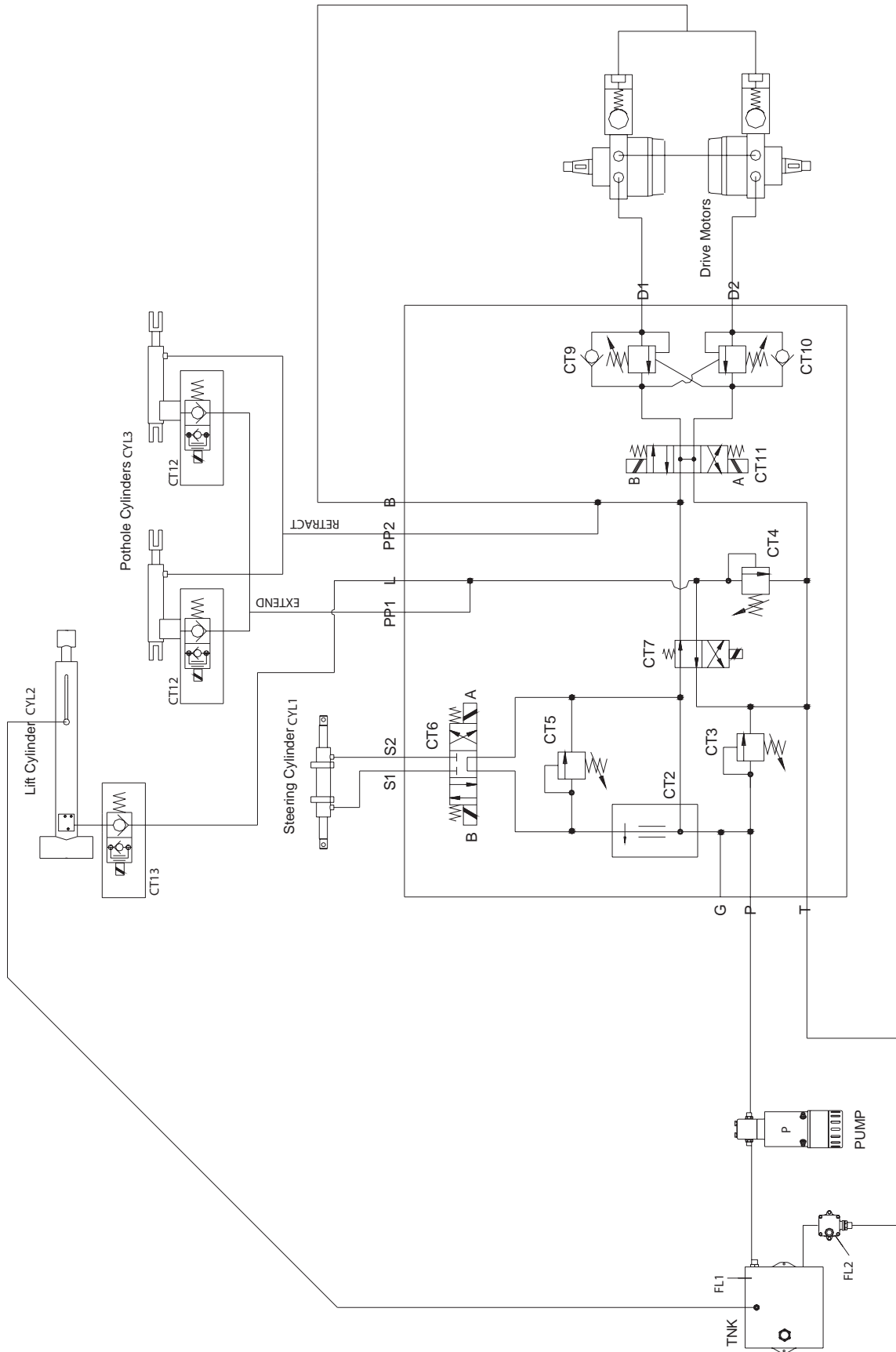

NOTES:

PARTS MANUAL

This document lists and illustrates the replaceable assemblies and parts of this product, as manufactured by *Ui* Distribution America, Inc. Each parts list contains the component parts for that assembly. Each parts list contains the component parts for that assembly.

CONTENTS

Final Assembly 107000-000 Serial # M30176-M30338 	2	Lift Cylinder 107060-001	27
Basic Assembly 107001-001	6	Brake\Steer Cylinder 065397-003	28
Chassis Assembly, 1 of 4 107002-010	8	Depression Cylinder 113053-000	29
Chassis Assembly, 2 of 4 107002-010	9	Drive Relief Valve Assembly 107006-000 Serial # M30176-M30338 	30
Chassis Assembly, 3 of 4 107002-010	10	Flow Control Valve 107061-000 Serial # M30176-M30338 	31
Chassis Assembly, 4 of 4 107002-010	11	Hydraulic Tank Assembly 107066-000	32
Hose Kit 107011-020 Serial # M30176-M30338 	12	Label Kit 107012-010 Serial # M30176-M30338 	33
Hose Kit 505007-000 Serial # M30339-M30642 	14	Voltage/Hourmeter Option 107032-000 Serial # M30176-M30338 	34
Control Valve Assembly 101120-021 Serial # M30176-M30338 	16	Lift Overload Option 107030-000 Serial # M30176-M30338 	35
Control Valve Assembly 503800-000 Serial # M30339-M30642 	17	Horn Option 107031-000 Serial # M30176-M30338 	36
Controller Assembly 107010-000 Serial # M30176-M30338 	18	Hydraulic Schematic 107015-001 Serial # M30176-M30338 	37
PQ Controller 065512-000 Serial # M30176-M30338 	19	Electrical Schematic 107016-000 Serial # M30176-M30338 	38
Electrical Box Assembly 107008-000 Serial # M30176-M30338 	20	ITT Electrical Schematic Serial # M30339-M30642 	39
Level Sensor Wire Assembly 029945-020	21	ITT Controller Serial # M30339-M30642 	40
Control Cable 107009-000 Serial # M30176-M30338 	22	ITT Controller Assembly Serial # M30339-M30642 	42
Lower Control Cable 107193-000 Serial # M30176-M30338 	23	ECU Serial # M30339-M30642 	43
Chassis Control Cable 107194-001 Serial # M30176-M30338 	24	ITT Control Cable Assembly Serial # M30339-M30642 	44
Capacitor Harness 107054-001 Serial # M30176-M30338 	25	ITT Universal Compartment Serial # M30339-M30642 	46
Valve Block Cable 107192-000 Serial # M30176-M30338 	26		

Final Assembly

107000-000 | Serial # M30176-M30338 |

ITEM	PART NO.	DESCRIPTION	QTY	ITEM	PART NO.	DESCRIPTION	QTY
1	065543-000	COVER 4M	1	28	011829-006	BOLT 1/4-20UNC CARRIAGE X 3/4	8
2	065536-000	TOP COVER	1	29	011248-004	LOCKNUT 1/4-20UNC HEX	18
3	065580-001	PLATFORM WELDMENT	REF	30	011240-004	WASHER 1/4 DIA STD FLAT	12
4	011240-001	WASHER #6	2	31	101182-006	CABLE ASSY W/ CONNECTOR	1
5	107012-010	DECAL KIT INSTL (NOT SHOWN)	1	32	062125-016	BATTERY CABLE ASSY 5/16-3/8 X 16	2
6	107011-020	HOSE KIT (NOT SHOWN)	1	33	064195-008	BATTERY CABLE ASSY 5/16-5/16 X 8	3
7	107010-000	CONTROLLER ASSY	1	34	064195-014	BATTERY CABLE ASSY 5/16-5/16 X 14	1
8	107008-000	ELEC. BOX ASSY	1	35	014252-004	NUTSERT 1/4-20 UNC	4
9	029601-020	CONN RING 10-12 GA 1/4	2	36	064195-018	BATTERY CABLE ASSY 5/16-5/16 X 18	1
10	107001-001	BASIC ASSY	1	37	101182-005	CABLE ASSY W/ CONNECTOR	1
11	029945-030	LEVEL SENSOR ASSY	1	38	107200-000	TM WELDMENT KIT (ONLY REFERENCE)	1
12	010080-006	T-CLIP	4	39	065369-099	HOSE GUARD X 18 (NOT SHOWN-SEE HOSE KIT)	2
13	069199-001	BATTERY CHARGER	1	40	063133-005	GUARD CHAIN ASSY	1
14	010154-001	COVER BATTERY TERMINAL	8	41	107197-000	PLATE - CHAIN COVER	1
15	015796-000	BATTERY 6V	4	42	029961-000	RECEPTACLE	1
16	107009-000	CONTROL CABLE ASSY	1	43	011715-006	SCREW MACH #6-32 RD HD X 3/4 LG	2
17	013919-018	CLAMP	2	44	011248-047	NUT #6-32 ESNA	2
18	107192-000	VALVE BLOCK CABLE ASSY	1	45	029961-001	SEAL	1
19	107193-000	LOWER CONTROL CABLE ASSY	1	46	107081-000	WELDMENT BALLAST	2
20	107194-001	CHASSIS CABLE ASSY	1	47	107015-010	HYD SCHM	REF
21	011240-005	WASHER 5/16 STD FLAT	4	48	107016-000	ELEC SCHM	REF
22	011248-005	LOCKNUT 5/16-18UNC HEX	2	50	110010-000	SPECIFICATION SHEET	REF
23	011253-006	SCREW 5/16-18UNC HHC X 3/4	2	51	011252-012	SCREW 1/4-20 X 1 1/2	2
24	026616-008	NIPPLE 1 CHASE	1	53	060540-001	DOCUMENTATION KIT	1
25	029939-004	LOCKNUT 1 NPT	1	56	060577-004	ANSI MANUAL	1
26	013923-004	SCREW #10 SLFTP X 1/2	8	57	107098-100	OPERATOR MANUAL	1
27	011252-006	SCREW 1/4-20UNC HHC X 3/4	6	58	010076-000	MANUAL CASE	1

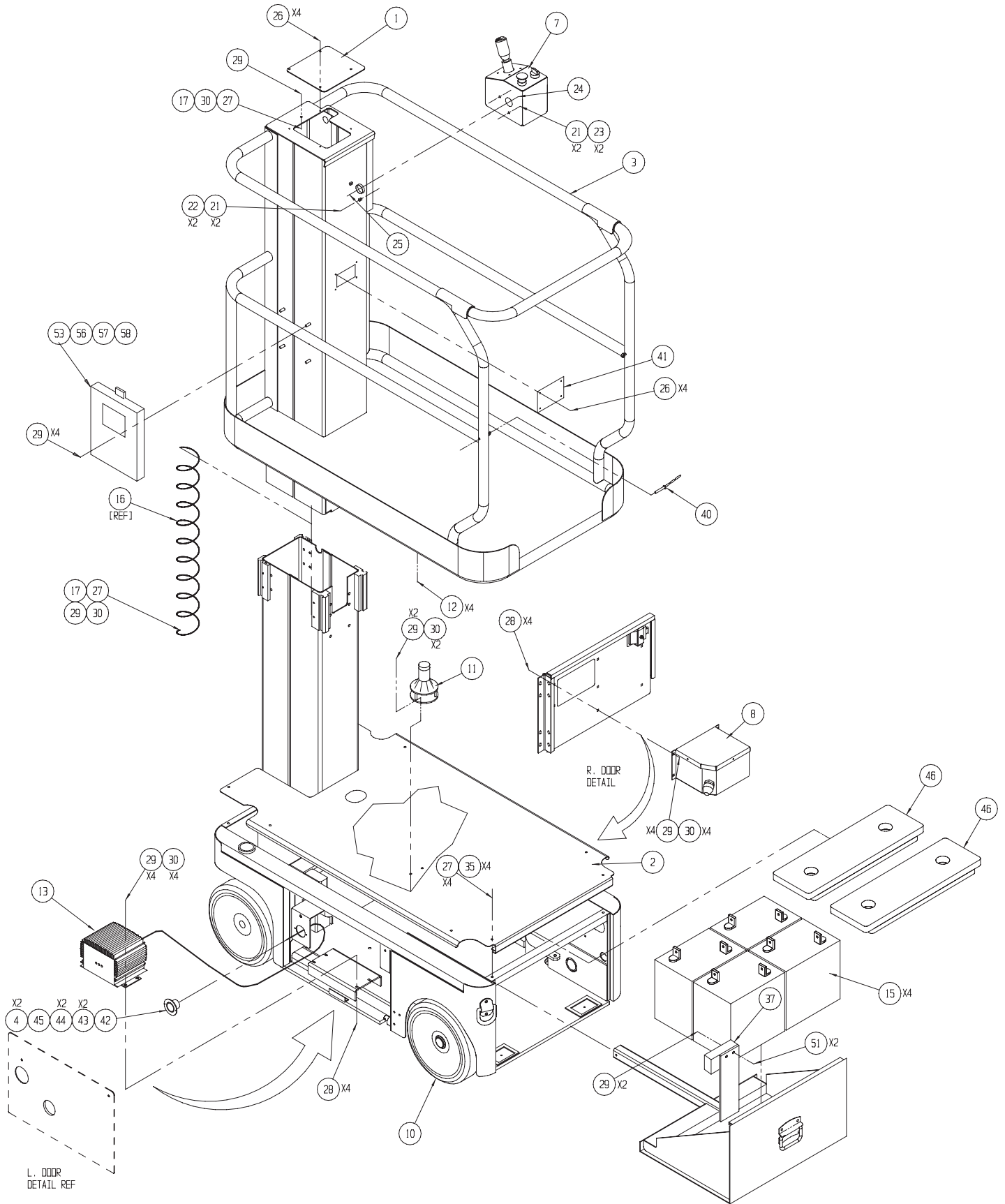

Drawing # 1 of 2

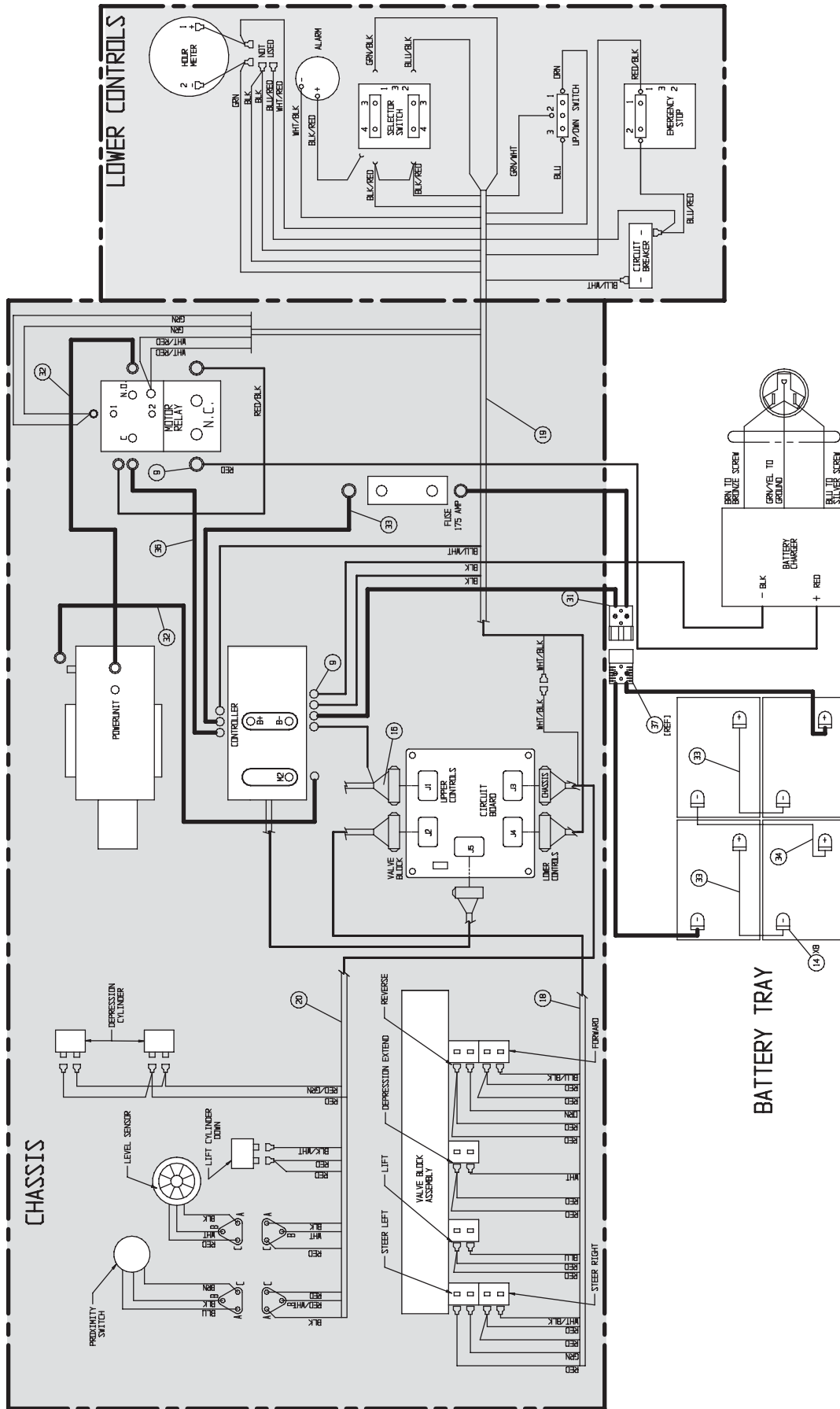

NOTES:

Basic Assembly

107001-001

ITEM	PART NO.	DESCRIPTION	QTY	ITEM	PART NO.	DESCRIPTION	QTY
1	065562-001	INNER MOUNT	2	28	011828-010	SCREW, 1/4-20 X 1 1/4 FH	2
2	065561-001	ANCHOR INNER	2	29	011821-006	SCREW, 1/4-20 X 3/4 BH	6
3	107082-000	ADAPTER 6MB-6MJ X 9"	1	30	012553-012	SCREW 1/4-20UNC SOC HD x 1 1/2	2
4	065542-001	OUTER ANCHOR	1	32	011253-004	SCREW 5/16-18UNC HHC X 1/2	6
5	065540-000	OUTER MOUNT	2	33	013315-009	RING RETAINING	1
6	065539-001	OUTER AXLE	1	35	011248-006	LOCKNUT 3/8-16UNC HEX	2
7	065538-001	INNER AXLE	1	36	011248-008	LOCKNUT 1/2-13UNC HEX	1
8	065491-001	SECOND INNER MAST WEDMENT 4M	1	37	011256-016	SCREW 1/2-13UNC HHC X 2	1
9	065488-001	LOWER INNER MAST WELDMENT	1	38	013923-004	SCREW #10-ABHWH X 1/2	44
10	065485-004	BASE MAST WELDMENT	1	39	012553-010	SCREW 1/4-20UNC SOC HD x 1 1/4	2
11	065450-001	CYL. BAR & PAD WELDMENT	1	41	012553-006	SCREW 1/4-20UNC SOC HD X 3/4	12
12	107002-010	CHASSIS ASSY	1	42	026553-001	POP-RIVET 3/16 X 1/8 GRIP	4
13	107060-001	LIFT CYLINDER ASSY	1	43	011264-210	SCREW HHC GR8 3/8-24 UNF X 1 1/4	9
14	065389-000	FRONT PAD	12	44	011735-005	ROLL PIN 1/8 x 5/8	6
15	065388-000	REAR PAD	12	45	011751-006	COTTER PIN 1/16 X 3/4	4
16	065387-001	PULLEY OUTER	1	47	011239-006	WASHER, FLAT ASTM A325 3/8	18
17	065386-001	PULLEY INNER	1	48	011261-106	NUT, HEX GR8 3/8-24 UNF	9
18	065383-001	PIN	3	49	013949-003	WASHER #10 EXT. STAR	44
19	065382-001	ANCHOR PIN	2	51	011240-006	WASHER 3/8 STD FLAT	4
22	062642-019	BEARING 7/8 ID X 3/4 LG	2	52	011254-008	SCREW, HHC. 3/8-16 X 1	2
23	062167-103	CHAIN LEAF	4	53	069040-001	THREADED STUD 1/4-28 X 2	1
24	065580-001	PLATFORM WELDMENT	1	54	069041-000	KNOB - RED	1
25	065366-020	SWITCH, PROXIMITY ASSY	1	55	107083-000	FITTING 1/8 NPT - 1/4 TUBE 90°	1
26	013336-011	GREASE ZERK	4	56	020495-004	NUT, JAM 1/4-28	2

NOTES:

- 1. USE LOCKTITE PRIMER #770 & RETAINER #405 FOR ALL SCREWS ATTACHING PADS (14 & 15) TO MAST SECTIONS.
- 2. USE LOCKTITE #242 FOR CAP SCREWS ATTACHING MOUNTS TO MAST SECTIONS.
- 3. IMPORTANT: FOLLOW ALL LOCKTITE INSTRUCTIONS ESPECIALLY CURE TIMES.
- 4. MATCH DRILL #3 TAP 1/4-20 (4) PLC'S

↑
UP

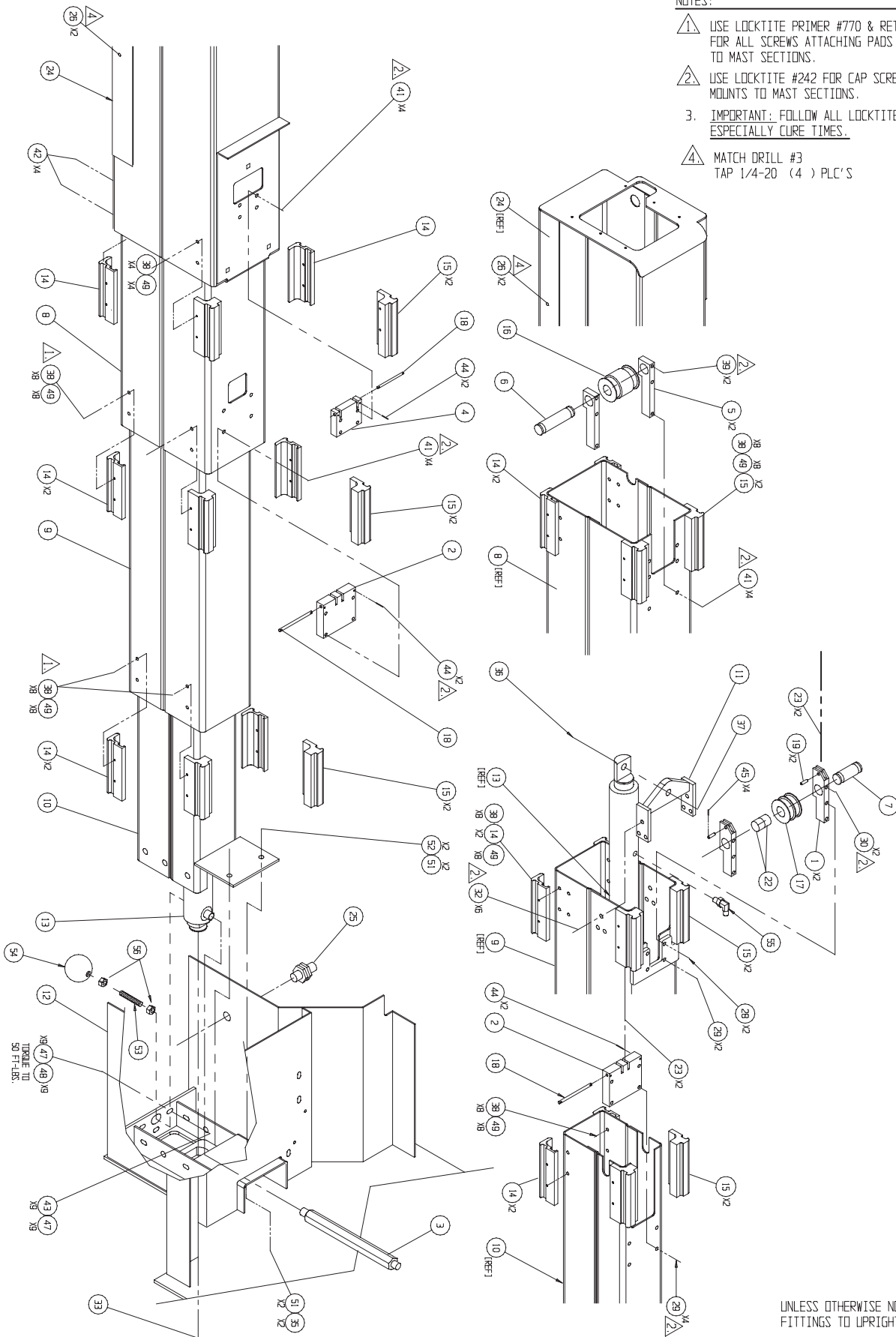

Chassis Assembly, 1 of 4

107002-010

ITEM	PART NO.	DESCRIPTION	QTY
1	107133-000	CHASSIS WELDMENT TM12	1
2	065465-000	BATTERY PAN WELDMENT	1
3	065472-000	SHOE PARK BRAKE	2
5	065384-000	BRAKE BEARING	2
6	011252-004	SCREW HHC 1/4-20 X 1/2 LG	4
8	107131-002	CHASSIS ACCESS PANEL	1
10	107153-000	BRACKET CHARGER CORD	1
15	065532-000	FRONT COVER	1
16	010121-010	SPRING COMPRESSION	1
17	065474-000	TENSION BAR WELDMENT	1
18	065397-003	CYLINDER ASSY	1
19	065469-000	BRAKE ACTUATOR WELDMENT	1
20	065385-000	GUIDE PAD	2
21	065380-000	SLIDE PAD	2
22	026541-016	HANDLE	1
24	061796-099	GROMMET (EDGING)	1.33
25	066509-000	WEAR PAD FT	1.3
28	026553-004	RIVET 3/16 X .250-.375 GRIP	2
29	014996-010	WASHER 5/8 SAE	2
30	011252-006	SCREW HHC 1/4-20UNC x 3/4	1

ITEM	PART NO.	DESCRIPTION	QTY
31	064397-003	NUT ACORN 10-24 NC	4
32	011709-004	SCREW MRDHD 10-24UNC x 1/2	4
33	026553-008	RIVET 3/16 X .501-.625 GRIP	2
34	011256-012	SCREW HHC 1/2-13UNC x 1 1/2	2
35	014066-006	SCREW 1/4 AB x 3/4	6
36	011248-004	NUT HEX 1/4-20 UNC	1
37	011240-004	WASHER FLAT STD 1/4	4
39	014252-004	NUTSERT 1/4-20	4
40	065569-000	LATCH PLATE	1
41	011830-006	BOLT CARRIAGE 5/16-18 x 3/4	6
42	011248-010	NUT HEX 5/8-11 UNC	1
43	011240-003	WASHER STD FLAT #10	1
44	011757-010	COTTER PIN, RUE RING, 3/4	2
45	011848-041	PIN 3/4 PIVOT	1
47	011248-005	NUT HEX 5/16-18 UNC	10
48	011240-005	WASHER FLAT STD 5/16	10
50	011240-008	WASHER 1/2 STD FLAT	2
51	011238-008	WASHER 1/2 SPLIT LOCK	2
52	010414-001	LOCKING PIN ASSY X 6	1

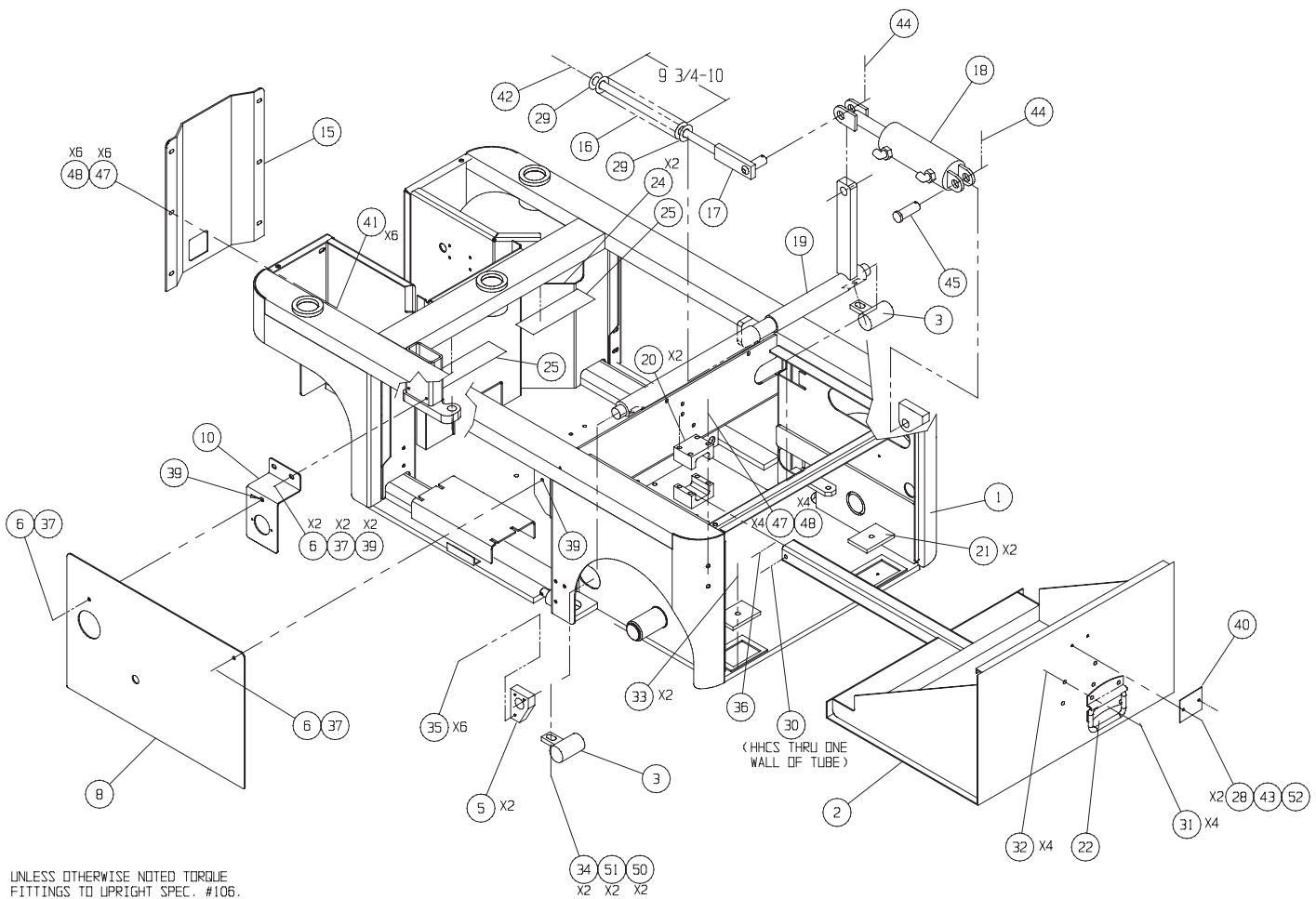

Drawing # 1 of 4

Chassis Assembly, 2 of 4

107002-010

ITEM	PART NO.	DESCRIPTION	QTY
100	101125-001	MOTOR HYDRAULIC	2
101	065393-003	WHEEL, DRIVE	2
102	107186-000	WHEEL YOKE, L.H.	1
103	107185-000	WHEEL YOKE, R.H.	1
104	065517-000	STEER LINK RH	1
105	065445-000	BELL CRANK WELDMT	1
106	065397-003	CYLINDER ASSY, BRAKE/STEER	1
108	011848-041	PIN 3/4 PIVOT	2
109	011757-010	COTTER PIN, RUE RING 3/4"	2
110	011753-012	PIN COTTER 1/8 x 1 1/2	2
111	065518-000	STEER LINK LH	1
112	011256-026	SCREW HHC GR5 1/2-13 UNC x 3 1/4	8

ITEM	PART NO.	DESCRIPTION	QTY
113	011248-008	NUT HEX 1/2-13 UNC	8
114	010092-011	WASHER THRUST 1 1/2	3
115	027931-068	BEARING 1 1/2	3
116	065534-000	STEER PIN	4
117	011736-012	ROLL PIN 3/16 DIA. x 1 1/2	4
118	011941-005	FITTING STRAIGHT 6-6S	4
119	011786-007	BUSHING MACHINE 1 1/2 I.D.	3
120	013315-009	RETAINING RING	3
121	027931-022	BEARING 3/4 I.D.	5
122	020328-002	WASHER NYLON 3/4 I.D.	4
123	011240-008	WASHER FLAT STD 1/2	8

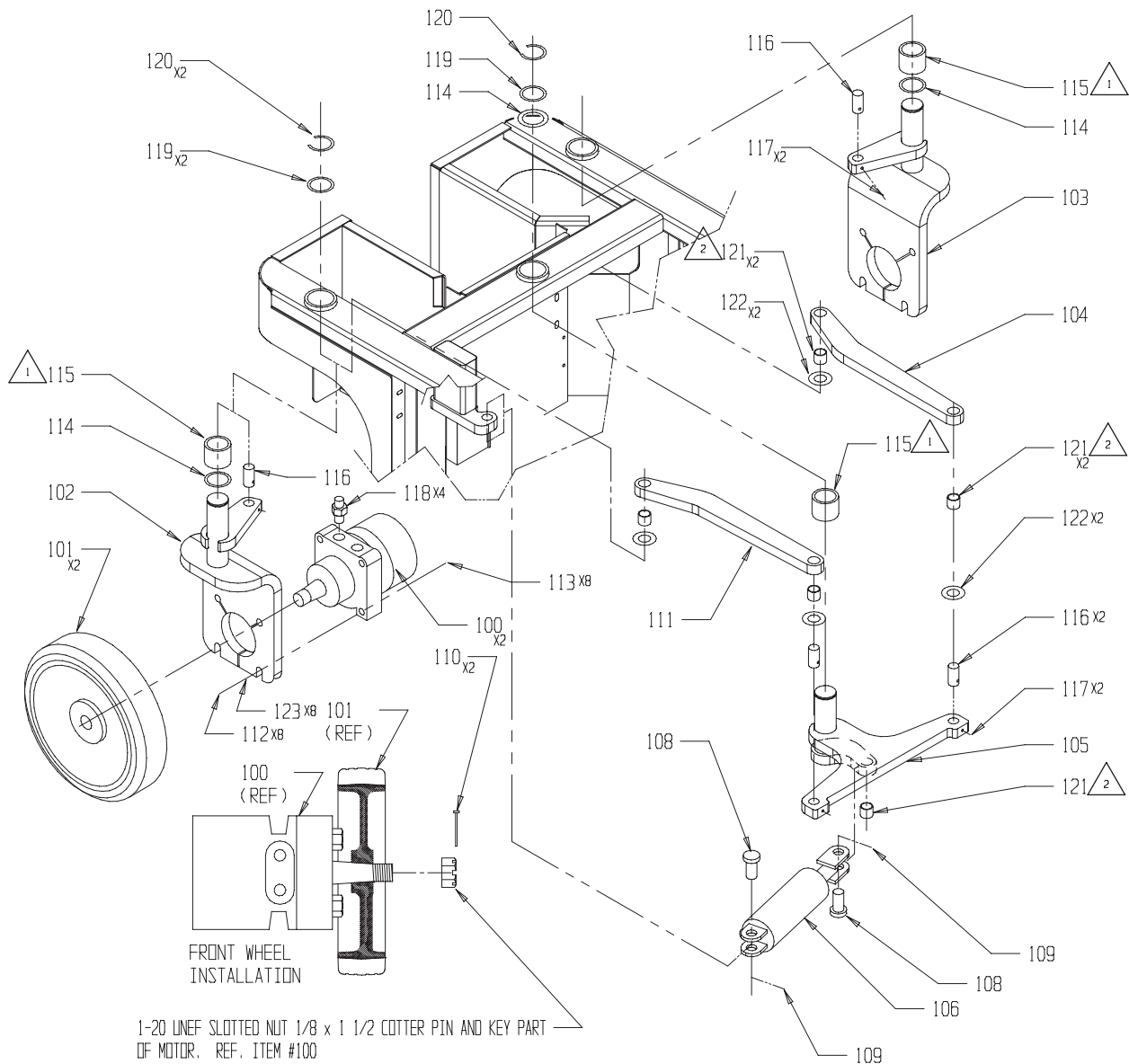

1-20 UNEF SLOTTED NUT 1/8 x 1 1/2 COTTER PIN AND KEY PART OF MOTOR. REF. ITEM #100
 CLEAN MOTOR SHAFT AND HUB BORE.
 LUBRICATE NUT FACE AND THREADS.
 TORQUE SLOTTED NUT TO 75 ±5 FT LBS BOTH WHEELS.

NOTES:

- 1 BURNISH BEARINGS AFTER ASSEMBLY TO 1.502/1.504.
- 2 BURNISH BEARINGS AFTER ASSEMBLY TO .750/.752.

UNLESS OTHERWISE NOTED TORQUE FITTING TO UPRIGHT SPEC. # 106.

Chassis Assembly, 3 of 4

107002-010

ITEM	PART NO.	DESCRIPTION	QTY
200	107133-000	CHASSIS WELDMENT	REF
201	065392-021	WHEEL IDLER	2
202	011786-014	BUSHING MACHINE 1 3/4 I.D.	4
203	013315-009	RETAINING RING 1 1/2	2
204	101120-221	CONTROL VALVE ASSEMBLY S/N M30176 - M30338	1
	503800-000	CONTROL VALVE ASSEMBLY S/N M30339 - M30642	
205	065513-000	END CAP	2
206	011823-006	SCREW 3/8-16 BUTT HD X 3/4	2
207	066046-007	MOUNT, VIBRATION	4
210	107066-000	HYD RESERVOIR ASSY	1
211	114071-000	POWER UNIT	1
212	107152-000	BRACKET, CONTROL VALVE MOUNT	1
213	065395-000	LATCH	1
214	107150-010	PANEL ASSY RH	1
215	031006-004	FITTING STR 4MB-4MJ W/.031 ORIFICE	1
217	011934-007	FITTING ELBOW 8MB-6MJ 90 FS	1

ITEM	PART NO.	DESCRIPTION	QTY
218	114072-000	FITTING 3/4 HOSE #4601-12-10-NWO	1
219	013919-010	CLAMP HOSE	1
220	011829-006	CARRIAGE BOLT 1/4-20 x 3/4	4
221	011240-004	WASHER FLAT STD 1/4	9
222	011248-004	NUT HEX 1/4-20 UNC	8
223	011252-040	SCREW HHC 1/4-20 X 5	2
225	011822-004	SCREW 5/16-18 x 1/2 BUTT HD SCREW	4
227	011240-005	WASHER FLAT 5/16	6
228	011248-005	NUT HEX 5/16-18	6
230	020733-001	FITTING TEE #4	1
231	020398-012	CLAMP	1
232	068630-000	SCREW HHC 1/4-20 X 1/2 SPRING	1
233	011252-004	SCREW HHC 1/4-20 X 1/2	1
234	011252-008	SCREW HHC 1/4-20 X 1	1
235	065369-002	HOSE GUARD	1

NOTES:

- 1. USE LOCKTIGHT 242 ON THREADS
- 2. UNLESS OTHERWISE NOTED TORQUE FITTINGS TO UPRIGHT SPEC. #106.
- 3. REPLACE EXISTING FITTING
- 4. USE CORRECT UNIT FOR SERIAL # RANGE

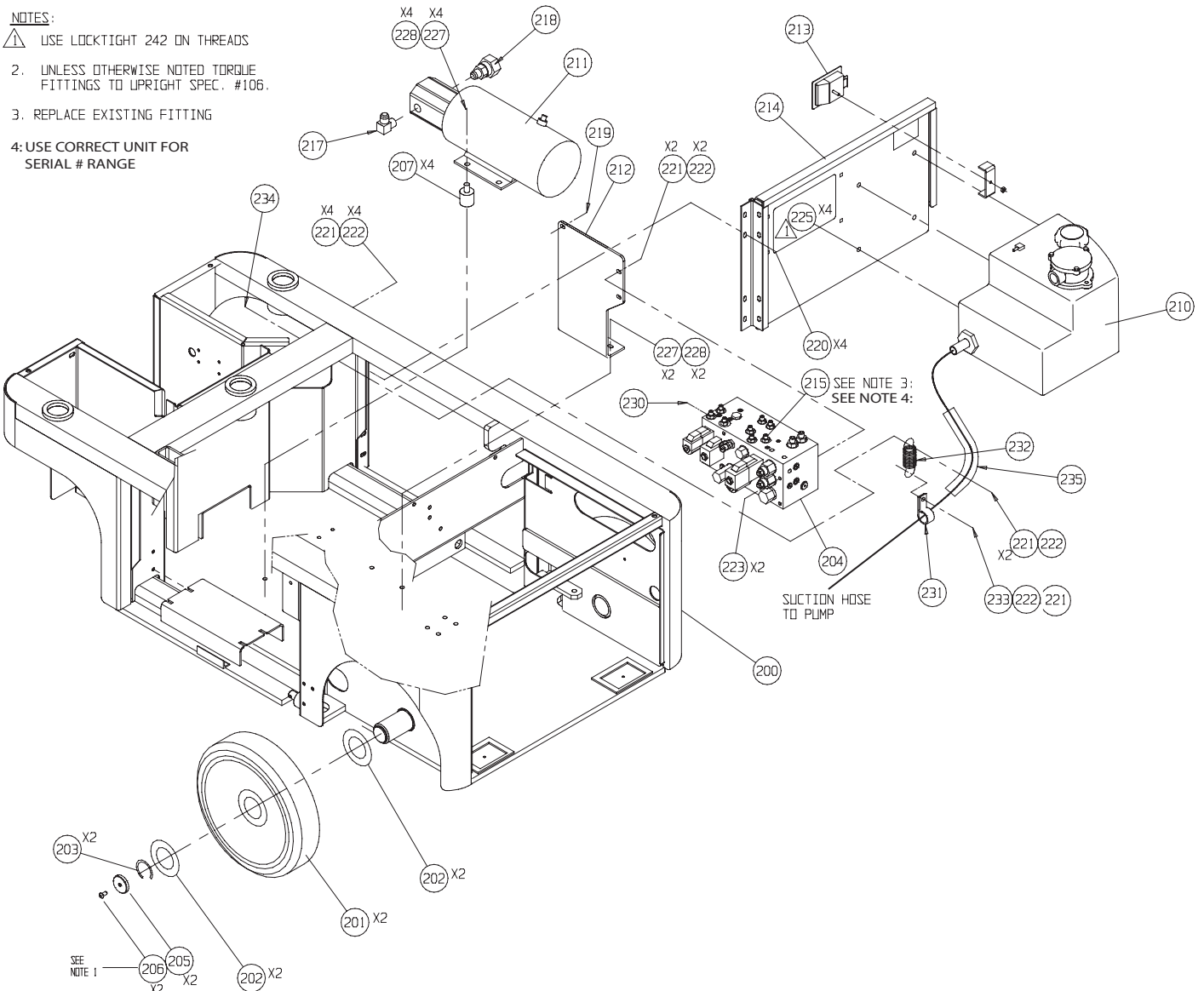

Chassis Assembly, 4 of 4

107002-010

ITEM	PART NO.	DESCRIPTION	QTY	ITEM	PART NO.	DESCRIPTION	QTY
301	107179-000	GUARD WELDMENT-L.H.	1	323	107061-000	FLOW CONTROL VALVE ASSY	1
302	107180-000	GUARD WELDMENT-R.H.	1	326	010122-001	RELAY	1
303	027931-063	BRONZE BUSHING #AA 710-27	4	327	011248-005	NUT HEX 5/16-18	2
306	113053-000	CYLINDER DEPRESSION ASSY	2	328	011240-005	WASHER 5/16 FLAT	2
		SEAL KIT		329	011253-018	SCREW HHC 5/16-18 X 2 1/4	2
307	014996-010	WASHER 5/8 SAE	4	330	010148-001	FUSE	1
308	011757-010	COTTER PIN, 3/4 RUE RING	2	331	010149-000	FUSE BLOCK	1
310	011848-019	CLEVIS PIN 3/4 X 2 1/2	2	332	011254-008	SCREW HHC 3/8-16 X 1	8
311	011848-009	CLEVIS PIN 5/8 X 2	2	333	107080-000	BRACKET - D-RING	4
312	011757-007	COTTER PIN, 5/8 RUE RING	6	334	107080-001	D-RING	4
314	065984-000	HEATSINK PLATE S/N M30176- M30338	1	335	011248-006	NUT HEX ESNA 3/8-16	8
315	065709-001	CIRCUIT BOARD S/N M30176- M30338	1	338	011709-008	SCREW #10-24 X 1	2
316	065708-001	MOTOR CONTROL S/N M30176- M30338	1	339	011248-003	NUT HEX #10-24	2
317	011252-012	BOLT 1/4-20 UNC X 1 1/2	2	340	011240-006	WASHER 3/8 FLAT	8
318	011248-004	LOCKNUT 1/4-20 HEX	6	341	502483-000	ECU S/N M30339 - M30642	1
319	011240-004	WASHER 1/4 DIA STD FLAT	6	342	502492-000	MOTOR CONTROLLER S/N M30339 - M30642	1
320	011252-010	SCREW HHC 1/4-20 X 1 1/4	2	343	N/A	MOUNTING PLATE S/N M30339 - M30642	1
321	011252-006	SCREW HHC 1/4-20 X 3/4	2	344	502588-000	ALARM SOUNDER S/N M30339 - M30642	1

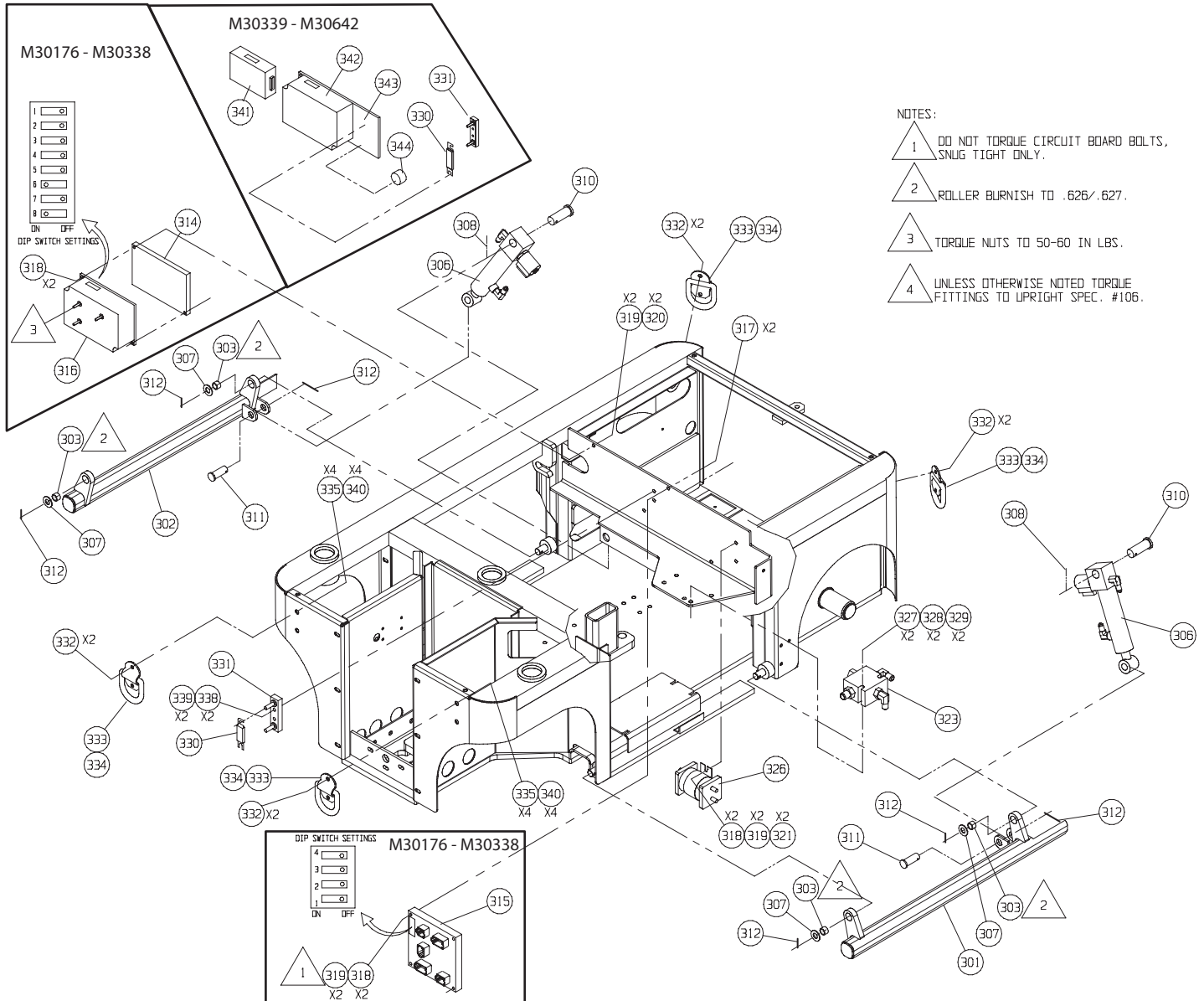

Drawing # 4 of 4

Hose Kit**107011-020 | Serial # M30176-M30338 |**

ITEM	PART NO.	DESCRIPTION	QTY
1	065419-042	HOSE ASSY 1/4 X 42 (6FJX-6FJX)	1
2	107092-041	HOSE ASSY 1/4 X 41 (6FJX-6FJX 90)	1
3	107092-025	HOSE ASSY 1/4 X 25 (6FJX-6FJX 90)	1
4	114073-024	HOSE 3/4 X 24 SUCTION (12FJX)	1
5	068965-017	HOSE ASSY 3/8 X 17 (6FJX-6FJX X 90)	1
6	068965-025	HOSE ASSY 3/8 X 25 (6FJX-6FJX X 90)	1
8	107091-047	HOSE ASSY 3/16 X 47 (4FJX-4FJX X 90)	1
10	107090-028	HOSE ASSY 1/4 X 28 (4FJX-4FJX X 90)	1
11	107090-023	HOSE ASSY 1/4 X 23 (4FJX-4FJX X 90)	1
12	107091-024	HOSE ASSY 3/16 X 24 (4FJX-4FJX X 90)	1

ITEM	PART NO.	DESCRIPTION	QTY
13	061351-025	HOSE ASSY 1/8 X 40 (4FJX-4FJX)	1
16	107313-024	HOSE ASSY 3/16 X 24(4FJX-4FJX X LONG 90)	2
17	114074-027	HOSE ASSY 3/8 X 27 (6FJX90-6G8MBX45)	1
18	020733-001	FITTING, TEE #4	REF
19	107091-024	HOSE ASSY 3/16 X 24	2
19	107091-024	(4FJX-4FJX X 90)	2
20	107085-001	TUBE BLACK POLY, 1/4" X 96"	1
21	065369-099	HOSE GUARD NYLON X 18"	REF
22	107092-044	HOSE ASSY 1/4 X 44 (6FJX-6FJX 90)	1

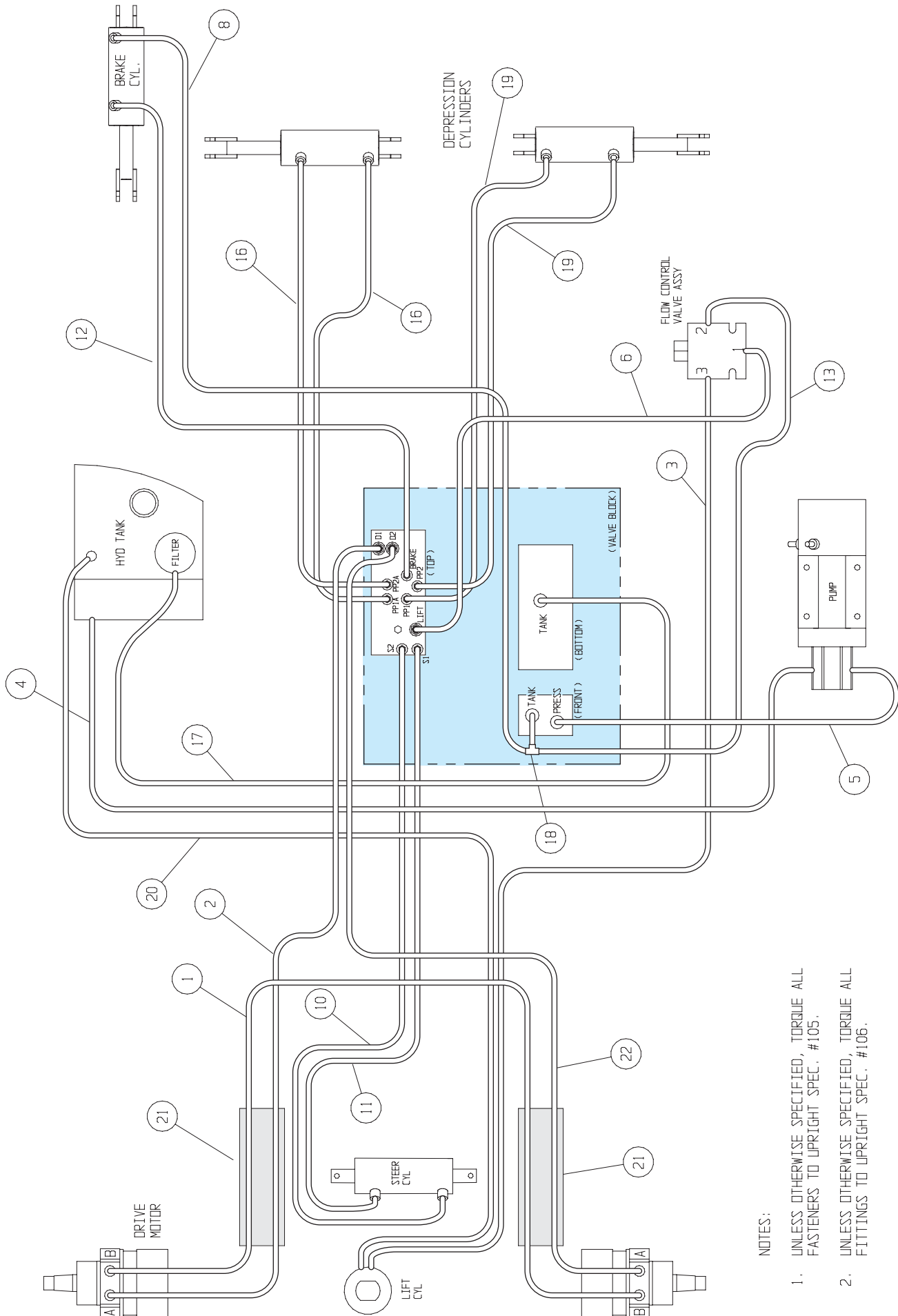

NOTES:

1. UNLESS OTHERWISE SPECIFIED, TORQUE ALL FASTENERS TO UPRIGHT SPEC. #105.
2. UNLESS OTHERWISE SPECIFIED, TORQUE ALL FITTINGS TO UPRIGHT SPEC. #106.

Hose Kit**505007-000 | Serial # M30339-M30642 |**

ITEM	PART NO.	DESCRIPTION	QTY	ITEM	PART NO.	DESCRIPTION	QTY
1	501999-000	DRIVE MOTOR	2	19	N/A	N/A	N/A
2	N/A	N/A	N/A	20	057107-000	FILTER (HYDRAULIC OIL)	1
3	505037-000	HYDRAULIC CYLINER (LIFT)	1	21	N/A	N/A	N/A
4	505101-000	HYDRAULIC HOSE (MOTOR TO MOTOR)	1	22	505107-000	HYD HOSE (BLOCK - BRAKE CYL, ANNULAR)	1
5	505099-000	HYDRAULIC HOSE (BLOCK TO MOTOR, LH) DI - LH	1	23	503800-000	HYDRAULIC MANIFOLD BLOCK	1
6	505100-000	HYDRAULIC HOSE (BLOCK TO MOTOR, RH)D2 - RH	1	24	55106-000	HYDRAULIC HOSE (DRAIN T - BRAKE FULL BORE)	1
7	505108-000	HYDRAULIC HOSE (LIFT CYL DRAIN - TANK)	1	25	505109-000	HYDRAULIC HOSE (DRAIN T - TANK)	1
8	N/A	N/A	N/A	26	505103-000	HYDRAULIC HOSE (PUMP - BLOCK, PRESSURE)	1
9	N/A	N/A	N/A	27	505102-000	HYDRAULIC HOSE (TANK - PUMP, SUCTION)	1
10	505098-000	HYDRAULIC HOSE (BLOCK TO MAIN LIFT CYL)	1	28	505095-000	HYDRAULIC HOSE (BLOCK - POTHOLE T-PIECE)	2
11	505035-000	HYDRAULIC CYLINDER, STEER / BRAKE	2	29	505105-000	HYDRAULIC HOSE (FILTER - TANK, RETURN)	1
12	505118-000	HYDRAULIC HOSE(BLOCK - STEER CYL, FULL B)	1	30	505096-000	HYDRAULIC HOSE (TEE - POTHOLE CYL)	3
13	505094-000	HYDRAULIC HOSE(BLOCK - STEER CYL, ANNULAR)		31	505097-000	HYDRAULIC HOSE (TEE - POTHOLE CYL)	1
14	N/A	N/A	N/A	32	503782-000	TEE PIECE (POTHOLE SYSTEM)	2
15	N/A	N/A	N/A	33	505036-000	HYDRAULIC CYLINDER (POTHOLE)	2
16	N/A	N/A	N/A	34	N/A	N/A	N/A
17	N/A	N/A	N/A	35	505013-000	TANK (HYDRAULIC RESERVOIR)	1
18	505104-000	HYDRAULIC HOSE (RETURN T - FILTER)	1	36	503782-000	TEE PIECE (CYL DRAIN)	1

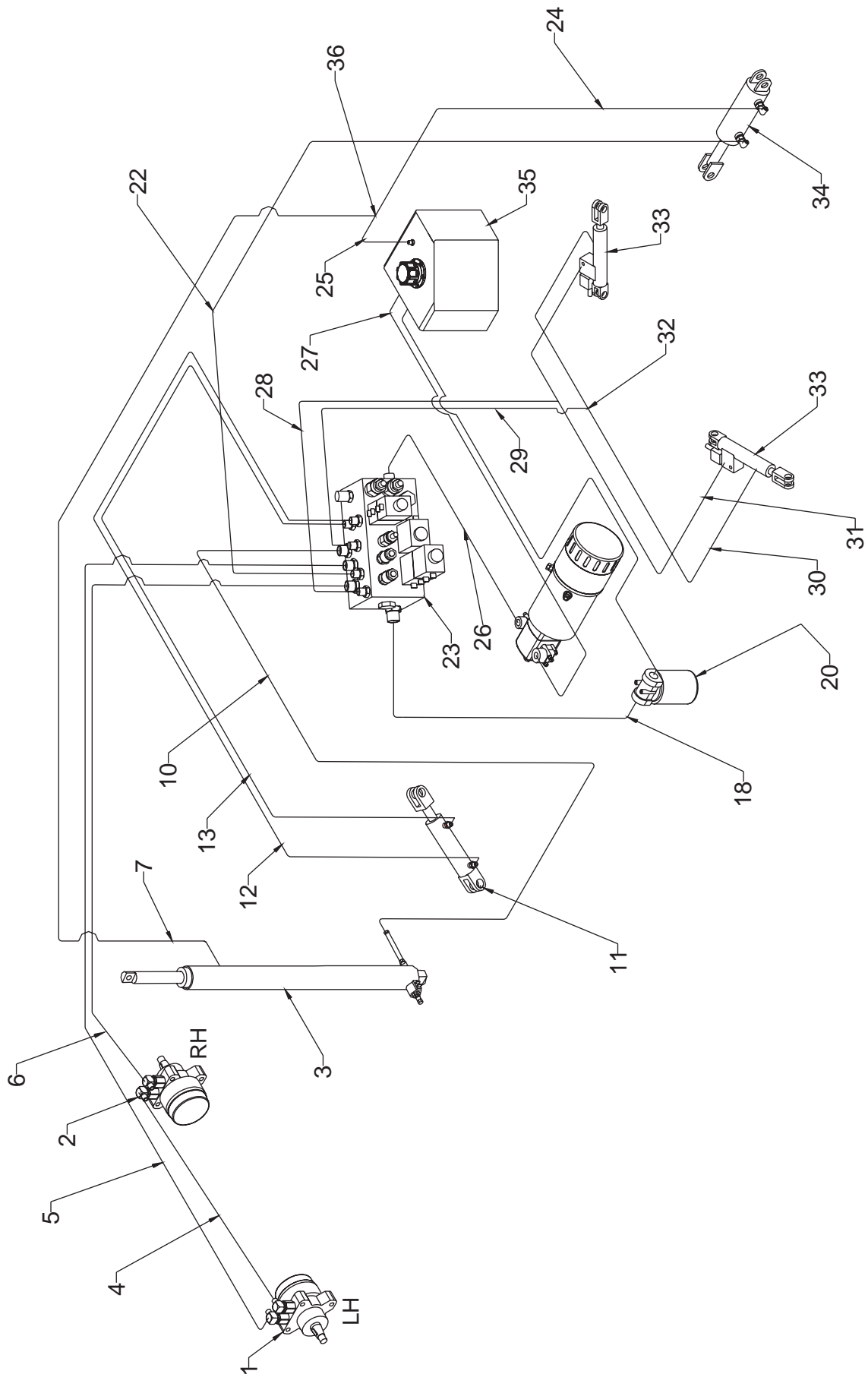

Control Valve Assembly

101120-021 | Serial # M30176-M30338 |

ITEM	PART NO.	DESCRIPTION	QTY
1	100020-040	CONTROL VALVE BLOCK	1
2	012004-002	FITTING #2 PLUG	9
3	012004-004	FITTING #4 PLUG	15
4	011941-005	FITTING STRAIGHT 6MB - 6MJ	3
5	011941-001	FITTING STR 4MBH - 4MJ	7
6	012004-006	FITTING PLUG #6	6
7	063955-008	PLUG CAVITY #8 2 WAY	1
8	011941-009	FITTING 8MB-6MJX	1
9	060390-013	RELIEF VALVE, STEERING (1500 PSI)	1
10	060390-025	RELIEF VALVE, MAIN (3000 PSI)	1
11	063923-006	2 POS - 4 WAY SOLENOID W/ COIL	1
12	101120-033	COIL	2

ITEM	PART NO.	DESCRIPTION	QTY
13	064845-000	3 POS - 4 WAY SOLENOID W/ COILS	1
14	101120-035	COUNTERBALANCE VALVE	2
15	011941-008	FITTING STR 8MB-4MJ	1
17	064843-000	FLOW DIVIDER VALVE (1.0 GPM)	1
18	063973-001	2 POS POPPET VALVE W/ COIL	1
19	101120-033	COIL	1
20	012004-008	FITTING #8 PLUG	1
21	063965-001	FITTING GAGE	1
22	064841-000	CHECK VALVE	1
23	063923-021	3 POS - 4 WAY SOLENOID W/ COILS	1
24	020021-004	FITTING, PLUG #4	1

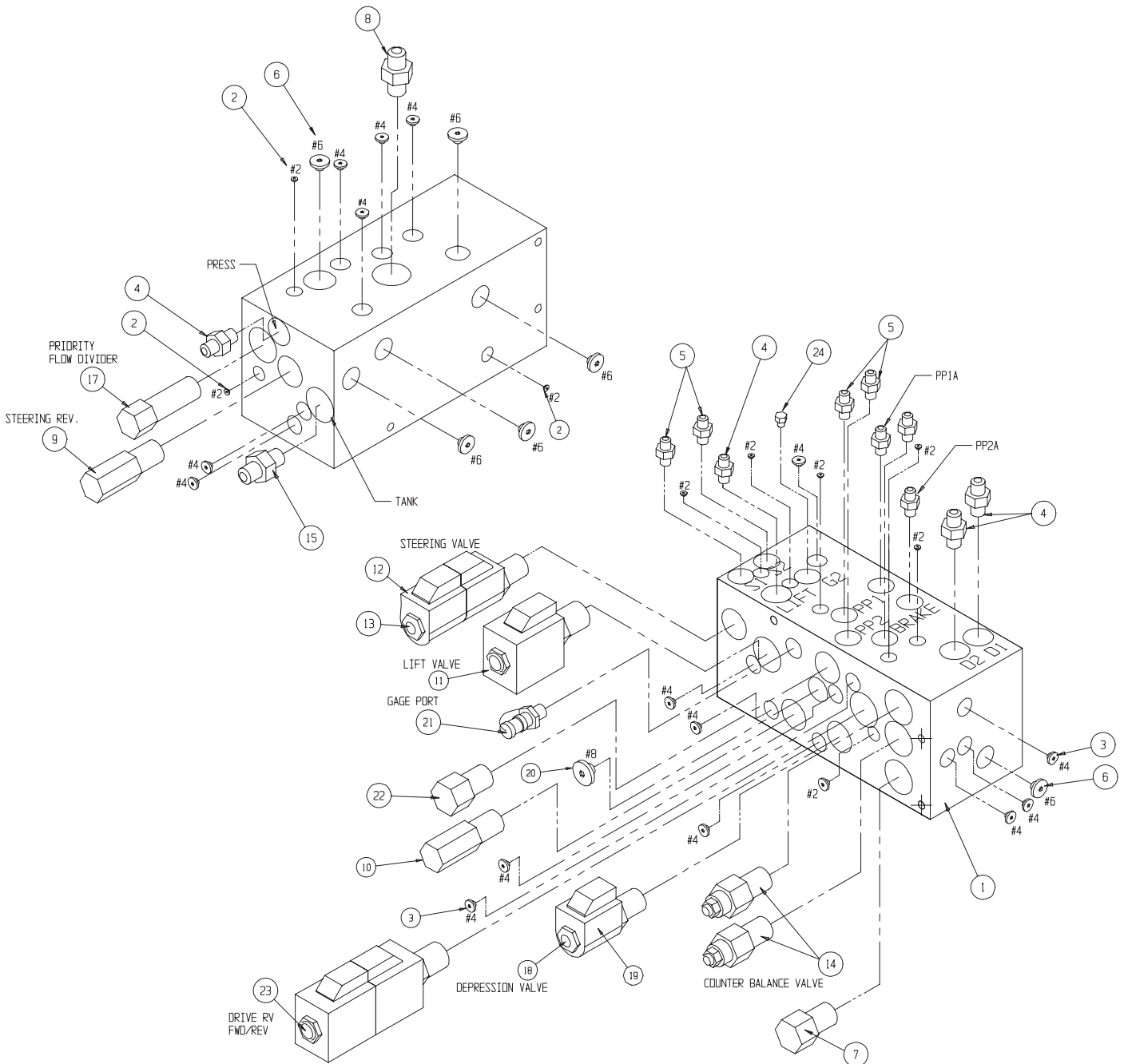

Control Valve Assembly

503800-000 | Serial # M30339-M30642 |

ITEM	PART NO.	DESCRIPTION	QTY
1		TEST PORT	1
2	058358-000	FITTING, 1/4" - 1/4" MALE/MALE	1
3	058358-000	FITTING, 1/4" - 1/4" MALE/MALE	1
4	058358-000	FITTING, 1/4" - 1/4" MALE/MALE	1
5	057122-000	FITTING, 3/8" - 3/8" MALE/MALE	1
6	057122-000	FITTING, 3/8" - 3/8" MALE/MALE	1
7	058590-000	FITTING, 1/4 M/M ADAPTOR WITH 1mm OROFICE	1
8	057122-000	FITTING, 3/8" - 3/8" MALE/MALE	1
9	057358-000	FITTING, 1/4" - 1/4" MALE/MALE	1
10	N/A	N/A	N/A
11	057377-000	FITTING, 1/2" - 1/2" (MALE/MALE)	1
12	503802-000	CHECK VALVE, POTHOLE	1
13	503803-000	CROSS LINE RELIEF VALVE (DRIVE)	1

ITEM	PART NO.	DESCRIPTION	QTY
14	503804-000	VALVE, SOLENOID (DRIVE)	1
15	503805-000	VALVE, SOLENOID (DRIVE/LIFT)	1
16	503803-000	CROSS LINE RELIEF VALVE (DRIVE)	1
17	503807-000	PRESSURE RELIEF (MAIN LIFT)	1
18	503808-000	VALVE, SOLENOID (STEERING)	1
19	503809-000	FLOW RESTRICTOR (STEERING)	1
20	058728-000	RELIEF VALVE (STEERING)	1
21	057122-000	FITTING, 3/8" - 3/8" MALE/MALE	1
22	503810-000	RELIEF VALVE (MAIN RELIEF)	1
23	500303-000	COIL 18V	6

NOTE:All fittings on valve block are BSP to JIC

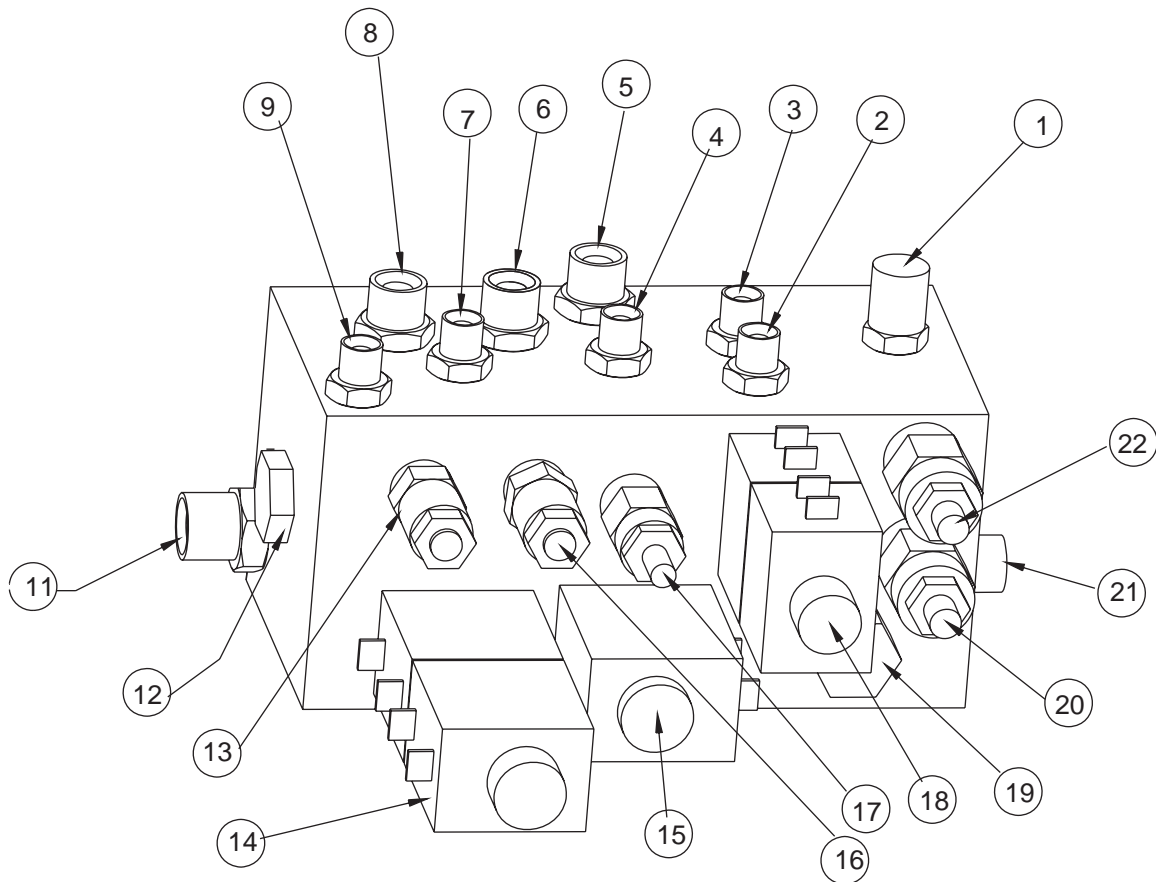

Controller Assembly

107010-000 | Serial # M30176-M30338 |

ITEM	PART NO.	DESCRIPTION	QTY
1	107157-000	CONTROL COVER	1
2	107159-000	CONTROLLER WELDMENT	1
3	066805-002	SWITCH, SELECTOR - 2 POSITION	1
-	068807-010	KEY (NOT SHOWN)	1
4	066805-012	CONTACT BLOCK, NO-NC	1
5	065512-000	CONTROLLER PQ	1

ITEM	PART NO.	DESCRIPTION	QTY
6	066805-011	CONTACT BLOCK	1
7	066805-006	PUSHBUTTON	1
8	063956-003	CONN 12 PIN MATE N LOC	1
9	064462-029	HOLE PLUG	1
14	011826-004	SCREW 10-32 SLFTP X 1/2	6
15	026525-008	SCREW #8 SLFTP ABHWH X 1	4

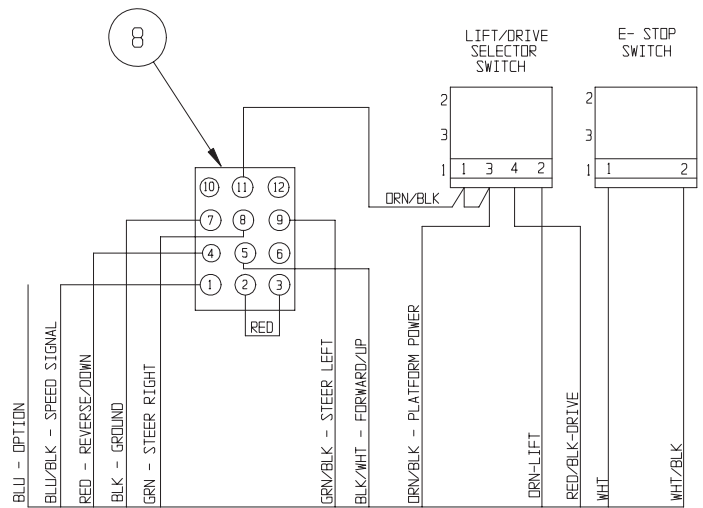
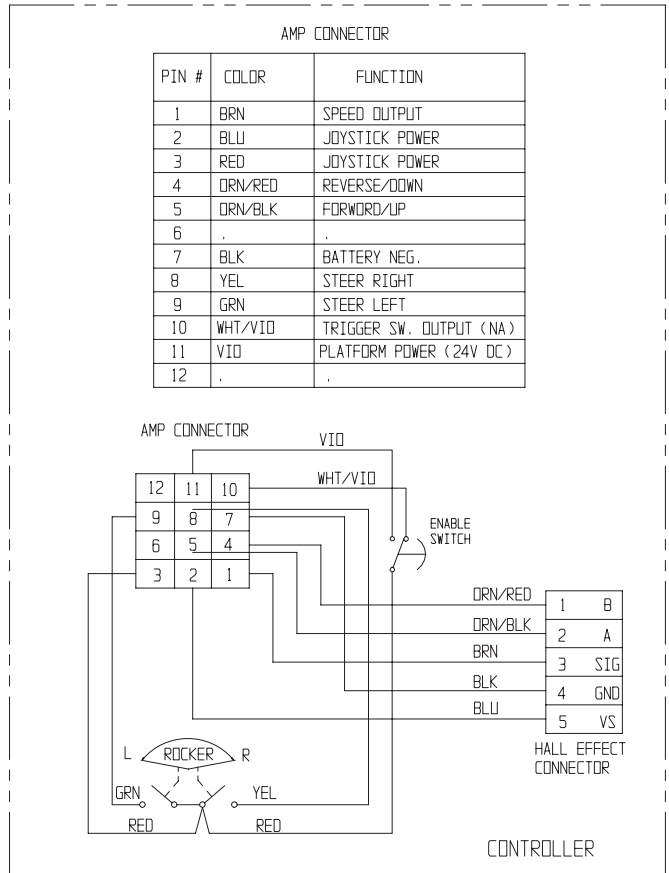
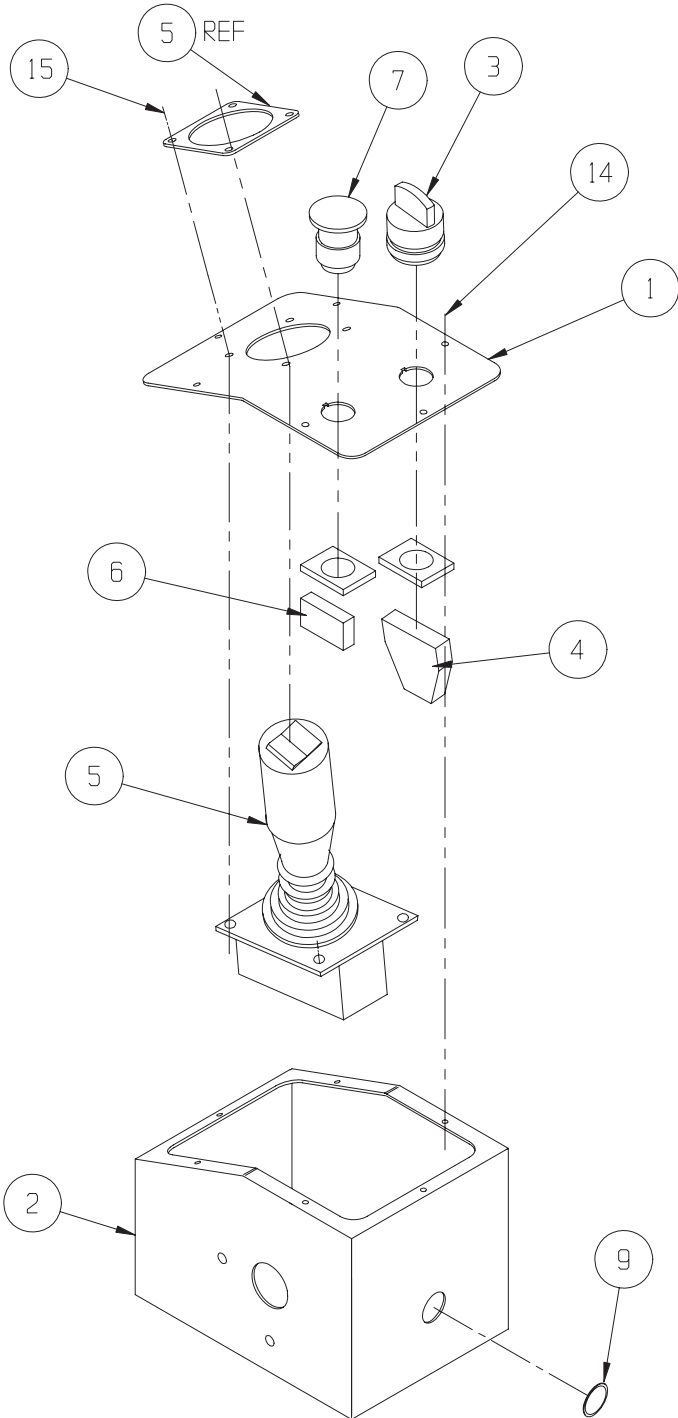

PQ Controller

065512-000 | Serial # M30176-M30338 |

ITEM	PART NO.	DESCRIPTION	QTY
1	063953-001	CAP, RUBBER	1
2	065512-013	ROCKER, PIN	1
3	063953-007	SWITCH, INTERLOCK	1
4	065512-015	SWITCH, STEERING	1
5	065512-016	HANDLE HALF, RIGHT	1
6	065512-017	HANDLE HALF, LEFT	1
7	065512-018	BOOT, HANDLE	1

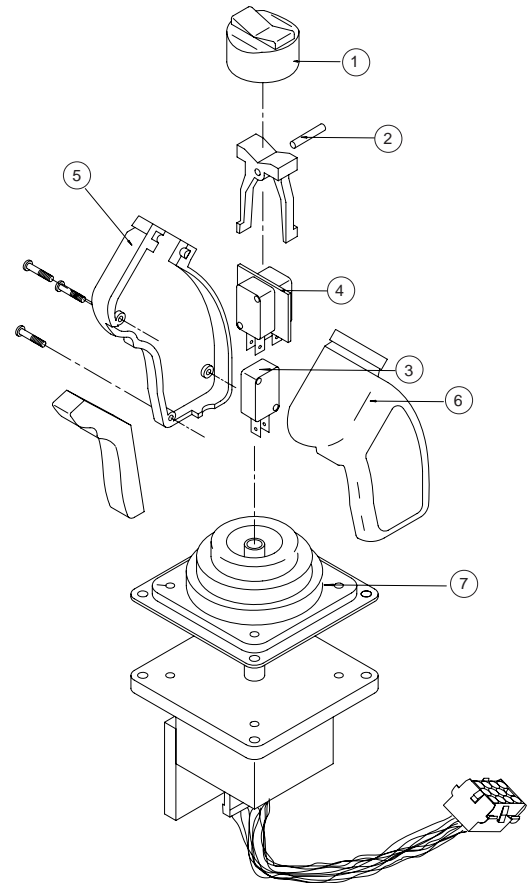

Electrical Box Assembly

107008-000 | Serial # M30176-M30338 |

ITEM	PART NO.	DESCRIPTION	QTY
1	107123-000	BOX, ELECT. WELDMT	1
2	107148-000	BOX TOP	1
3	066805-004	SWITCH KEY SELECTOR	1
4	068582-005	CIRCUIT BREAKER 5 AMP	1
5	012798-000	SWITCH TOGGLE	1
6	029925-001	CONNECTOR CABLE 3/4	1
7	011725-006	SCREW, 1/4-20 UNC PAN HD x3/4	1
8	066805-011	SWITCH CONTACT	1

ITEM	PART NO.	DESCRIPTION	QTY
9	011811-004	SCREW,10-32 SELF-TAP x 1/2	3
10	066805-006	SWITCH HEAD-MUSHROOM	1
11	066807-001	ALARM, DUAL TONE	1
12	015752-000	HOUR METER	1
13	029872-000	BOOT SWITCH COVER	1
14	066805-010	CONTACT BLOCK	2
15	029939-003	LOCKNUT, CONDUIT 3/4	1

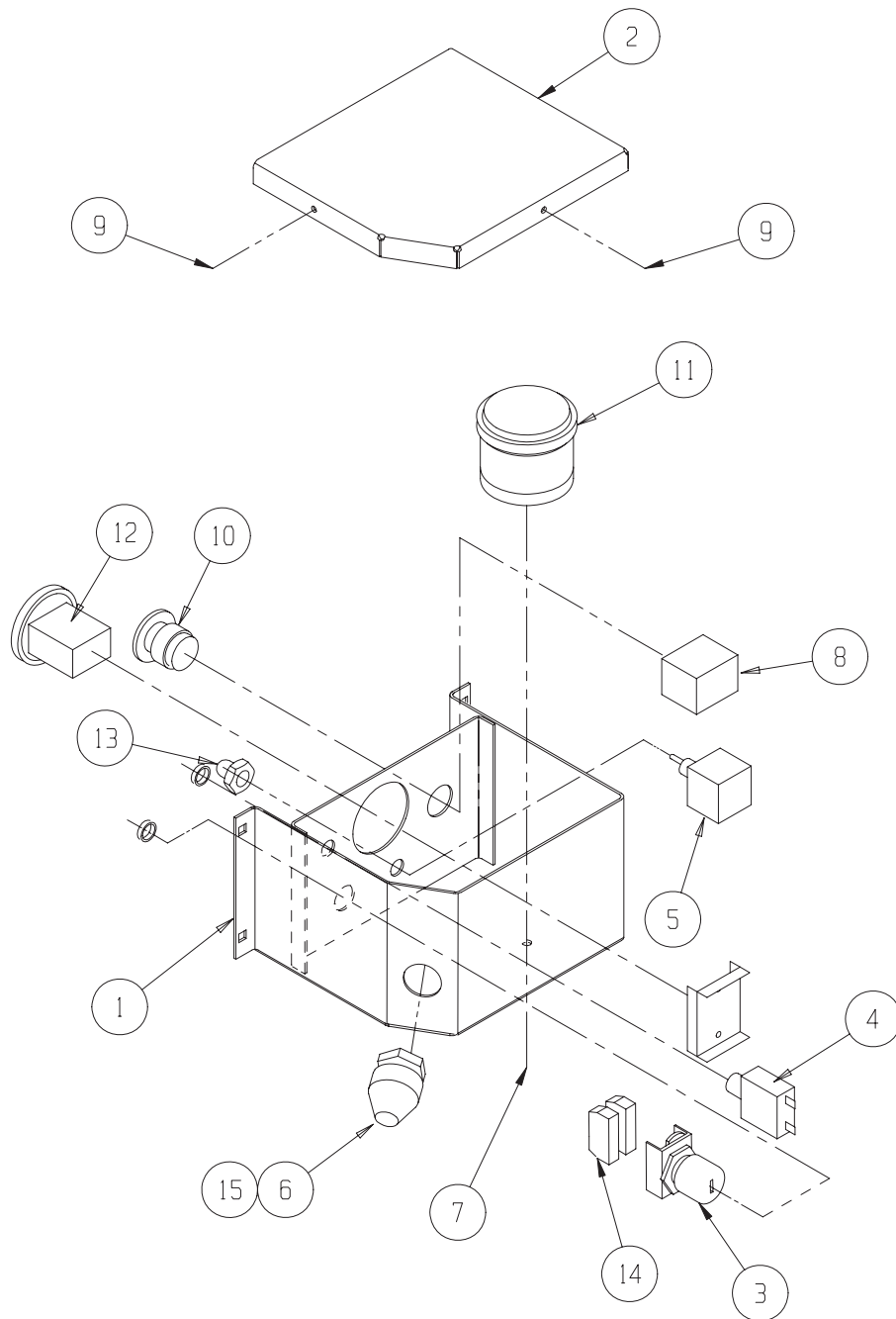

Level Sensor Wire Assembly 029945-020

ITEM	PART NO.	DESCRIPTION	QTY
1	029945-011	LEVEL SENSOR PQ #40000-00006	1
2	067456-000	PLUG 3 CONTACT DT 06-3S	1
3	067456-002	WEDGE W3S-PO12	1
4	068762-001	CONTACT SOCKET	3
5	067456-005	BOOT DT3S-BT	1

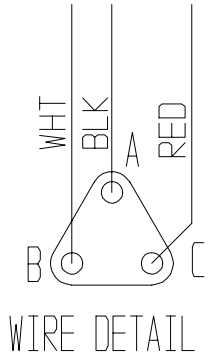
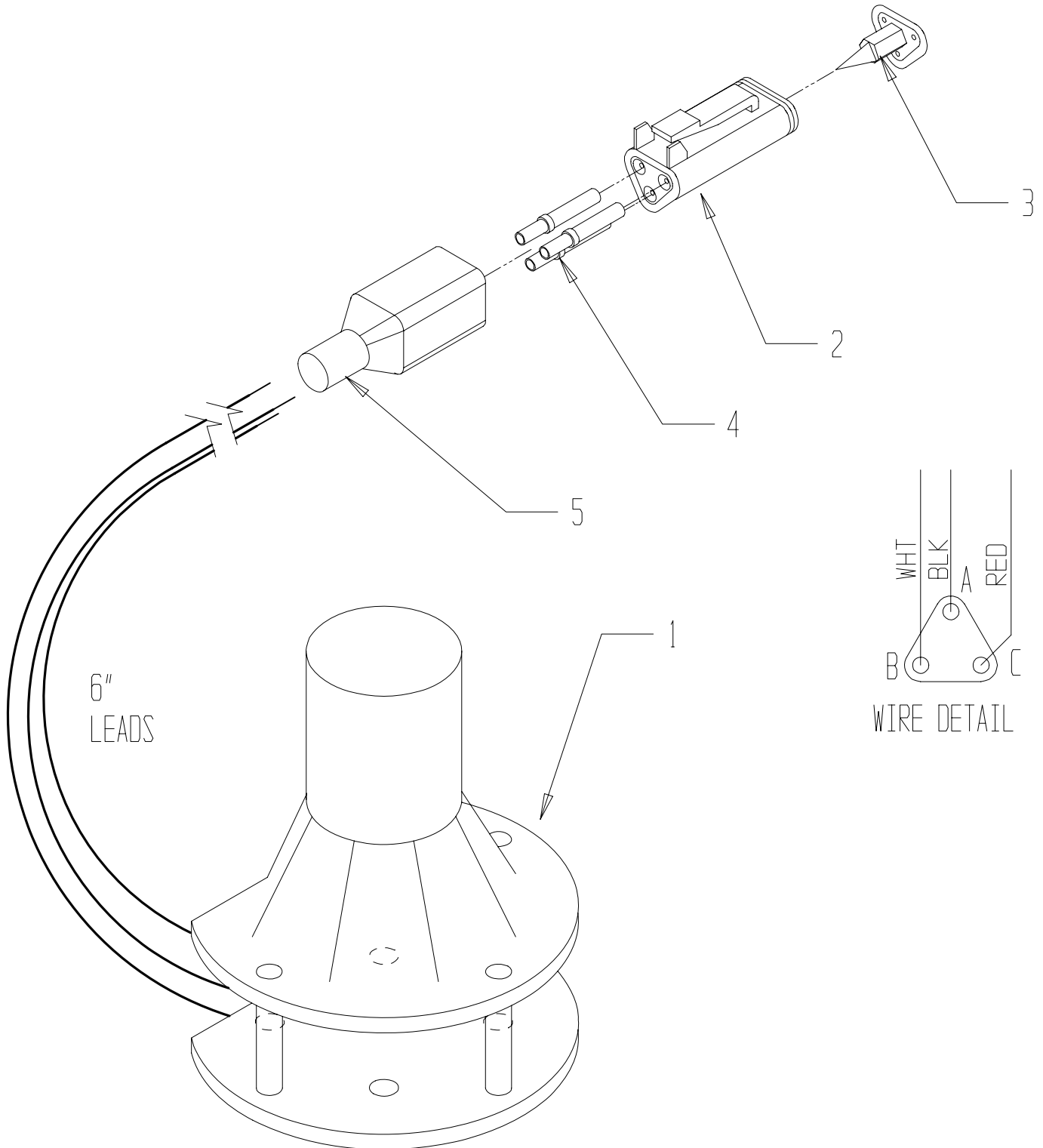

Control Cable

107009-000 | Serial # M30176-M30338 |

ITEM	PART NO.	DESCRIPTION	QTY
1	065394-002	CORD RETRACT 18 AWG 12 COND	1
2	029601-006	CONN RING 22-18 GA. 1/4 DIA.	1
3	068764-000	SEAL PLUG, DEUTSCH#114017	2
4	063956-010	CONN PIN MALE MATE N LOCK	9
5	068908-000	PLUG BOOT 12 PIN, DEUTSCH#DT12S-BT	1
6	068762-003	SOCKET CONTACT, DEUTSCH#0462-201-16141	10

ITEM	PART NO.	DESCRIPTION	QTY
7	068760-000	PLUG 12 SOCKET, DEUTSCH #DT06-12SA	1
8	068761-001	LOCKING WEDGE 12 PIN, DEUTSCH #W12S	1
9	029454-099	WIRE 16 AWG RED	3 IN
10	029610-006	CONN FORK 16-14 GA #6	2
11	029610-001	CONN FORK 22-18 GA #6	4
12	029477-099	WIRE 16 AWG ORN/BLK	12 IN

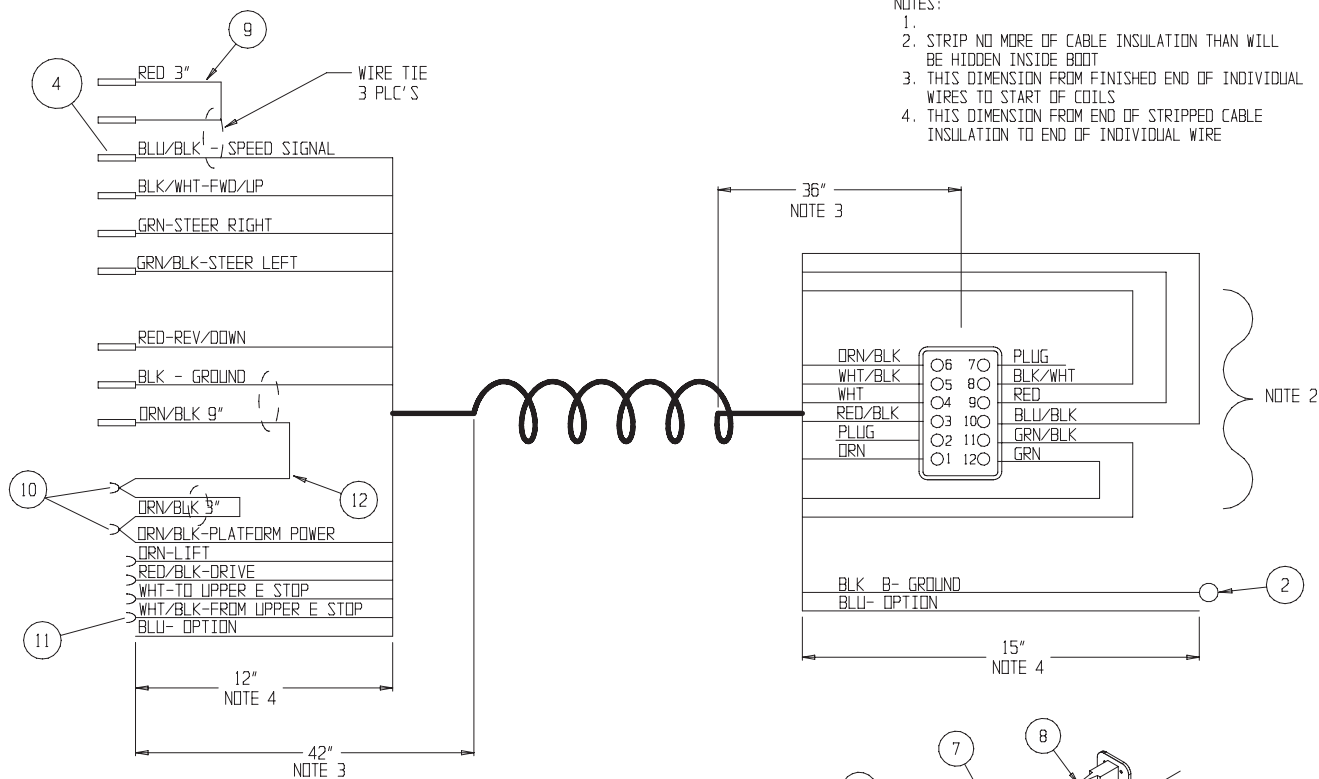

NOTES:

1. STRIP NO MORE OF CABLE INSULATION THAN WILL BE HIDDEN INSIDE BOOT
2. THIS DIMENSION FROM FINISHED END OF INDIVIDUAL WIRES TO START OF COILS
3. THIS DIMENSION FROM END OF STRIPPED CABLE INSULATION TO END OF INDIVIDUAL WIRE

12 PIN PLUG ASSEMBLY SHOWN
NOTE: USE DEUTSCH #HDT-48-00 HAND CRIMPER FOR WIRE TO PIN/SOCKET. USE #DT-RT1 TOOL TO REMOVE WEDGES IN PLUG & RECEPTACLE.

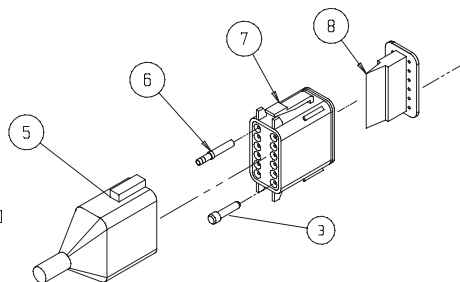

Lower Control Cable

107193-000 | Serial # M30176-M30338 |

ITEM	PART NO.	DESCRIPTION	QTY
1	029601-011	CONN RING 16-14 GA. #6 DIA.	5
2	029601-014	CONN RING 16-14 GA. 1/4 DIA.	2
3	029610-003	CONN FORK 10-12 GA #6	2
4	029610-006	CONN FORK 16-14 GA #6	5
5	029931-004	CONN FM PUSH 3/16 X .032" 16-14 GA	2
7	012865-099	LOOM 3/4	4
8	068762-001	SOCKET CONTACT. DEUTSCH #0460-209-16141	11
9	068760-010	PLUG 12 SOCKET, DEUTSCH #DT06-12SC	1
10	068761-001	LOCKING WEDGE 12 PIN, DEUTSCH#W12S	1
11	068908-000	CONNECTOR BOOT, DEUTSCH #DT12S-BT	1
12	029931-003	CONN FM PUSH 16-14 1/4	2
13	029452-099	WIRE 16 AWG BLK	9 FT
14	029353-099	WIRE 16 AWG GRN/WHT	4 FT
15	029355-099	WIRE 16 AWG BLK/RED	8 FT
16	029457-099	WIRE 16 AWG GRN	6 FT
17	029453-099	WIRE 16 AWG ORN	4 FT

ITEM	PART NO.	DESCRIPTION	QTY
18	029450-099	WIRE 16 AWG BLU	4 FT
19	029475-099	WIRE 16 AWG BLU/BLK	4 FT
20	029478-099	WIRE 16 AWG RED/BLK	4 FT
21	005491-099	WIRE 16 AWG GRN/BLK	4 FT
23	029358-099	WIRE 16 AWG BLU/RED	1 FT
24	029354-099	WIRE 16 AWG BLU/WHT	5 FT
25	029356-099	WIRE 16 AWG WHT/RED	5 FT
26	029601-019	CONN RING 10-12 GA #10	2
27	029931-005	CONN FM PUSH 1/4 10-12 GA	4
28	0.	LOOM, 3/8	1.5 FT
29	029418-099	WIRE, 12 AWG RED/BLK	1 FT
30	029601-039	CONN RING 10-12 GA - 5/16	2
31	029479-099	WIRE, 16 AWG WHT/BLK	4 FT
32	029617-002	CONN M PUSH 1/4 16-14	1
33	029925-001	CONNECTOR, CABLE 3/4, T&B #2675	1

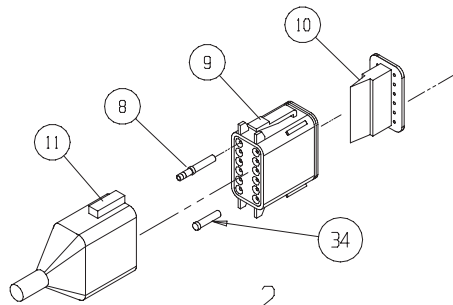

12 PIN PLUG ASSEMBLY SHOWN

NOTE: USE DEUTSCH #HDT-48-00 HAND CRIMPER FOR WIRE TO PIN/SOCKET. USE #DT-RT1 TOOL TO REMOVE WEDGES IN PLUG & RECEPTACLE.

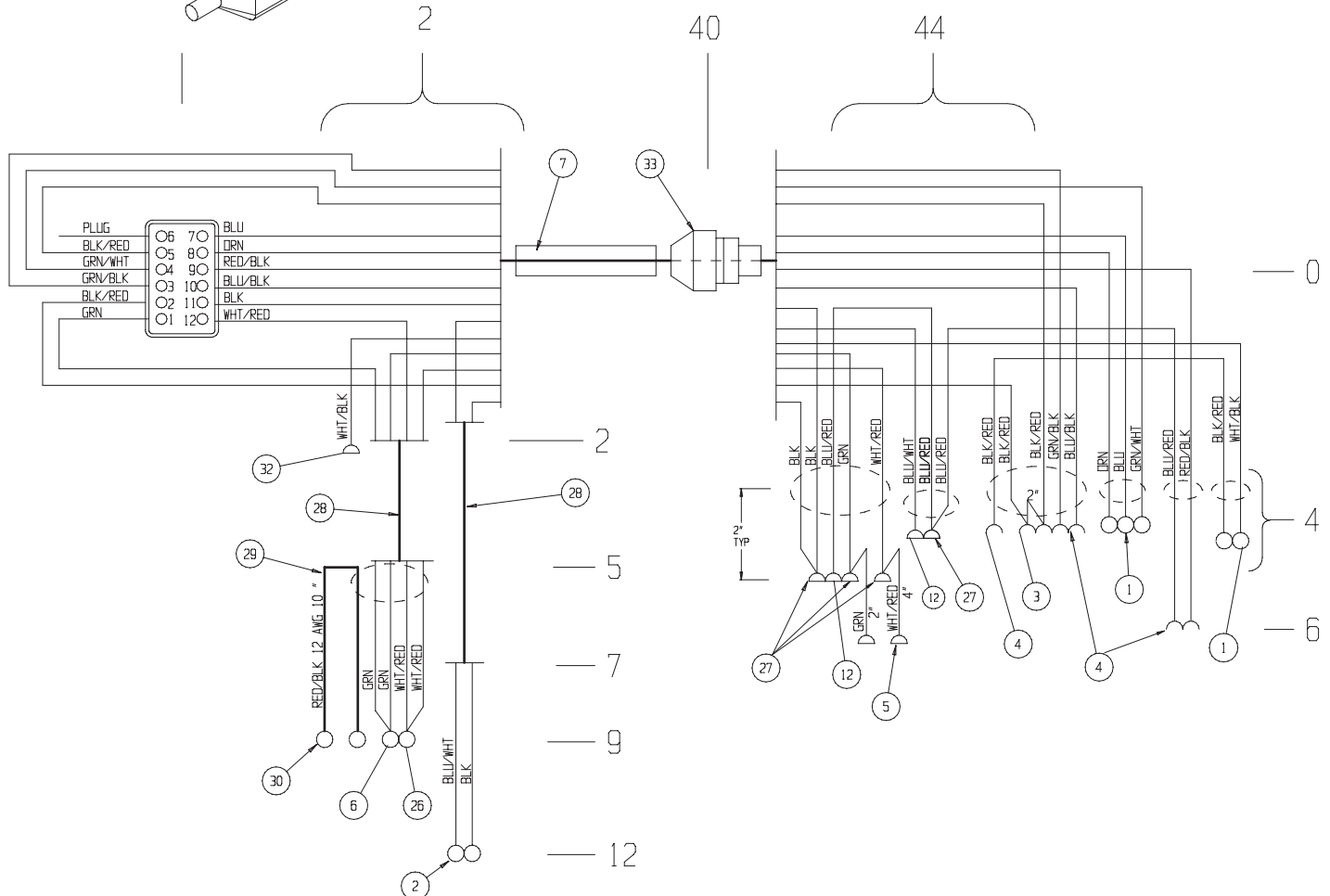

Chassis Control Cable

107194-001 | Serial # M30176-M30338 |

ITEM	PART NO.	DESCRIPTION	QTY	ITEM	PART NO.	DESCRIPTION	QTY
1	068760-018	PLUG 8 SOCKET, DEUTSCH#DT06-8SC	1	12	029451-099	WIRE 16 AWG WHT	2.5 FT
2	068762-001	CONTACT SOCKET, DEUTSCH#0460-209-16141	7	13	029351-099	WIRE 16 AWG BLK/WHT	4 FT
3	068764-000	PLUG SEAL, DEUTSCH#114017	1	14	029359-099	WIRE 16 AWG RED/GRN	3 FT
4	068761-009	LOCKING WEDGE, DEUTSCH#W8S	1	15	029352-099	WIRE 16 AWG RED/WHT	2.5 FT
5	068908-002	BOOT DT, DEUTSCH#DT8S-BT	1	16	0.	LOOM 3/8	5.5 FT
6	029931-003	CONN FM PUSH 1/4 14-16	5	17	068642-099	LOOM 1/2	.5 FT
8	029620-002	CONN BUTT 14-16	4	18	067456-001	RECEPTACLE 3 PIN DT04-3P-E004	2
9	029479-099	WIRE 16 AWG WHT/BLK	.25 FT	19	067456-003	WEDGE LOCKING W3P-P012	2
10	029452-099	WIRE 16 AWG BLK	2.5 FT	20	068762-000	PIN CONTACT 0460-215-16141	6
11	029454-099	WIRE 16 AWG RED	8 FT	21	068908-005	BOOT 3 PIN DT 3P-BT	2

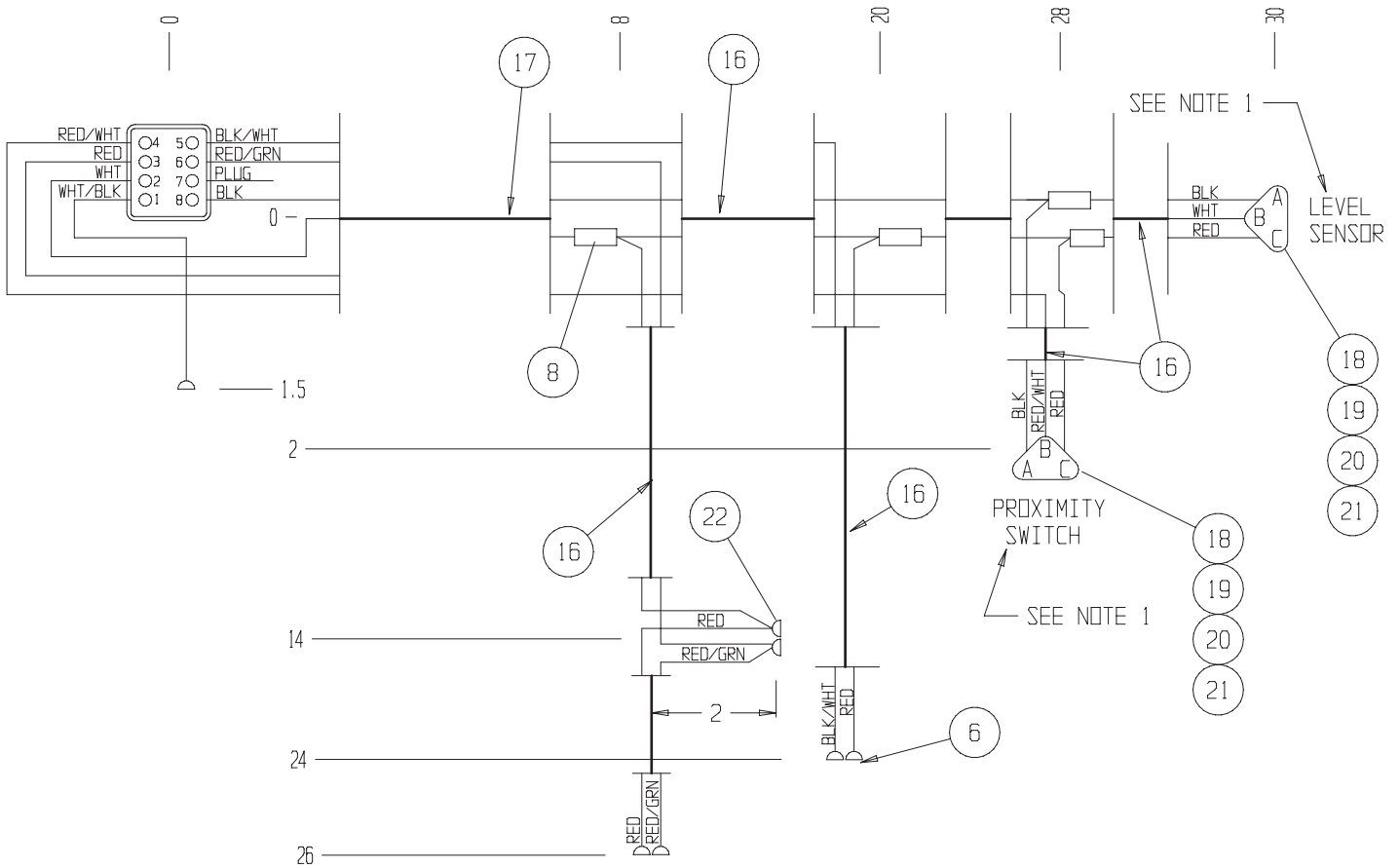
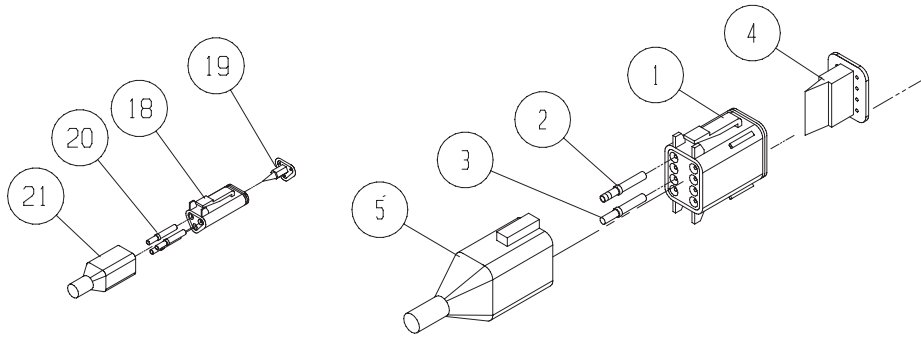

NOTE: 1. LABEL HARNESS NEAR CONNECTOR

Capacitor Harness

107054-001 | Serial # M30176-M30338 |

ITEM	PART NO.	DESCRIPTION	QTY
1	101245-001	CAPACITOR (KEMET P/N C340C225M5U5CA)	1
3	029620-002	CONN BUTT 16-14 GA INSL	2
4	029610-006	CONN FORK TERM 16-14 GA #6 LOCK	2
5	029454-099	WIRE, 16 AWG RED	1 FT
6	029351-099	WIRE, 16 AWG BLK/WHT	1.5
7	063956-002	PIN, CONTACT (AMP #350547-1)	2

ITEM	PART NO.	DESCRIPTION	QTY
8	063956-012	SOCKET, CONTACT (AMP #350550-1)	2
9	0.	CAP HOUSING (AMP #1-480699-0)	1
10	0.	PLUG HOUSING (AMP #1-480698-0)	1
11	0.	HEAT SHRINK, 1/8"	1 IN
12	0.	HEAT SHRINK, 3/8"	1.5 IN

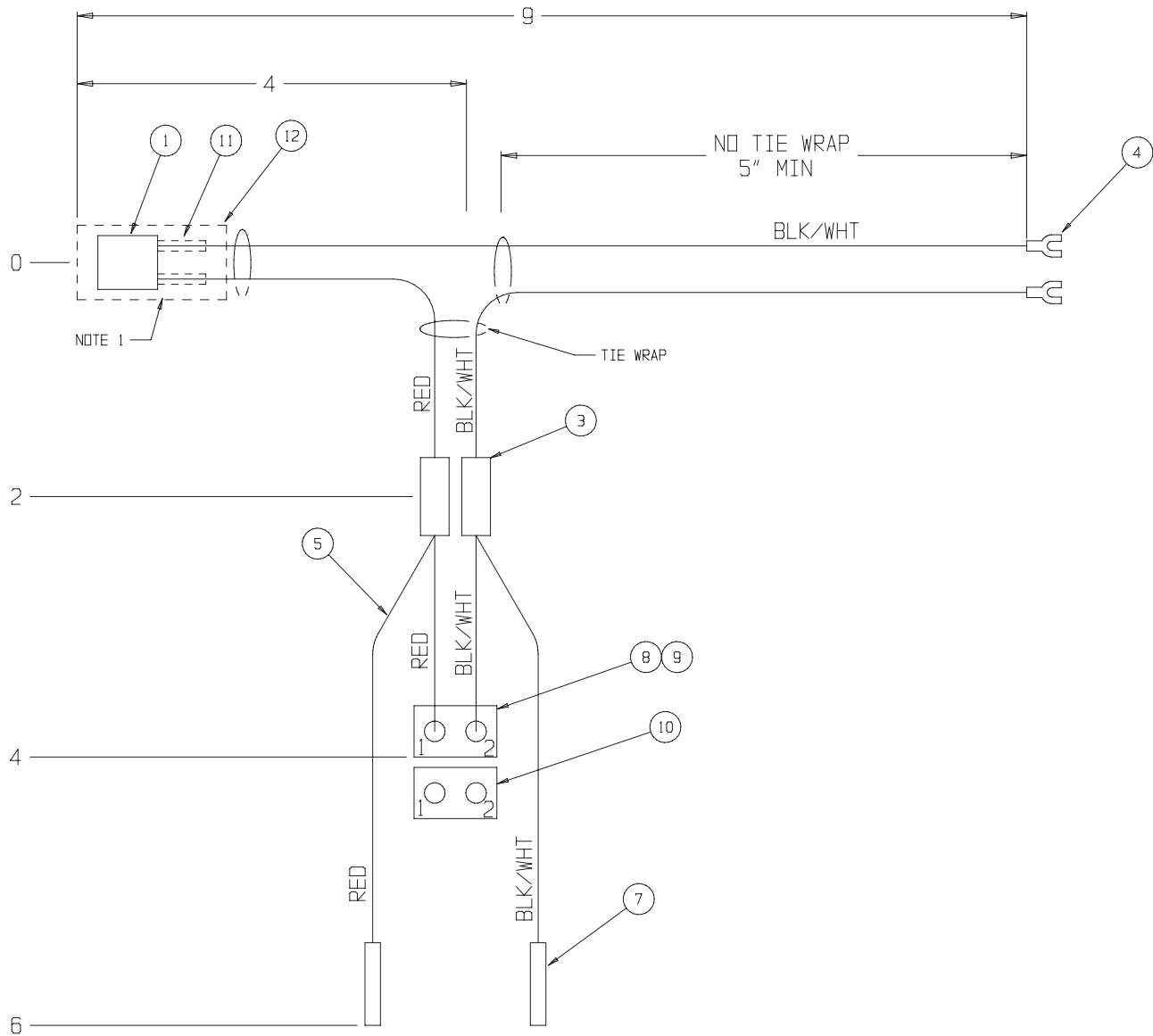

Valve Block Cable

107192-000 | Serial # M30176-M30338 |

1	068760-008	8 SOCKET PLUG, DEUTSCH#DT06-8SA	1
2	068762-001	CONTACT SOCKET, DEUTSCH#0460-209-16141	7
3	068764-000	SEAL PLUG, DEUTSCH#114017	1
4	068761-009	LOCKING WEDGE, DEUTSCH#W8S	1
5	068908-002	BOOT DT, DEUTSCH#DT8S-BT	1
6	029931-003	CONN FM PUSH 1/4 14-16	7
7	029479-099	WIRE 16 AWG WHT/BLK	2 FT
8	029452-099	WIRE 16 AWG BLU/BLK	1.5 FT

9	029450-099	WIRE 16 AWG BLU	1.5 FT
10	029457-099	WIRE 16 AWG GRN	1.5 FT
11	029453-099	WIRE 16 AWG ORG	1 FT
12	029451-099	WIRE 16 AWG WHT	1.5 FT
13	029454-099	WIRE 16 AWG RED	5 FT
14	029931-005	CONN FM PUSH 1/4 10-12 GA	5
15	0.	LOOM 3/8	1.5 FT

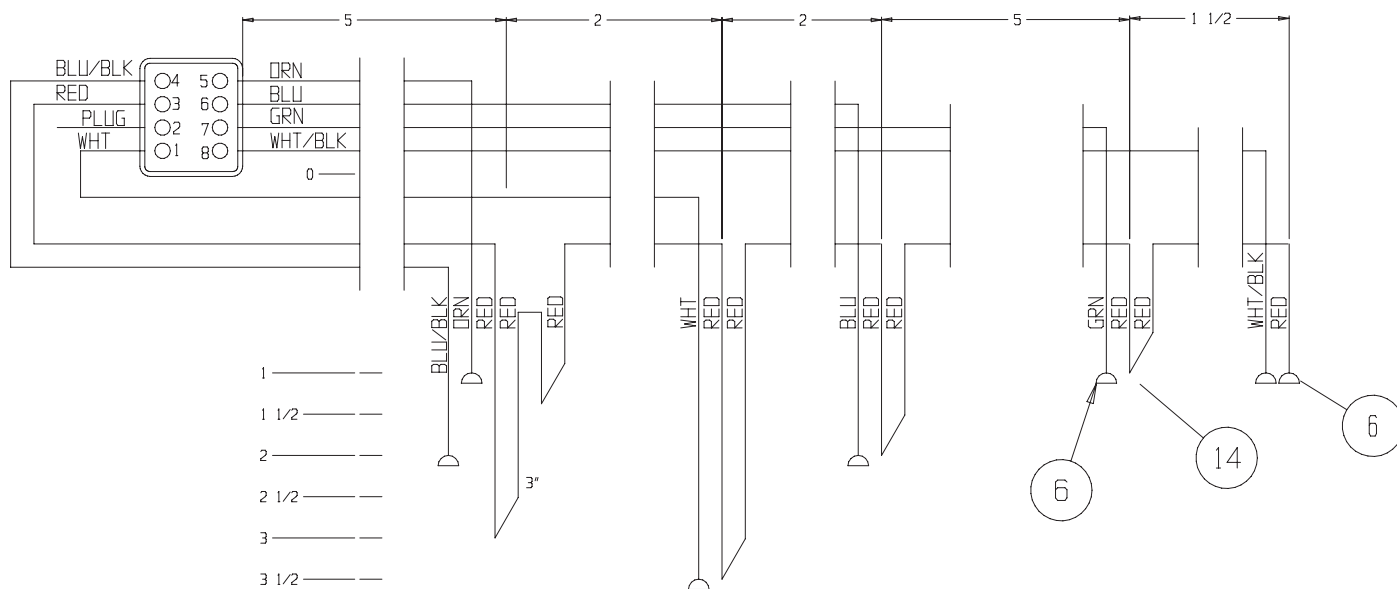
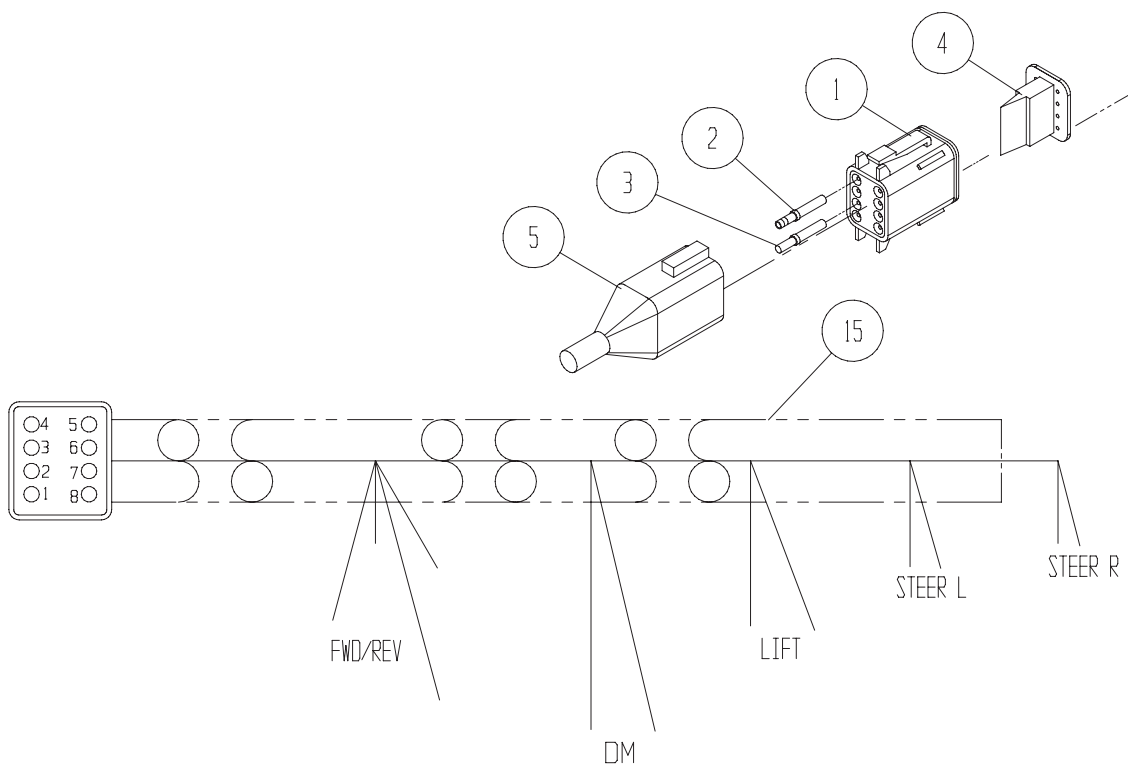

Lift Cylinder 107060-001

Item	Part	Description	QTY.
1		LIFT CYLINDER SEAL KIT	1
2		STANDPIPE ADAPTOR	1
3		EMERGENCY DOWN VALVE	1
4		ADAPTOR (EMERGENCY DOWN VALVE)	1

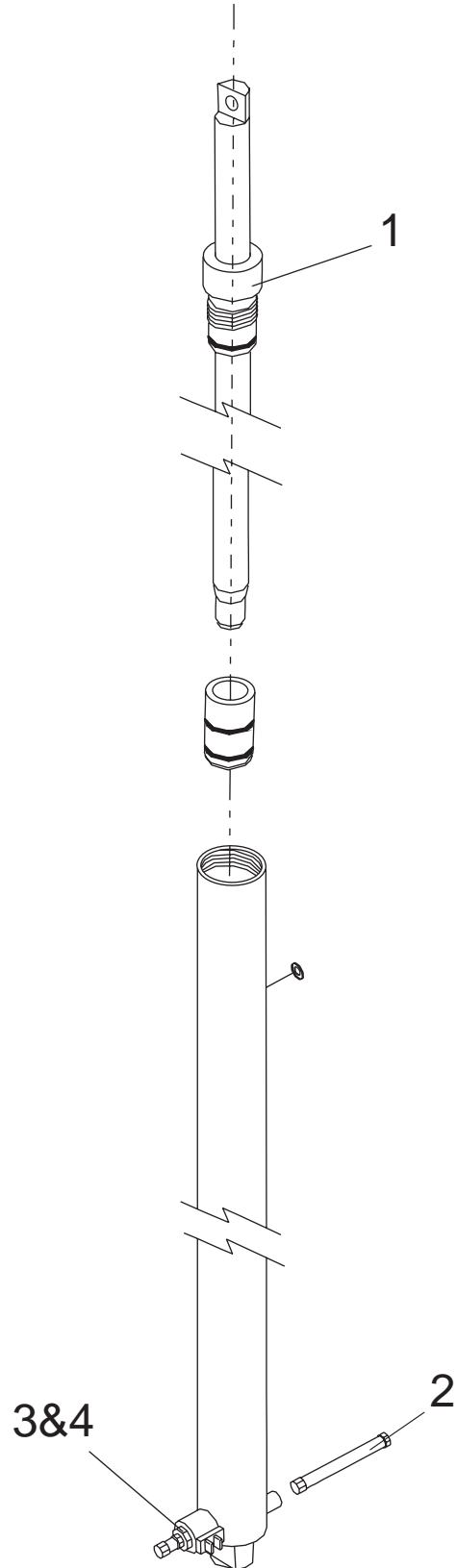

Brake\Steer Cylinder

065397-003

Item	Part	Description	QTY.
1		SEAL KIT, BRAKE/STEER CYLINDER	1
2		FITTING, 1/8 - 1/8 (M/M)	2
3		FITTING, 1/8 M/F BLOCK 90	1

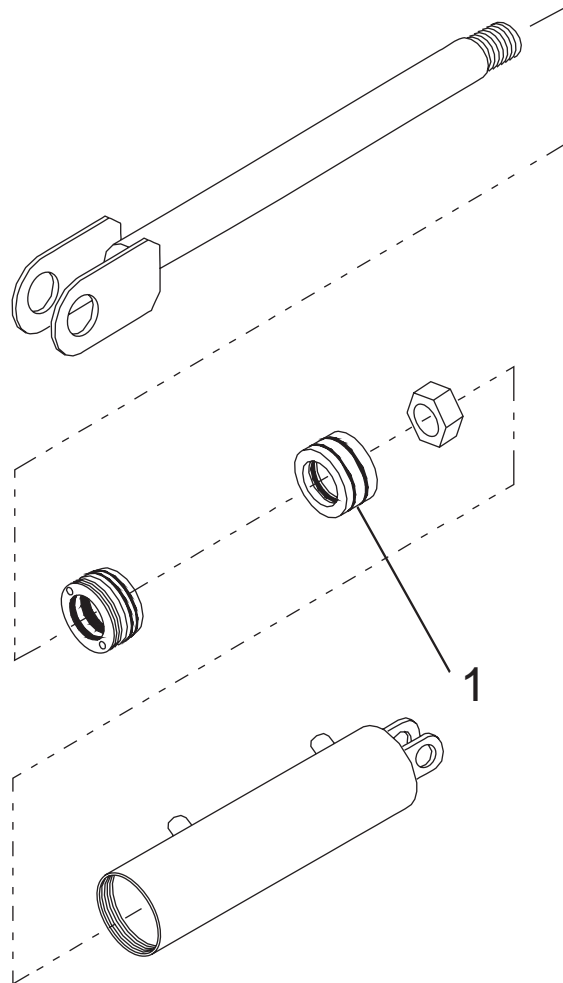
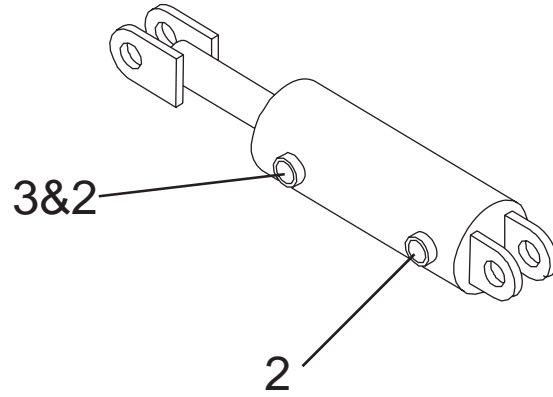

Depression Cylinder 113053-000

Item	Part	Description	QTY.
1		SEAL KIT, POTHOLE CYLINDER	1
2		EMERGENCY RELEASE VALVE	1
*		HANDLE (T-PIECE) EMERGENCY REL VALVE	1
3		BUSHING	2
4		FITTING, 1/4 - 1/8 (M/M)	1
5		FITTING, 1/8 - 1/8 (M/M)	1

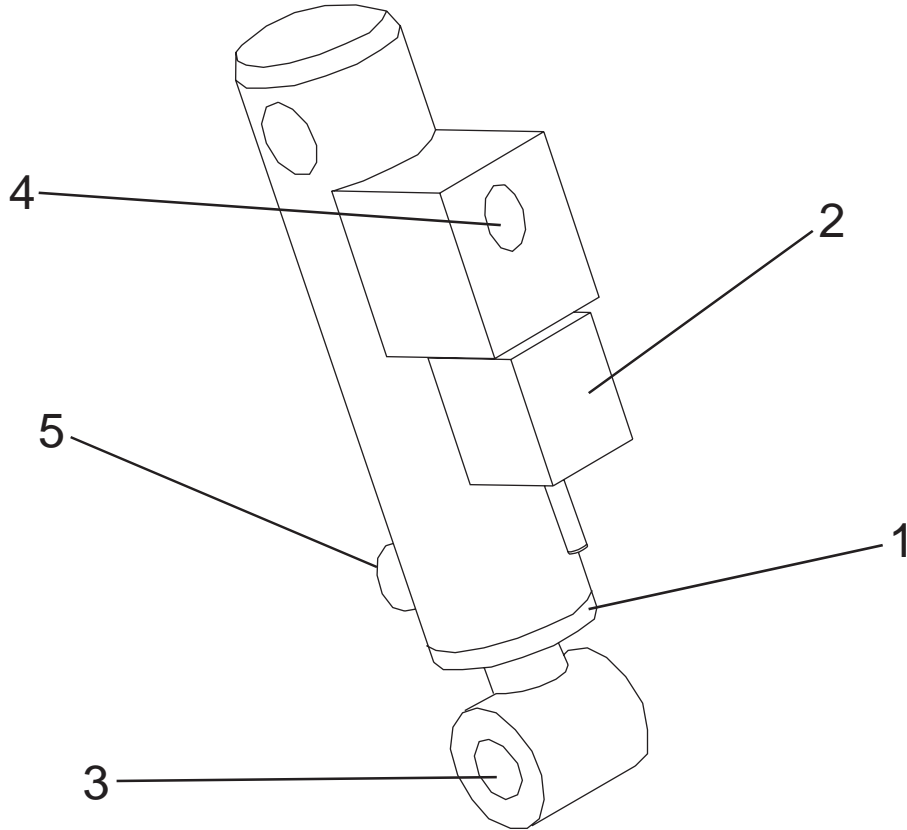

Drive Relief Valve Assembly

107006-000 | Serial # M30176-M30338 |

ITEM	PART NO.	DESCRIPTION	QTY
1	107006-001	VALVE BLOCK	1
2	107006-002	VALVE, DRIVE RELIEF	1
3	011934-004	FITTING, 90°, 6MB - 6MJ	1
4	011935-003	FITTING, 45°, 6MB - 6MJ	1

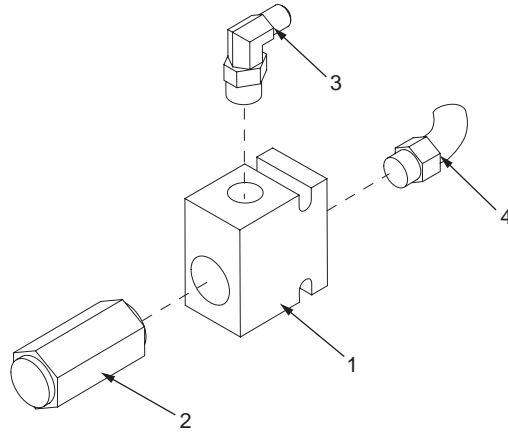

TORQUE DRIVE RELIEF VALVE TO 35 - 40 FT. LBS (47 - 54 Nm)

Flow Control Valve

107061-000 | Serial # M30176-M30338 |

ITEM	PART NO.	DESCRIPTION	QTY
1	063924-008	VALVE, FLOW CONTROL 1.5GMP	1
2	107062-000	VALVE BODY	1
3	011941-005	FITTING, 6MB-6MJ	1
4	011934-003	FITTING, 6MB-4MJ X 90°	1
5	011934-004	FITTING, 6MB-6MJ X 90°	2

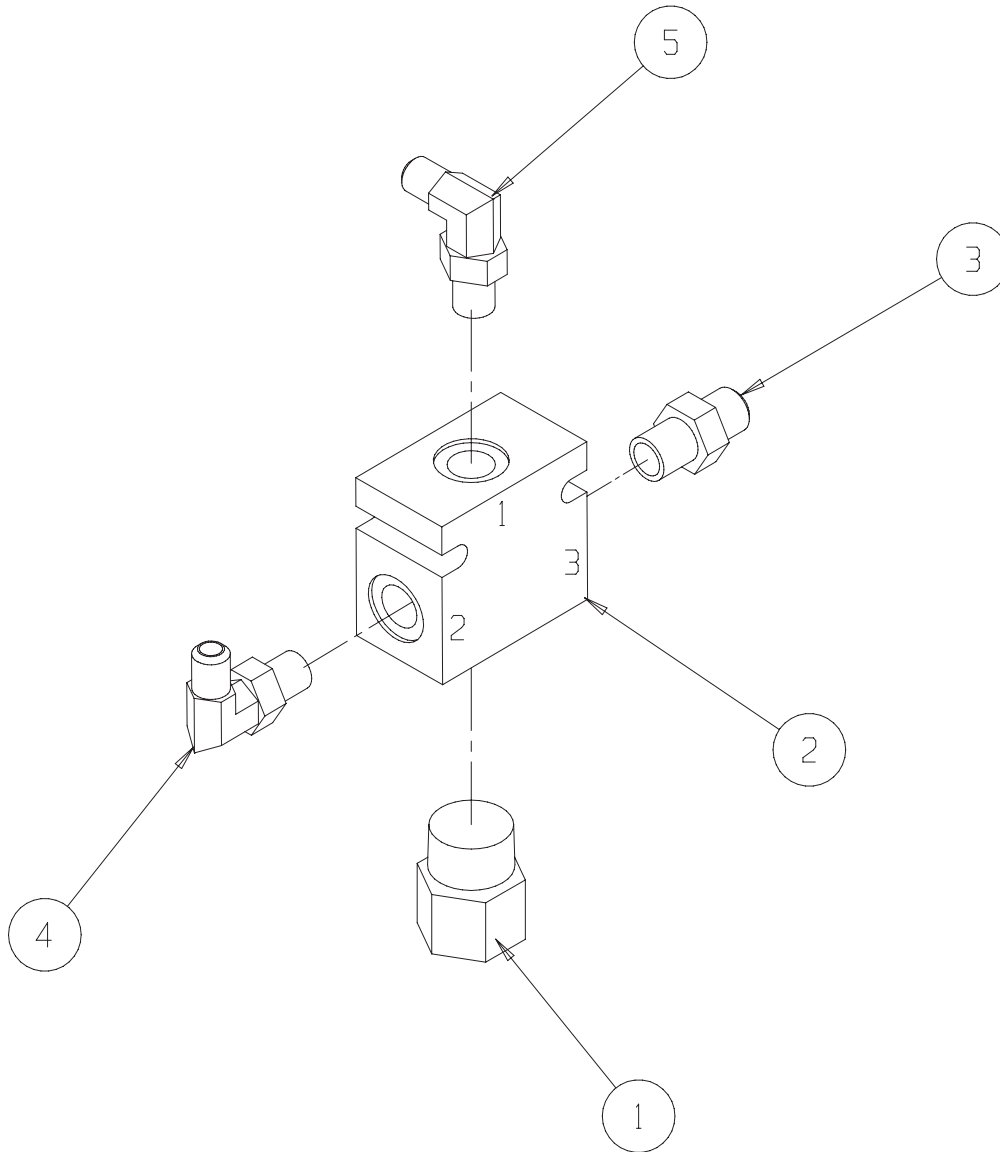

NOTE: UNLESS OTHERWISE NOTED, TORQUE FITTINGS TO UR #106

Hydraulic Tank Assembly 107066-000

ITEM	PART NO.	DESCRIPTION	QTY
1	107065-000	HYDRAULIC TANK - ROTAMOLDING	1
2	114067-000	RETURN FILTER - TANK IMMersed	1
3	114068-000	SUCTION STRAINER - 3/4 HOSE BARB	1
4	068982-001	CAP - HYDRAULIC OIL	1
5	107084-000	FITTING 90 BARB - 1/4 NPT	1

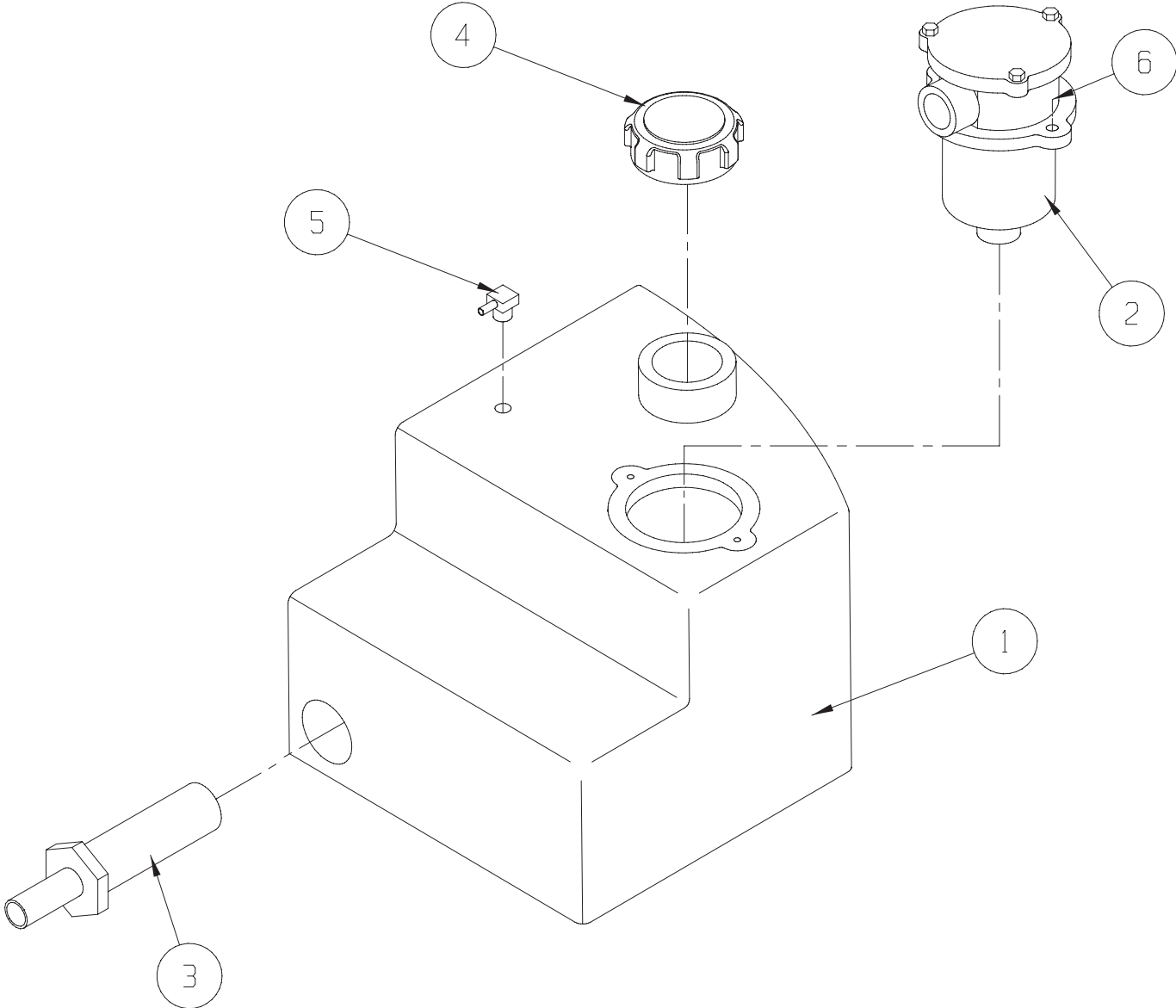

Label Kit

107012-010 | Serial # M30176-M30338 |

ITEM	PART NO.	DESCRIPTION	QTY
1	060197-000	LABEL HYD OIL	1
2	066552-000	LABEL HYDROGEN GAS	1
3	061205-005	NAME PLATE	1
5	005221-000	LABEL BATTERY FLUID	1
6	005223-005	LABEL EMERGENCY DOWN	1
7	066554-000	LABEL BEFORE OPERATING	1
8	107050-000	LABEL CONTROLLER	1
9	061683-003	LABEL UPRIGHT	2
10	101250-000	LABEL MAX LOAD 500 LBS.	3
11	061684-014	LABEL TM12	2
13	010076-001	LABEL ATTENTION	1
15	065568-001	LABEL CONTROLS	1

ITEM	PART NO.	DESCRIPTION	QTY
17	065368-000	TACK	4
19	062562-001	LABEL BATTERIES	1
20	066550-001	LABEL DANGER	1
21	14222-003-99	LABEL FORK LIFT	2
22	061220-002	ANSI	1
23	066555-000	LABEL RELIEF VALVE	1
24	066568-000	LABEL LOWER PLATFORM	1
25	066556-000	LABEL COLLISION HAZARD	3
26	066522-000	LABEL BATTERY CHARGER	1
27	101252-000	LABEL MAX WHEEL LOAD (675 LBS)	1
28	066556-001	LABEL WARNING	2
29	107051-000	LABEL, BATTERY DISCONNECT	1

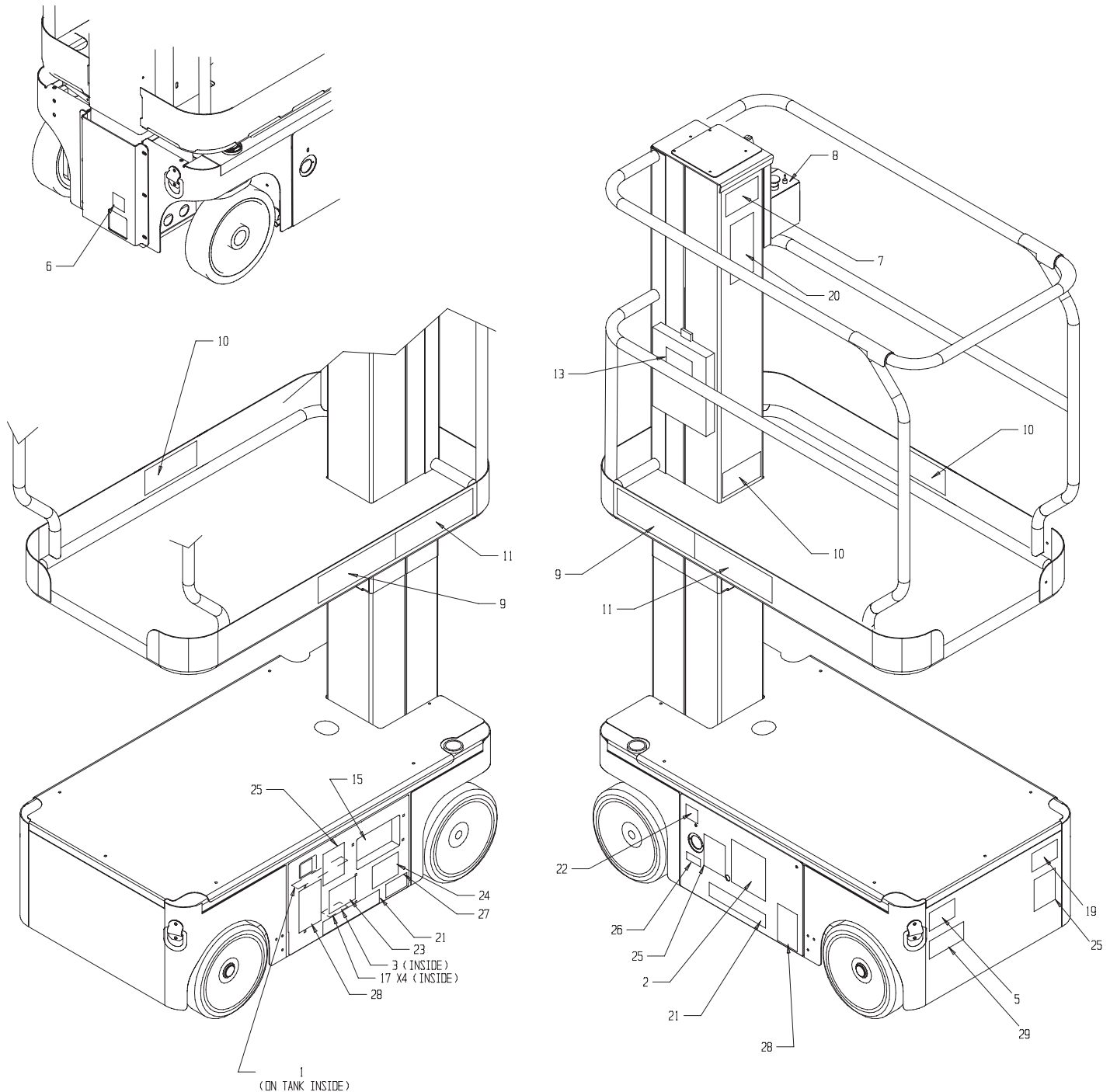

Voltage/Hourmeter Option

107032-000 | Serial # M30176-M30338 |

ITEM	PART NO.	DESCRIPTION	QTY
1	107008-000	ELECTRICAL BOX ASSY	REF
2	029959-000	VOLTAGE/HOUR METER	1

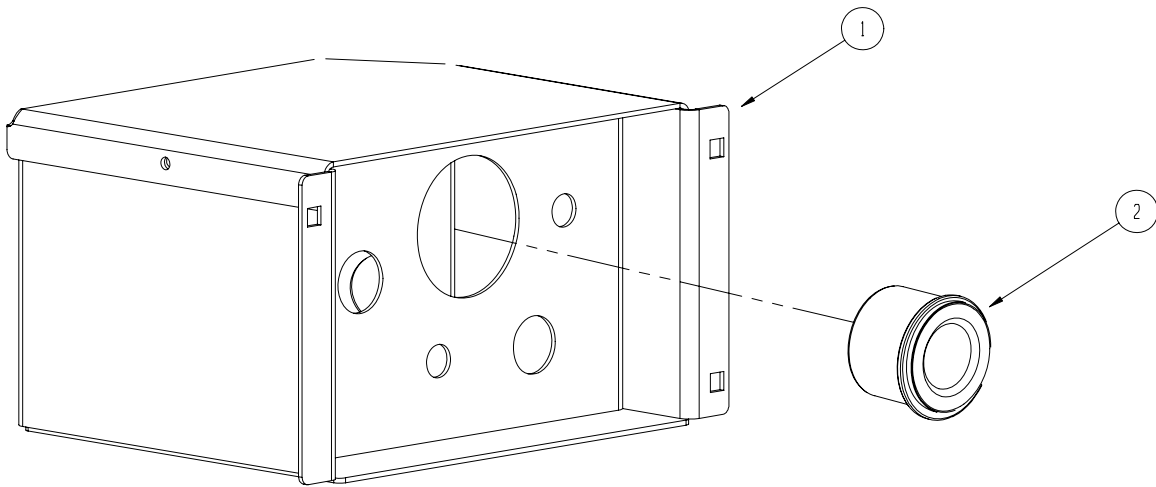
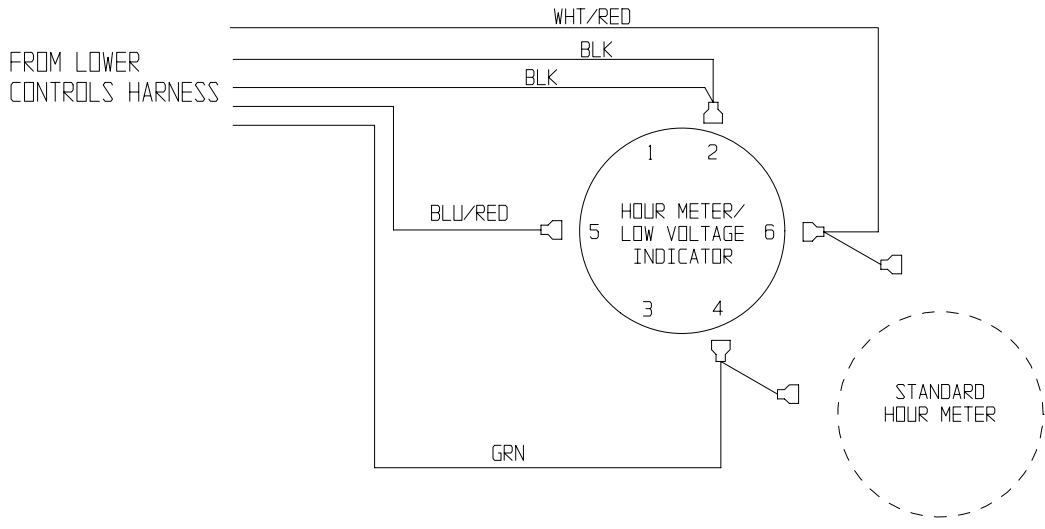

Lift Overload Option

107030-000 | Serial # M30176-M30338 |

ITEM	PART NO.	DESCRIPTION	QTY
1	063921-004	PRESSURE SWITCH	1
2	011923-003	FITTING - ADAPTOR (4FP-6MP)	1
3	014048-001	FITTING - COUPLING (6FP-6FJX)	1
4	020733-002	FITTING - TEE (6MJ-6MJ-6FJX)	1
5	011934-004	FITTING - 90° (6MB-6FJX)	1

ITEM	PART NO.	DESCRIPTION	QTY
6	029825-003	DIODE - 3A 400V	1
7	029601-011	CONNECTOR - RING (16-14GA) #6	2
8	029620-002	CONNECTOR - BUTT (16-14GA)	1
9	029452-099	WIRE - BLK 16GA	4
10	029931-003	CONN. FEMALE PUSH, 16-14GA X .250	2

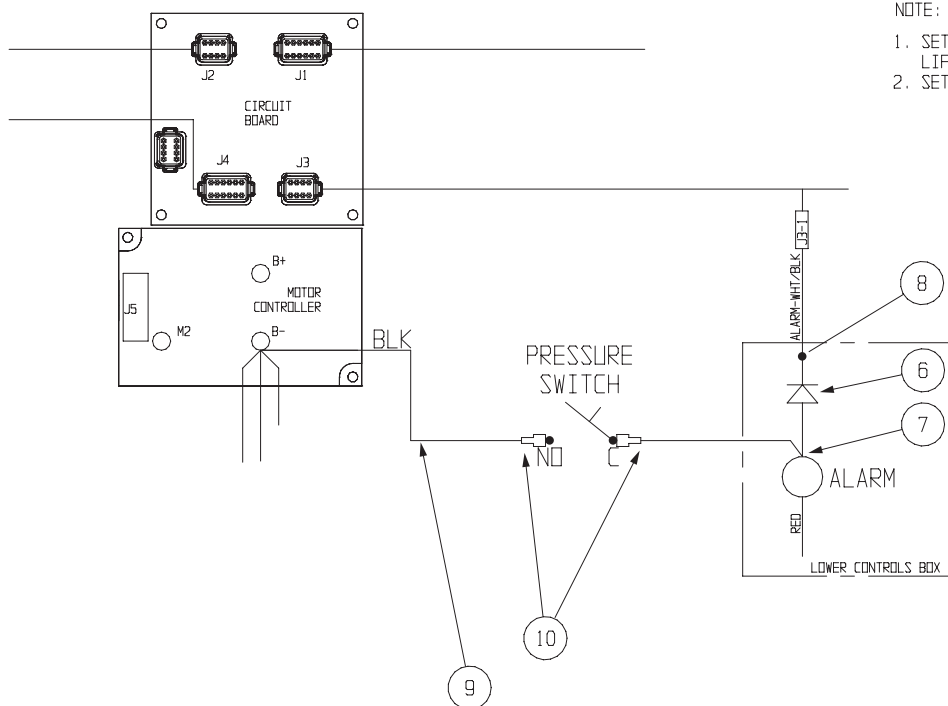

NOTE:

1. SET PRESSURE SWITCH TO SOUND ALARM WHEN LIFT-OFF AT RATED LOAD.
2. SET MAIN RELIEF TO LIFT RATED LOAD PLUS 100 LBS.

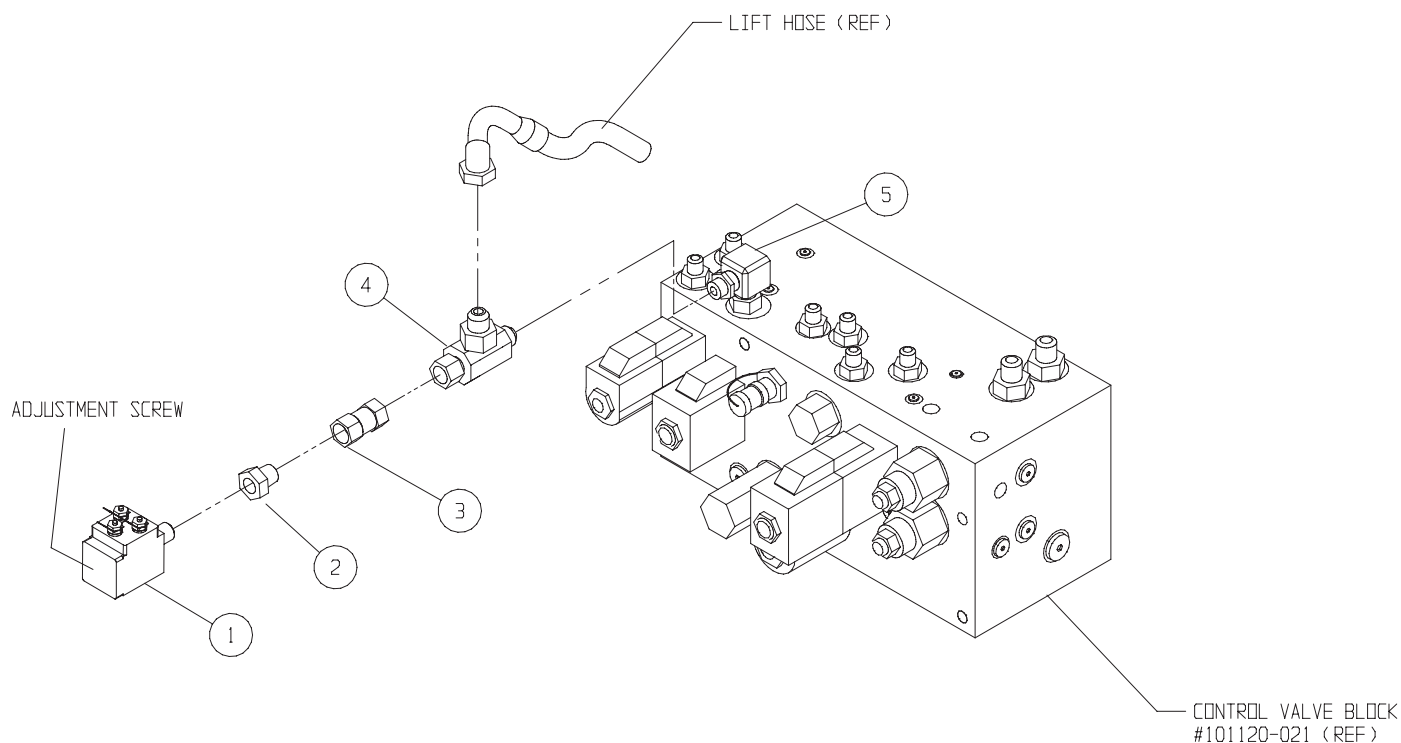

Horn Option

107031-000 | Serial # M30176-M30338 |

ITEM	PART NO.	DESCRIPTION	QTY
1	0.	CONTROLLER ASSY	REF
2	066805-018	SWITCH, PUSH BUTTON GE	1
3	066805-010	CONTACT BLOCK, NO	1
4	066807-003	HORN, 24 VDC	1
5	011252-006	SCREW HHC 1/4-20 X 3/4	1
6	011240-004	WASHER, 1/4 DIA STD FLAT	1

ITEM	PART NO.	DESCRIPTION	QTY
7	011238-004	WASHER, 1/4 SPLIT LOCK	1
8	029620-002	CONN BUTT 16-14	1
9	029601-011	CONN RING 16-14 GA #6	2
10	029601-014	CONN RING 16-14 GA 1/4"	1
11	029496-099	WIRE, 16 AWG 2 COND	6 FT
12	029453-099	WIRE, 16 AWG BLU	.5 FT

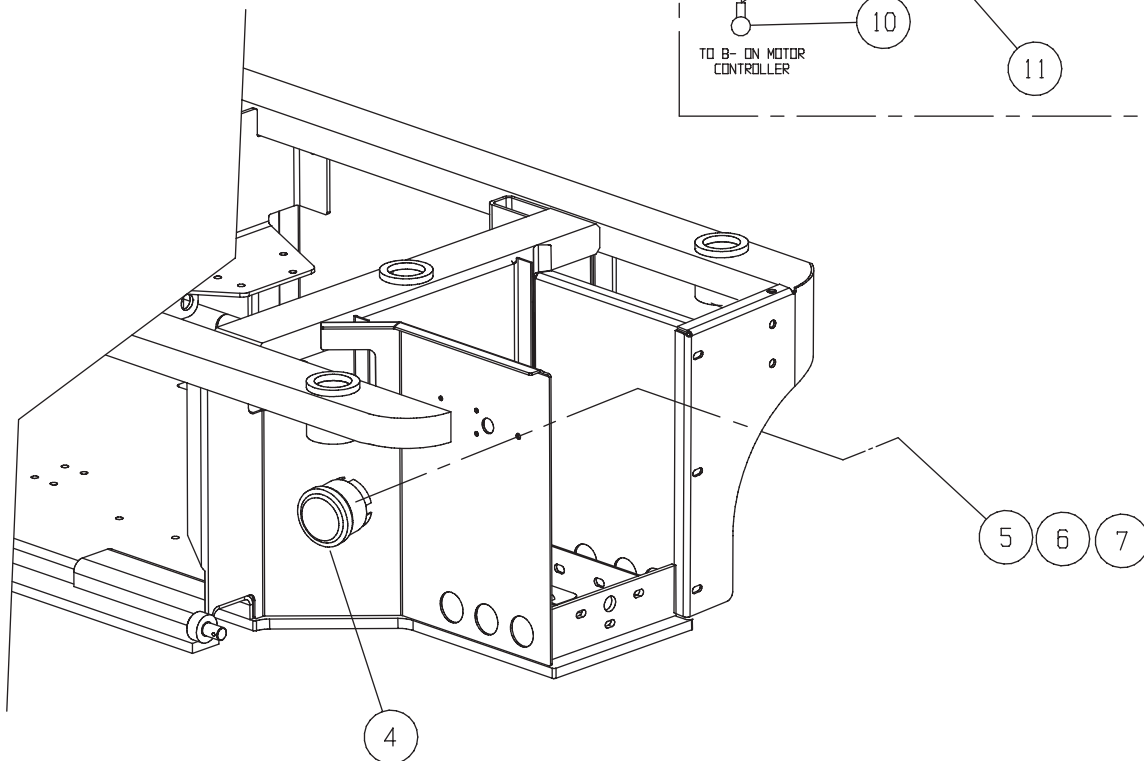
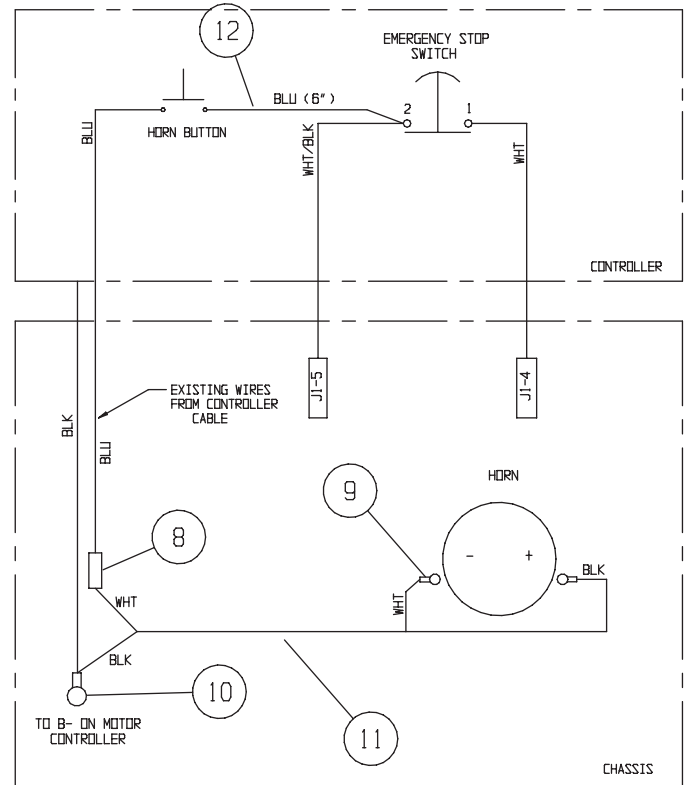
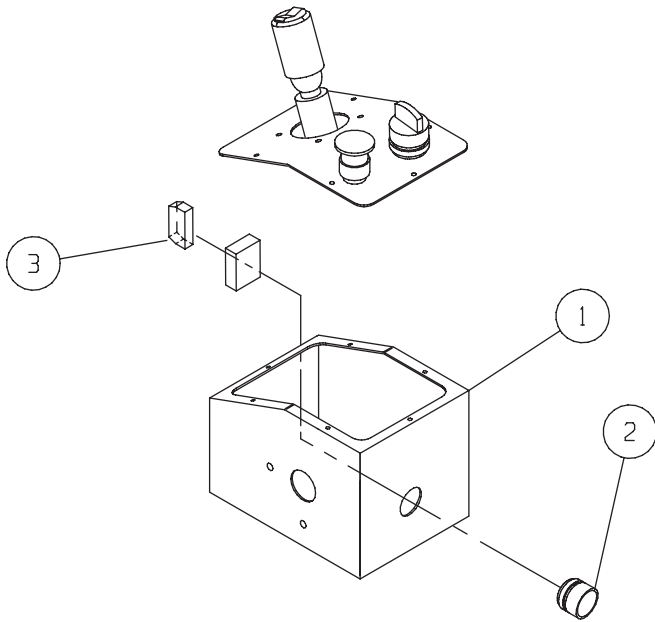

Hydraulic Schematic

107015-001 | Serial # M30176-M30338 |

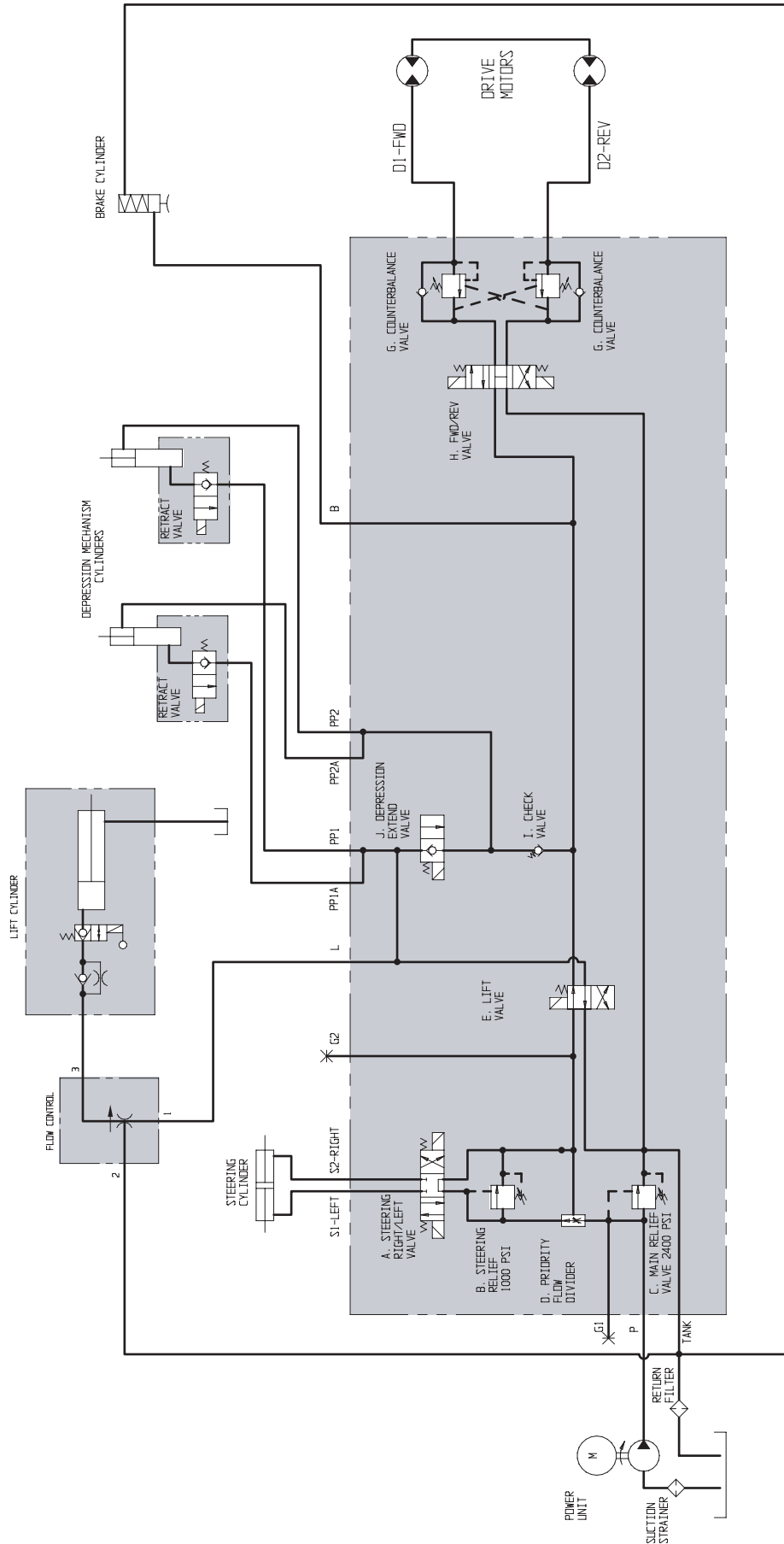

Electrical Schematic

107016-000 | Serial # M30176-M30338 |

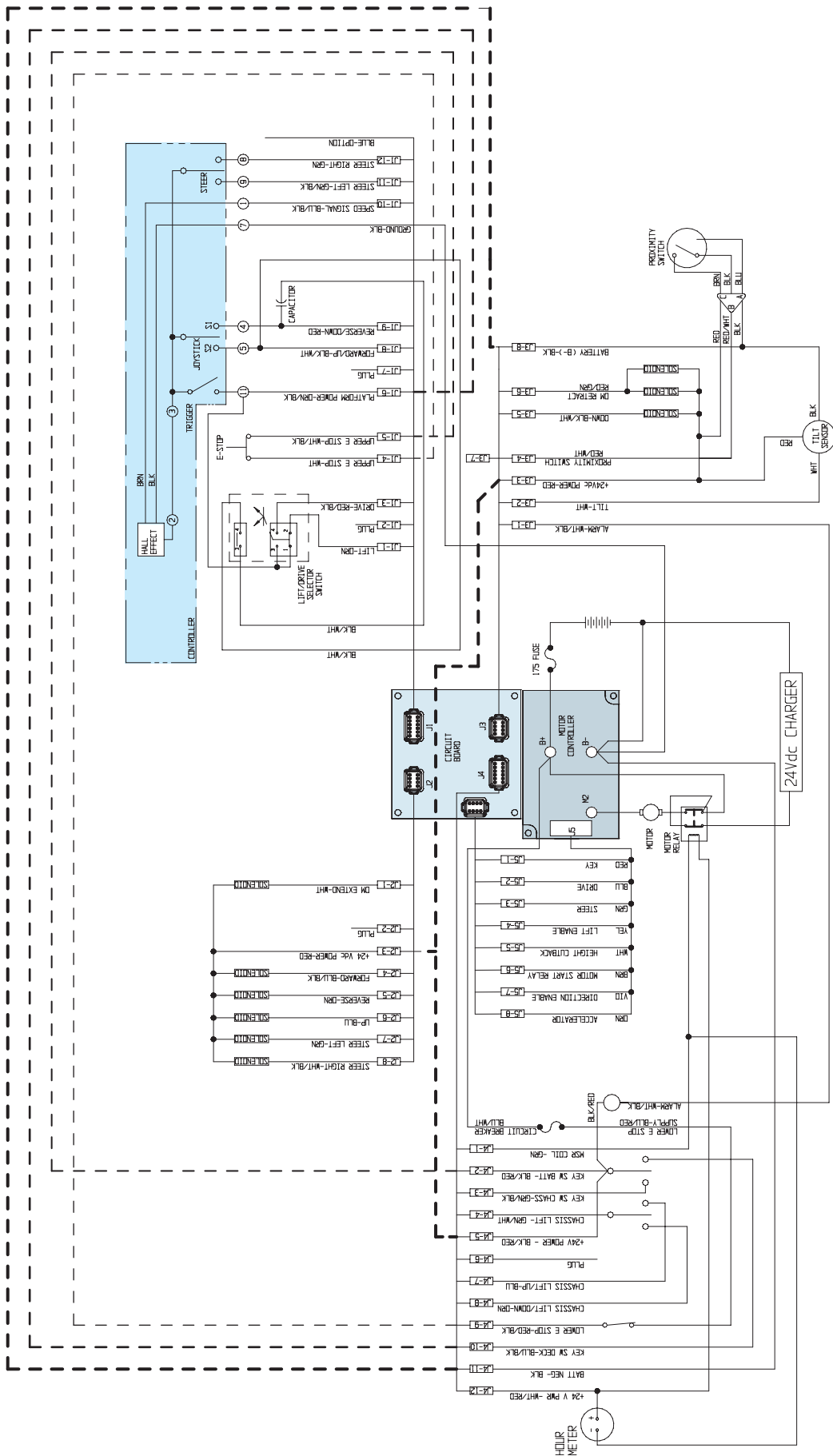

ITT Electrical Schematic

| Serial # M30339-M30642 |

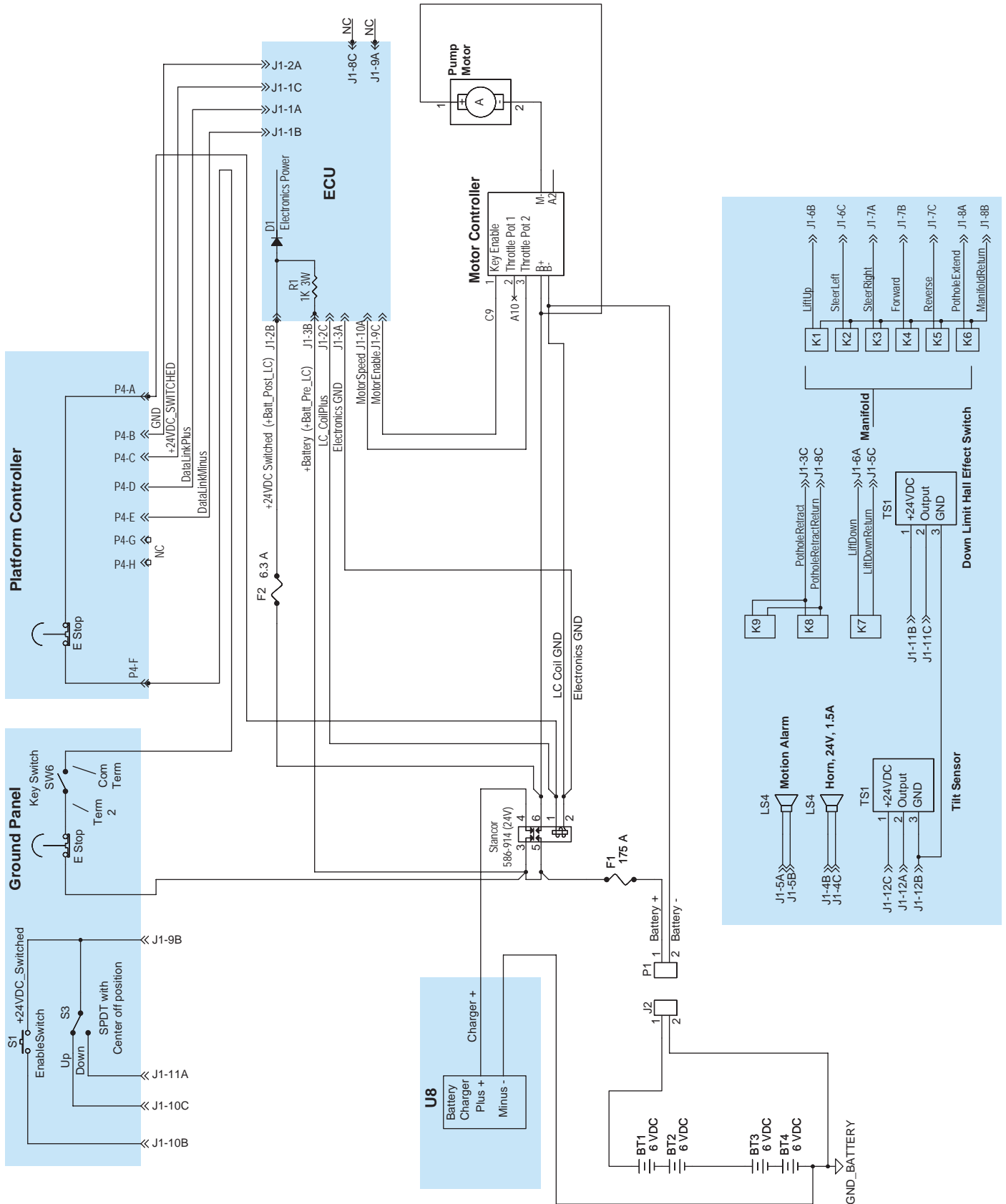

ITT Controller

| Serial # M30339-M30642 |

ITEM	PART NO.	DESCRIPTION	QTY	ITEM	PART NO.	DESCRIPTION	QTY
1	8860020201	BOOT RETAINER	1	27	251801	WIRE 22AWG RED	14.5"
2	501882-002	RUBBER BOOT	1	28	251809	WIRE 22AWG BLACK	14.5"
3	8490043720	SCREW - TAPTITE M4X12	4	29	251806	WIRE 22AWG VIOLET	12.5"
4	8791820025	GATE Y AXIS	1	30	251802	WIRE 22AWG ORANGE	12.5"
5	8791830024	TUBE UNIVERSAL JOINT	1	32	8761320034	CABLE CLAMP (STRAIN RELIEF)	1
6	220369	MAGNET RING	1	33	220737	WARRANTY SEAL	2
7	8860030042	SPRING TORSION 6N	4	34	100768	LABEL	1
8	8860020203	SPRING STOP CAP	2	35	100788	LUBRICANT	A/R
9	8860020202	SPRING STOP	2	36	501882-001	JOYSTICK ROCKER BOOT	1
10	8890020306	HOUSING UNIVERSALJOINT	1	37	220762	SWITCH ACTUATOR	1
11	8490043723	SCREW - TAPPING K30X8	2	38	8490024001	BOOT K12 1X1 BLK	1
12	8890020305	HOUSING	1	39	8890020220	SPRING	1
13	8490043013	BUSHING PIVOT PIN	4	40	220763	LEVER	1
14	8490043717	PIVOT PIN	4	41	220769	SPRING CAP	1
15	251884	PCB ASSY - SENSOR COATED	1	42	112094	SCREW PLASTITE, PH, TORX, #4	7
16	220906	SENSOR CONNECTED WIRE ASSY	1	43	220761	HANDLE HALF - RIGHT	1
17	112088	SCREW - TAPTITE #3=48X9/16"	4	44	220760	HANDLE HALF - LEFT	1
18	8890020303 A	HOUSING BOTTOM	1	45	8890020207	TUBE STRAP	1
19	8490043721	SCREW - TAPTITE M4X16	4	46	8445004700	K12CF 1.3 9N.5 (BMW)	2
20	8490043831	SCREW - TAPPING K30X12	2	47	8890020221	PCB 2XK12 S2J3	1
21	251283	HEAT SHRINK	1.75"	48	8461101003	ESM MODULE	1
23	250867	CONTACT AMP	5	49	100544	RTV #3145	A/R
26	251805	WIRE 22AWG BLUE	14.5"	50	100765	LOCTITE PRISM	A/R
				51	220803	WIRE ASSEMBLY (GROUND)	1

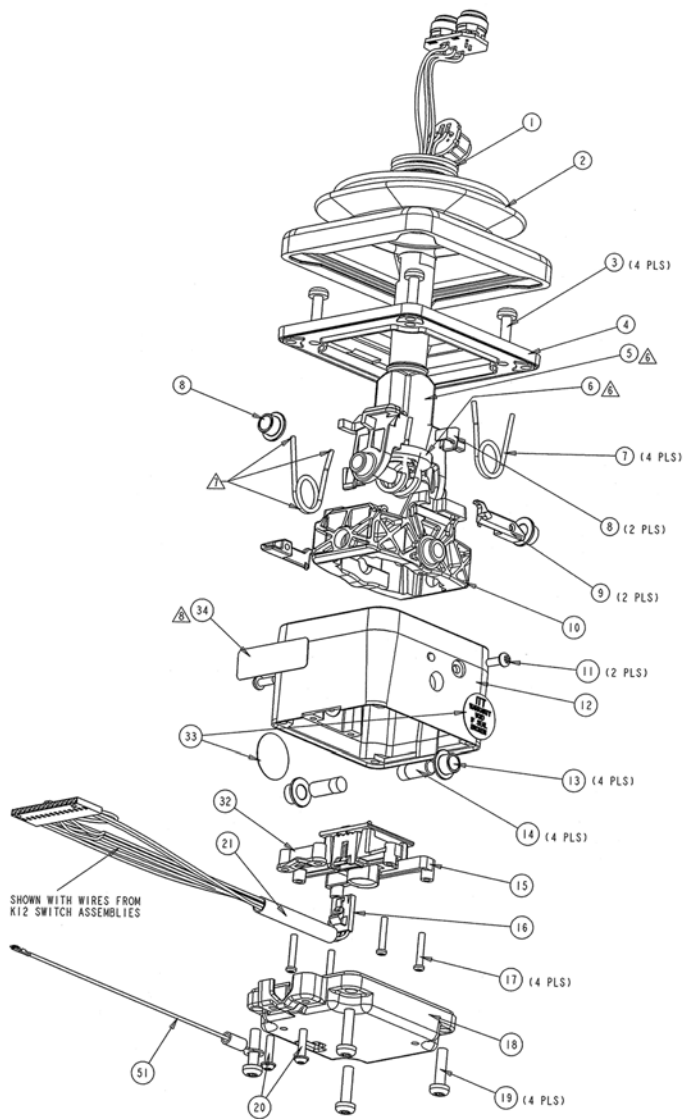

SHOWN WITH WIRES FROM
K12 SWITCH ASSEMBLIES

NOTES:

- TORQUE VALUES:
 ITEM 3, 21.2 IN-LBS
 ITEM 11, 4.5 IN-LBS
 ITEM 17, 3.5 IN-LBS
 ITEM 19, 21.2 IN-LBS
 ITEM 20, 4.5 IN-LBS
 ITEM 42, 8.0 IN-LBS

▲ SONIC STAKE MAGNET RING, (ITEM 6), TO TUBE, (ITEM 5).
 AFTERSWARDS, IF SHAFT KEY IS NOT PRESENT, APPLY A SMALL
 AMOUNT OF LOCTITE, (ITEM 50), TO JOINT BETWEEN MAGNET
 RING AND TUBE.

▲ NYE GREASE (ITEM 35) TO BE APPLIED IN THIS AREA
 FOR ALL TORSION SPRINGS (ITEM 7).

▲ PRINT LABEL, ITEM 34, WITH THE FOLLOWING:
 P/N 604064
 DATE: YYWW
 S/N XXXXXXXX

▲ APPLY RTV, ITEM 49, TO BOTTOM OF PC BOARDS AFTER
 SOLDERING WIRES.

[*] 10) CALIBRATE PER ITT SPECIFICATION A15708.

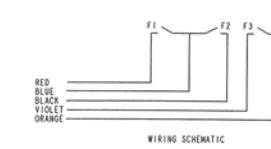
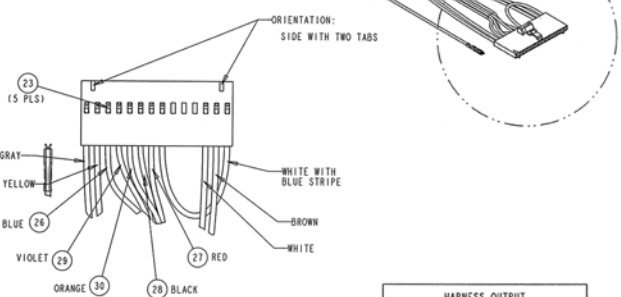
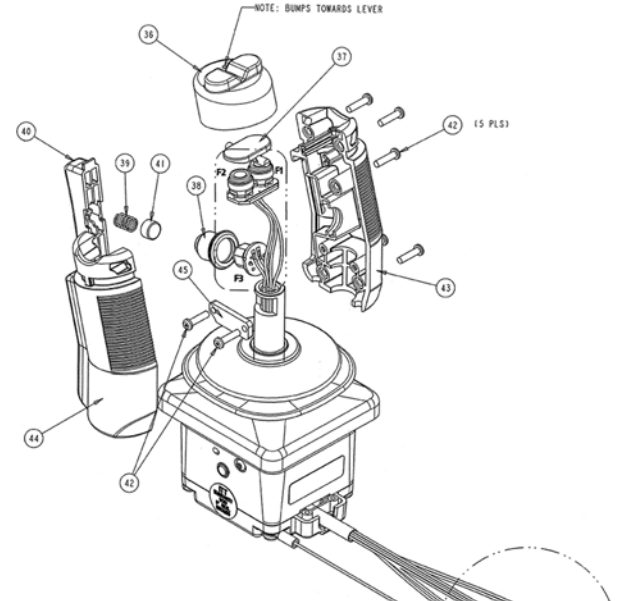
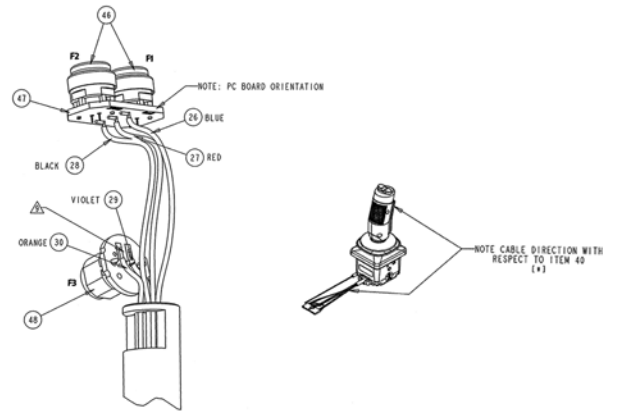

HARNESS OUTPUT	
COLOR	SIGNAL
GRAY	SENSOR 1 OUTPUT
YELLOW	SENSOR 2 OUTPUT
BLUE	GROUND
VIOLET	GROUND
ORANGE	DRIVE ENABLE SWITCH
BLACK	LEFT TURN SWITCH
RED	RIGHT TURN SWITCH
WHITE	+24 VDC
WHT/BLU	JOYSTICK DETECTION
BROWN	GROUND

ITT Controller Assembly

| Serial # M30339-M30642 |

1	601064	JOYSTICK	1
*		JOYSTICK RUBBER BOOT	1
*		JOYSTICK STEERING BOOT	1
2	251428	OVERLAY	1
3	220964	MOUNTING PLATE	1

4	220494	SEAL	1
5	251456	PRINTED CIRCUIT BOARD	1
6	220488	UPPER CONTROL BOX (BOX ONLY)	1
7	220695	EMERGENCY STOP BUTTON ASSEMBLY	1

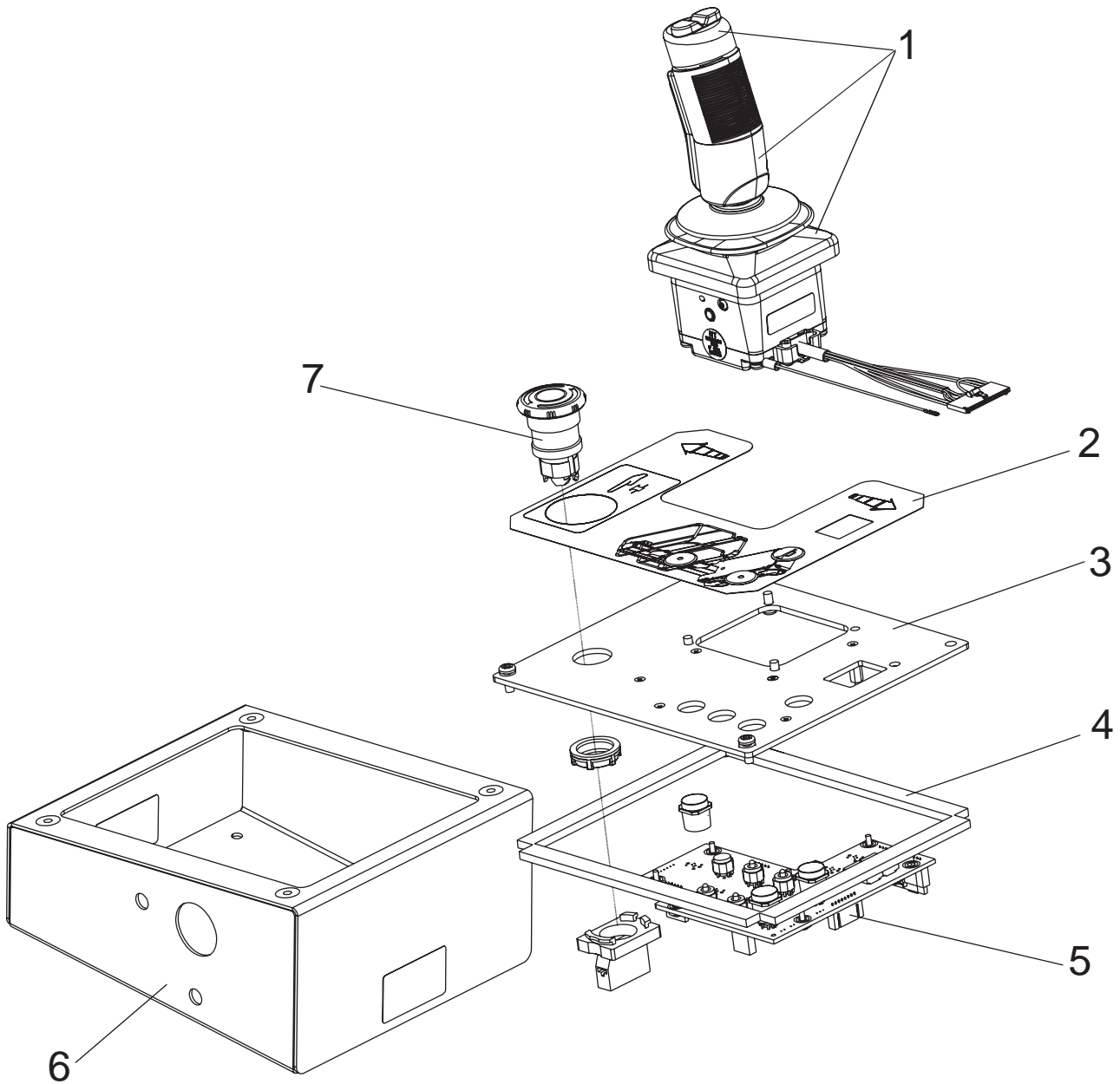

ECU

| Serial # M30339-M30642 |

ITEM	PART	DESCRIPTION	QTY
1	221101	EXTRUSION ALUMINUM	1
2	220966	END PLATE, ECU	1
3	220606	END PLATE, ECU	1
4	251898	ASM, PCB ECU, COATED	1
5	100728	LUBRICANT, NYOGEL 760G	A/R
6	220562	SCREW, #6-32, HEX WASHER HEAD	8
7	220737	ITT WARRANTY SEAL	2
8	220718	LABEL	1

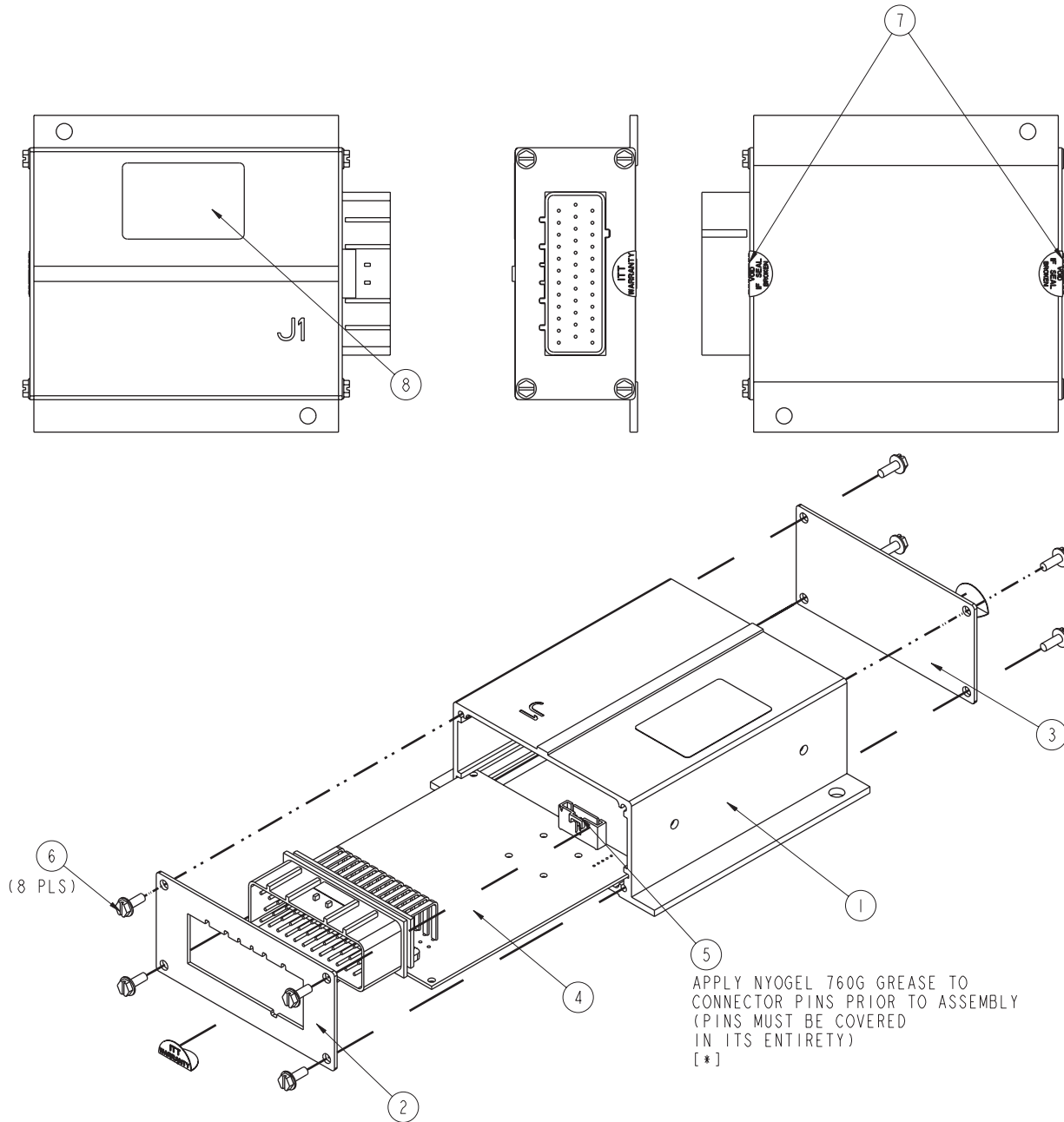

NOTES:

[*] DENOTES CRITICAL PARAMETERS.

[@] DENOTES CONTROL PARAMETERS.

TORQUE VALUES:

ITEM 6: 12 IN-LBS

ITT Control Cable Assembly

| Serial # M30339-M30642 |

ITEM	PART	DESCRIPTION	QTY	ITEM	PART	DESCRIPTION	QTY
1	310014	ASSY, PLATFORM CONTROLLER TM12	1	14	220963	HORN, 335hZ, 24VDC	1
2	310031	ASSY, MOTOR CONTROLLER ALARM COMPARTMENT	1	28	220696	CONTACT BLOCK, N.C.	1
3	310011	ASSY, ECU	1	29	220109	SWITCH LOCK	1
4	230041	CABLE ASSEMBLY HARNESS J1	1	30	230119	CABLE ASSY	1
5	230025	CABLE ASSY, BATTERY TO HARNESS (SHORT)	3	31	230140	CABLE ASSY, LC TO MC B=	1
6	230040	CABLE ASSY, BATTERY DISCONNECT TO POS/NEG	1	32	230050	CABLE ASSY, MOTOR TO MOTOR CONTROLLER	1
7	230139	CABLE ASSY, BATT DISCON TO FUSE/TO NTA CTRL B-	1	33	230088	CONTACTOR	1
8	230125	CABLE ASSY, PUMP + TO LC 6	1	34	250269	FUSE BLOCK	1
11	220491	SWITCH, PUSH BUTTON	1	35	250264	FUSE, 175 AMP	1
12	220490	SWITCH, TOGGLE	1	36	220992	WIRE ASSY, LC3 TO LC5	1
13	220695	E-STOP SWITCH	1	37	230028	CABLE ASSY LC TO FUSE	1

REFER TO SHEET ONE FOR APPLICABLE NOTES

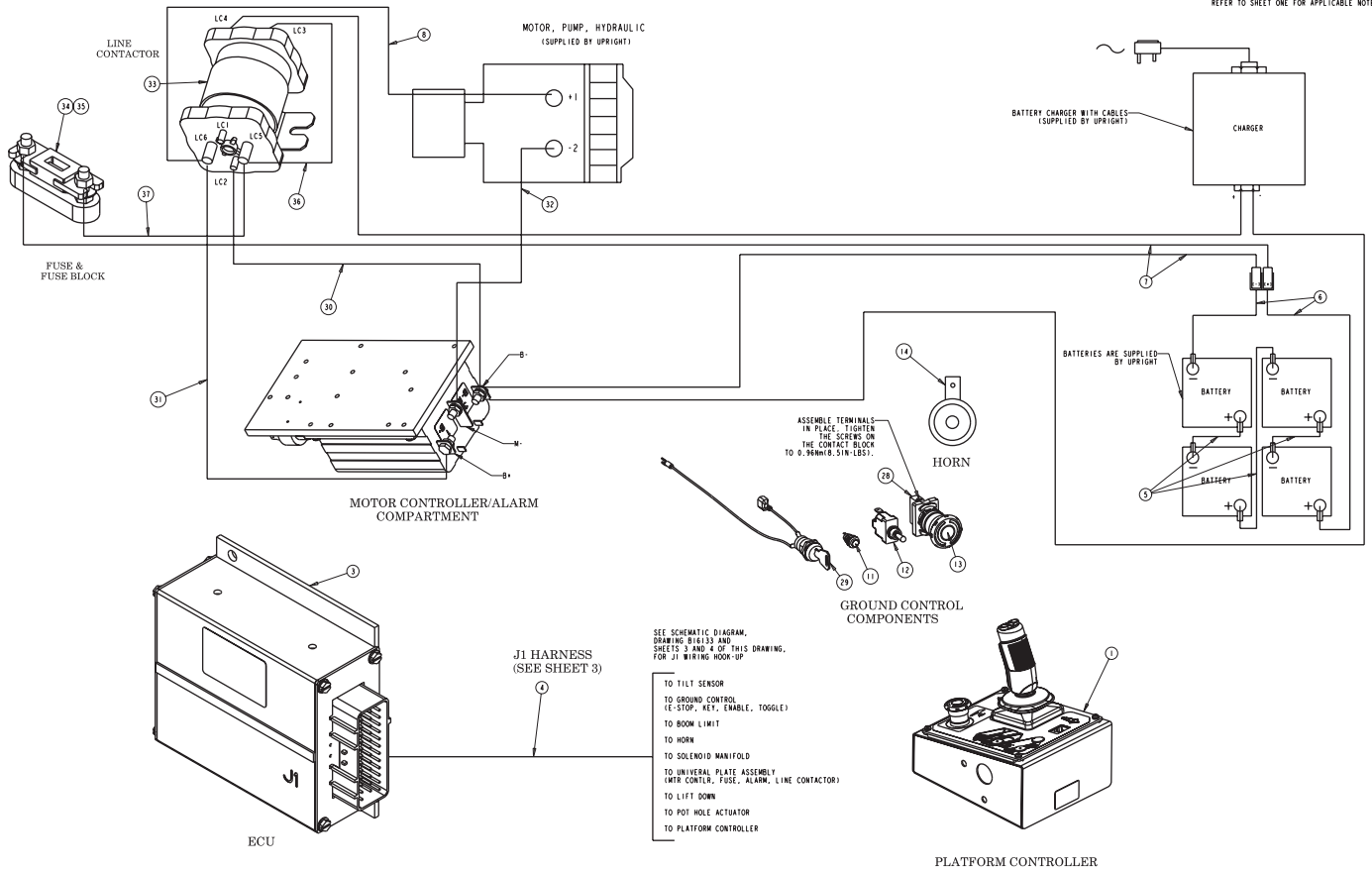

J1 TERMINATION POINTS					
ITEM	COLOR	DESCRIPTION	ITEM	COLOR	DESCRIPTION
1	N/A	TO PLATFORM CONTROLLER (SEE SHEET 4)	13	BLACK	TO ALARM (-)
2a	GREY	TO POT HOLE CYLINDER (RETURN)	14	RED	TO MOTOR CONTROLLER, TERMINAL 3
2b	GREY	TO POT HOLE CYLINDER (RETURN)	15	BLACK	TO MOTOR CONTROLLER, TERMINAL 1
3a	PINK	TO POT HOLE CYLINDER (RETRACT)	16	WHITE/BLUE	TO VALVE, STEER, LEFT (INBOARD, MANIFOLD RETURN)
3b	PINK	TO POT HOLE CYLINDER (RETRACT)	17a	BLACK	TO VALVE, STEER, LEFT (INBOARD, MANIFOLD RETURN)
4	GREY	TO LIFT DOWN (RETURN)	17b	BLACK	TO VALVE, STEER, RIGHT (OUTBOARD, MANIFOLD RETURN)
5	PINK	TO LIFT DOWN	17c	BLACK	TO VALVE, LIFT (MANIFOLD RETURN)
6	YELLOW	TO LINE CONTACTOR, LC3	17d	BLACK	TO VALVE, POT HOLE EXTEND (MANIFOLD RETURN)
7	RED (WITH FUSE)	TO LINE CONTACTOR, LC6	17e	BLACK	TO VALVE, FORWARD (INBOARD, MANIFOLD RETURN)
8	BLUE	TO LINE CONTACTOR, LC3	17f	BLACK	TO VALVE, REVERSE (OUTBOARD, MANIFOLD RETURN)
9	WHITE	TO LINE CONTACTOR, LC1	18	WHITE/BLACK	TO VALVE, STEER, RIGHT (OUTBOARD, MANIFOLD RETURN)
10	BLACK	TO LINE CONTACTOR, LC2	19	LIGHT BLUE	TO VALVE, LIFT
11	PINK	TO LINE CONTACTOR, LC1	20	WHITE	TO VALVE, POT HOLE EXTEND
12	ORANGE	TO ALARM (+)	21	BLUE/BLACK	TO VALVE, FORWARD (INBOARD)
			22	ORANGE	TO VALVE, REVERSE (OUTBOARD)
			23	GREY	TO HORN (-)
			24	PINK	TO HORN (+)
			25	N/A	TO BOOM LIMIT
			26a	RED	TO TOGGLE, COM
			26b	RED	TO ENABLE SWITCH (1)
			27	BLACK/ORANGE	TO TOGGLE, DOWN
			28	BLUE/PURPLE	TO TOGGLE, UP
			29	BLUE	TO ENABLE SWITCH (2)
			30	BLUE	TO KEYSWITCH, FACTOR MILE
			31	YELLOW	TO E-STOP 1
			32	N/A	TO TILT SENSOR

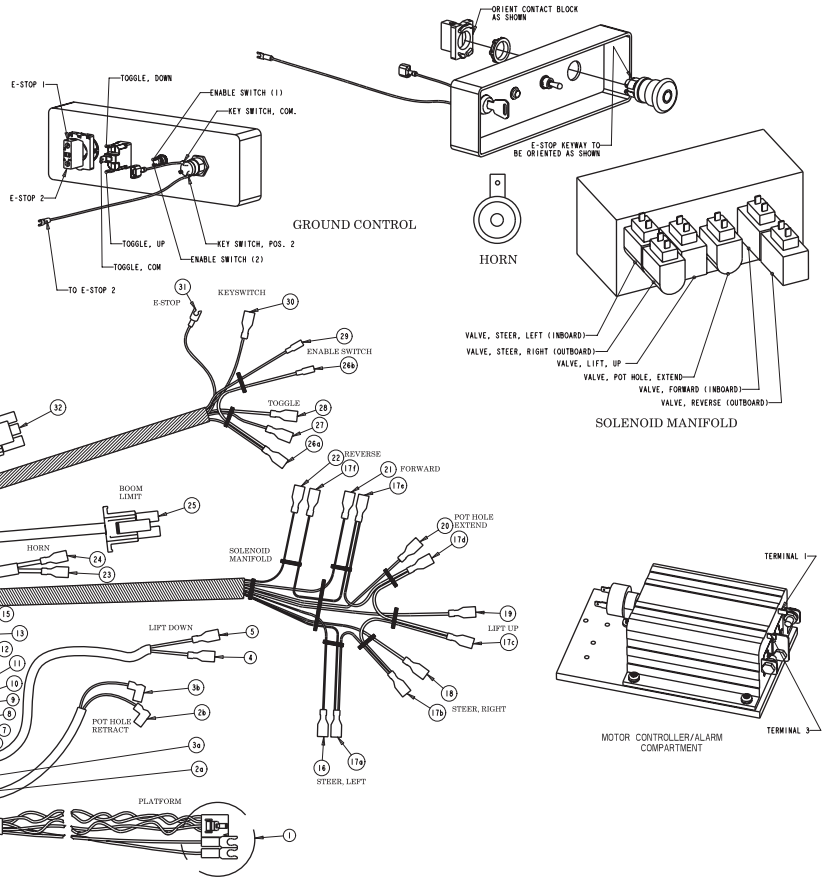

ITT Universal Compartment

| Serial # M30339-M30642 |

ITEM	PART NO.	DESCRIPTION	QTY
1	221100	MOUNTING PLATE	1
2	230057	MOTOR CONTROLLER	1
3	502489-000	CONTACTOR	1
4	501877-000	FUSE BLOCK	1
5	502494-000	FUSE 175 AMP	1
6	220493	ALARM, FOOTMOUNT	1
7	112099	SCREW, PH, M6X10MM LONG, X-RECESS	2
8	251910	LOCKWASHER, SPLIT, M6	6
9	112096	SCREW, FH, M6X20MM LONG, X-RECESS	2
10	112106	SCREW, PH, M3X6MM LONG, X-RECESS	2

ITEM	PART NO.	DESCRIPTION	QTY
11	230028	CABLE ASSY, LC TO FUSE/LC TO MC B+	2
12	220992	WIRE ASSY, LC3 TO LC5	1
13	220492	WIRE ASSY, LC2 TO MOTOR CONTROL B-	1
14	112153	BOLT, M8X16MM LONG	3
15	112062	LOCKWASHER, SPLIT, M8	3
16	112150	NUT, M8	3
17	100768	LABEL	3
18	100805	LABEL	4
19	112119	SCREW, PH, 6MX12MM LONG, X-RECESS	4

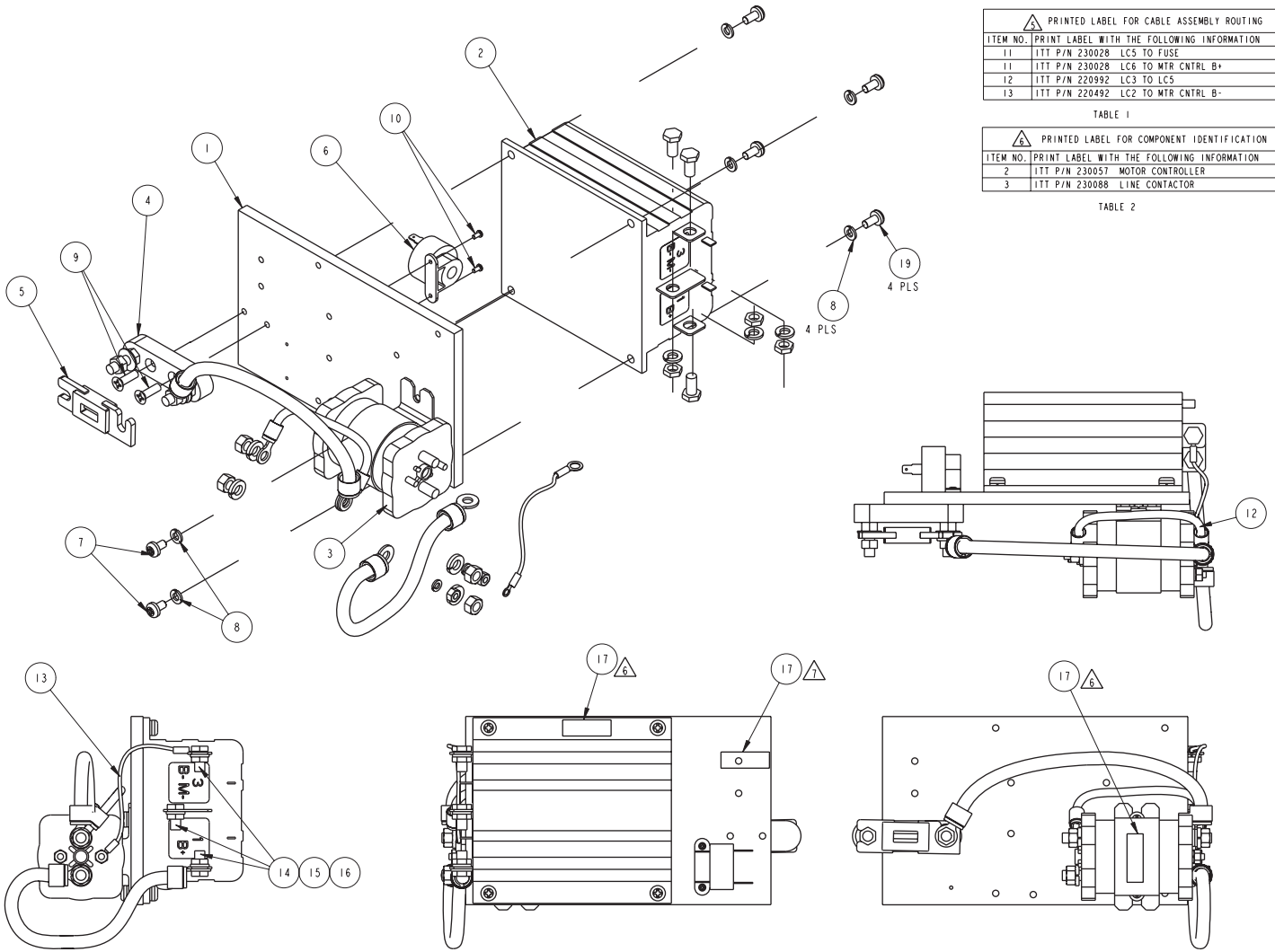

⚠️ PRINTED LABEL FOR CABLE ASSEMBLY ROUTING

ITEM NO.	PRINT LABEL WITH THE FOLLOWING INFORMATION
11	ITT P/N 230028 LC5 TO FUSE
11	ITT P/N 230028 LC6 TO MTR CNTRL B+
12	ITT P/N 220992 LC3 TO LC5
13	ITT P/N 220492 LC2 TO MTR CNTRL B-

TABLE 1

⚠️ PRINTED LABEL FOR COMPONENT IDENTIFICATION

ITEM NO.	PRINT LABEL WITH THE FOLLOWING INFORMATION
2	ITT P/N 230057 MOTOR CONTROLLER
3	ITT P/N 230088 LINE CONTACTOR

TABLE 2

NOTES:
 [★] DENOTES CRITICAL PARAMETERS.
 [⊙] DENOTES CONTROL PARAMETERS.

⚠️ PRINT LABEL (STOCK NO. 100805) WITH THE INFORMATION AS SHOWN IN TABLE 1. ATTACH LABEL TO APPROPRIATE CABLE ON END NEAR TERMINATION.

⚠️ PRINT LABEL (STOCK NO. 100768) WITH THE INFORMATION AS SHOWN IN TABLE 2. PLACE LABELS IN APPROXIMATE AREA AS SHOWN.

⚠️ PRINT LABEL (STOCK NO. 100768) WITH THE FOLLOWING INFORMATION AND PLACE IN APPROXIMATE AREA SHOWN.
 ITT ASSEMBLY NUMBER 310012

TORQUE VALUES:
 ITEM 7, 2.26Nm [20 IN-LBS]
 ITEM 9, 2.26Nm [20 IN-LBS]
 ITEM 10, .79Nm [7 IN-LBS]
 ITEM 19, 2.26Nm [20 IN-LBS]
 ITEM 16, HAND TIGHTEN (SNUG)
 CONTACTOR NUTS, HAND TIGHTEN (SNUG)

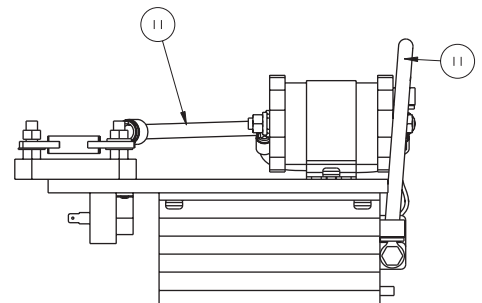

UpRight

Call Toll Free in U.S.A.
1-866-843-3350

UpRight USA

2686 S. Maple Avenue
Fresno, California 93725

TEL:(559) 443-6600

FAX:(559) 268-1756

PARTS:1-866-843-3381

EMAIL:info@uidistribution.com

www.uidistribution.com

UpRight

Call Toll Free in U.S.A.

1-866-843-3350